

PXI-6683 Series

Timing and Synchronization Module

This manual describes the electrical and mechanical aspects of the PXI-6683 and PXI-6683H, and contains information concerning their operation and programming.

Conventions



Caution This icon denotes a caution, which advises you of precautions to take to avoid injury, data loss, or a system crash. When this symbol is marked on the product, refer to the *Safety Information* section of the *Introduction* for precautions to take.

National Instruments Documentation

The PXI-6683 Series User Manual is one piece of the documentation set for your measurement system. You could have any of several other documents describing your hardware and software. Use the documentation you have as follows:

- Measurement hardware documentation—This documentation contains detailed information about the measurement hardware that plugs into or is connected to the computer. Use this documentation for hardware installation and configuration instructions, specifications about the measurement hardware, and application hints.
- Software documentation—Refer to the NI-Sync Help, available at ni.com/manuals.

You can download NI documentation from ni.com/manuals.

Related Documentation

The following documents contain information that you might find helpful as you read this manual.

- *PICMG 2.0 R3.0, CompactPCI Core Specification*, available from PICMG at www.picmg.org.
- *PXI Specification, Revision 2.1*, available from www.pxisa.org.
- *NI-VISA User Manual*, available from ni.com/manuals.
- *NI-VISA Help*, included with the NI-VISA software.
- *NI-Sync User Manual*, available from ni.com/manuals.

Contents

Introduction.....	2
What You Need to Get Started.....	2
Unpacking.....	3
Safety Information.....	3
Installing and Configuring.....	5
Installing the Software.....	5
Installing the Hardware.....	5
Configuring the Module.....	6
Hardware Overview.....	7
PXI-6683 Front Panel and LEDs.....	9
Connectors.....	11
Hardware Features.....	11
Clock and Event Generation.....	13
Routing Signals.....	14
I/O Considerations.....	16
Synchronization.....	23
GPS.....	24
IRIG-B.....	24
802.1AS.....	25
IEEE 1588.....	25
Pulse Per Second (PPS).....	25
Synchronization Best Practices.....	26
Calibration.....	28
Factory Calibration.....	28

Introduction

The PXI-6683 and PXI-6683H timing and synchronization modules synchronize PXI and PXI Express systems using GPS, IEEE 1588, IEEE 802.1AS, IRIG-B, or PPS.

The PXI-6683 has a full PXI connector for full PXI timing slot functionality. The PXI-6683H is designed to allow installation in a hybrid slot in a PXI Express system; some PXI timing slot features are not available using a PXI-6683H board.

What You Need to Get Started

To set up and use a PXI-6683 Series timing and synchronization module, you need the following items:

- PXI-6683 Series timing and synchronization module
- PXI-6683 Series User Manual
- NI-Sync driver software
- One of the following software packages and documentation:
 - LabVIEW
 - LabWindows™/CVI™
 - Microsoft Visual C++ (MSVC)

- PXI or PXI Express chassis with an appropriate slot (full PXI slot for the PXI-6683 and PXI-6683H, PXIe hybrid slot for the PXI-6683H)
- PXI or PXI Express embedded controller, or a desktop computer connected to the PXI or PXI Express chassis using MXI hardware

Unpacking

The PXI-6683 Series is shipped in an antistatic package to prevent electrostatic damage to the module. Electrostatic discharge (ESD) can damage several components on the module.



Caution Never touch the exposed pins of connectors.

To avoid such damage in handling the module, take the following precautions:

- Ground yourself using a grounding strap or by touching a grounded object.
- Touch the antistatic package to a metal part of the computer chassis before removing the module from the package.

Remove the module from the package and inspect the module for loose components or any sign of damage. Notify NI if the module appears damaged in any way. Do not install a damaged module into the computer.

Store the PXI-6683 Series board in the antistatic envelope when not in use.

Safety Information

The following section contains important safety information that you must follow when installing and using the PXI-6683 Series.

Do not operate the product in a manner not specified in this document. Misuse of the product can result in a hazard. You can compromise the safety protection built into the product if the product is damaged in any way. If the product is damaged, return it to National Instruments for repair.

Do not substitute parts or modify the product except as described in this document. Use the product only with the chassis, modules, accessories, and cables specified in the installation instructions. You must have all covers and filler panels installed during operation of the product.

Do not operate the product in an explosive atmosphere or where there may be flammable gases or fumes. If you must operate the product in such an environment, it must be in a suitable rated enclosure.

If you need to clean the product, use a soft, nonmetallic brush. The product must be completely dry and free from contaminants before you return it to service.

Operate the product only at or below Pollution Degree 2. Pollution is foreign matter in a solid, liquid, or gaseous state that can reduce dielectric strength or surface resistivity. The following is a description of pollution degrees:

- Pollution Degree 1 means no pollution or only dry, nonconductive pollution occurs. The pollution has no influence.
- Pollution Degree 2 means that only nonconductive pollution occurs in most cases. Occasionally, however, a temporary conductivity caused by condensation must be expected.
- Pollution Degree 3 means that conductive pollution occurs, or dry, nonconductive pollution occurs that becomes conductive due to condensation.

You must insulate signal connections for the maximum voltage for which the product is rated. Do not exceed the maximum ratings for the product. Do not install wiring while the product is live with electrical signals. Do not remove or add connector blocks when power is connected to the system. Avoid contact between your body and the connector block signal when hot swapping modules. Remove power from signal lines before connecting them or disconnecting them from the product.

Operate the product at or below the measurement category¹ marked on the hardware label. Measurement circuits are subjected to working voltages² and transient stresses (overvoltage) from the circuit to which they are connected during measurement or test. Measurement categories establish standard impulse to withstand voltage levels that commonly occur in electrical distribution systems. The following is a description of measurement categories:

- Measurement Category I is for measurements performed on circuits not directly connected to the electrical distribution system referred to as MAINS³ voltage. This category is for measurements of voltages from specially protected secondary circuits. Such voltage measurements include signal levels, special hardware, limited-energy parts of hardware, circuits powered by regulated low-voltage sources, and electronics.
- Measurement Category II is for measurements performed on circuits directly connected to the electrical distribution system (MAINS³). This category refers to local-level electrical distribution, such as that provided by a standard wall outlet (for example, 115 AC voltage for U.S. or 230 AC voltage for Europe). Examples of Measurement Category II are measurements performed on household appliances, portable tools, and similar hardware.
- Measurement Category III is for measurement performed in the building installation at the distribution level. This category refers to measurements on hard-wired hardware such as hardware in fixed installations, distribution boards, and circuit breakers. Other examples are wiring, including cables, bus bars, junction boxes, switches, socket outlets

¹ Measurement categories, also referred to as overvoltage or installation categories, are defined in electrical safety standard IEC 61010-1 and IEC 60664-1.

² Working voltage is the highest rms value of an AC or DC voltage that can occur across any particular insulation.

³ MAINS is defined as a hazardous live electrical supply system that powers hardware. Suitably rated measuring circuits may be connected to the MAINS for measuring purposes.

in the fixed installation, and stationary motors with permanent connections to fixed installations.

- Measurement Category IV is for measurements performed at the primary electrical supply installation typically outside buildings. Examples include electricity meters and measurements on primary overcurrent protection devices and on ripple control units.

Installing and Configuring

This section describes how to install the PXI-6683 Series hardware and software and how to configure the device.

Installing the Software

Refer to the `readme.htm` file that accompanies the NI-Sync software for software installation directions.



Note Be sure to install the driver software before installing the PXI-6683 Series hardware.

Installing the Hardware

The following are general installation instructions. Consult the chassis user manual or technical reference manual for specific instructions and warnings about installing new modules.



1. Power off and unplug the chassis.



Caution Do not install the PXI-6683 Series in the system controller slot (Slot 1) of a chassis.

2. Choose an available slot in the chassis. Refer to [Table 1](#) on page 6 for more information about functionality.
 - PXI-6683—Install in an available PXI slot. PXI triggers are accessible from any PXI slot, but the PXI-6683 can replace PXI_CLK10 and control PXI_STAR triggers only if it is installed in the system timing slot of a PXI chassis.
 - PXI-6683H—Install in an available PXI slot. If you are using a PXI Express (PXIe) system, install the PXI-6683H in an available PXI or PXIe/hybrid slot. Unlike the PXI-6683, the PXI-6683H cannot replace PXI_CLK10 or drive PXI_STAR triggers.

Table 1. PXI/PXI Express Slot Type Compatibility

NI PXI Board	PXI System Timing Slot 	PXI Peripheral Slot 	PXI Express Hybrid Slot 
PXI-6683	X*	X†	—
PXI-6683H	X†	X†	X†

*Compatible: PXI_CLK10, PXI_CLKIN, PXI_STAR, PXI_TRIG functionality available.
†Compatible: PXI_TRIG functionality available

- Remove the filler panel for the PXI or PXI Express hybrid slot you chose in step 2.
- Ground yourself using a grounding strap or by touching a grounded object. Follow the ESD protection precautions described in the [Unpacking](#) section.
- Remove any packing material from the front panel screws and backplane connectors.
- Insert the PXI-6683 Series module into the PXI or PXI Express hybrid slot. Use the injector/ejector handle to fully insert the module into the chassis.
- Screw the front panel of the module to the front panel mounting rail of the chassis.
- If adjacent slots are not populated, use EMC filler panels to cover the opening.



Caution To ensure the specified EMC performance, you must install PXI EMC filler panels (National Instruments part number 778700-01) in all open chassis slots.

- Visually verify the installation.
- Plug in and power the chassis.

The PXI-6683 Series is now installed.

Verifying the Installation

During the first boot following the software and hardware installation of the PXI-6683 Series module, the OS detects the device and associates it with the NI-Sync driver.

Configuring the Module

The PXI-6683 Series is completely software configurable. The system software automatically allocates all module resources.

The two LEDs on the front panel provide information about module status. The [PXI-6683 Front Panel and LEDs](#) on page 9 section describes the LEDs in greater detail.

Hardware Overview

This chapter presents an overview of the hardware functions of the PXI-6683 Series, shown in [Figure 1](#), on page 7.

Figure 1. Isometric View of the PXI-6683 Series

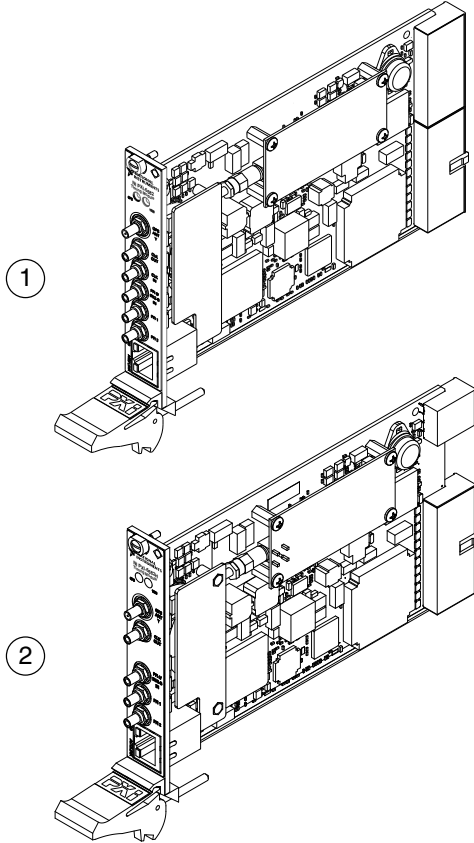

1. PXI-6683
2. PXI-6683H

[Figure 2](#), on page 8 provides a functional overview of the PXI-6683 Series:

Figure 2. Functional Overview of the PXI-6683

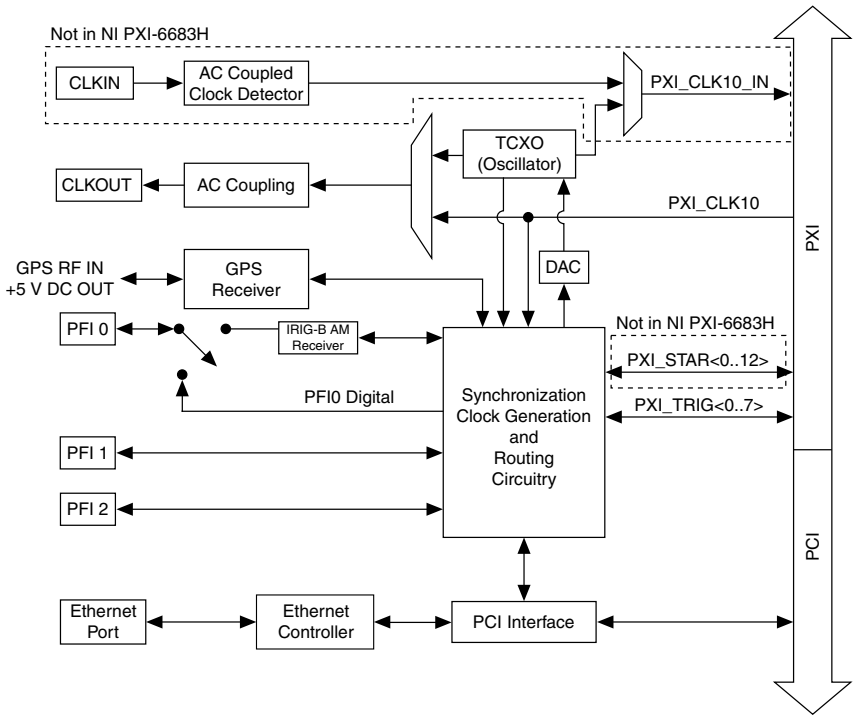

Note The PXI-6683H does not have PXI_STAR trigger lines, shown as *PXI_STAR<0..12>* in [Figure 2](#), on page 8. The PXI-6683H does not have the CLKIN circuitry, or the ability to drive PXI_CLK10_IN.

PXI-6683 Front Panel and LEDs

Figure 3. PXI-6683 Front Panel

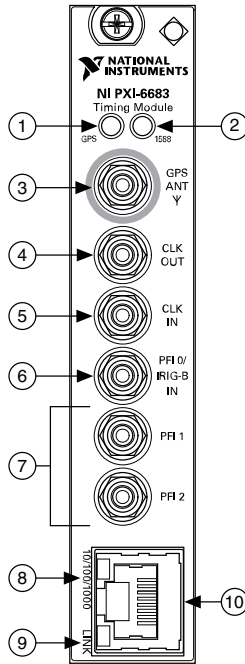

1. GPS LED
2. 1588/802.1AS LED
3. GPS Antenna Connector
4. CLKOUT Connector
5. CLKIN Connector
6. PFI0/IRIG-B Input Connector
7. PFI<1..2> Connectors
8. Ethernet Speed LED
9. Ethernet ACT/LINK LED
10. RJ-45 Ethernet Connector

The GPS LED indicates the status of the GPS hardware.

Table 2. GPS LED Color Description

Color	Status
Off	Not using GPS*
Amber	Attempting to start self survey
Blinking Amber	Self survey in progress
Blinking Green	Self survey complete (normal operation)
Red	Error [†]

*The GPS LED is turned off if GPS is not set as the time reference.

[†]An error is generated when the antenna is disconnected, when there is an antenna malfunction, or when there is a hardware malfunction.

The 1588/802.1AS LED indicates the status of the IEEE 1588 or 802.1AS synchronization protocol.

Table 3. 1588/802.1AS LED Color Description

Color	Status
Off	Not using 1588 or 802.1AS*
Amber	Initializing
Blinking Amber (2 seconds)	Listening or Passive
Green	Uncalibrated or Slave
Blinking Green (2 seconds)	Master or Premaster
Red	Faulty

*1588 and/or 802.1AS has been disabled or stopped.

The Ethernet Speed LED indicates the PXI-6683 Series Ethernet link speed.

Table 4. Ethernet Speed LED Description

Color	Status
Off	10 Mbps
Green	100 Mbps
Amber	1000 Mbps

The Ethernet ACT/LINK LED indicates the PXI-6683 Series Ethernet link condition.

Table 5. Ethernet ACT/LINK LED

Color	Status
Off	No Ethernet link
Green	Ethernet link established
Blink	Ethernet activity occurring

Connectors

This section describes the connectors on the front panel of the PXI-6683 Series. Refer to [Figure 3](#), on page 9 for the location of the connectors.

- **GPS ANT**—GPS antenna RF input and DC power output for the active GPS antenna. This connector provides 5 VDC for an active antenna. This connector also serves as the input for the RF signal coming in from the GPS antenna.
- **CLKOUT**—Clock Output. This connector is used to source a 10 MHz clock that can be routed programmatically from the temperature-compensated crystal oscillator (TCXO) or backplane clock (PXI_CLK10).
- **CLKIN**—Clock Input. This connector supplies the module with a clock that can be programmatically routed to the PXI backplane (PXI_CLK10_IN) for distribution to the other modules in the chassis when the PXI-6683 is installed in the system timing slot.



Note The PXI-6683H does not have the CLKIN connector.

- **PFI<0..2>**—Programmable Function Interface <0..2>. These connectors can be used for either input or output. You can program the behavior of these PFI connections individually. Additionally, PFI0 can function as an input for IRIG-B DC or AM.



Caution Do not connect an AM signal to PFI0 when the PFI line is configured for digital operations. This could cause damage to the digital circuitry, the device driving the AM signal, or both. Always ensure the line is configured for IRIG-B AM operation before connecting an IRIG-B AM signal.

- **RJ-45 Ethernet**—10/100/1000 Mbit Ethernet connection. This connector allows the module to communicate via standard Ethernet cabling.



Caution Connections that exceed any of the maximum ratings of input or output signals on the PXI-6683 Series can damage the module, the computer, or other devices connected to the PXI-6683 Series. National Instruments is not liable for any damage resulting from such signal connections.

Hardware Features

The PXI-6683 Series performs the following functions:

- Synchronization using GPS, IRIG-B, PPS, IEEE 1588, or IEEE 802.1AS.
- Generation of future time events and clock signals, based on the synchronized time.
- Timestamping incoming signals with the synchronized time.

- Routing internally or externally generated signals from one location to another.
- Single-board clock disciplining capability.

[table] outlines the function and direction of the signals discussed in detail in the remainder of this section. These signals are also identified in *Figure 2*, on page 8.

Table 6. PXI-6683 Series I/O Terminals

Signal Name	Direction	Description
PXI_CLK10_IN (System Timing Slot only) (Not in the PXI-6683H)	Out	This is a signal that can replace the native 10 MHz oscillator on the PXI backplane. PXI_CLK10_IN may originate from the onboard TCXO or from an external source connected to CLKIN.
PXI_CLK10	In	This signal is the PXI 10 MHz backplane clock. By default, this signal is the output of the native 10 MHz oscillator in the chassis. A PXI-6683 Series in the system timing slot can replace this signal with PXI_CLK10_IN.
Oscillator	N/A	This is the output of the 10 MHz TCXO. It is used by the FPGA for synchronization. A PXI-6683 in the system timing slot can be routed to CLKOUT or PXI_CLK10_IN. The TCXO is a very stable and accurate frequency source.
CLKIN (Not in the PXI-6683H)	In	CLKIN is a signal connected to the SMB input pin of the same name. A PXI-6683 in the system timing slot can route CLKIN to PXI_CLK10_IN.
CLKOUT	Out	CLKOUT is the signal on the SMB input pin of the same name. Either the oscillator (TCXO) or PXI_CLK10 may be routed to this output.
PXI_STAR<0..12> (Not in the PXI-6683H)	In/Out	The PXI star trigger bus connects the system timing slot to Slot<3..15> in a star configuration. The electrical paths of each star line are closely matched to minimize intermodule skew. A PXI-6683 in the system timing slot can route signals to Slots<3..15> using the star trigger bus.

Table 6. PXI-6683 Series I/O Terminals (Continued)

Signal Name	Direction	Description
PFI<0..2>	In/Out	The Programmable Function Interface (PFI) pins on the PXI-6683 Series route timing and triggering signals between multiple PXI chassis. A wide variety of input and output signals can be routed to or from the PFI lines. PFI<0> can also function as an input for IRIG-B DC or AM.
PXI_TRIG<0..7>	In/Out	The PXI trigger bus consists of eight digital lines shared among all slots in the PXI chassis. The PXI-6683 Series can route a wide variety of signals to and from these lines.

The remainder of this section describes how these signals are used, acquired, and generated by the PXI-6683 Series hardware, and explains how you can use the signals between various locations to synchronize events in your system.

Clock and Event Generation

The PXI-6683 Series can generate two types of clock signals. The first type is generated with a precise 10 MHz oscillator, and the second is generated with the synchronized timebase. The following sections describe the two types of clock generation and explain the considerations for choosing either type. In addition to time-synchronized clock signals, the PXI-6683 Series is also capable of generating arbitrary digital events, to be used as triggers.

TCXO, PXI_CLK10, and Clock Disciplining

The PXI-6683 Series features a precision 10 MHz TCXO. The frequency accuracy and stability of this clock is greater than the frequency accuracy and stability of the native 10 MHz PXI backplane clock (PXI_CLK10).

The main source of error in most frequency reference oscillators is temperature variation. The TCXO contains circuitry to measure the temperature of the oscillator and adjust the oscillator's control voltage to compensate for temperature variations according to the crystal's known frequency variation across its operating temperature range.

A PXI-6683 module in the system timing slot of a PXI chassis can replace the native PXI 10 MHz backplane frequency reference clock (PXI_CLK10) with the more stable and accurate output of the TCXO. All other PXI modules in the chassis that reference the 10 MHz backplane clock benefit from this improved reference. The TCXO does not automatically replace the native 10 MHz clock; this feature must be explicitly enabled in software. The TCXO output can also be routed out to the CLKOUT connector.

The PXI-6683 has the capability to discipline its 10 MHz TCXO to an external time reference (such as GPS, IEEE 1588, or IRIG-B) by monitoring and adjusting the clock relative to the external time reference. The driver software automatically disciplines the TCXO to the

selected time reference. TCXO disciplining can be disabled by setting the time reference to Free Running.



Note Some chassis (including the PXI-103x series) require toggling a hardware switch to enable the system timing module to override PXI_CLK10. Refer to your chassis user manual for more information.

Time-Synchronized Clock and Event Generation

The PXI-6683 Series is capable of generating clock signals and triggers based on the synchronized time base. The PXI-6683 Series keeps an internal time base with 10 ns resolution that can be free running or synchronized to GPS, IEEE 1588, IEEE 802.1AS, IRIG-B, or PPS. The NI-Sync API allows you to schedule triggers to occur at an arbitrary future time (future time events) or clock with high and low times that are multiples of 10 ns (refer to the PXI-6683 Series Specifications for information about limitations). It is also possible to program the start and end time of a clock generated in this way.

Refer to [Table 7](#), on page 16 for a list of destinations for synchronized time clocks and future time events.

PXI_CLK10 Synchronization Design Recommendations

- Minimize Starting and Stopping of PXI_CLK10 Disciplining—From startup, the PXI_CLK10 synchronization can take on the order of minutes to stabilize to the time reference. You should design your application such that PXI10 disciplining runs asynchronous to other programs that might start and stop more frequently. This minimizes the time spend letting the synchronization stabilize and lock.
- Avoid Disrupting PXI_CLK10 Disciplining—While you can use the devices used for PXI_CLK10 disciplining within other applications, you should avoid resetting them or changing the configured time reference. Doing so disrupts the PXI_CLK10 disciplining process.

Routing Signals

The PXI-6683 Series has versatile trigger routing capabilities. It can route signals to and from the front panel, the PXI star triggers, and the PXI triggers. In addition, the polarity of the destination signal can be inverted, which is useful when handling active-low digital signals.

The PXI-6683 Series can replace the PXI backplane's native 10 MHz clock (PXI_CLK10) with its high-stability TCXO, or with a 10 MHz clock signal from the CLKIN connector. The PXI-6683 Series can route the TCXO or PXI 10 MHz reference clock to CLKOUT.



Note Replacing PXI_CLK10 is not supported by the PXI-6683H.

[Figure 4](#), on page 15 summarizes the routing features of the PXI-6683 Series.

Figure 4. High-Level Schematic of PXI-6683 Signal Routing Architecture

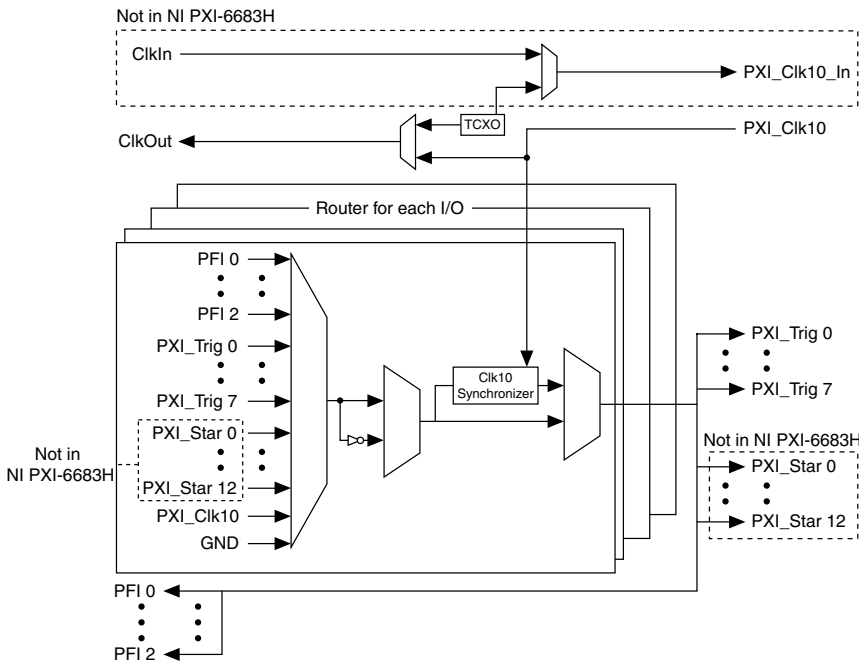

Note The PXI-6683H architecture is identical to the architecture described in the previous figure, except the PXI-6683H does not have PXI_STAR trigger lines, CLKIN, or PXI_CLK10_IN.

Determining Sources and Destinations

All signal routing operations can be characterized by a *source* (input) and a *destination*. In addition, synchronous routing operations must also define a third signal known as the *synchronization clock*. Refer to the [Choosing the Type of Routing](#) section for more information on synchronous versus asynchronous routing.

[Table 7](#), on page 16 summarizes the sources and destinations of the PXI-6683 Series. The destinations are listed in the horizontal heading row, and the sources are listed in the column at the far left. A check in a cell indicates that the source and destination combination defined by that cell is a valid routing combination.

Table 7. Sources and Destinations for PXI-6683 Series Signal Routing Operations

			Destinations				
			Front Panel		Backplane		
			CLKOUT	PFI<0..2>	PXI_CLK10_IN*	PXI_Star Trigger <0..12>*	PXI TRIG <0..7>
Sources	Front Panel	CLKIN*	X [†]	X [†]	X	X [†]	X [†]
		PFI<0..2>		X		X [‡]	X
	Backplane	PXI_CLK10	X	X		X	X
		PXI_STAR<0..12>*		X [‡]		X	X
		PXI TRIG<0..7>		X		X	X
	Onboard	TCXO	X	X [†]	X	X [†]	X [†]
		Time-synchronized events and clocks		X		X	X

*The PXI-6683H does not have a CLKIN connector, PXI_CLK10_IN, or PXI_STAR trigger lines.

[†]Can be accomplished in two stages by routing source to PXI_CLK10_IN, replacing PXI_CLK10 with PXI_CLK10_IN (occurs automatically in most chassis), and then routing PXI_CLK10 to the destination. The source must be 10 MHz.

[‡]Asynchronous routes between a single source and multiple destinations are very low skew. See the PXI-6683(H) Specifications for details.

I/O Considerations

Using the Ethernet Port

The PXI-6683 Series provides on standard RJ-45 connection for Ethernet communication. This port auto negotiates to the best possible speed—10 Mbps, 100 Mbps, or 1000 Mbps (auto-negotiation can be disabled by software). The Ethernet port is auto-MDI capable, which means crossover cabling is not necessary when connecting the PXI-6683 Series to another network card. The PXI-6683 Series senses whether a crossed connection is needed and performs the action internally. The Ethernet port also allows for full duplex operation, so traffic can be sent and received at the same time.

Using Front Panel PFI Terminals as Outputs

The front panel PFI output signals use +3.3 V signaling for high-impedance loads. You can use the PFI terminals to generate future time events and clock signals up to 1.5 MHz. PFI output signals are suitable for driving most LEDs. To ensure proper signal integrity, use cables with 50 Ω loads, although logic-high voltage will be lower than 3.3 V. Refer to the PXI-6683(H) specifications for more information. Refer to NI-Sync for information on how to set up the PFI lines for output.



Caution Do not attempt to drive signals into PFI terminals set up as outputs. Doing so can damage the PXI-6683 Series or the device driving the PFI terminal.

The signal source for each PFI trigger line configured as an output can be independently selected from one of the following options:

- Another PFI<0..2>
- PXI_TRIG<0..7>
- PXI_STAR<0..12> (PXI-6683 only)
- Future time events
- PXI_CLK10
- Ground



Tip Invert Ground to get a logic high.

The PFI trigger outputs may be synchronized to CLK10 except when routing future time events. Refer to the [Choosing the Type of Routing](#) section for more information about the synchronization clock.

Using Front Panel PFI Terminals as Inputs

The front panel PFI terminals can be configured by software to accept input signals. Refer to the NI-Sync documentation for information on how to set up the PFI terminals to accept input signals. You can use these terminals to timestamp triggers with the synchronized system time or to route signals to other destinations (refer to [Table 7](#), on page 16). The input terminals accept native +3.3 V signaling, but are +5 tolerant. Use 50 Ω source termination when driving signals into PFI terminals.

The voltage thresholds for the front panel PFI input signals are fixed. Refer to the PXI-6683 Series Specifications for the voltage thresholds. The front panel PFI input signals can be timestamped on rising, falling, or both edges of an input signal.

PFI0 and SSR Switching

Since PFI0 is a dual-purpose terminal capable of performing digital I/O like the other PFI lines while also being capable of receiving IRIG-B AM and DC inputs, care is taken to protect the digital circuitry when PFI0 is being used as an IRIG-B AM input. This is achieved with a normally-open solid-state relay (SSR), which is closed only when digital operations for the line are enabled through the API. Digital operations include setting up routes in which PFI0 is the source or the destination, enabling timestamping for PFI0, scheduling future time events or clocks for PFI0, and setting IRIG-B DC as the time reference.

The SSR has a 5 ms open and close time. Therefore, care must be taken when using PFI0 to ensure correct operation when the SSR is switching.

To avoid issues due to the SSR switching, follow these guidelines:

- Whenever timestamping begins on PFI0, either ensure the input will remain at a logic low state for at least 5 ms or disregard timestamps for at least 5 ms.
- When setting up PFI0 as an output (future time events or clocks), ensure that PFI0 is driven low for at least 5 ms after the line is set up. Alternately, ensure that the external receiver can tolerate a slow rising edge.

- Before disabling PFI0 set up as an output, drive the output low to avoid a very slow ramp down.
- Any time a route is set up or changed where PFI0 is the source or the destination, allow for a 5 ms settling time.

For more information, refer to KnowledgeBase 4E9BT88P at ni.com/support.

Brief Overview of PXI Synchronization Features

PCI eXtensions for Instrumentation (PXI) is a rugged PC-based platform that offers a high-performance, low-cost deployment solution for measurement and automation systems. PXI combines the Peripheral Component Interconnect (PCI) electrical bus with the rugged, modular Eurocard mechanical packaging of CompactPCI and adds specialized synchronization buses and key software features.

Figure 5. on page 18 provides an overview of the PXI synchronization architecture:

Figure 5. PXI Synchronization Architecture

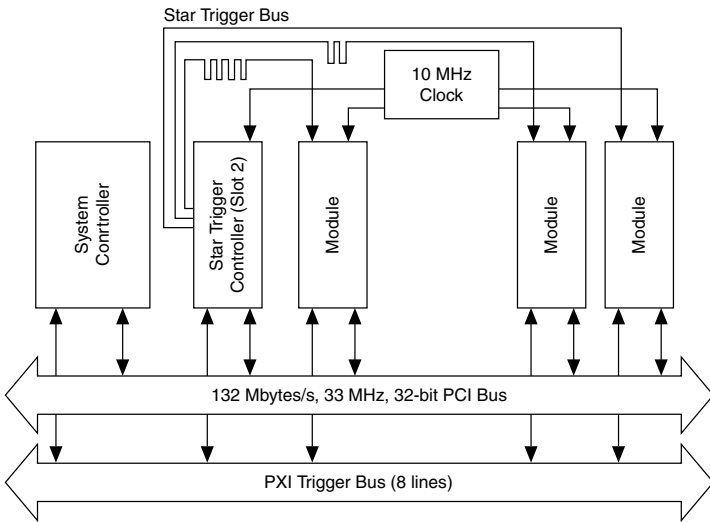

The PXI trigger bus, PXI star triggers, and PXI_CLK10 are PXI features that enhance synchronization. The PXI trigger bus is a multi-drop 8-line bus that goes to every slot. The PXI star trigger bus is a set of up to 13 point-to-point matched-length connections between the system timing slot and every slot starting with slot 3 and up to slot 15. The propagation delay between the system timing slot and each destination slot is matched to within 1ns to achieve low-skew triggering. PXI_CLK10 is a high quality 10 MHz clock that is distributed with low skew to each PXI slot. This 10 MHz signal can be sourced from the native PXI backplane oscillator or from the system timing slot controller module installed in the system timing slot (such as the PXI-6683).

Using the PXI Triggers

The PXI trigger bus is a set of 8 electrical lines that go to every slot in a segment of a PXI chassis (multi-drop up to 8 slots). Only one PXI module should drive a particular PXI_Trigger line at a given time. The signal is then received by modules in all other PXI slots. This feature makes the PXI triggers convenient in situations where you want, for instance, to trigger several devices, because all modules will receive the same trigger.

Given the architecture of the PXI trigger bus, triggering signals do not reach each slot at precisely the same time. A difference of several nanoseconds can occur between slots, especially in larger PXI chassis (which can have buffers between segments). This delay is not a problem for many applications. However, if your application requires tighter synchronization, use the PXI_STAR triggers, or use the PXI trigger bus synchronous to PXI_CLK10.

The multi-drop nature of the PXI trigger bus can introduce signal integrity issues. Therefore, National Instruments does not recommend the use of PXI_Trigger lines for clock distribution. The preferred method for clock distribution is the use of the PXI_STAR triggers. However, the PXI-6683 Series does support routing of clocks to the PXI_Trigger lines, in case you must use them.

For each PXI_Trigger line configured as an output in the PXI-6683 Series, the signal source can be independently selected from the following options:

- PFI<0..2>
- Another PXI trigger line (PXI_TRIG<0..7>)
- PXI_STAR<0..12>
- Future time events
- PXI_CLK10
- Ground



Tip Invert Ground to get a logic high.

The PXI trigger outputs may be synchronized to CLK10 except when routing future time events. Refer to the Choosing the Type of Routing section for more information about the synchronization clock.

Using the PXI Star Triggers (PXI-6683 Only)

There are up to 13 PXI star triggers per chassis. Each trigger line is a dedicated connection between the system timing slot and one other slot. The PXI Specification, Revision 2.1, requires that the propagation delay along each star trigger line be matched to within 1 ns. A typical upper limit for the skew in most NI PXI chassis is 500 ps. The low skew of the PXI star trigger bus is useful for applications that require triggers to arrive at several modules nearly simultaneously. The PXI-6683 is able to route low skew triggers to the PXI_Star lines from any PFI line.

The star trigger lines are bidirectional, so signals can be sent to the system timing slot from a module in another slot or from the system timing slot to the other module.

The signal source for each PXI star trigger line configured as an output can be independently selected from one of the following options:

- PFI<0..2> (low skew)
- PXI_TRIG<0..7>
- Another PXI star trigger line (PXI_STAR<0..12>)
- Synchronized time event
- PXI_CLK10
- Ground



Tip Invert Ground to get a logic high.

The PXI star trigger outputs may be synchronized to CLK10 except when routing future time events. Refer to the Choosing the Type of Routing section for more information about the synchronization clock.

Choosing the Type of Routing

The PXI-6683 Series routes signals in one of two ways: asynchronously or synchronously. The following sections describe the two routing types and the considerations for choosing each type.

Asynchronous Routing

Asynchronous routing is the most straightforward method of routing signals. Any asynchronous route can be defined in terms of two signals: a *source* and a *destination*. A digital pulse or train comes in on the source and is propagated to the destination. When the source signal goes from low to high, this rising edge is transferred to the destination after a propagation delay through the module. [Figure 6](#), on page 20 illustrates an asynchronous routing operation.

Figure 6. Asynchronous Routing Operation

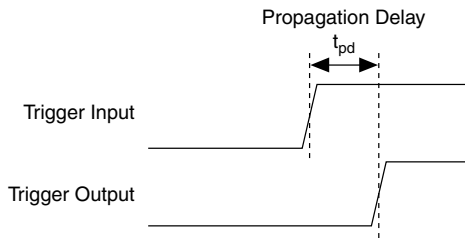

Some delay is always associated with an asynchronous route, and this delay varies among PXI-6683 Series modules, depending on variations in temperature and chassis voltage. Typical delay times in the PXI-6683 Series for asynchronous routes between various sources and destinations are given in the device's Specifications.

Asynchronous routing works well if the total system delays are not too long for the application. Propagation delay could be caused by the following reasons:

- Output delay on the source.
- Propagation delay of the signal across the backplane(s) and cable(s).
- Propagation delay of the signal through the PXI-6683 Series.
- Time for the receiver to recognize the signal.

The source of an asynchronous routing operation on the PXI-6683 Series can be any of the following lines:

- Any front panel PFI pin (PFI<0..2>)
- Any PXI Star trigger line (PXI_STAR<0..12>) (PXI-6683 only)
- Any PXI trigger line (PXI_TRIG<0..7>)
- Synchronized time events
- PXI_CLK10
- Ground



Tip Invert Ground to get a logic high.

The destination of an asynchronous routing operation on the PXI-6683 Series can be any of the following lines:

- Any front panel PFI pin (PFI<0..2>)
- Any PXI star trigger line (PXI_STAR<0..12>) (PXI-6683 only)
- Any PXI trigger line (PXI_TRIG<0..7>)

Synchronous Routing

A synchronous routing operation is defined in terms of three signals: a *source*, a *destination*, and a *synchronization clock*. Unlike asynchronous routing, the output of a synchronous routing operation does not directly follow the input after a propagation delay. Instead, the logic state of the input is sampled on each active edge of the synchronization clock, and the output is set to that logic state after a small delay, as shown in [Figure 7](#), on page 22. Thus, the output is said to be *synchronous* with this clock.

[Figure 7](#), on page 22 shows a timing diagram that illustrates synchronous routing.

Figure 7. Synchronous Routing Operation

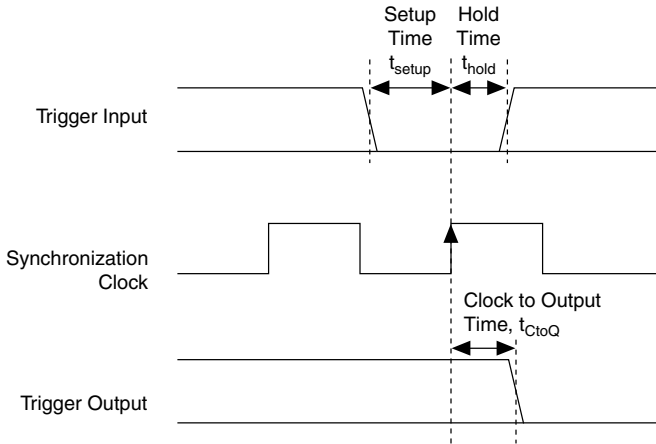

The PXI-6683 Series supports synchronous routing to either the rising or falling edge of the synchronization clock. In addition, the polarity of the destination signal can be inverted, which is useful when handling active-low digital signals. Synchronous routing can be useful for eliminating skew when sending triggers to several destinations. For example, when sending triggers using the PXI Trigger lines, the trigger arrives at each slot at a slightly different time. However, if the trigger is sent and received synchronously using a low-skew synchronization clock (for example, PXI_CLK10), all receiving devices can act on the trigger at the same time, as shown in [Figure 8](#). on page 22:

Figure 8. Synchronous Routing to Multiple Destinations

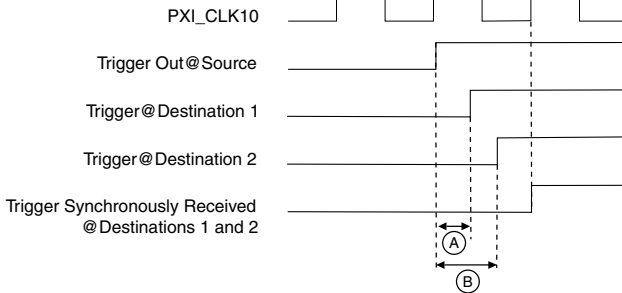

- A: Propagation delay from source to destination 1.
- B: Propagation delay from source to destination 2.

Synchronous routing requires the input to be stable at a logic low or logic high state with a window of time around the clock edge. This window of time around the clock edge is defined by the setup time (t_{setup}) and hold time (t_{hold}). If the input signal changes within this window of time, it is undetermined whether the output of the synchronous route will go to the old or new logic state. This is important, for example, if a source is being routed synchronously to

several destinations. If the source signal changes within the setup-and-hold window around the synchronization clock edge, one of the destinations might go to the new logic level while the other destination might remain at the old logic level and change when the next synchronization clock edge occurs, as shown in *Figure 9*, on page 23:

Figure 9. Synchronous Routing Uncertainty with Setup-and-Hold Variations

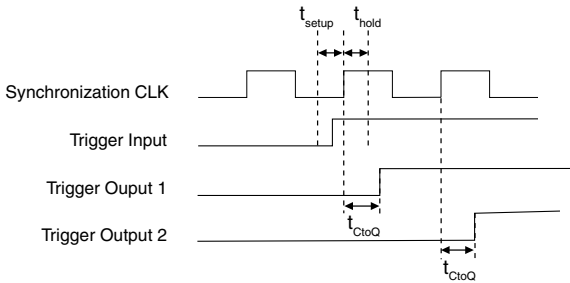

Therefore, if your application requires that the trigger arrive at the multiple destinations simultaneously, you must ensure that the input is stable within the setup and hold window around the synchronization clock edge. For more information and possible methods to ensure this requirement is met, go to ni.com/info and enter the Info Code `SyncTriggerRouting`.

Possible sources for synchronous routing with the PXI-6683 Series include the following sources:

- Any front panel PFI pin. (PFI<0..2>)
- Any PXI star trigger line (PXI_STAR<0..12>) (PXI-6683 only)
- Any PXI trigger line (PXI_TRIG<0..7>)

In the PXI-6683 Series, the synchronization clock for synchronous routes is always PXI_CLK10.

The destination of a synchronous routing operation on the PXI-6683 Series can be any of the following lines:

- Any front panel PFI pin (PFI<0..2>)
- Any PXI star trigger line (PXI_STAR<0..12>) (PXI-6683 only)
- Any PXI trigger line (PXI_TRIG<0..7>)



Note The possible destinations for a synchronous route are identical to those for an asynchronous route.

Synchronization

The PXI-6683 Series is capable of achieving tight synchronization with various other devices using GPS, IRIG-B, PPS, IEEE 802.1AS, or IEEE 1588. When GPS or IRIG-B are selected as the synchronization source, the PXI-6683 Series module can also serve as an IEEE 1588 grandmaster. The following sections describe the synchronization capabilities of the PXI-6683 Series.

GPS

GPS stands for Global Positioning System, and it is a system of over two dozen satellites in medium Earth orbit that are constantly transmitting signals down to Earth. GPS receivers are able to detect these signals and determine location, speed, direction, and time very precisely. GPS satellites are fitted with atomic clocks, and the signals they transmit to Earth contain timing information. This makes the GPS system a precise timing and synchronization source.

The PXI-6683 Series has a GPS receiver which powers an active GPS antenna and receives and processes the RF signals (1.575 GHz) from the satellites. The GPS receiver then generates a very precise pulse-per-second (PPS) signal that the PXI-6683 Series uses to achieve sub-microsecond synchronization.

GPS enables the PXI-6683 Series to synchronize PXI systems located far away from each other, as long as GPS satellites are visible to the antenna from each location. Furthermore, once the PXI-6683 Series is synchronized to GPS, it can function as an IEEE 1588 grandmaster to enable synchronization of external 1588 devices.

IRIG-B

IRIG is a standard used to transmit precise timing information between instruments to achieve synchronization. IRIG-B is a particular application of the IRIG standard, in which 100 bits of data are sent every second. Embedded in the data is a seconds' boundary marker that the receiving instrument uses to synchronize its timebase to the IRIG source. The rest of the data contains information such as the time of day, days since the beginning of the year, and optionally, control functions and the number of seconds since the start of the day, encoded as a straight binary number.

The PXI-6683 Series can function as an IRIG-B receiver, supporting synchronization to sources outputting IRIG-B 12X (AM) and IRIG-B 00X (DC), compliant with the IRIG 200-04 standard.

When configured to synchronize to an IRIG-B AM source, the PXI-6683 Series will be able to accept a 1 kHz AM modulated IRIG-B 12X signal on its PFI0 input. When configured to synchronize to an IRIG-B DC source, the PXI-6683 Series will be able to accept an IRIG-B 00X DC encoded signal on its PFI0 input.



Caution Do not connect an AM signal to PFI0 when the PFI line is configured for digital operations. This could cause damage to the digital circuitry, the device driving the AM signal, or both. Always ensure the line is configured for IRIG-B AM operation before connecting an IRIG-B AM signal.

Furthermore, once the PXI-6683 Series is synchronized to IRIG-B, it can function as an IEEE 1588 grandmaster to synchronize external 1588 devices.

The following assumptions are made regarding the received IRIG-B signal. All conditions must be met for the PXI-6683 Series to be able to synchronize accurately:

- Seconds begin every minute at 0, increment to 59, and then roll over to 0.
- Minutes begin every hour at 0, increment to 59, and then roll over to 0.

- Hours begin every day at 0, increment to 23, and then roll over to 0.
- Days begin every year at 1. Days increment to 365 in non-leap years, or to 366 in leap years, and then roll over to 1. Leap years must be supported. Valid values for year are 01 to 99, inclusive. Years are assumed to be in the 21st century. For instance, year 19 represents 2019. If the year is not supplied (sent as 00), the OS system time is read and the year is derived from it.

To achieve proper synchronization of the PXI-6683 Series, ensure that the IRIG-B source used conforms to the requirements listed above. Note that most IRIG-B sources conform to these requirements.

802.1AS

The IEEE 802.1AS generalized precision time protocol (gPTP) is a standard based on IEEE 1588 that is better optimized for time-sensitive applications. Like 1588, 802.1AS controls synchronization across a series of nodes connected by Ethernet cables, switches, and bridges by automatically designating a grandmaster clock using the Best Master Clock algorithm (BMCA). The grandmaster clock then serves as the source of time to slave devices (devices not elected as the 1588 grandmaster) across the network.

Each distributed device runs the BMCA to determine the highest ranking, most accurate device on the network, which automatically becomes the grandmaster. If the grandmaster clock leaves the network or is no longer the most accurate clock on the network, the BMCA selects a new grandmaster. The BMCA defines a standard set of clock characteristics—such as the origin of a clock's time source and the stability of the clock's frequency—and then assigns a value to each clock in order to determine the grandmaster. The BMCA also takes into account user-defined priority values, which you can set using the NI-Sync driver software.

One of the main differences between 802.1AS and 1588 is that 802.1AS requires 802.1AS-capable network switches and network interfaces providing hardware-assisted timestamping in order to operate. You can determine whether or not a device is capable of running 802.1AS using the AS Capable property, accessible with NI-Sync.

IEEE 1588

The PXI-6683 Series is capable of performing synchronization over Ethernet using IEEE 1588. It is possible to configure the PXI-6683 Series to synchronize to GPS or IRIG-B and then function as an IEEE 1588 grandmaster. It is also possible to configure the PXI-6683 Series to synchronize to IEEE 1588, in which case, the standard defines how the master will be selected. If the PXI-6683 Series is selected as the IEEE 1588 master, and it is not configured to synchronize to GPS or IRIG-B, it will use its internal free-running timebase, which will be updated to the host computer's system time during power up.

Pulse Per Second (PPS)

The PXI-6683 Series is capable of using a PPS signal for synchronization. Any PFI, PXI_Trigger, or PXI_Star line can be configured as the PPS input terminal. When synchronizing based on a PPS, the first pulse received will set the PXI-6683 Series internal timebase to either an arbitrary time supplied by the user, or the host computer's system time. Each subsequent pulse received will be interpreted as a second's boundary (the pulse occurring

exactly one second after the previous pulse). As each pulse is received, the PXI-6683 Series will adjust its internal timebase to match the frequency of the PPS source.

For best results when using a PPS time reference, ensure that the device supplying the PPS signal is capable of providing a stable, consistent 1 Hz signal. Error can be induced into the system if the reference signal contains significant jitter, or if the reference frequency strays from 1 Hz.

Synchronization Best Practices

The PXI-6683 Series can achieve sub-microsecond synchronization. The following sections describe some guidelines for achieving the best possible performance from the PXI-6683 Series. While the PXI-6683 Series will function properly if you follow the specifications, the following guidelines may increase the synchronization performance.

Operating Environment

In order to achieve the best synchronization performance, refer to the following guidelines to provide a thermally stable environment. Also, ensure you remain within the specified operating temperature limits:

- Place the PXI or PXI Express chassis containing the PXI-6683 Series module in an environment free of rapid temperature transitions.
- Ensure that PXI filler panels are properly installed for unused PXI or PXI Express slots, since consistent airflow can degrade the PXI-6683 Series performance.
- Perform the same steps listed above for any other synchronization partners and/or systems.

Timing System Performance

The PXI-6683 Series can generate or receive a 1 Hz pulse per second signal on any PFI or PXI trigger terminal. You can set up this signal to transition on the seconds boundary of the synchronized system time. You can then use this signal to analyze system performance by connecting two or more pulse per second signals to an oscilloscope and measuring the latency between them. Adjustments can be made to account for deterministic latency; refer to NI-Sync documentation for more information. The PXI-6683 Series can also timestamp an incoming pulse per second signal. The PXI-6683 Series will timestamp the externally-generated pulse per second with its internal timebase. By comparing this timestamp with the nearest seconds boundary, you can quickly determine the synchronization performance.

IEEE 1588 Synchronization Best Practices

Network Topology

To obtain the best PXI-6683 Series performance, follow these guidelines to set up the Ethernet network topology:

- Use short cabling when possible. Ethernet cabling is inherently asymmetric; the longer the cabling, the higher the asymmetry. This impacts synchronization performance, because the IEEE 1588 protocol assumes a symmetrical network path.
- If several 1588 devices need to be synchronized on the same network, use a 1588-enabled switch. 1588-enabled switches are specifically designed to compensate for the varying latency of packets passing through them; thus enhancing synchronization performance.
- If a 1588-enabled switch is not available, use hubs when connecting to multiple IEEE 1588 devices. Unlike standard switches, hubs offer low latency and close to deterministic performance for Ethernet traffic. Standard Ethernet switches can have Ethernet packet latencies vary by hundreds of nanoseconds. This latency uncertainty degrades synchronization performance significantly.
- Ensure that the network is running at 1 Gbps by noting the Ethernet Speed LED status. Synchronization performance is degraded when running at 10 or 100 Mbps.



Note If it is impossible to use a 1000 or 100 Mbps network and you must run IEEE 1588 synchronization using a 10 Mbps network, ensure the network interface of the PXI-6683 Series is explicitly configured for 10 Mbps full duplex operation using the Windows configuration panels.

GPS Synchronization Best Practices

The PXI-6683 Series module has one SMB female connector on its front panel for a GPS active antenna. The connector provides a DC voltage to power the antenna and also serves as input for the GPS RF signal.

Antenna Installation



Caution National Instruments recommends using a lightning arrester in line with the GPS antenna installation to protect the PXI-6683 Series module and the PXI system from possible damage and operators from injury in the event of lightning.

The embedded GPS receiver in the PXI-6683 Series module requires signals from several satellites to compute accurate timing and location. The more satellites available to the receiver, the more accurately it can determine time and location. Therefore, the antenna location should be such that it receives signals from the greatest number of satellites possible. As the number of satellites visible to the antenna decreases, the synchronization performance may also decrease. Choose the antenna location so that the antenna has a clear view of the sky. There is no strict definition for a clear view of the sky, but a suitable guideline is that the GPS antenna should have a straight line of sight to the sky in all directions (360°), down to an imaginary line making a 30° angle with the ground. Locations far from trees and tall buildings that could block or reflect GPS satellite signals are best.

Maximum Cable Length

Maximum cable length depends on the GPS antenna gain and the cable's loss of per unit of distance. National Instruments recommends a GPS signal strength of between -135 dBm and -120 dBm at the PXI-6683 Series module's SMB input. GPS signal strength on the Earth's

surface is typically -130 dBm. Targeting a signal strength of -125 dBm at the SMB input, you can compute the maximum cable length as:

```
Max_cable_loss = -130 dBm + antenna_gain - (-125 dBm)
Max_cable_length = Max_cable_loss / (loss_per_unit_of_distance)
```

For example, if you use an active antenna with gain of 28 dB and RG-58 cable, which has a rated loss at 1.5 GHz of about 0.8 dB/m (24.5 dB/100 ft), the maximum cable length you could use is:

```
Max_cable_loss = -130 dBm + 28 DB - (-125 dBm) = 23 dB
Max_cable_length = 23 dB / (.08 dB/m) ≈ 29 m
```



Note The GPS antenna kit offered by National Instruments comes with a 30 m cable, which has a loss of 15 dB/100 ft, making the total loss in the cable approximately 14.8 dB.

Calibration

This section discusses the calibration of the PXI-6683 and PXI-6683H.

Calibration consists of verifying the measurement accuracy of a device and correcting for any measurement error. The PXI-6683 Series are factory calibrated before shipment at approximately 25 °C to the levels indicated in the Specifications. The associated calibration constants—the corrections that were needed to meet specifications—are stored in the onboard nonvolatile memory (EEPROM). The driver software uses these stored values.

Factory Calibration

All PXI-6683 Series boards go through factory calibration. During that process the TCXO frequency is adjusted so that it matches a reference 10 MHz atomic clock. A calibration constant is then stored in on-board, non-olvatile memory, along with other calibration metadata, such as calibration date and temperature.

The calibration constant is used at start-up when the board is configured for free running mode. When the PXI-6683 Series module is configured to use GPS, IEEE 1588, IEEE 802.1AS, IRIG-B, or PPS as its time reference, the TCXO frequency is adjusted according to the time reference, and the calibration constant is no longer used. If the board returns to free running mode, because it was so configured or the time reference is no longer present, then the last applied TCXO voltage is retained (it does not revert to the calibration constant).



Note If the board is configured to use IEEE 1588 as the time reference and is selected as the 1588 master with 1588's BMCA, the device will be free running and use its calibration constant.

Additional Information

Refer to ni.com/calibration for additional information on NI calibration services.

Information is subject to change without notice. Refer to the *NI Trademarks and Logo Guidelines* at ni.com/trademarks for information on NI trademarks. Other product and company names mentioned herein are trademarks or trade names of their respective companies. For patents covering NI products/technology, refer to the appropriate location: **Help»Patents** in your software, the `patents.txt` file on your media, or the *National Instruments Patent Notice* at ni.com/patents. You can find information about end-user license agreements (EULAs) and third-party legal notices in the readme file for your NI product. Refer to the *Export Compliance Information* at ni.com/legal/export-compliance for the NI global trade compliance policy and how to obtain relevant HTS codes, ECCNs, and other import/export data. NI MAKES NO EXPRESS OR IMPLIED WARRANTIES AS TO THE ACCURACY OF THE INFORMATION CONTAINED HEREIN AND SHALL NOT BE LIABLE FOR ANY ERRORS. U.S. Government Customers: The data contained in this manual was developed at private expense and is subject to the applicable limited rights and restricted data rights as set forth in FAR 52.227-14, DFAR 252.227-7014, and DFAR 252.227-7015.

© 2013—2019 National Instruments. All rights reserved.

373656C-01 October 2, 2019