

INSTALLATION INSTRUCTIONS

NI TB-2635

8x16, 2-Wire Terminal Block for the NI PXI-2529

This guide describes how to install and connect signals to the National Instruments TB-2635 terminal block. Refer to the *NI Switches Getting Started Guide* to determine when to install the terminal block.

Introduction

The TB-2635 terminal block installs in front of the PXI-2529 switch module and has screw terminals that provide access to all rows and columns of the matrix. Connections for the trigger input and trigger output signals also are available.



Caution This terminal block is rated for Measurement Category I and intended to carry signal voltages no greater than 150 V. This module can withstand up to 800 V impulse voltage. Do not use this module for connection to signals or for measurements within Categories II, III, or IV. Do not connect to MAINS supply circuits (for example, wall outlets) of 115 or 230 VAC. Refer to the *NI Switches Getting Started Guide* for more information on measurement categories.

When hazardous voltages ($>42.4 V_{pk}/60 VDC$) are present on any screw terminal, safety low-voltage ($\leq 42.4 V_{pk}/60 VDC$) cannot be connected to any other screw terminal.

Conventions

The following conventions are used in this guide:

»

The » symbol leads you through nested menu items and dialog box options to a final action. The sequence **File»Page Setup»Options** directs you to pull down the **File** menu, select the **Page Setup** item, and select **Options** from the last dialog box.



This icon denotes a note, which alerts you to important information.



This icon denotes a caution, which advises you of precautions to take to avoid injury, data loss, or a system crash.

bold

Bold text denotes items that you must select or click in the software, such as menu items and dialog box options. Bold text also denotes parameter names.

italic

Italic text denotes variables, emphasis, a cross reference, or an introduction to a key concept. This font also denotes text that is a placeholder for a word or value that you must supply.

monospace

Text in this font denotes text or characters that you should enter from the keyboard, sections of code, programming examples, and syntax examples. This font is also used for the proper names of disk drives, paths, directories, programs, subprograms, subroutines, device names, functions, operations, variables, filenames and extensions, and code excerpts.

1. Unpack the Terminal Block

The terminal block is shipped in an antistatic package to prevent electrostatic discharge (ESD) that can damage several components on the terminal block. To avoid such damage when you handle the terminal block, take the following precautions:



Caution *Never* touch the exposed pins of connectors.

- Ground yourself using a grounding strap or by touching a grounded object.
- Touch the antistatic package to a metal part of the chassis before you remove the terminal block from the package.

Remove the terminal block from the package and inspect the terminal block for loose components or any sign of damage. Notify NI if the terminal block appears damaged in any way. Do *not* install a damaged terminal block onto a switch module.

Store the terminal block in the antistatic package when not in use.

2. Verify the Components

Make sure you have the following:

- TB-2635 terminal block
- PXI chassis
- PXI-2529 switch module
- 1/8 in. flathead screwdriver
- Wire cutter
- Wire insulation stripper

3. Connect Signals

To connect signals to the terminal block, complete the following steps while referring to Figure 1.

1. Prepare the signal wire by stripping the insulation no more than 3/16 of an inch.
2. Remove the terminal block top cover screw with a flathead screwdriver.
3. Gently lift the terminal block top cover off the terminal block.
4. Loosen the two screws on the strain-relief bar, leaving plenty of space for the signal wires.
5. Pull the signal wires through the strain-relief opening shown in Figure 1.
6. Connect the safety earth ground to the safety ground lug.
7. Connect the wires to the terminals by inserting the stripped end of the wire into the terminal. Secure the connection by tightening the screw for each terminal. When connecting the signals, refer to the connection diagram in Figure 2.
8. Remove slack in the terminal block wiring by pulling them through the strain-relief bar.
9. Tighten the two screws on the strain-relief bar until the signal wires are secured.
10. Replace the terminal block top cover.
11. Secure the terminal block top cover with the top cover screw.

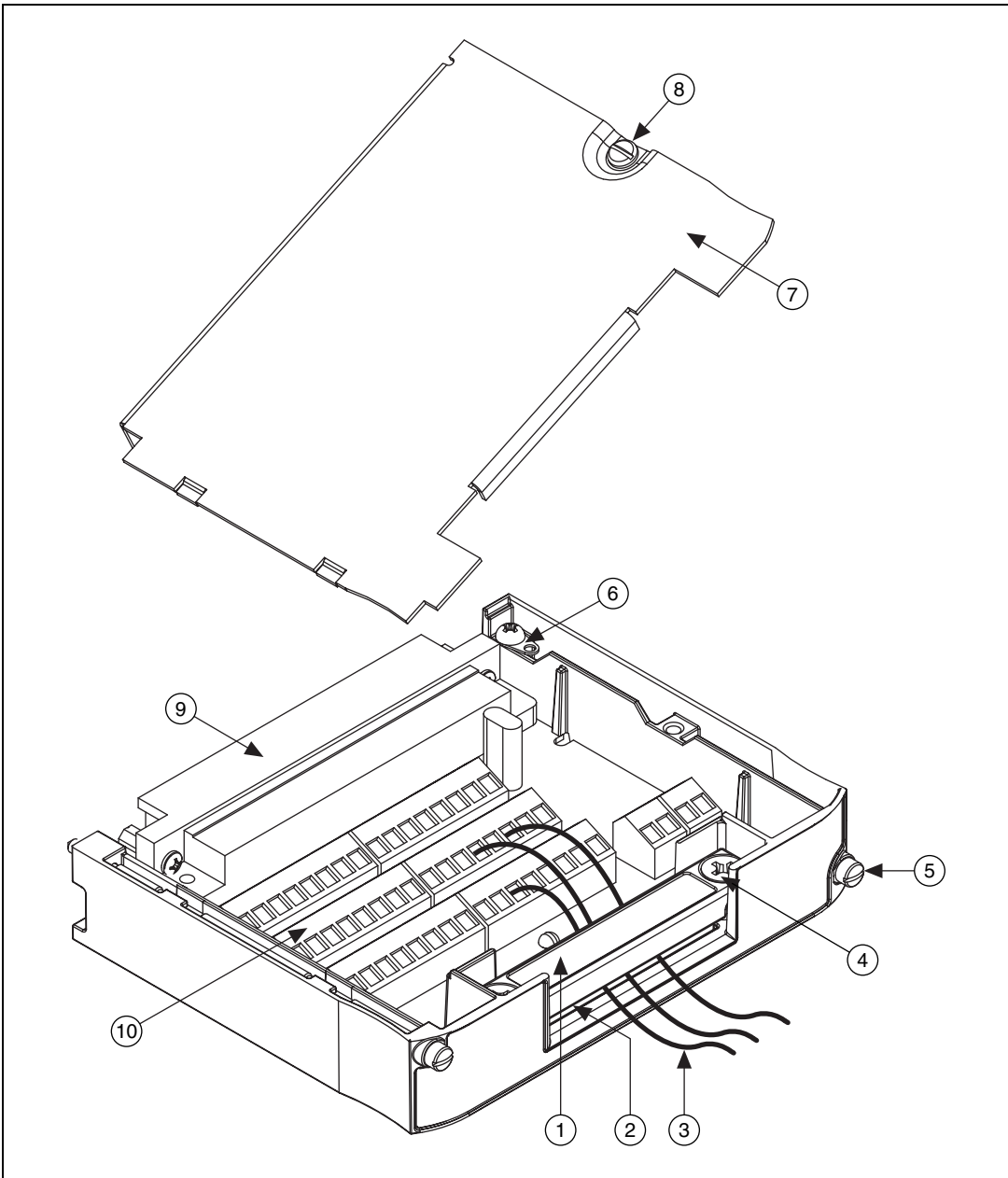

- | | |
|-------------------------|----------------------------|
| 1 Strain-Relief Bar | 6 Safety Ground Lug |
| 2 Strain-Relief Opening | 7 Terminal Block Top Cover |
| 3 Signal Wires | 8 Top Cover Screw |
| 4 Strain-Relief Screw | 9 Rear Connector |
| 5 Jackscrew | 10 Screw Terminals |

Figure 1. TB-2635 Terminal Block



NI TB-2635 Terminal Reference Guide

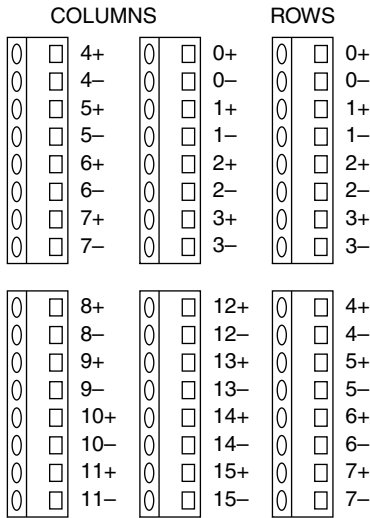

USE SHIELDED CABLE ON TRIGGERS

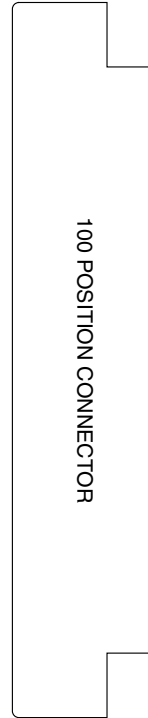

Figure 2. TB-2635 Terminal Reference

4. Install the Terminal Block

To connect the TB-2635 terminal block to the PXI-2529 front panel, complete the following steps while referring to Figure 3.

1. Connect the PXI-2529 front connector to its mating connector on the terminal block.
2. Tighten the top and bottom jackscrews on the back of the terminal block to hold it securely in place. Do *not* overtighten the screws.

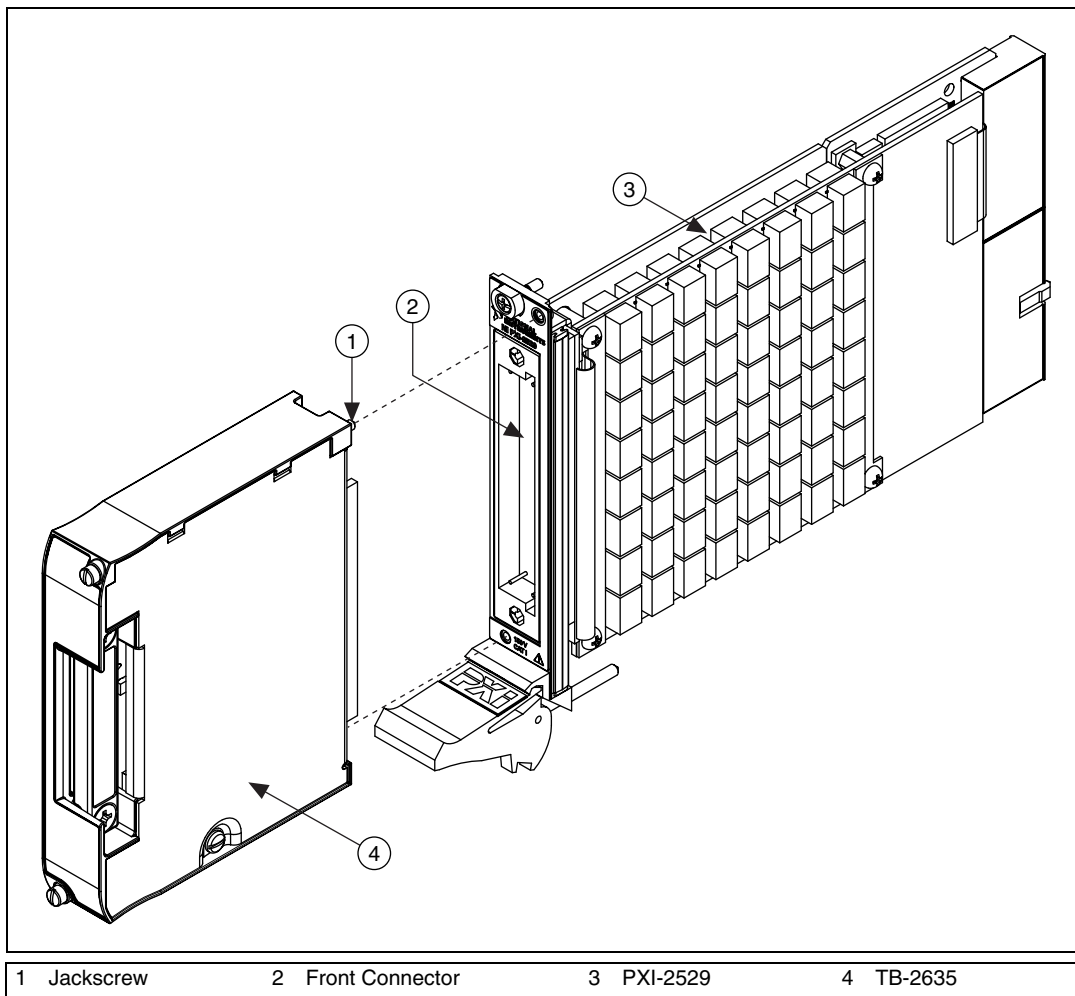

Figure 3. Installing the TB-2635 Terminal Block

Compliance and Certifications

Safety

This product is designed to meet the requirements of the following standards of safety for electrical equipment for measurement, control, and laboratory use:

- IEC 61010-1, EN 61010-1
- UL 3111-1, UL 61010B-1
- CAN/CSA C22.2 No. 1010.1



Note For UL and other safety certifications, refer to the product label or visit ni.com/hardref.nsf, search by model number or product line, and click the appropriate link in the Certification column.

Electromagnetic Compatibility

Emissions	EN 55011 Class A at 10 m FCC Part 15A above 1 GHz
Immunity	EN 61326:1997 + A2:2001, Table 1
EMC/EMI.....	CE, C-Tick, and FCC Part 15 (Class A) Compliant



Note For EMC compliance, you *must* operate this device with shielded cabling.

CE Compliance

This product meets the essential requirements of applicable European Directives, as amended for CE marking, as follows:

Low-Voltage Directive (safety)	73/23/EEC
Electromagnetic Compatibility Directive (EMC)	89/336/EEC



Note Refer to the Declaration of Conformity (DoC) for this product for any additional regulatory compliance information. To obtain the DoC for this product, visit ni.com/hardref.nsf, search by model number or product line, and click the appropriate link in the Certification column.

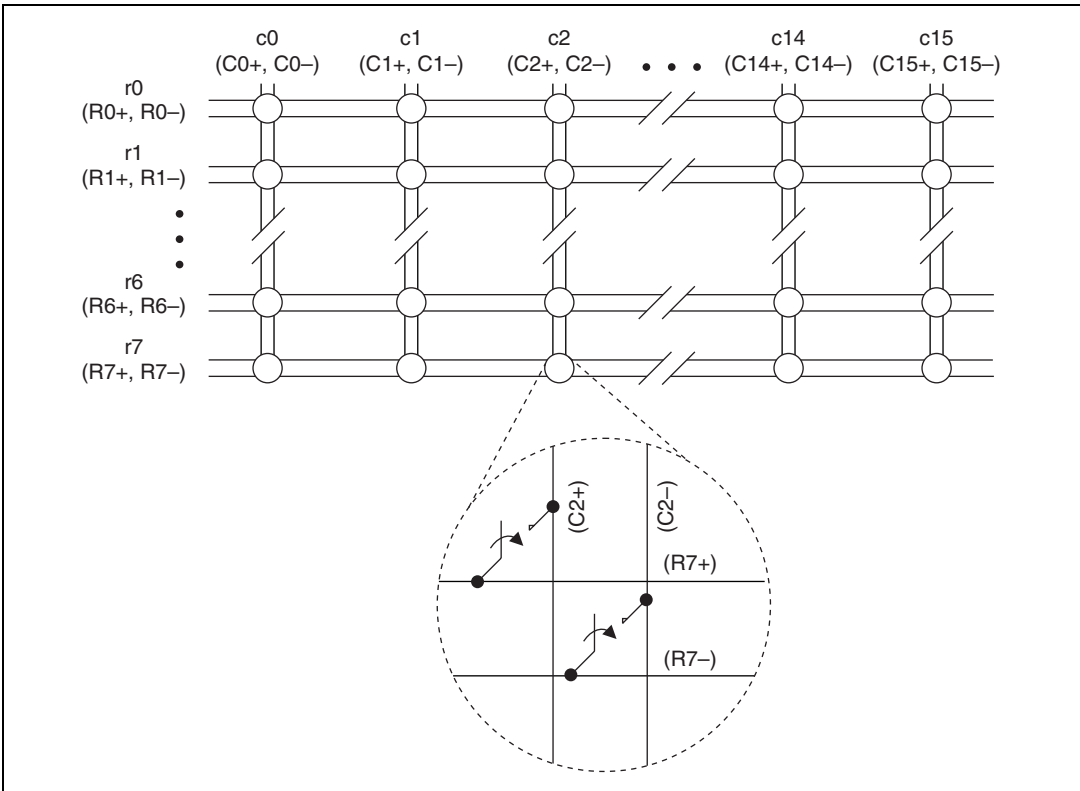

Figure 4. NI TB-2635 8x16, 2-Wire Matrix

