

OPERATING INSTRUCTIONS

CompactRIO™ cRIO-9002/9004

Intelligent Real-Time Embedded Controllers for CompactRIO

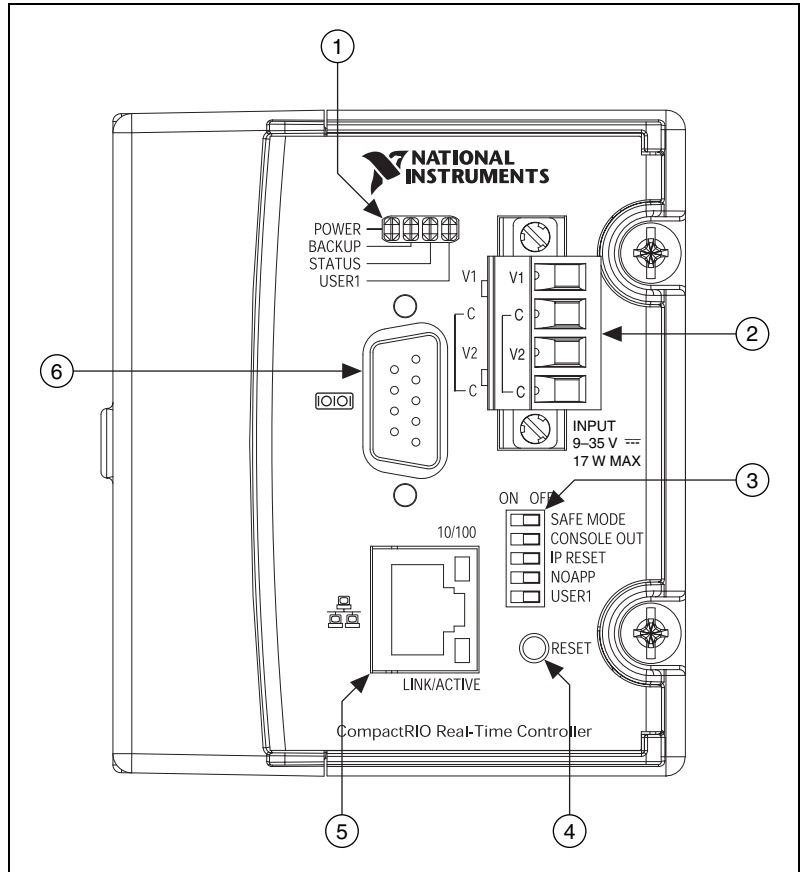

- | | |
|-------------------|-----------------------|
| 1 LEDs | 4 Reset Button |
| 2 Power Connector | 5 RJ-45 Ethernet Port |
| 3 DIP Switches | 6 RS-232 Serial Port |

Figure 1. CompactRIO cRIO-9002/9004

These operating instructions describe how to connect the National Instruments cRIO-9002 and cRIO-9004 to a network and how to use the features of the cRIO-9002 and cRIO-9004. For information about installing, configuring, and programming the controller, refer to the *CompactRIO Bookshelf* at **Start»All Programs»National Instruments»CompactRIO»Search the CompactRIO Bookshelf**.

Safety Guidelines

Operate the cRIO-9002/9004 only as described in these operating instructions.

Safety Guidelines for Hazardous Locations

The cRIO-9002/9004 is suitable for use in Class I, Division 2, Groups A, B, C, and D hazardous locations; Class I, Zone 2, AEx nC IIC T4, and Ex nC IIC T4 hazardous locations; and nonhazardous locations only. Follow these guidelines if you are installing the cRIO-9002/9004 in a potentially explosive environment. Not following these guidelines may result in serious injury or death.



Caution Do *not* disconnect the power supply wires and connectors from the controller unless power has been switched off.



Caution Do *not* install or remove the controller unless power has been switched off.



Caution Substitution of components may impair suitability for Class I, Division 2.



Caution For Zone 2 applications, install the CompactRIO system in an enclosure rated to at least IP 54 as defined by IEC 60529 and EN 60529.

Special Conditions for Safe Use in Europe

This equipment has been evaluated as EEx nC IIC T4 equipment under DEMKO Certificate No. 03 ATEX 0324020X. Each controller is marked  II 3G and is suitable for use in Zone 2 hazardous locations.

Installing the Controller on the Chassis

Figure 2 shows the dimensions of the CompactRIO controller.

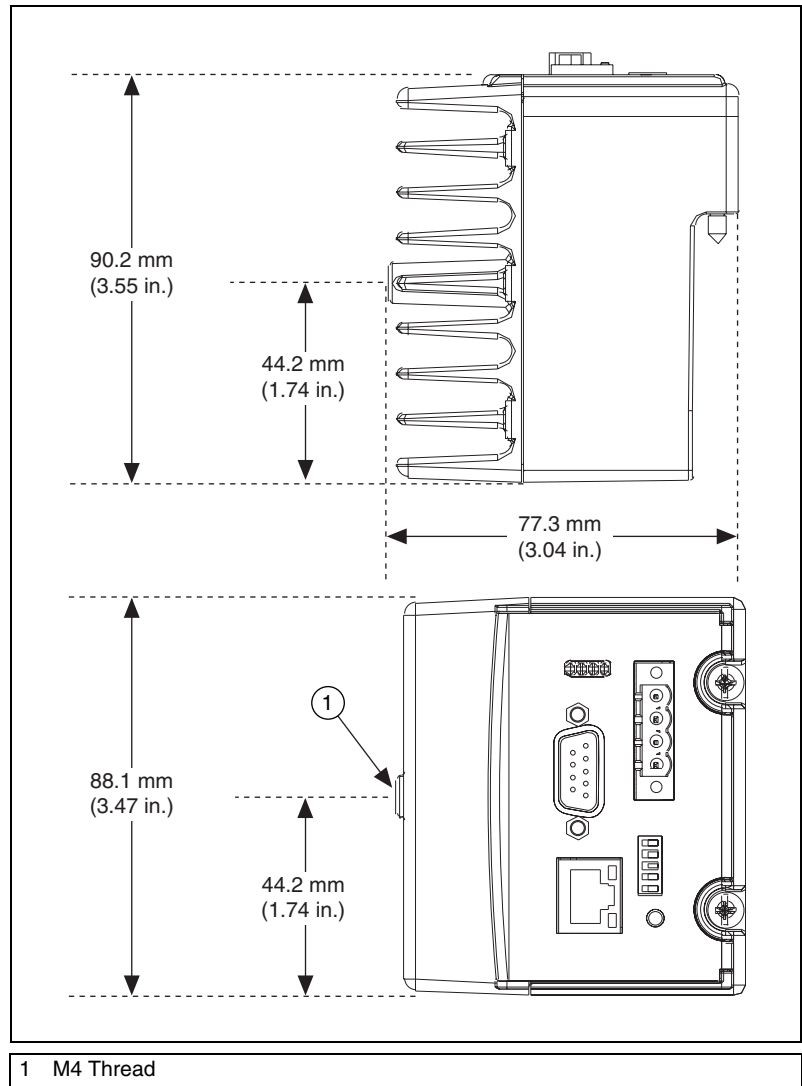

Figure 2. CompactRIO Controller, Front and Bottom Views with Dimensions

Complete the following steps to install the controller on the chassis.

1. Make sure that no power is connected to the controller or the chassis.
2. Align the controller with the chassis as shown in Figure 3.

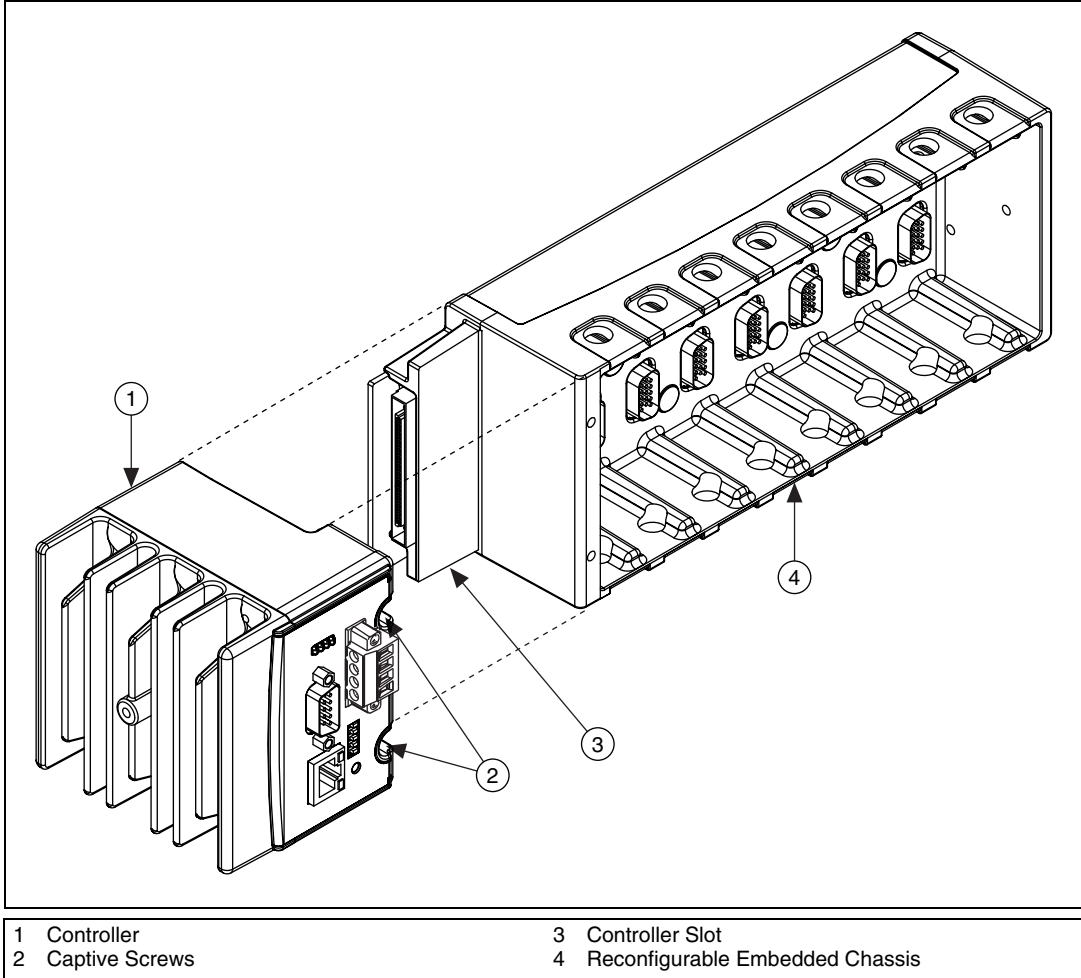

Figure 3. Installing the Controller on the Chassis (Eight-Slot Chassis Shown)

3. Slide the controller onto the controller slot on the chassis. Press firmly to ensure the chassis connector and the controller connector are mated.
4. Using a number 2 Phillips screwdriver, tighten the two captive screws on the front of the controller to 1.3 N · m (11.5 lb · in.) of torque.

Connecting the Controller to a Network

Connect the controller to an Ethernet network using the RJ-45 Ethernet port on the controller front panel. Use a standard Category 5 (CAT-5) Ethernet cable to connect the controller to an Ethernet hub, or use an Ethernet crossover cable to connect the controller directly to a computer.



Caution To prevent data loss and to maintain the integrity of your Ethernet installation, do *not* use a cable longer than 100 m. If you are using 100 Mbps Ethernet, National Instruments recommends using a CAT-5 shielded twisted-pair Ethernet cable.

The host computer communicates with the controller over a standard Ethernet connection. If the host computer is on a network, you must configure the controller on the same subnet as the host computer. If neither the host computer nor the CompactRIO controller is connected to a network, you can connect the two directly using a CAT-5 crossover cable.

If you need to build your own cable, refer to the [Cabling](#) section for more information about Ethernet cable wiring connections.

In order to configure the controller, you must connect it to the same subnet as the host computer. If you want to use the controller on a subnet other than the one the host computer is on, first connect the controller on the same subnet as the host computer. Use DHCP to assign an IP address or reassign a static IP address for the subnet where you want it to be and physically move it to the other subnet. The first time you configure the controller, you must also install software on it. Refer to the *Measurement & Automation Explorer Help* for more information about configuring the controller in Measurement & Automation Explorer (MAX). Contact your network administrator if you need assistance configuring the host computer and controller on the same subnet.

Wiring Power to the Controller



Caution You *must* install the controller on a CompactRIO chassis and tighten the captive screws before you apply power to the controller. Installing the controller while power is applied to it can cause damage to the chassis.

The controller requires an external power supply that meets the specifications in the [Power Requirements](#) section. The controller filters and regulates the supplied power and provides power for all of the I/O modules in the chassis. You can connect two power sources to the controller. The controller draws power from the power source with the higher voltage. The controller has one layer of reversed-voltage protection. The power source

you connect to the controller must provide an additional layer of reversed-current flow protection. Complete the following steps to connect power sources to the controller.

1. Install a ferrite across the negative and positive wires for both the V1 and V2 terminals. Refer to Figure 4 for an illustration of this step.
2. Connect the positive lead of one of the power sources to the V1 terminal and the negative lead to one of the C terminals.
3. Connect the positive lead of the other power source to the V2 terminal and the negative lead to one of the C terminals.



Note The controller draws power from *either* V1 or V2 depending on which terminal has a higher voltage. It does not draw power from both terminals.



Caution The C terminals are internally connected to each other. Make sure to use two power sources that have a common ground.

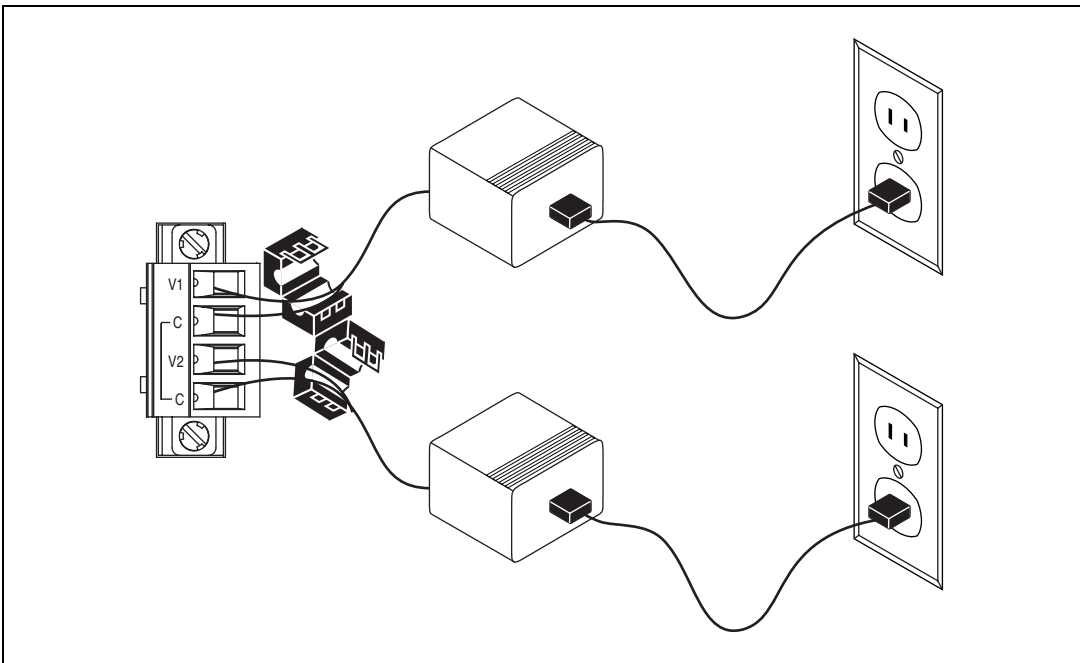

Figure 4. Wiring Power to the Controller

Powering On the Controller

Plug in each power supply to the CompactRIO system. The controller runs a power-on self test (POST). During the POST, the Power, Status, and User1 LEDs turn on. The User1 and Status LEDs turn off, indicating that the POST is complete. If the LEDs do not behave in this way when the controller powers on, refer to the [Understanding LED Indications](#) section.

Boot Options

You can configure the controller to launch an embedded stand-alone application each time you boot the controller. Refer to the *LabVIEW Real-Time Module User Manual* for more information.

Table 1 lists the reset options available on CompactRIO backplanes, such as the cRIO-910x devices. Use these options to determine how the CompactRIO controllers, such as the cRIO-9002 and cRIO-9004 controllers, are reset in various conditions.

Table 1. CompactRIO Reset Options

Backplane Reset Option	Controller Behavior
Do Not Autoload on Reset	Does not load the FPGA bit stream from flash memory
Autoload on Power-On Reset	Loads the FPGA bit stream from flash memory to the FPGA when the controller powers on.
Autoload on Any Device Reset	Loads the FPGA bit stream from flash to the FPGA when you reboot the controller either with or without cycling power.

Connecting Serial Devices to the Controller

The controller has an RS-232 serial port to which you can connect devices such as displays or input devices. Use the Serial VIs to read from and write to the serial port. For more information about the Serial VIs, refer to the *LabVIEW Help*.

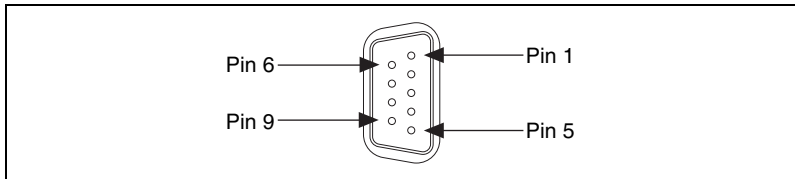

Figure 5. Controller Serial Port

Table 2. DB-9 Pin Descriptions

Pin	Signal
1	DCD
2	RXD
3	TXD
4	DTR
5	GND
6	DSR
7	RTS
8	CTS
9	RI

Configuring DIP Switches

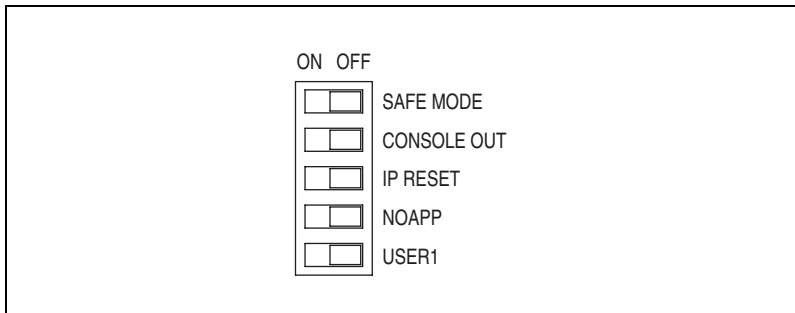

Figure 6. Controller DIP Switches

All of the DIP switches are in the OFF position when the controller is shipped from National Instruments.

Safe Mode Switch

The position of the Safe Mode switch determines whether the embedded LabVIEW Real-Time engine launches when the controller boots. If the switch is in the OFF position, the LabVIEW Real-Time engine launches. Keep this switch in the OFF position during normal operation. If the switch is in the ON position when the controller boots, the controller launches only the essential services required for updating its configuration and installing software. The LabVIEW Real-Time engine does not launch.

Push the Safe Mode switch to the ON position if the software on the controller is corrupted. If there is no software installed on the controller, the controller automatically boots into safe mode regardless of the position of the safe mode switch. The Safe Mode switch must be in the ON position to reformat the drive on the controller. Refer to the *Measurement & Automation Explorer Help* for more about installing software on a controller and the reformatting the drive on the controller.

Console Out Switch

With a serial-port terminal program, you can use the Console Out switch to read the IP address and BIOS version of the controller. Connect the serial port on the controller to a computer. Push the switch to the ON position. Make sure that the serial-port terminal program is configured to the following settings:

- 9,600 bits per second
- Eight data bits
- No parity
- One stop bit

The serial-port terminal program displays the IP address and BIOS version. Keep this switch in the OFF position during normal operation.

IP Reset Switch

Push the IP Reset switch to the ON position and reboot the controller to reset the IP address of the controller to 0 . 0 . 0 . 0 . If the controller is on your local subnet and the IP Reset switch is in the ON position, the controller appears in MAX with IP address 0 . 0 . 0 . 0 . You can configure a new IP address for the controller in MAX. Refer to the [Resetting the Network Configuration of the Controller](#) section for more information about resetting the IP address. You also can push this switch to the ON position to unlock a controller that was previously locked in MAX.

No App Switch

Push the No App switch to the ON position to prevent a LabVIEW startup application from running on the controller when the controller powers on. If you want to permanently disable the application from running when the controller powers on, you must disable it in LabVIEW. To run an application when the controller powers on, push the No App switch to the OFF position, create an application using the LabVIEW Application Builder, and configure the application in LabVIEW to launch when the controller powers on. If you already have an application configured to launch when the controller powers on and you push the No App switch from ON to OFF, the power-on application is automatically enabled. For more information about automatically launching VIs when the controller powers on and disabling VIs from launching when the controller powers on, refer to the *LabVIEW Real-Time Module User Manual*.

User1 Switch

You can define the behavior of the User1 switch for your application. To define the behavior of this switch in your embedded application, use the RT Read Switch VI in your LabVIEW RT embedded VI. For more information about the RT Read Switch VI, refer to the *LabVIEW Help*.

Understanding LED Indications

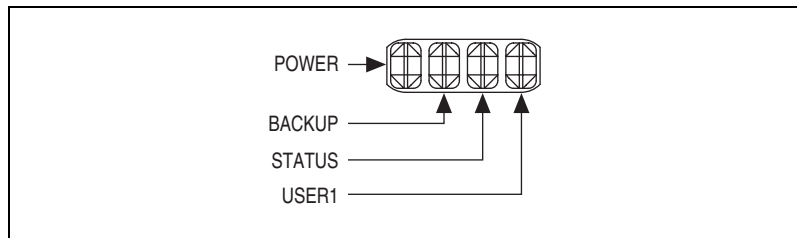

Figure 7. CompactRIO Controller LEDs

Power LED

The Power LED is lit while the controller is powered on. This LED indicates that the power supply connected to the controller is adequate, and that the controller is supplying power to the CompactRIO system.

Backup LED

The Backup LED is lit when the controller is drawing power from the V2 terminal.

Status LED

The Status LED is off during normal operation. The controller indicates specific error conditions by flashing the Status LED a certain number of times as shown in Table 3.

Table 3. Status LED Indications

Number of Flashes	Indication
Slow, continuous flashing (one flash every couple seconds)	The controller is unconfigured. Use MAX to configure the controller. Refer to the <i>Measurement & Automation Explorer Help</i> for information about configuring the controller.
2	The controller has detected an error in its software. This usually occurs when an attempt to upgrade the software is interrupted. Reinstall software on the controller. Refer to the <i>Measurement & Automation Explorer Help</i> for information about installing software on the controller.
3	The controller is in safe mode because the Safe Mode DIP switch is in the ON position. Refer to the Configuring DIP Switches section for information about the Safe Mode DIP switch.
4	The controller software has crashed twice without rebooting or cycling power between crashes. This usually occurs when the controller runs out of memory. Review your RT VI and check the controller memory usage. Modify the VI as necessary to solve the memory usage issue.
Continuous flashing	The controller has detected an unrecoverable error. Contact National Instruments.
Continuously lit	The flash memory card on the controller is corrupt. Reformat the hard drive on the controller. Refer to <i>Measurement & Automation Explorer Help</i> for more information about reformatting the hard drive.

User1 LED

You can define the User1 LED to meet the needs of your application. To define the LED, use the RT LEDs VI in LabVIEW. For more information about the RT LEDs VI, refer to the *LabVIEW Help*.

Resetting the Network Configuration of the Controller

If the controller is not able to communicate with the network, you can manually restore the unit to the factory network settings. When you reset the controller, the IP address, subnet mask, DNS address, gateway, and Time Server IP are set to 0 . 0 . 0 . 0. Resetting does not affect power-on defaults, watchdog settings, or VIs.

Complete the following steps to reset the controller.

1. Move the IP Reset DIP switch to the ON position.
2. Push the Reset button to cycle power to the controller. The Status LED flashes once, indicating that the controller IP address is unconfigured.
3. Move the IP Reset switch to the OFF position.

The controller settings are reset. You can reconfigure the settings in MAX from a computer on the same subnet. Refer to the *Measurement & Automation Explorer Help* for more information about configuring the controller.

Specifications

The following specifications are typical for the range –40 to 70 °C unless otherwise noted.

Network

Network interface	10BaseT and 100BaseTX Ethernet
Compatibility	IEEE 802.3
Communication rates	10 Mbps, 100 Mbps, auto-negotiated
Maximum cabling distance.....	100 m/segment

Memory

cRIO-9002	
Nonvolatile	64 MB
DRAM	32 MB
cRIO-9004	
Nonvolatile	512 MB
DRAM	64 MB

MTBF

The following MTBF specifications apply to the cRIO-9002 and cRIO-9004.

MTBF 1,253,788 hours at 25 °C;
Bellcore Issue 6, Method 1,
Case 3, Parts Count Method



Note Contact NI for Bellcore MTBF specifications at other temperatures or for MIL-HDBK-217F specifications. Go to ni.com/certification and search by model number or product line for more information about MTBF and other product certifications.

Power Requirements

You must use a National Electric Code (NEC) Class 2 power source with the cRIO-9002/9004.

Recommended power supply 48 W secondary,
18 VDC to 24 VDC

Power consumption

Controller only 7 W max
Controller supplying power to
8 CompactRIO modules 17 W

Power supply

On power up 9 to 35 V
After power up 6 to 35 V



Note The cRIO-9002 and cRIO-9004 power up only at 9 V or higher, but when these devices are powered on, they can run on as little as 6 V.

Physical Characteristics

If you need to clean the controller, wipe it with a dry towel.

Screw-terminal wiring 12 to 24 AWG copper conductor
wire with 10 mm (0.39 in.) of
insulation stripped from the end

Torque for screw terminals 0.5 to 0.6 N · m
(4.4 to 5.3 lb · in.)

Weight Approx. 488 g (17.2 oz)

Safety

Safety Voltages

Connect only voltages that are within these limits.

V to C.....35 V max, Measurement
Category I

Measurement Category I is for measurements performed on circuits not directly connected to the electrical distribution system referred to as *MAINS* voltage. MAINS is a hazardous live electrical supply system that powers equipment. This category is for measurements of voltages from specially protected secondary circuits. Such voltage measurements include signal levels, special equipment, limited-energy parts of equipment, circuits powered by regulated low-voltage sources, and electronics.



Caution Do not connect V and C terminals to signals within Measurement Categories II, III, or IV.

Safety Standards

The cRIO-9002/9004 is designed to meet the requirements of the following standards of safety for electrical equipment for measurement, control, and laboratory use:

- EN 61010-1, IEC 61010-1
- UL 61010-1
- CAN/CSA-C22.2 No. 61010-1



Note For UL and other safety certifications, refer to the product label, or visit ni.com/certification, search by model number or product line, and click the appropriate link in the Certification column.

Hazardous Locations

U.S. (UL)Class I, Division 2, Groups A, B, C, D, T4; Class I, Zone 2, AEx nC IIC T4

Canada (C-UL)Class I, Division 2, Groups A, B, C, D, T4; Class I, Zone 2, Ex nC IIC T4

Europe (DEMKO)EEx nC IIC T4

Environmental

The cRIO-9002/9004 is intended for indoor use only. For outdoor use, mount the CompactRIO system in a suitably rated enclosure.

Operating temperature
(IEC 60068-2-1, IEC 60068-2-2) -40 to 70 °C



Note To meet this operating temperature range, follow the guidelines in the installation instructions for your CompactRIO system.

Storage temperature
(IEC 60068-2-1, IEC 60068-2-2) -40 to 85 °C

Ingress protection IP 40

Operating humidity
(IEC 60068-2-56) 10 to 90% RH, noncondensing

Storage humidity
(IEC 60068-2-56) 5 to 95% RH, noncondensing

Maximum altitude 2,000 m

Pollution Degree (IEC 60664) 2

Shock and Vibration

To meet these specifications, you must panel mount the CompactRIO system and affix ferrules to the end of the terminal wires.

Operating vibration,
random (IEC 60068-2-64) 5 g_{rms}, 10 to 500 Hz

Operating shock
(IEC 60068-2-27) 30 g, 11 ms half sine
50 g, 3 ms half sine,
18 shocks at 6 orientations

Operating vibration,
sinusoidal (IEC 60068-2-6) 5 g, 10 to 500 Hz

Electromagnetic Compatibility

Emissions	EN 55011 Class A at 10 m FCC Part 15A above 1 GHz
Immunity	Industrial levels per EN 61326:1997 + A2:2001, Table A.1
EMC/EMI	CE, C-Tick, and FCC Part 15 (Class A) Compliant



Note For EMC compliance, operate this device with shielded cabling.

CE Compliance

This product meets the essential requirements of applicable European directives, as amended for CE marking, as follows:

Low-Voltage Directive (safety).....73/23/EEC

Electromagnetic Compatibility
Directive (EMC).....89/336/EEC



Note Refer to the Declaration of Conformity (DoC) for this product for any additional regulatory compliance information. To obtain the DoC for this product, visit ni.com/certification, search by model number or product line, and click the appropriate link in the Certification column.

Cabling

Table 4 shows the standard Ethernet cable wiring connections for both normal and crossover cables.

Table 4. Ethernet Cable Wiring Connections

Pin	Connector 1	Connector 2 (Normal)	Connector 2 (Crossover)
1	white/orange	white/orange	white/green
2	orange	orange	green
3	white/green	white/green	white/orange
4	blue	blue	blue
5	white/blue	white/blue	white/blue

Table 4. Ethernet Cable Wiring Connections (Continued)

Pin	Connector 1	Connector 2 (Normal)	Connector 2 (Crossover)
6	green	green	orange
7	white/brown	white/brown	white/brown
8	brown	brown	brown

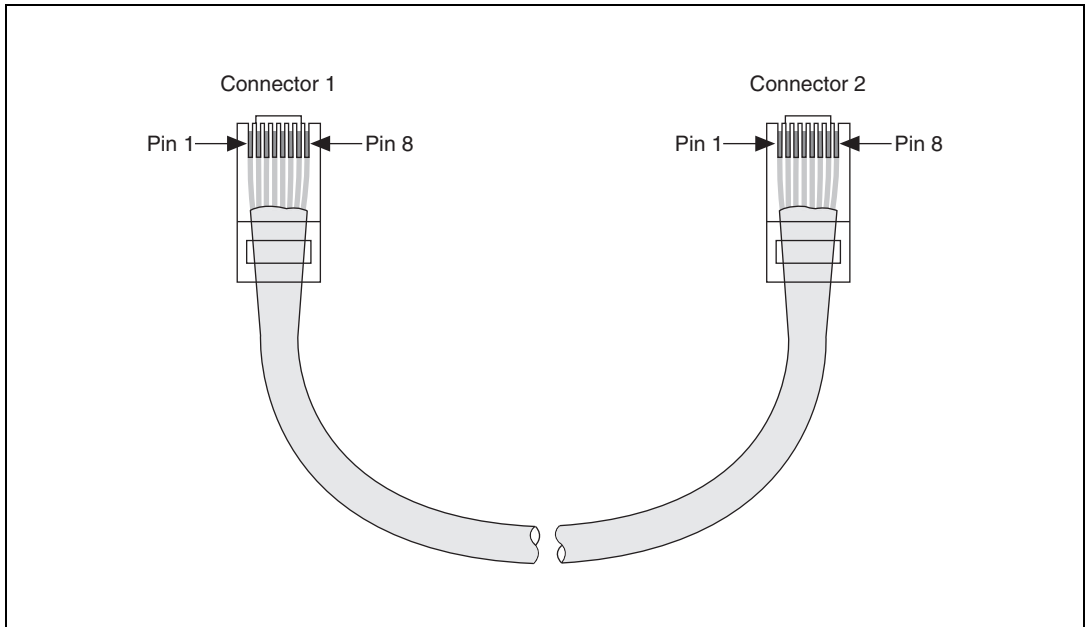

Figure 8. Ethernet Connector Pinout

National Instruments Contact Information

National Instruments corporate headquarters is located at 11500 North Mopac Expressway, Austin, Texas, 78759-3504. National Instruments also has offices located around the world to help address your support needs. For telephone support in the United States, create a service request at ni.com/support and follow the calling instructions or dial 512 795 8248. For telephone support outside the United States, contact your local branch office:

Australia 1800 300 800, Austria 43 0 662 45 79 90 0,
Belgium 32 0 2 757 00 20, Brazil 55 11 3262 3599,
Canada 800 433 3488, China 86 21 6555 7838,
Czech Republic 420 224 235 774, Denmark 45 45 76 26 00,
Finland 385 0 9 725 725 11, France 33 0 1 48 14 24 24,
Germany 49 0 89 741 31 30, India 91 80 51190000,
Israel 972 0 3 6393737, Italy 39 02 413091, Japan 81 3 5472 2970,
Korea 82 02 3451 3400, Lebanon 961 0 1 33 28 28,
Malaysia 1800 887710, Mexico 01 800 010 0793,
Netherlands 31 0 348 433 466, New Zealand 0800 553 322,
Norway 47 0 66 90 76 60, Poland 48 22 3390150,
Portugal 351 210 311 210, Russia 7 095 783 68 51,
Singapore 1800 226 5886, Slovenia 386 3 425 4200,
South Africa 27 0 11 805 8197, Spain 34 91 640 0085,
Sweden 46 0 8 587 895 00, Switzerland 41 56 200 51 51,
Taiwan 886 02 2377 2222, Thailand 662 278 6777,
United Kingdom 44 0 1635 523545

National Instruments, NI, ni.com, and LabVIEW are trademarks of National Instruments Corporation. Refer to the *Terms of Use* section on ni.com/legal for more information about National Instruments trademarks. Other product and company names mentioned herein are trademarks or trade names of their respective companies. For patents covering National Instruments products, refer to the appropriate location: **Help»Patents** in your software, the `patents.txt` file on your CD, or ni.com/patents.