

# OPERATING INSTRUCTIONS AND SPECIFICATIONS

# NI 9472/9474

## 8-Channel Digital Output Modules

Français    Deutsch    日本語    한국어    简体中文

[ni.com/manuals](http://ni.com/manuals)

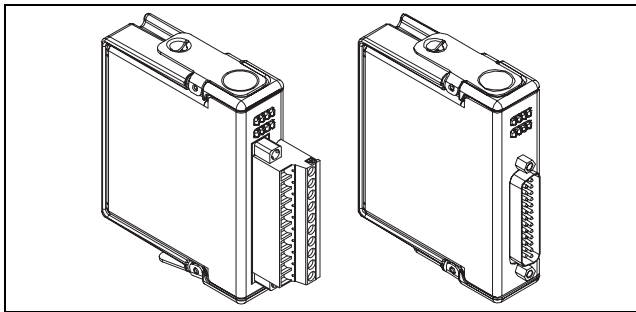

This document describes how to use the National Instruments 9472 and National Instruments 9474 and includes specifications and terminal or pin assignments. In this document, the NI 9472/9474 with screw terminal and NI 9472 with DSUB are referred to inclusively as the NI 9472/9474. Visit [ni.com/info](http://ni.com/info) and enter `rdsoftwareversion` to determine which software you need for the modules you are using. For information about installing, configuring, and programming the system, refer to the system documentation. Visit [ni.com/info](http://ni.com/info) and enter `cseriesdoc` for information about C Series documentation.



**Note** The safety guidelines and specifications in this document are specific to the NI 9472/9474. The other components in the system might not meet the same safety ratings and specifications. Refer to the documentation for each component in the system to determine the safety ratings and specifications for the entire system. Visit [ni.com/info](http://ni.com/info) and enter `cseriesdoc` for information about C Series documentation.

## Safety Guidelines

---

Operate the NI 9472/9474 only as described in these operating instructions.



**Hot Surface** This icon denotes that the component may be hot. Touching this component may result in bodily injury.

## Safety Guidelines for Hazardous Voltages

You can connect hazardous voltages only to the NI 9472/9474 with screw terminal. Do *not* connect hazardous voltages to the NI 9472 with DSUB.

If hazardous voltages are connected to the module, take the following precautions. A hazardous voltage is a voltage greater than  $42.4 V_{pk}$  or 60 VDC to earth ground.



**Caution** Ensure that hazardous voltage wiring is performed only by qualified personnel adhering to local electrical standards.



**Caution** Do *not* mix hazardous voltage circuits and human-accessible circuits on the same module.



**Caution** Make sure that devices and circuits connected to the module are properly insulated from human contact.



**Caution** When module terminals are hazardous voltage LIVE ( $>42.4 V_{pk}/60$  VDC), you must ensure that devices

and circuits connected to the module are properly insulated from human contact. You must use the NI 9932 connector backshell kit to ensure that the terminals are *not* accessible.

Figure 1 shows the NI 9932 connector backshell.



**Note** You can use the NI 9932 connector backshell only with the NI 9472/9474 with screw terminal.

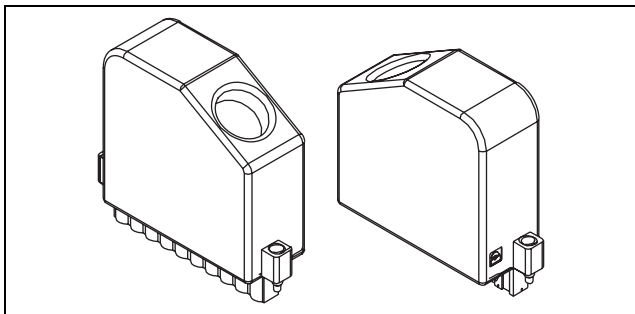

**Figure 1.** NI 9932 Connector Backshell

## Safety Guidelines for Hazardous Locations

The NI 9472/9474 is suitable for use in Class I, Division 2, Groups A, B, C, D, T4 hazardous locations; Class I, Zone 2, AEx nC IIC T4 and Ex nC IIC T4 hazardous locations; and nonhazardous locations only. Follow these guidelines if you are installing the NI 9472/9474 in a potentially explosive environment. Not following these guidelines may result in serious injury or death.



**Caution** Do *not* disconnect I/O-side wires or connectors unless power has been switched off or the area is known to be nonhazardous.



**Caution** Do *not* remove modules unless power has been switched off or the area is known to be nonhazardous.



**Caution** Substitution of components may impair suitability for Class I, Division 2.



**Caution** For Zone 2 applications, install the system in an enclosure rated to at least IP 54 as defined by IEC 60529 and EN 60529.



**Caution** For Zone 2 applications, install a protection device between the  $V_{\text{sup}}$  and COM terminals on the NI 9472/9474. The device must prevent the input  $V_{\text{sup}}$ -to-COM voltage from exceeding 42 V if there is a transient overvoltage condition.

## Special Conditions for Hazardous Locations Use in Europe

This equipment has been evaluated as EEx nC IIC T4 equipment under DEMKO Certificate No. 03 ATEX 0324020X. Each module is marked  $\text{Ex}$  II 3G and is suitable for use in Zone 2 hazardous locations. If you are using the NI 9472/9474 in Gas Group IIC hazardous locations or in ambient temperatures of  $-40\text{ }^{\circ}\text{C} \leq T_a \leq 70\text{ }^{\circ}\text{C}$ , you must use the device in an NI chassis that has been evaluated as EEx nC IIC T4, Ex nA IIC T4, or Ex nL IIC T4 equipment.

## Special Conditions for Marine Applications

Some modules are Lloyd's Register (LR) Type Approved for marine applications. To verify Lloyd's Register certification, visit [ni.com/certification](http://ni.com/certification) and search for the LR certificate, or look for the Lloyd's Register mark on the module.



**Caution** To meet radio frequency emission requirements for marine applications, use shielded cables and install the system in a metal enclosure. Suppression ferrites must be installed on power supply inputs near power entries to modules and controllers. Power supply and module cables must be separated on opposite sides of the enclosure and must enter and exit through opposing enclosure walls.

## Connecting the NI 9472/9474

The NI 9472/9474 provides connections for eight digital output channels.

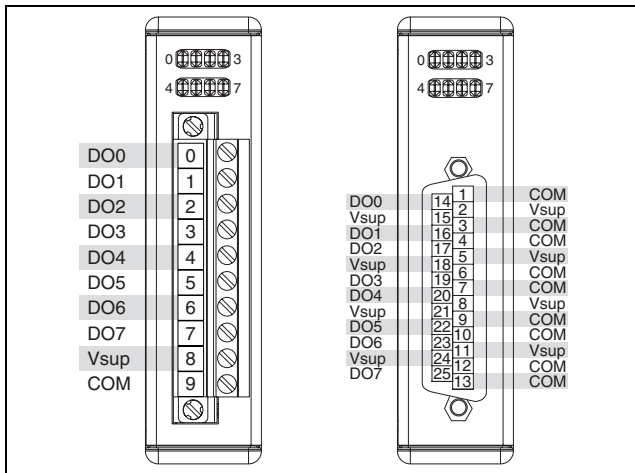

**Figure 2.** NI 9472/9474 Terminal and Pin Assignments

The NI 9472/9474 with screw terminal has a 10-terminal, detachable screw-terminal connector. The NI 9472 with DSUB has a 25-pin DSUB connector. Each channel of the NI 9472/9474 has a terminal or pin, DO, to which you can connect a device. The eight digital output channels are internally referenced to the common terminal or pin, COM. National Instruments recommends you provide independent COM and  $V_{\text{sup}}$  wiring for each channel of the NI 9472 with DSUB to minimize current flow in the COM and  $V_{\text{sup}}$  wiring. The COM pins on the NI 9472 with DSUB are internally connected..



**Note** You must use 2-wire ferrules to create a secure connection when connecting more than one wire to a single terminal on the NI 9472/9474 with screw terminal.

Each channel has an LED that indicates the state of the channel. When a channel LED is lit, the channel is on. When the LED is dark, the channel is off. The LEDs are disabled when the chassis is in sleep mode. Refer to the *Sleep Mode* section for more information about sleep mode.

You must connect an external power supply to the NI 9472/9474. This power supply provides the current for the devices you connect to the module. Connect the positive lead of the power supply to  $V_{\text{sup}}$  and the negative lead of the power supply to COM. The  $V_{\text{sup}}$  pins on the NI 9472 with DSUB are internally connected. You can connect only one external voltage supply to the device. Refer to the [Specifications](#) section for information about the power supply voltage range.



**Caution** Do not remove or insert modules if the external power supply connected to the  $V_{\text{sup}}$  and COM pins is powered on.

The NI 9472/9474 has current sourcing outputs, meaning the DO terminal or pin is driven to  $V_{\text{sup}}$  when the channel is turned on.

You can directly connect the NI 9472/9474 to a variety of industrial devices such as solenoids, motors, actuators, relays, and lamps. Make sure the devices you connect to the NI 9472/9474 are compatible with the output specifications of the module. Refer to the [Specifications](#) section for more information about the output specifications.

Connect the device to DO and connect the common of the device to COM. Refer to Figure 3 for an illustration of how to connect a device to the NI 9472/9474.

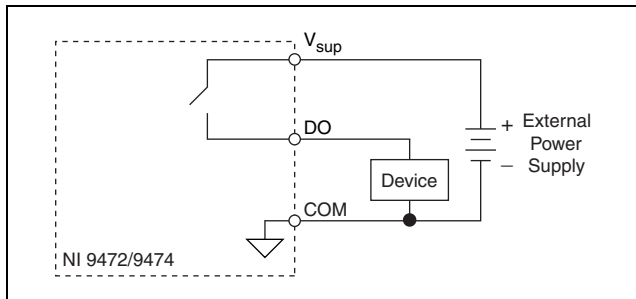

**Figure 3.** Connecting a Device to the NI 9472/9474

## Increasing Current Drive

Each channel of the NI 9472 has a continuous output current of 0.75 A, and each channel of the NI 9474 has a continuous output current of 1 A. If you want to increase the output current to a device, you can connect any number of channels together in parallel. For example, using the NI 9474, if you want to drive 4 A of current, connect DO<0...3> in parallel as shown in Figure 4. You must turn all parallel channels on and off simultaneously so that the current on any single channel cannot exceed the 1 A rating.

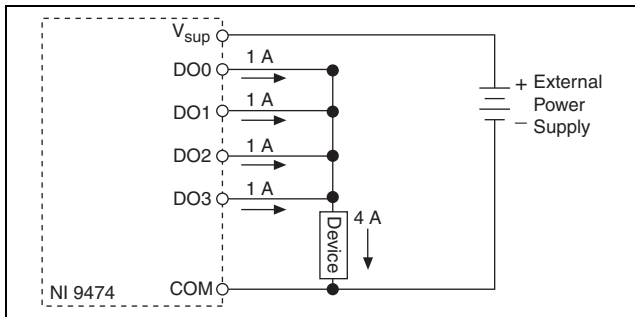

**Figure 4.** Increasing the Current to a Device Connected to the NI 9474

## Wiring for High-Vibration Applications

If an application using the NI 9472/9474 with screw terminal is subject to high vibration, National Instruments recommends that you either use ferrules to terminate wires to the detachable screw-terminal connector or use the NI 9932 backshell kit to protect the connections. Refer to Figure 5 for an illustration of using ferrules. Refer to Figure 1 for an illustration of the NI 9932 connector backshell.

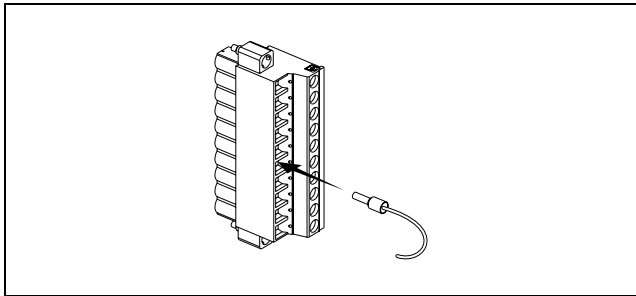

**Figure 5.** 10-Terminal Detachable Screw-Terminal Connector with Ferrule

# I/O Protection

---

The NI 9472/9474 is short-circuit proof in accordance with IEC 1131-2 and provides overcurrent protection.

## Understanding Short-Circuit-Proof Devices

Each channel on the NI 9472/9474 has circuitry that protects it from current surges resulting from short circuits. Whether the module suffers damage from these overcurrent conditions depends on the following factors:

- The amount of current through the channel
- The amount of time the current is above the current limit
- The frequency of the current surges

When the amount of current through the DO terminal or pin is greater than 13 A, the channel trips and goes into an overcurrent state. In an overcurrent state, the channel turns off and the module is not damaged. If the current through DO is between 6 A and 13 A, the state of the channel is indeterminate and depends on factors such as the current level, the temperature, and the power supply.

Higher inrush currents that exist for less than the trip time do not trip the protection circuitry. Refer to the [Specifications](#) section for

more information about the maximum continuous output current, short-circuit behavior, and short-circuit trip time. You also can refer to the IEC 1131-2 standard for more information about short-circuit-proof devices.



**Tip** Because the NI 9472/9474 module includes internal flyback diodes, you do not need to add external diodes when connecting to switching energy storing devices.

## **Power Supplies and Overcurrent Conditions**

If a short-circuit occurs, the current through DO can exceed the current rating for the power supply and the maximum continuous output current for the NI 9472/9474.

If the power supply you are using with the NI 9472/9474 cannot supply more than 13 A, the module may be damaged if a short-circuit condition occurs.

## **Detecting an Overcurrent Condition**

If a device connected to the module is not working while the channel is on, the module channel may be in an overcurrent state. Neither the software nor the module LEDs indicate if an overcurrent condition occurs. A channel LED may be on even if the channel is off because of an overcurrent condition. To determine if

the channel is in an overcurrent state, measure the voltage between DO and  $V_{sup}$ . If the voltage is equal to the voltage of the external power supply connected to the module, the channel is in an overcurrent state.

## Resetting Channels After an Overcurrent Condition

After you have determined and fixed the cause of the overcurrent condition, reset the channel by turning it off. Alternatively, you can disconnect the external power supply from the module. However, doing so disconnects power from all of the module channels. Normal operation can resume after you correct the overcurrent condition and reset the channel.

## Sleep Mode

---

This module supports a low-power sleep mode. Support for sleep mode at the system level depends on the chassis that the module is plugged into. Refer to the chassis manual for information about support for sleep mode. If the chassis supports sleep mode, refer to the software help for information about enabling sleep mode. Visit [ni.com/info](http://ni.com/info) and enter `cseriesdoc` for information about C Series documentation.

Typically, when a system is in sleep mode, you cannot communicate with the modules. In sleep mode, the system consumes minimal power and may dissipate less heat than it does in normal mode. Refer to the *Specifications* section for more information about power consumption and thermal dissipation.

## Specifications

---

The following specifications are typical for the range  $-40$  to  $70$  °C unless otherwise noted. All voltages are relative to COM unless otherwise noted. The specifications are the same for the NI 9472 and the NI 9474 unless otherwise noted.

### Output Characteristics

Number of channels .....	8 digital output channels
Output type .....	Sourcing
Power-on output state .....	Channels off
External power supply voltage range ( $V_{sup}$ )	
NI 9472.....	6–30 VDC
NI 9474.....	5–30 VDC

### Output impedance ( $R_0$ )

Typical ..... 0.07  $\Omega$

Maximum ..... 0.13  $\Omega$

### Continuous output current ( $I_0$ ), per channel

NI 9472..... 0.75 A max

NI 9474..... 1 A max

Output voltage ( $V_0$ ).....  $V_{sup} - (I_0 \cdot R_0)$

### I/O protection

Voltage..... 30 VDC max

Reversed voltage ..... None

### Short-circuit behavior

Current	Channel Behavior	Module Protection
0 to 1 A	Channel does not trip	Module is not damaged
1 to 6 A	Channel does not trip	Module may be damaged
6 to 13 A	Channel may trip	Module may be damaged
>13 A	Channel trips	Module is not damaged

Short-circuit trip time ..... 10  $\mu$ s at 13 A

## Output delay time (full load)

NI 9472.....	100 $\mu$ s max
NI 9474.....	1 $\mu$ s max

## MTBF

NI 9472.....	1,113,301 hours at 25 °C; Bellcore Issue 2, Method 1, Case 3, Limited Part Stress Method
NI 9474.....	479,889 hours at 25 °C; Bellcore Issue 2, Method 1, Case 3, Limited Part Stress Method



**Note** Contact NI for Bellcore MTBF specifications at other temperatures or for MIL-HDBK-217F specifications.

## NI 9472 Power Requirements

### Power consumption from chassis

Active mode .....	230 mW max
Sleep mode .....	0.4 mW max

### Thermal dissipation (at 70 °C)

Active mode .....	1.5 W max
Sleep mode .....	55 mW max

## **NI 9474 Power Requirements**

### Power consumption from chassis

Active mode .....	660 mW max
Sleep mode .....	0.6 mW max

### Thermal dissipation (at 70 °C)

Active mode .....	1.5 W max
Sleep mode .....	0.6 mW max

## **Physical Characteristics**

If you need to clean the module, wipe it with a dry towel.

Screw-terminal wiring .....	12 to 24 AWG copper conductor wire with 10 mm (0.39 in.) of insulation stripped from the end
Torque for screw terminals .....	0.5 to 0.6 N · m (4.4 to 5.3 lb · in.)

Ferrules .....	0.25 mm <sup>2</sup> to 2.5 mm <sup>2</sup>
Weight	
NI 9472/9474 with screw terminal .....	150 g (5.3 oz)
NI 9472 with DSUB .....	145 g (5.1 oz)

## Safety

### NI 9472/9474 with Screw Terminal Safety Voltages

Connect only voltages that are within the following limits.

Channel-to-COM ..... 30 VDC max

#### Isolation

Channel-to-channel ..... None

#### Channel-to-earth ground

    Continuous ..... 250 V<sub>rms</sub>,

    Measurement Category II

    Withstand ..... 2,300 V<sub>rms</sub>, verified by a 5 s  
    dielectric withstand test

Measurement Category II is for measurements performed on circuits directly connected to the electrical distribution system.

This category refers to local-level electrical distribution, such as that provided by a standard wall outlet, for example, 115 V for U.S. or 230 V for Europe.



**Caution** Do *not* connect the NI 9472/9474 with screw terminal to signals or use for measurements within Measurement Categories III or IV.

## NI 9472 with DSUB Safety Voltages

Connect only voltages that are within the following limits.

Channel-to-COM ..... 30 VDC max

Isolation

Channel-to-channel ..... None

Channel-to-earth ground

Continuous ..... 60 VDC,  
Measurement Category I

Withstand ..... 1,000 V<sub>rms</sub>, verified by a 5 s  
dielectric withstand test

Measurement Category I is for measurements performed on circuits not directly connected to the electrical distribution system referred to as *MAINS* voltage. *MAINS* is a hazardous live electrical

supply system that powers equipment. This category is for measurements of voltages from specially protected secondary circuits. Such voltage measurements include signal levels, special equipment, limited-energy parts of equipment, circuits powered by regulated low-voltage sources, and electronics.



**Caution** Do *not* connect the NI 9472 with DSUB to signals or use for measurements within Measurement Categories II, III, or IV.

## Safety Standards

This product is designed to meet the requirements of the following standards of safety for electrical equipment for measurement, control, and laboratory use:

- IEC 61010-1, EN 61010-1
- UL 61010-1, CSA 61010-1



**Note** For UL and other safety certifications, refer to the product label, or visit [ni.com/certification](http://ni.com/certification), search by module number or product line, and click the appropriate link in the Certification column.

## Hazardous Locations

U.S. (UL) .....	Class I, Division 2, Groups A, B, C, D, T4; Class I, Zone 2, AEx nC IIC T4
Canada (C-UL) .....	Class I, Division 2, Groups A, B, C, D, T4; Class I, Zone 2, Ex nC IIC T4
Europe (DEMKO).....	EEx nC IIC T4

## Environmental

National Instruments C Series modules are intended for indoor use only but may be used outdoors if installed in a suitable enclosure. Refer to the manual for the chassis you are using for more information about meeting these specifications.

Operating temperature

(IEC 60068-2-1, IEC 60068-2-2) ..... -40 to 70 °C

Storage temperature

(IEC 60068-2-1, IEC 60068-2-2) ..... -40 to 85 °C

Ingress protection..... IP 40

Operating humidity

(IEC 60068-2-56)..... 10 to 90% RH,  
noncondensing

Storage humidity

(IEC 60068-2-56)..... 5 to 95% RH,  
noncondensing

Maximum altitude..... 2,000 m

Pollution Degree (IEC 60664) ..... 2

## Shock and Vibration

To meet these specifications, you must panel mount the system. If you are using the NI 9472/9474 with screw terminal, you also must either affix ferrules to the ends of the terminal wires or use the NI 9932 backshell kit to protect the connections.

### Operating vibration

Random (IEC 60068-2-64)..... 5 g<sub>rms</sub>, 10 to 500 Hz

Sinusoidal (IEC 60068-2-6) ..... 5 g, 10 to 500 Hz

### Operating shock

(IEC 60068-2-27)..... 30 g, 11 ms half sine,  
50 g, 3 ms half sine,  
18 shocks at 6 orientations

## Electromagnetic Compatibility

This product is designed to meet the requirements of the following standards of EMC for electrical equipment for measurement, control, and laboratory use:

- EN 61326 EMC requirements; Industrial Immunity
- EN 55011 Emissions; Group 1, Class A
- CE, C-Tick, ICES, and FCC Part 15 Emissions; Class A



**Note** For EMC compliance, operate this device with shielded cabling.

## CE Compliance

This product meets the essential requirements of applicable European directives, as amended for CE markings, as follows:

- 2006/95/EC; Low-Voltage Directive (safety)
- 2004/108/EC; Electromagnetic Compatibility Directive (EMC)



**Note** Refer to the Declaration of Conformity (DoC) for this product for any additional regulatory compliance information. To obtain the DoC for this product, visit [ni.com/certification](http://ni.com/certification), search by module number or product line, and click the appropriate link in the Certification column.

## Environmental Management

National Instruments is committed to designing and manufacturing products in an environmentally responsible manner. NI recognizes that eliminating certain hazardous substances from our products is beneficial not only to the environment but also to NI customers.

For additional environmental information, refer to the *NI and the Environment* Web page at [ni.com/environment](http://ni.com/environment). This page contains the environmental regulations and directives with which NI complies, as well as other environmental information not included in this document.

## Waste Electrical and Electronic Equipment (WEEE)



**EU Customers** At the end of their life cycle, all products *must* be sent to a WEEE recycling center. For more information about WEEE recycling centers and National Instruments WEEE initiatives, visit [ni.com/environment/weee.htm](http://ni.com/environment/weee.htm).

## 电子信息产品污染控制管理办法（中国 RoHS）



**中国客户** National Instruments 符合中国电子信息产品中限制使用某些有害物质指令 (RoHS)。关于 National Instruments 中国 RoHS 合规性信息，请登录 [ni.com/environment/rohs\\_china](http://ni.com/environment/rohs_china)。 (For information about China RoHS compliance, go to [ni.com/environment/rohs\\_china](http://ni.com/environment/rohs_china).)

## Where to Go for Support

---

The National Instruments Web site is your complete resource for technical support. At [ni.com/support](http://ni.com/support) you have access to everything from troubleshooting and application development self-help resources to email and phone assistance from NI Application Engineers.

National Instruments corporate headquarters is located at 11500 North Mopac Expressway, Austin, Texas, 78759-3504. National Instruments also has offices located around the world to help address your support needs. For telephone support in the United States, create your service request at [ni.com/support](http://ni.com/support) and follow the calling instructions or dial 512 795 8248. For

telephone support outside the United States, contact your local branch office:

Australia 1800 300 800, Austria 43 662 457990-0,  
Belgium 32 (0) 2 757 0020, Brazil 55 11 3262 3599,  
Canada 800 433 3488, China 86 21 5050 9800,  
Czech Republic 420 224 235 774, Denmark 45 45 76 26 00,  
Finland 358 (0) 9 725 72511, France 01 57 66 24 24,  
Germany 49 89 7413130, India 91 80 41190000,  
Israel 972 3 6393737, Italy 39 02 41309277, Japan 0120-527196,  
Korea 82 02 3451 3400, Lebanon 961 (0) 1 33 28 28,  
Malaysia 1800 887710, Mexico 01 800 010 0793,  
Netherlands 31 (0) 348 433 466, New Zealand 0800 553 322,  
Norway 47 (0) 66 90 76 60, Poland 48 22 3390150,  
Portugal 351 210 311 210, Russia 7 495 783 6851,  
Singapore 1800 226 5886, Slovenia 386 3 425 42 00,  
South Africa 27 0 11 805 8197, Spain 34 91 640 0085,  
Sweden 46 (0) 8 587 895 00, Switzerland 41 56 2005151,  
Taiwan 886 02 2377 2222, Thailand 662 278 6777,  
Turkey 90 212 279 3031, United Kingdom 44 (0) 1635 523545

National Instruments, NI, ni.com, and LabVIEW are trademarks of National Instruments Corporation. Refer to the *Terms of Use* section on [ni.com/legal](http://ni.com/legal) for more information about National Instruments trademarks. Other product and company names mentioned herein are trademarks or trade names of their respective companies. For patents covering National Instruments products, refer to the appropriate location: **Help»Patents** in your software, the `patents.txt` file on your media, or [ni.com/patents](http://ni.com/patents).

© 2003–2008 National Instruments Corp. All rights reserved.

373509E-01

May08