

NI SCXI™-1167 Specifications

64-Channel Relay Driver Module

This document lists specifications for the NI SCXI-1167 relay driver module. All specifications are subject to change without notice. Visit ni.com/manuals for the most current specifications.

Configuration 64 channels, non-latching

Channels are in a bank arrangement, with eight banks of eight channels.

Input Characteristics

Maximum drive voltage,
external power 50 VDC

Maximum drive current
Per channel 600 mA
Per module 25 A

Internal drive power 5 V at 0.75 A

Per-channel protection circuitry

Overvoltage protection activates at 80 V maximum.

Over-current protection activates at 1.5 A minimum.

Over-temperature protection activates at 150 °C junction temperature.

Internal drive power protection circuitry

The 5 V internal power supply has a fuse for over-current protection. This fuse is customer replaceable. Refer to the [Accessories](#) section for fuse ratings.

Dynamic Characteristics

Single-channel operate time
(typical at 25 °C).....60 μ s



Note The operate time is measured from an input trigger to 90% activation of a 500 Ω resistor or between consecutive channel operations.

During power-on or reset, all relay drivers disconnect (power down).

Trigger Characteristics

Input trigger

SourcesSCXI trigger lines 0–7,
Front panel,
Rear connector

Minimum pulse width.....150 ns

Front panel input voltage

Minimum–0.5 V

VL maximum+0.7 V

VH minimum.....+2.0 V

Nominal+3.3 V

Maximum+5.5 V

Output trigger

DestinationsSCXI trigger lines 0–7,
Front panel,
Rear connector

Pulse widthProgrammable (1 μ s to 62 μ s)

Front panel nominal voltage.....3.3 V TTL, 8 mA

Physical Characteristics

I/O connector.....	78-pin D-subminiature
Power requirement, including optional internal drive power	6.3 W at ± 18.5 V 200 mW at 5 V
Dimensions (W \times H \times D).....	3.0 cm \times 17.3 cm \times 19.8 cm (1.2 in. \times 6.8 in. \times 7.8 in.)
Weight.....	700 g (1 lb 9 oz)

Environment

Operating temperature.....	0 °C to 55 °C
Storage temperature	-20 °C to 70 °C
Relative humidity	5% to 85%, noncondensing
Pollution Degree	2
Approved at altitudes up to	2,000 m
Indoor use only	

Accessories



Caution You *must* install mating connectors according to local safety codes and standards and according to the specifications provided by the connector manufacturer. You are responsible for verifying safety compliance of third-party connectors and their usage according to the relevant standard(s), including UL and CSA in North America and IEC and VDE in Europe.

The module comes with one mating connector and backshell kit. Replacement fuses and additional mating connectors are available through general electronics catalogs.

Table 1. Third-Party Accessories for the NI SCXI-1167

Accessory	Rating	Manufacturer and Part Number
5 V internal supply fuse	F2 A, 125 V	Littlefuse, NANO ² , 154.002
78-pin D-subminiature, female, vertical or right-angle	60 V, 5 A	Any

How to Replace the Fuse

The front panel LED shows the status of the +5 V fuse. If the LED is on, the fuse is intact. To replace a fuse, refer to Figure 1 as you complete the following steps:

1. Ground yourself with a grounding strap or with a ground connected to your SCXI chassis. Proper grounding prevents damage to your SCXI module from electrostatic discharge.
2. Power off the SCXI chassis, and remove the module with the blown fuse.
3. Remove the grounding screw of the top cover.
4. Snap out the top cover of the shield by placing a screwdriver in the groove at the bottom of the module and pushing down on the screwdriver to lift out the fuse.
5. Replace the blown fuse. Refer to Figure 2 for the fuse location.
6. Reinstall the top cover and grounding screw.

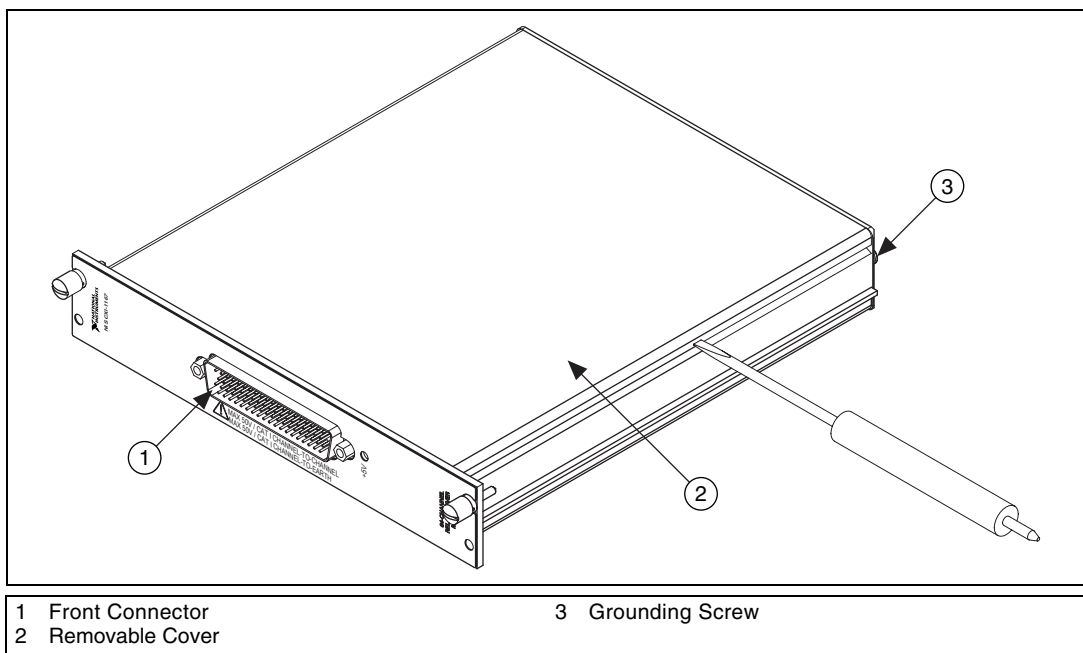

Figure 1. Removing the SCXI Module Cover

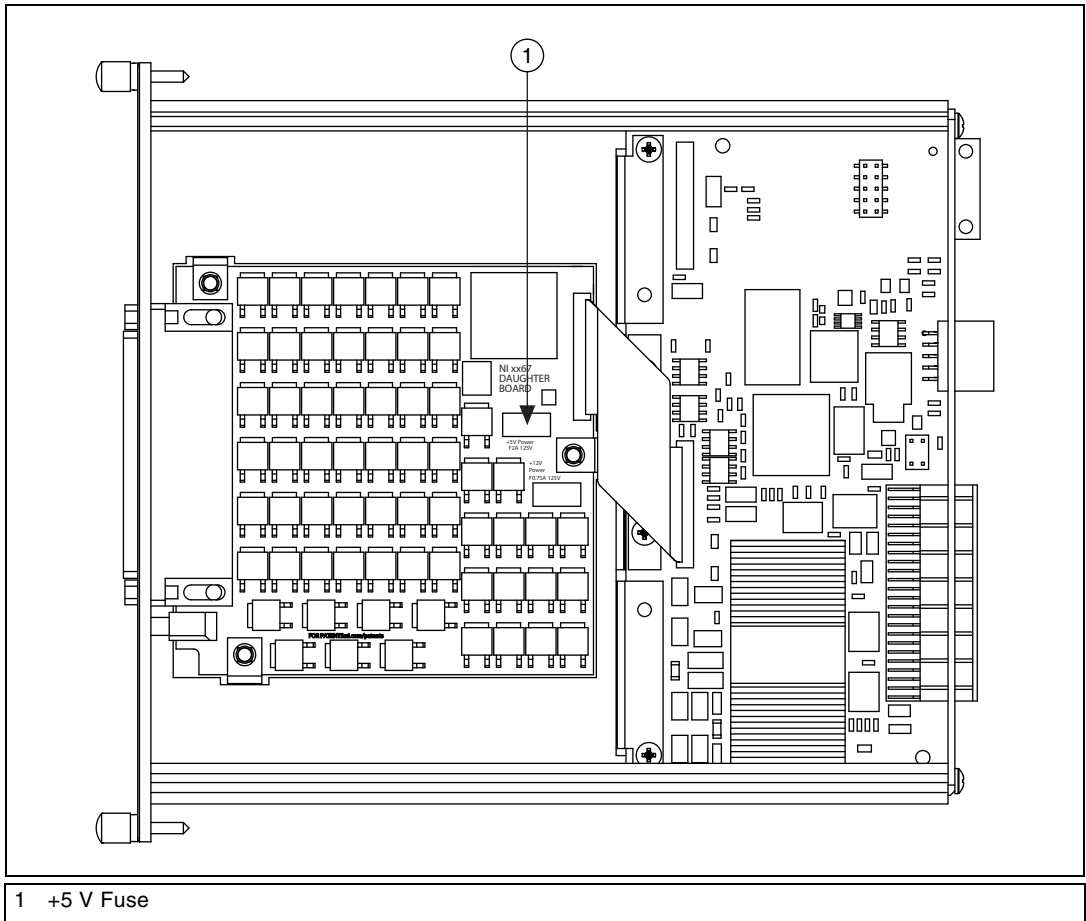

Figure 2. NI SCXI-1167 Daughterboard Diagram with Fuse Location



Note The +12 V fuse is not used on the SCXI-1167, is only rated for 0.75 A, and should not be used as a replacement for the +5 V fuse.

Compliance and Certifications

Safety

This product meets the requirements of the following standards for safety and electrical equipment for measurement, control, and laboratory use:

- IEC 61010-1, EN 61010-1
- UL 3111-1, UL 61010B-1
- CAN/CSA C22.2 No. 1010.1



Note For UL and other safety certifications, refer to the product label, or visit ni.com/hardref.nsf, search by model number or product line, and click the appropriate link in the Certification column.

Electromagnetic Compatibility

EmissionsEN 55011 Class A at 10 m
FCC Part 15A above 1 GHz

ImmunityEN 61326:1997 + A2:2001,
Table 1

EMC/EMICE, C-Tick, and FCC Part 15
(Class A) Compliant



Note For EMC compliance, you *must* operate this device with shielded cabling.

CE Compliance

This product meets the essential requirements of applicable European Directives, as amended for CE marking, as follows:

Low-Voltage Directive (safety).....73/23/EEC

Electromagnetic Compatibility
Directive (EMC)89/336/EEC



Note Refer to the Declaration of Conformity (DoC) for this product for any additional regulatory compliance information. To obtain the DoC for this product, visit ni.com/hardref.nsf, search by model number or product line, and click the appropriate link in the Certification column.

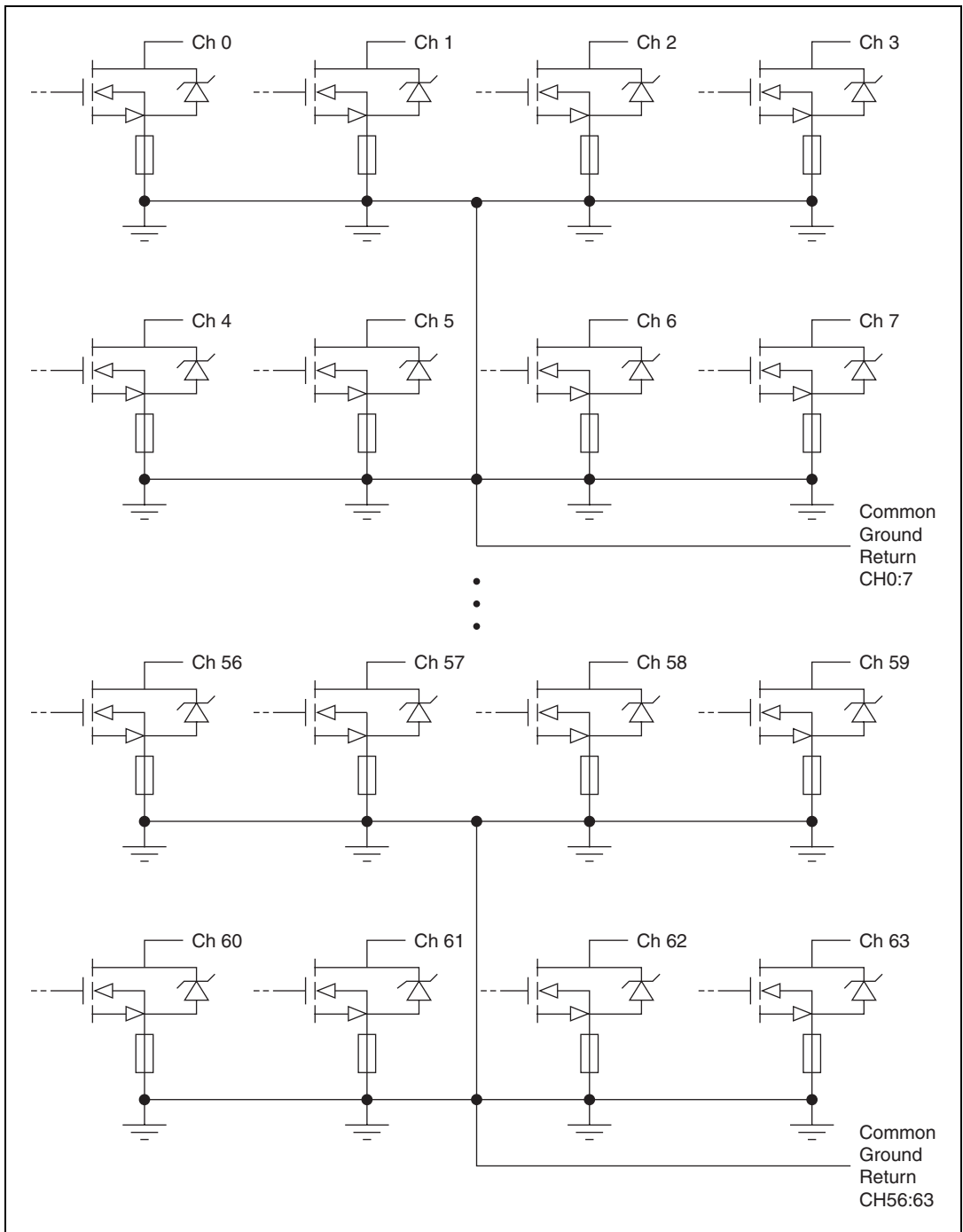

Figure 3. SCXI-1167 Relay Driver Output Topology

