

# NI SCXI™-1127 Specifications

## 32-Channel Relay Multiplexer/Matrix

This document lists specifications for the NI SCXI-1127 multiplexer/matrix module. All specifications are subject to change without notice. Visit [ni.com/manuals](http://ni.com/manuals) for the most current specifications.

Configurations.....	64 × 1, 1-wire multiplexer
	32 × 1, 2-wire multiplexer
	16 × 1, 4-wire multiplexer
	4 × 8, 2-wire matrix

## Input Characteristics

---

All input characteristics are DC, AC<sub>rms</sub>, or a combination unless otherwise specified.

Maximum switching voltage

Channel-to-ground ..... 300 V, CAT II



**Caution** This module is rated for Measurement Category II and intended to carry signal voltages no greater than 300 V. This module features 2300 V<sub>rms</sub> isolation between input signals and the backplane as verified by a dielectric withstand test, 1 minute maximum. Do *not* use this module for connection to signals or for measurements within Categories III or IV. Refer to the *Read Me First: Safety and Radio-Frequency Interference* document for more information about measurement categories.

Modules that can connect to a common high-voltage analog backplane derate to their lowest common voltage rating. Refer to the *NI Switches Getting Started Guide* for more information.

When hazardous voltages ( $>42.4 V_{pk}/60$  VDC) are present on any relay terminal, safety low-voltage ( $\leq 42.4 V_{pk}/60$  VDC) cannot be connected to any other relay terminal.



**Caution** The switching power is limited by the maximum switching current, the maximum voltage, and must not exceed 30 W, 60 VA.

Maximum switching power .....30 W, 60 VA  
(per channel)

Maximum switching current.....1 A  
(per channel)

Maximum carry current .....2 A  
(per channel)

Simultaneous channels  
at maximum carry current.....Up to 4

Minimum switching capacity .....10  $\mu$ A at 10 mVDC

DC path resistance

Initial.....<2  $\Omega$

End of life .....>4  $\Omega$

DC path resistance typically remains low for the life of the relay. At the end of relay life, the path resistance rises rapidly above 2  $\Omega$ . Load ratings apply to relays used within the specification before the end of relay life.

Thermal EMF (differential) .....<3  $\mu$ V

## RF Performance Characteristics

---

Typical bandwidth ..... $\geq$ 11 MHz  
(50  $\Omega$  termination)

Typical channel-to-channel isolation  
(50  $\Omega$  termination)

10 kHz .....>70 dB

100 kHz .....>55 dB

1 MHz.....>50 dB

5 MHz.....>40 dB

10 MHz.....>25 dB

## Dynamic Characteristics

---

Maximum scan rate .....	100 channels/s
Relay operate time (at 20 °C).....	3 ms typical, 5 ms maximum
Release time (at 20 °C) .....	1.5 ms typical, 5 ms maximum
Expected relay life	
Mechanical.....	$5 \times 10^7$ cycles
Electrical	
30 V, 1 A .....	$2 \times 10^5$ cycles
250 V, 200 $\mu$ A .....	$1 \times 10^5$ cycles
250 V, 200 mA .....	$5 \times 10^4$ cycles

## Trigger Characteristics

---

Input trigger	
Sources .....	SCXI trigger line 0, Rear connector, Front panel
Minimum pulse width .....	500 ns
Scanner advanced trigger	
Destinations .....	SCXI trigger line 2, Front panel
Pulse width.....	1.1 $\mu$ s

## Physical Characteristics

---

Relay types .....	Electromechanical, non-latching
Relay contact material.....	Gold-clad silver alloy
Dimensions (W $\times$ H $\times$ D).....	$3.0 \times 17.3 \times 19.8$ cm ( $1.2 \times 6.8 \times 7.8$ in.)
Weight.....	680 g (1 lb 8 oz)

## Environment

The NI SCXI-1127 is intended for indoor use only.

Operating temperature .....0 °C to 50 °C

Storage temperature .....–20 °C to 70 °C

Relative humidity .....5% to 85%, noncondensing

Recommended warm-up time.....5 minutes

Pollution Degree .....2

Approved at altitudes up to 2,000 m.

## Accessories

Visit [ni.com](http://ni.com) for more information about the following accessories.

**Table 1.** Accessories Available for the NI SCXI-1127

Accessory	Part Number
NI SCXI-1331 terminal block (64 × 1, 1-wire multiplexer) (32 × 1, 2-wire multiplexer) (16 × 1, 4-wire multiplexer)	777687-31
NI SCXI-1332 terminal block (4 × 8, 2-wire matrix)	777687-32
0.40 m matrix expansion cable	185440-0R4
0.75 m matrix expansion cable	185440-0R75

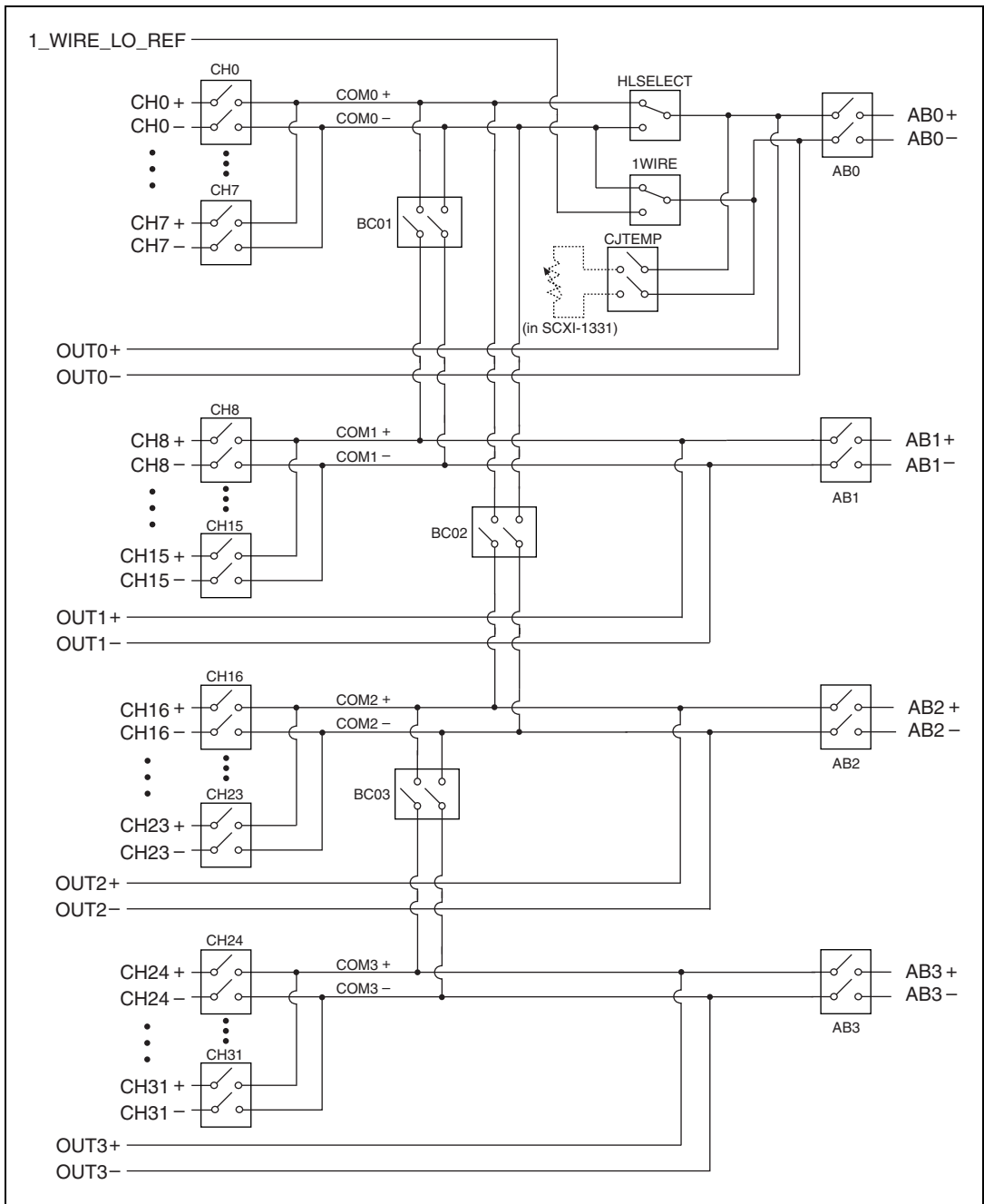

**Figure 1.** NI SCXI-1127 Power-On State

# Compliance and Certifications

---

## Safety

This product is designed to meet the requirements of the following standards of safety for electrical equipment for measurement, control, and laboratory use:

- IEC 61010-1, EN 61010-1
- UL 61010-1
- CAN/CSA-C22.2 No. 61010-1



**Note** For UL and other safety certifications, refer to the product label or visit [ni.com/certification](http://ni.com/certification), search by model or product line, and click the appropriate link in the Certification column.

## Electromagnetic Compatibility

Emissions .....EN 55011 Class A at 10 m  
FCC Part 15A above 1 GHz

Immunity .....EN 61326:1997 + A2:2001,  
Table 1

CE, C-Tick, and FCC Part 15 (Class A) Compliant



**Note** For EMC compliance, operate this device with shielded cabling.

## CE Compliance

This product meets the essential requirements of applicable European Directives, as amended for CE marking, as follows:

Low-Voltage Directive (safety).....73/23/EEC

Electromagnetic Compatibility  
Directive (EMC) .....89/336/EEC



**Note** Refer to the Declaration of Conformity (DoC) for this product for any additional regulatory compliance information. To obtain the DoC for this product, visit [ni.com/certification](http://ni.com/certification), search by model number or product line, and click the appropriate link in the Certification column.

National Instruments, NI, ni.com, and LabVIEW are trademarks of National Instruments Corporation. Refer to the *Terms of Use* section on [ni.com/legal](http://ni.com/legal) for more information about National Instruments trademarks. Other product and company names mentioned herein are trademarks or trade names of their respective companies. For patents covering National Instruments products, refer to the appropriate location: **Help»Patents** in your software, the `patents.txt` file on your CD, or [ni.com/patents](http://ni.com/patents).