

# NI PXI-2566 Specifications

## 16-Channel SPDT Relay Module

This document lists specifications for the NI PXI-2566 general purpose relay module. All specifications are subject to change without notice. Visit [ni.com/manuals](http://ni.com/manuals) for the most current specifications.

Configuration ..... 16-channel SPDT, nonlatching

## Input Characteristics

---

Maximum switching voltage

Channel-to-channel ..... 150 VDC, 125 VAC

Channel-to-ground ..... 150 VDC, 125 VAC, CAT I



**Caution** This module is rated for Measurement Category I and intended to carry signal voltages no greater than 150 V. This module can withstand up to 800 V impulse voltage. Do *not* use this module for connection to signals or for measurements within Categories II, III, or IV. Do *not* connect to MAINS supply circuits (for example, wall outlets) of 115 or 230 VAC. Refer to the *NI Switches Getting Started Guide* for more information on measurement categories.

When hazardous voltages ( $>42.4 V_{pk}/60$  VDC) are present on any relay terminal, safety low voltage ( $<42.4 V_{pk}/60$  VDC) cannot be connected to any other relay terminal.

Maximum switching power ..... 60 W, 62.5 VA (DC to 60 Hz)  
(per channel, not to exceed 2 A per channel)

Maximum switching current ..... 2 ADC, 2 AAC  
(per channel)

Simultaneous channels at maximum  
switching current ( $\leq 25$  °C) ..... 16

Maximum carry current ..... 5 ADC, 5 AAC  
(per channel)

Simultaneous channels at maximum  
carry current ( $\leq 25$  °C) ..... 9

## Module Load Derating at >25 °C

Load derating is dependent on the ambient temperature and the sum of the current squared of each channel simultaneously carrying a signal. The result must fall within the shaded region of Figure 1. The following examples represent this calculation.

Example 1:

5 channels carry 4 A while  
10 channels carry 2 A

$$(5 \times 4^2) + (10 \times 2^2) = 120 \text{ A}$$

Example 1 can be used at ambient temperatures between 0 °C and 50 °C.

Example 2:

6 channels carry 5 A while  
10 channels carry 2 A

$$(6 \times 5^2) + (10 \times 2^2) = 190 \text{ A}$$

Example 2 can be used at ambient temperatures between 0 °C and 41 °C.

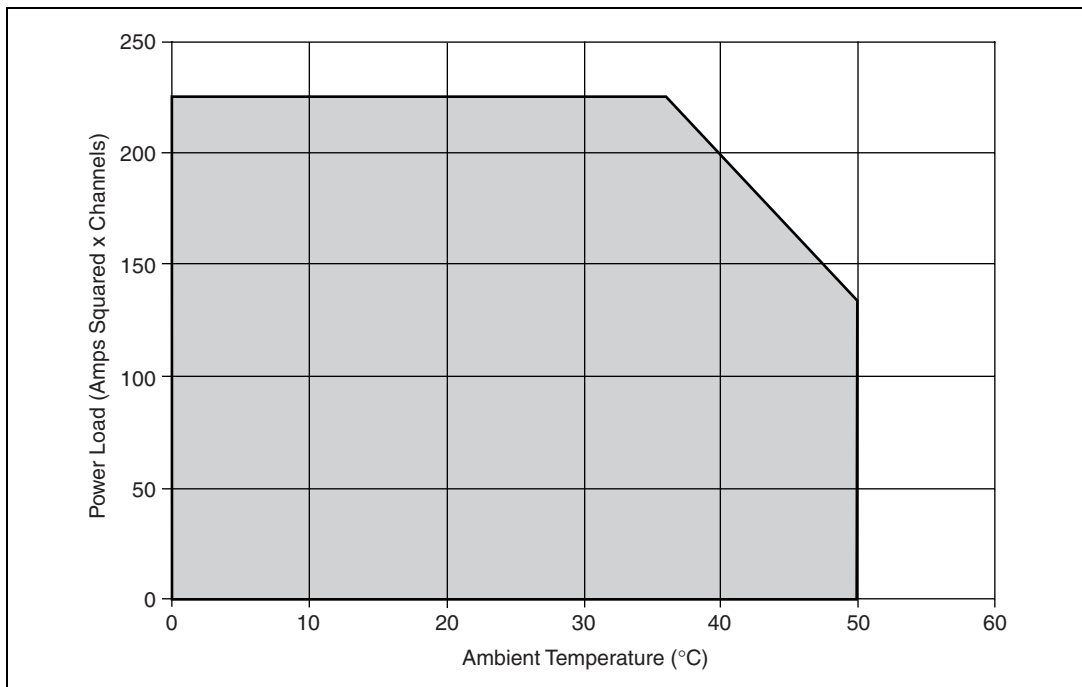

Figure 1. Module Load Derating

DC path resistance

Initial .....  $<0.1 \Omega$

End of life .....  $\geq 1.0 \Omega$

DC path resistance typically remains low for the life of the relay. At the end of relay life, the path resistance rapidly rises above  $1 \Omega$ . Load ratings apply to relays used within the specification before the end of relay life.

Thermal EMF .....  $<9 \mu\text{V}$  (typical at  $23^\circ\text{C}$ )

Minimum switching capacity .....  $10 \mu\text{A}$  at  $10 \text{ mV DC}$

Bandwidth ( $-3 \text{ dB}$ ) .....  $\geq 70 \text{ MHz}$

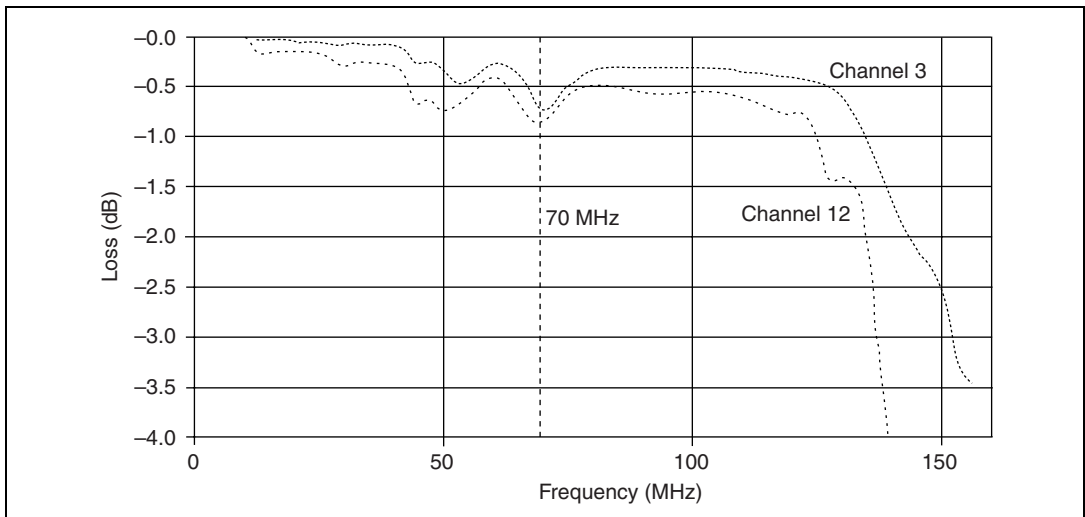

**Figure 2.** Insertion Loss Measured in a  $50 \Omega$  System (Worst Case, Based on 30 Engineering DUTs)

Crosstalk (typical at 23 °C)

Channel-to-channel

10 kHz .....	≤-75 dB
100 kHz .....	≤-65 dB
1 MHz.....	≤-45 dB
10 MHz.....	≤-25 dB

Isolation (typical at 23 °C)

Open channel

100 kHz .....	≥65 dB
1 MHz.....	≥45 dB
10 MHz.....	≥25 dB

## Dynamic Characteristics

---

Maximum cycle speed .....115 cycles/s

Relay operate time

Typical.....	2 ms
Maximum .....	4.4 ms

Expected relay life

Mechanical .....100,000,000 cycles

Electrical

30 VDC, 1 ADC resistive.....	500,000 cycles
30 VDC, 2 ADC resistive.....	100,000 cycles
125 VAC, 0.2 AAC resistive....	300,000 cycles
125 VAC, 0.5 AAC resistive....	100,000 cycles

# Trigger Characteristics

---

## Input trigger

Sources ..... PXI trigger lines 0–7,  
Front panel

Minimum pulse width ..... 150 ns

## Front panel/terminal block input voltage

Minimum ..... –0.5 V

VL maximum ..... +0.7 V

VH minimum ..... +2.0 V

Nominal ..... +3.3 V

Maximum ..... +5.5 V

## Output trigger

Destinations ..... PXI trigger lines 0–7,  
Front panel

Pulse width ..... Programmable (1  $\mu$ s to 62  $\mu$ s)

Front panel nominal voltage ..... 3.3 V TTL, 8 mA

# Physical Characteristics

---

Relay type ..... Electromechanical, nonlatching

Relay contact material ..... Gold-clad silver alloy

I/O connectors ..... Two 62-pin D-SUB connectors

PXI power requirement ..... 4.5 W at 5 V  
2.5 W at 3.3 V

Dimensions (W  $\times$  H  $\times$  D) ..... 2.0 cm  $\times$  10.0 cm  $\times$  16.3 cm  
(0.8 in.  $\times$  3.9 in.  $\times$  6.4 in.)

Weight ..... 250 g  
(9 oz)

## Environment

Operating temperature .....0 °C to 50 °C  
Storage temperature .....–20 °C to 70 °C  
Relative humidity .....5% to 85% noncondensing  
Pollution Degree .....2  
Approved at altitudes up to 2,000 m  
Indoor use only

## Accessories

Visit [ni.com](http://ni.com) for more information about the following accessories.

**Table 1.** Accessories Available for the NI PXI-2566

Accessory	Part Number
NI TB-2666 terminal block	778717-66
Backshell and connector kit	778720-01



**Note** The module and accessory kit connectors are keyed and have pins removed for safety isolation.



**Caution** You *must* install mating connectors according to local safety codes and standards and according to the specifications provided by the connector manufacturer. You are responsible for verifying safety compliance of third-party connectors and their usage according to the relevant standard(s), including UL and CSA in North America and IEC and VDE in Europe.

**Table 2.** Third-Party Accessory for the NI PXI-2566

Accessory	Manufacturer
62-pin D-SUB connector	Any

# Glossary

---

- channel a single-pole, double-throw (SPDT) (form C) relay. Each channel has three terminals—common (COM), normally closed (NC), normally open (NO).
- cycle actuate an SPDT relay twice, leaving it in its original state.
- operate actuate an SPDT relay once, leaving it in the opposite state.

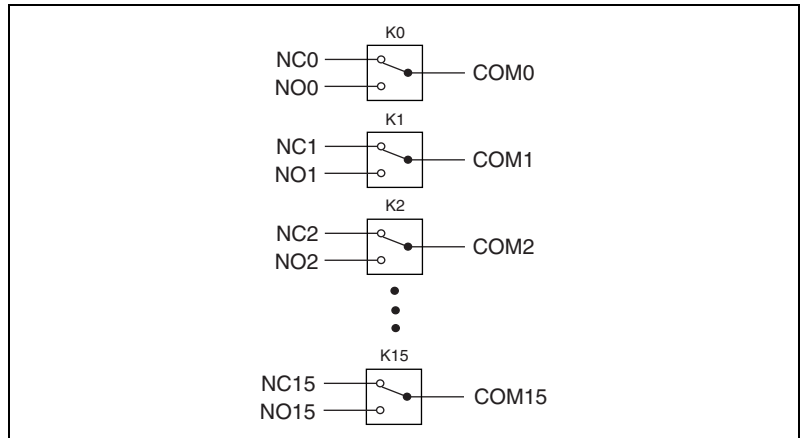

**Figure 3.** NI PXI-2566 Power-On State

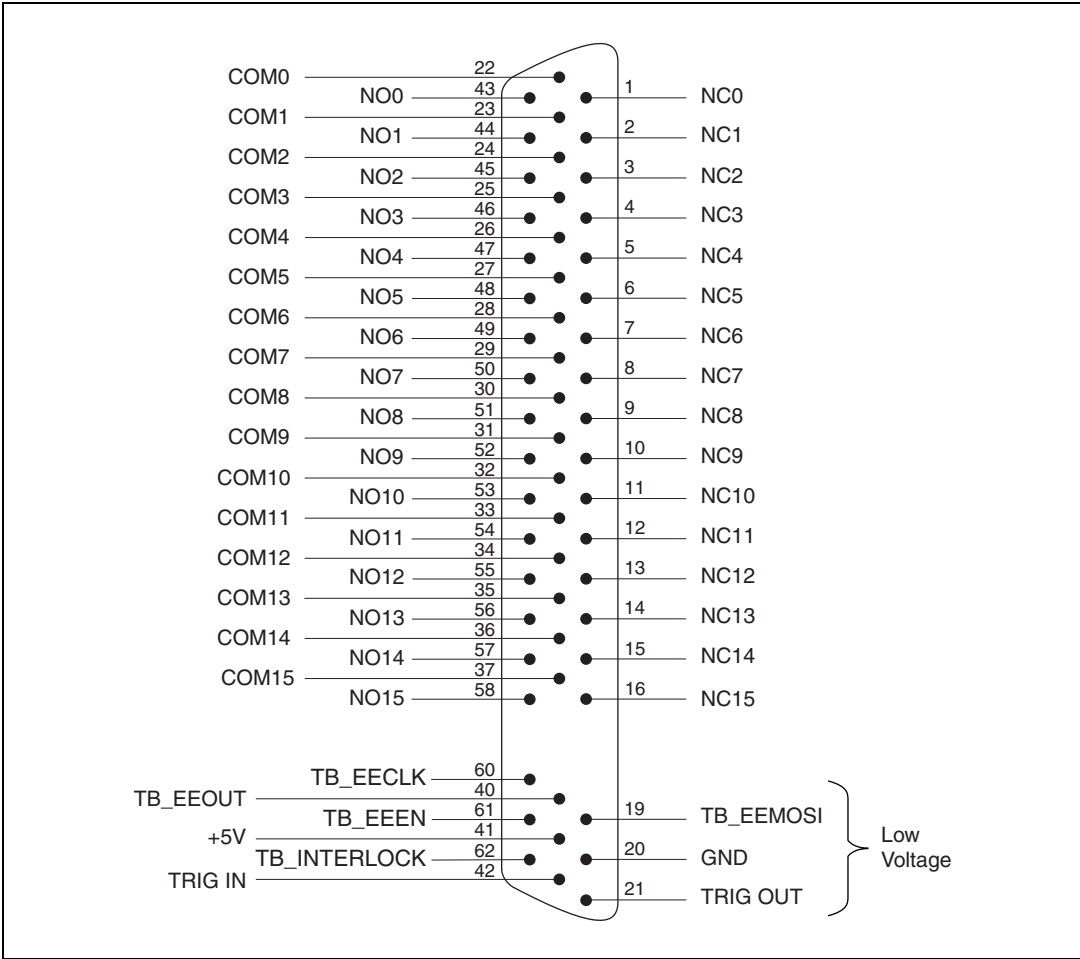

Figure 4. NI PXI-2566 Front Connector

# Compliance and Certifications

---

## Safety

This product meets the requirements of the following standards for safety and electrical equipment for measurement, control, and laboratory use:

- IEC 61010-1, EN 61010-1
- UL 3111-1, UL 61010B-1
- CAN/CSA C22.2 No. 1010.1



**Note** For UL and other safety certifications, refer to the product label, or visit [ni.com/hardref.nsf](http://ni.com/hardref.nsf), search by model number or product line, and click the appropriate link in the Certification column.

## Electromagnetic Compatibility

Emissions .....	EN 55011 Class A at 10 m FCC Part 15A above 1 GHz
Immunity .....	EN 61326:1997 + A2:2001, Table 1
EMC/EMI.....	CE, C-Tick, and FCC Part 15 (Class A) Compliant



**Note** For EMC compliance, you *must* operate this device with shielded cabling.

## CE Compliance

This product meets the essential requirements of applicable European Directives, as amended for CE marking, as follows:

Low-Voltage Directive (safety) .....	73/23/EEC
Electromagnetic Compatibility Directive (EMC) .....	89/336/EEC



**Note** Refer to the Declaration of Conformity (DoC) for this product for any additional regulatory compliance information. To obtain the DoC for this product, visit [ni.com/hardref.nsf](http://ni.com/hardref.nsf), search by model number or product line, and click the appropriate link in the Certification column.

National Instruments™, NI™, and ni.com™ are trademarks of National Instruments Corporation. Product and company names mentioned herein are trademarks or trade names of their respective companies. For patents covering National Instruments products, refer to the appropriate location: **Help» Patents** in your software, the `patents.txt` file on your CD, or [ni.com/patents](http://ni.com/patents).

© 2003 National Instruments Corp. All rights reserved.

373468B-01

Dec03