

NI PXI-2530 Specifications

128-Channel Reed Relay Multiplexer/Matrix

This document lists specifications for the National Instruments PXI-2530 128-channel multiplexer/matrix module.

All specifications are subject to change without notice. Visit ni.com/manuals for the most current specifications.

Configurations.....128 × 1, 1-wire multiplexer; 64 × 1, 2-wire multiplexer; 32 × 1, 4-wire multiplexer;
4 × 32, 1-wire matrix; 8 × 16, 1-wire matrix; 4 × 16, 2-wire matrix



Note The NI PXI-2530 has eight interconnected banks of 16 × 1, 1-wire multiplexers. These multiplexers can be used in any combination with the independent topology.

Input Characteristics

All input characteristics are DC, AC_{rms}, or a combination unless otherwise specified.

Maximum switching voltage

Channel-to-channel 60 VDC, 30 VAC_{rms},
CAT I

Channel-to-ground..... 60 VDC, 30 VAC_{rms},
CAT I

Maximum current 0.4 A
(per terminal or internal path)

Maximum switching power 10 W
(per channel, resistive)

Typical DC path resistance
(channel-to-common)

Initial <2 Ω

End of life..... ≥3 Ω

Path resistance is a combination of relay contact resistance and trace resistance. Contact resistance typically remains low for the life of a relay. At the end of relay life, the contact resistance may rapidly rise above 1 Ω.

Typical thermal EMF..... <50 μV
(1-wire configuration, channel-to-common)

RF Performance Characteristics

Typical bandwidth
(50 Ω system, 1-wire configuration referenced to 1WREF)

16 × 1..... >15 MHz

128 × 1..... >3 MHz

Typical channel-to-channel isolation

(50 Ω system, 1-wire configuration referenced to 1WREF)

200 kHz..... >60 dB

1 MHz >40 dB

Dynamic Characteristics

Maximum scan rate 900 channels/s

Simultaneous drive limit 64 relays

Typical relay life

Mechanical..... 1,000,000,000 cycles

Electrical (resistive)

10 V, 100 mA 100,000,000 cycles

25 V, 400 mA 5,000,000 cycles

60 V, 160 mA 1,000,000 cycles



Note Reed relays are highly susceptible to damage from in-rush currents. Switching capacitive loads without resistive or inductive protection may weld the relay contacts in less than 1,000,000 cycles.

Trigger Characteristics

Input trigger

Sources..... PXI trigger lines 0–7,
Front panel

Minimum pulse width..... 150 ns

Front panel input voltage

Minimum –0.5 V

V_{IL} maximum +0.7 V

V_{IH} minimum..... +2.0 V

Nominal+3.3 V
 Maximum+5.5 V



Note The NI PXI-2530 can recognize trigger pulse widths that are less than 150 ns by disabling digital filtering. For information about disabling digital filtering, refer to the *NI Switches Help*.

Output trigger

DestinationsPXI trigger lines 0–7,
 Front panel
 Pulse width.....Programmable
 (1 μ s to 62 μ s)
 Front panel nominal voltage+3.3 V TTL, 8 mA

Physical Characteristics

Relay typesReed



Note NI advises against installing reed relay modules directly adjacent to an embedded controller with a magnetic hard drive because of the sensitivity of reed relays and the possibility of interference from magnetic hard drives.

Contact materialRhodium
 Front panel connector176-pin docking station
 plug
 Dimensions (W \times H \times D)Single PXI slot, 3U
 2.0 cm \times 10.0 cm \times
 17.5 cm
 (0.8 in. \times 3.9 in. \times 6.9 in.)
 Weight400 g (14 oz)

Environment

Operating temperature.....0 $^{\circ}$ C to 55 $^{\circ}$ C
 Storage temperature.....–20 $^{\circ}$ C to 70 $^{\circ}$ C
 Relative humidity5% to 85%
 noncondensing
 Pollution Degree.....2
 Approved at altitudes up to 2,000 m.
 Indoor use only.

Shock and Vibration

Operational shock 30 g peak, half-sine,
 11 ms pulse (Tested
 in accordance with
 IEC-60068-2-27. Test
 profile developed in
 accordance with
 MIL-PRF-28800F.)

Random vibration

Operating 5 to 500 Hz, 0.3 g_{rms}
 Nonoperating 5 to 500 Hz, 2.4 g_{rms}
 (Tested in accordance
 with IEC-60068-2-64.
 Nonoperating test profile
 exceeds the requirements
 of MIL-PRF-28800F,
 Class 3.)

Accessories

Visit ni.com for more information about the following accessories.

Table 1. Accessories Available for the NI PXI-2530

Accessory	Part Number
NI TB-2630 Terminal Block (multiplexer)	778733-01
NI TB-2631 Terminal Block (4 \times 32, 1-wire matrix, 4 \times 16, 2-wire matrix)	778734-01
NI TB-2632 Terminal Block (8 \times 16, 1-wire matrix)	778735-01



Caution You *must* install mating connectors according to local safety codes and standards and according to the specifications provided by the connector manufacturer. You are responsible for verifying safety compliance of third-party connectors and their usage according to the relevant standard(s), including UL and CSA in North America and IEC and VDE in Europe.

Table 2. Third-Party Accessories for the NI PXI-2530

Accessory	Manufacturer	Manufacturer Part Number
Mating front panel connector, right-angle	Molex	52755-1760

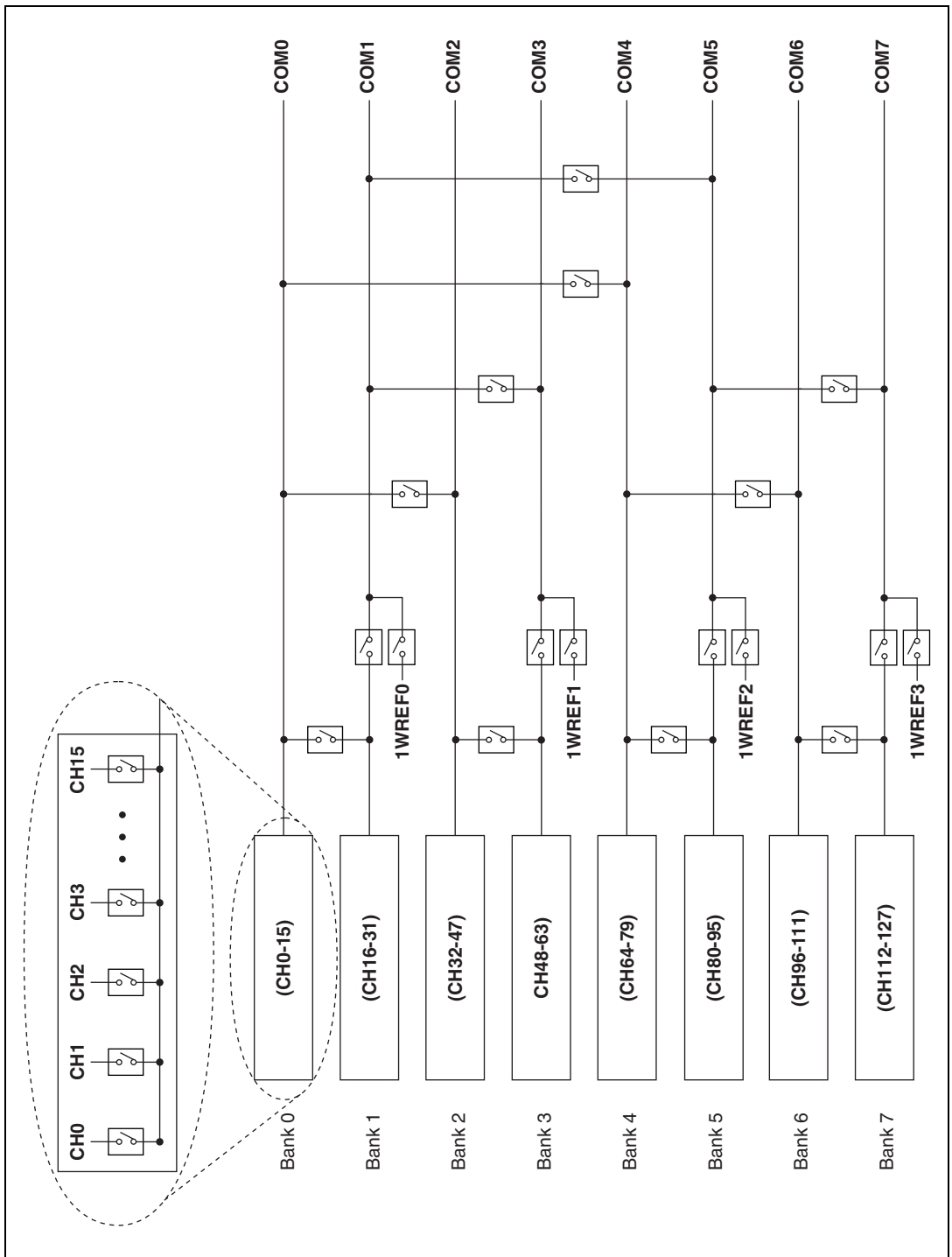

Figure 1. NI PXI-2530 Power-On State (All Relays Open)

Compliance and Certifications

Safety

This product is designed to meet the requirements of the following standards of safety for electrical equipment for measurement, control, and laboratory use:

- IEC 61010-1, EN 61010-1
- UL 3111-1, UL 61010B-1
- CAN/CSA-C22.2 No. 1010-1



Note For UL and other safety certifications, refer to the product label or visit ni.com/certification, search by model number or product line, and click the appropriate link in the Certification column.

Electromagnetic Compatibility

Emissions.....EN 55011 Class A at 10 m
FCC Part 15A above
1 GHz

ImmunityEN 61326:1997 +
A2:2001, Table 1

CE, C-Tick, and FCC Part 15 (Class A) Compliant



Note For EMC compliance, you *must* operate this device with shielded cabling.

CE Compliance

This product meets the essential requirements of applicable European Directives, as amended for CE marking, as follows:

Low-Voltage Directive (safety).....73/23/EEC

Electromagnetic Compatibility

Directive (EMC).....89/336/EEC



Note Refer to the Declaration of Conformity (DoC) for this product for any additional regulatory compliance information. To obtain the DoC for this product, visit ni.com/certification, search by model number or product line, and click the appropriate link in the Certification column.

National Instruments, NI, ni.com, and LabVIEW are trademarks of National Instruments Corporation. Refer to the *Terms of Use* section on ni.com/legal for more information about National Instruments trademarks. Other product and company names mentioned herein are trademarks or trade names of their respective companies. For patents covering National Instruments products, refer to the appropriate location: **Help»Patents** in your software, the `patents.txt` file on your CD, or ni.com/patents.