

GETTING STARTED GUIDE

National Instruments™ Switch Executive

National Instruments Switch Executive is one component of NI test management software, that includes LabVIEW, Measurement Studio, TestStand, and IVI. For validation test and research and development test, NI Switch Executive works with LabVIEW and LabWindows™/CVI™ to develop and change systems faster. For production test, NI Switch Executive integrates with TestStand to give test step ease-of-use in sequence execution.

Contents

Overview	2
Getting Started	2
Installing the Software	3
Installing the Hardware	3
Tutorial: Configure an NI Switch Executive Virtual Device	3
Create an NI Switch Executive Virtual Device	5
Name Your Channels	5
Batch Rename Channels	6
Create Mutual Exclusions	6
Create Set Exclusions	6
Create Buses	7
Create Routes	7
Create Route Groups	8
Organize Tests with Route Groups	8
Use Route Groups within Route Groups	9
Validate the NI Switch Executive Virtual Device	10
Programming NI Switch Executive	10
Configuring an NI Switch Executive Virtual Device	11
Using TestStand with NI Switch Executive	11
Where to Go for Support	13

Overview

NI Switch Executive is a configuration tool designed to simplify the management and control of switching systems. With NI Switch Executive, you can do the following tasks:

- Develop multiple-device switch systems represented as a single virtual device
- Create end-to-end signal routing
- Route selections based on signal characteristics and switch capabilities
- Create switch routing for end to-end calibration and maximum execution speed
- Create aliases for channels
- Preconfigure routes and route groups that can be called by name at run time
- Control NI and third-party switches
- Integrate seamlessly with TestStand for automated test systems



Note This document provides introductory information about NI Switch Executive. For more information about using NI Switch Executive, select **National Instruments»NI Switch Executive»NI Switch Executive Help** from the Start menu.

Getting Started

Make sure you have the following items:

- A development or evaluation license for NI Switch Executive
- Measurement & Automation Explorer (MAX) 3.1 or later
- An application development environment (ADE) such as LabVIEW or Measurement Studio
- Windows 2000/XP
- Interchangeable Virtual Instruments (IVI-compliant) switches or a simulated IVI switch
- Installed IVI instrument drivers for your physical switches
- (Optional) TestStand test management software

Installing the Software

Complete the following steps to install NI Switch Executive:



Note If you are using NI switches, install NI-SWITCH 2.2 or later *before* using them with NI Switch Executive.

1. Install your ADE, such as LabVIEW or Measurement Studio, or install TestStand test management software.
2. Insert the NI Switch Executive CD into your CD drive to launch the installation wizard.



Note If the installation wizard does not appear, navigate to your CD drive and run `autorun.exe`.

3. Click **Install NI Switch Executive**, and complete the installation wizard.

Installing the Hardware

NI Switch Executive uses IVI to access both NI and third-party switch devices. For NI switches, install and configure the devices using the *NI Switches Getting Started Guide*.



Note NI Switch Executive automatically creates logical names and other required IVI configuration information for any detected National Instruments switch products.

For third-party switches, install and configure them as specified in the manufacturer-supplied documentation. You must then manually create IVI configuration for these devices using the IVI Drivers section in MAX. Refer to **Configuration»IVI Switches** in the *NI Switch Executive Help* for more information.

Tutorial: Configure an NI Switch Executive Virtual Device

An NI Switch Executive virtual device contains the configuration information about a switching system. This information includes definitions and configurations for the switches, channels, hardwires, buses, exclusions, routes, and route groups associated with your switching configuration. After you have configured an NI Switch Executive virtual device in MAX, you can control your system with this configuration using an ADE.

To acquaint you with the fundamentals of using NI Switch Executive, this tutorial creates an NI Switch Executive virtual device using two 8×8 matrices that operate as one 8×16 matrix. The architecture for the switch system you are creating for this tutorial is shown in Figure 1.

This tutorial recreates the `SwitchExecutiveExample` that appears under **Devices and Interfaces»NI Switch Executive Virtual Devices** in MAX.

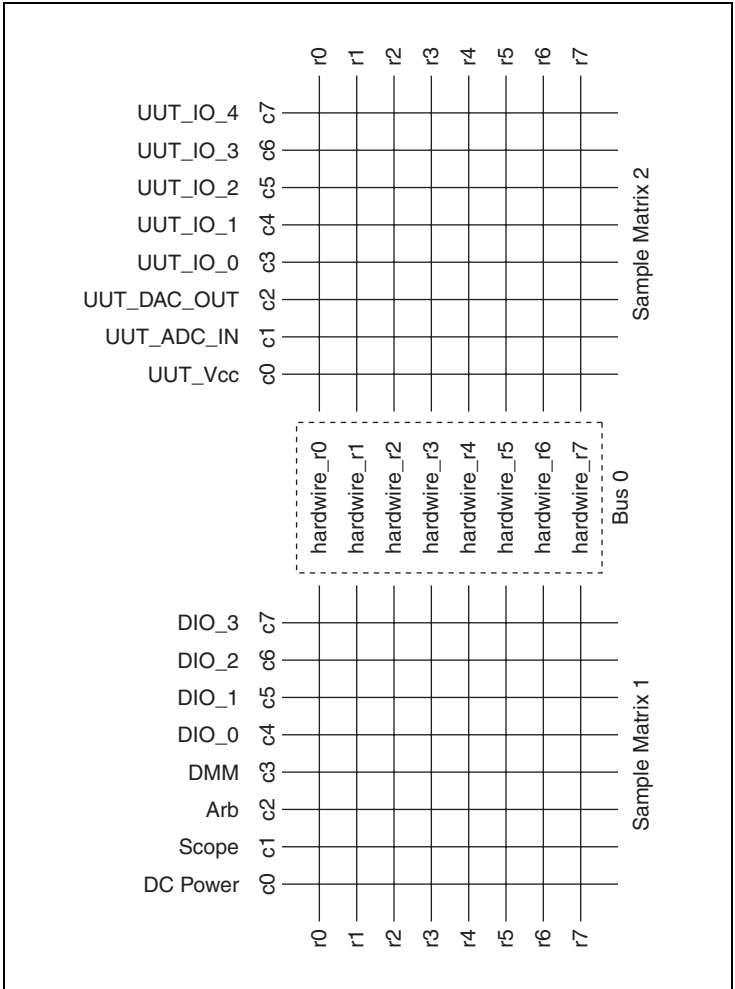

Figure 1. Example Switch System Layout

Create an NI Switch Executive Virtual Device

The NI Switch Executive configuration tools are embedded within MAX. To create an NI Switch Executive virtual device, complete the following steps:

1. Launch MAX.
2. Expand **Devices and Interfaces**.
3. Right-click **NI Switch Executive Virtual Devices**, and select **Create New NI Switch Executive Virtual Device**.
4. On the next dialog box, name your NI Switch Executive virtual device. The name you select is the name used to refer to the virtual device in the API. For this example, name the virtual device `SwitchExecutiveTutorial`.
5. Ensure the **Create new configuration** radio button is selected in the Configuration Mode section.
6. Click **Next**.
7. From the **Available Switches** window, add `SampleMatrix1` and `SampleMatrix2` to the **Switches to Add** window by clicking the right arrow button. These switches are associated with the virtual device.
8. Click **Next**.
9. When configuration is complete, click **Finish**. MAX automatically browses to the new NI Switch Executive virtual device so that you can continue with the virtual device configuration.

Name Your Channels

Now that the NI Switch Executive virtual device has been created, you need to configure the device. To begin, name your channels based on the configuration in Figure 1.

1. Double-click the **c0** channel of `SampleMatrix1` and enter `DCPower` in the **Alias** field. As you configure your system, you can select these channels by their alias.



Tip To reduce the list of displayed channels, you can filter the list using the filter field at the bottom of the column. For example, to list only the columns of the matrices, type `c` in the filter field. Only channels that begin with `c` appear in the list.

2. Repeat for `Scope`, `Arb`, `DMM`, `UUT_Vcc`, `UUT_ADC_IN`, and `UUT_DAC_OUT`. Refer to Figure 1 to determine what columns to rename.

Batch Rename Channels

For channels with a sequential naming scheme (`DIO_0`, `DIO_1`, `DIO_2`, and so on), you can easily rename large numbers of channels. To sequentially rename multiple channels, complete the following steps:

1. For `DIO_0` through `DIO_3`, hold down the <Shift> key and highlight `c4` through `c7` of `SampleMatrix1`.
2. Click **Batch Rename** at the top menu bar. The Batch Rename window appears.
3. In the **Base Name** field, type `DIO_`.
4. Click **IVI Switch** column heading to sort all the rows.
5. In the **Start Index** field, type 0.
6. Click **OK**. Columns `c4` through `c7` have been renamed `DIO_0`, `DIO_1`, and so on.
7. Repeat steps 3 through 5 for `UUT_IO_n` and `c3` through `c7` of `SampleMatrix2`.

Create Mutual Exclusions

In our sample configuration, we never want channels `DCPower`, `Arb`, and `UUT_DAC_OUT` to connect to one another. To prevent their connection, create a *mutual* exclusion. In the Exclusions panel below the Channels panel, complete the following steps to create a mutual exclusion.

1. Click **Add mutual exclusion** in the Name column heading.
2. In the **Available Channels** list, select `DCPower`, `Arb`, and `UUT_DAC_OUT` and move them to the Mutually Excluded Channels list.

Create Set Exclusions

In the sample configuration, we never want `DIO_n` and `UUT_IO_n` to connect to any other channel with an alias. In effect, we have two *sets* of channels that should not be connected—the first set is `DIO_n` and `UUT_IO_n`, and the second set is channels with an alias.

In the Exclusions panel, complete the following steps to create a set exclusion.

1. Click **Add set exclusion** in the Name column heading.
2. Click the **Alias** column heading to sort all the rows.
3. In the Available Channels list, select channels `DIO_n` and `UUT_IO_n` and move them to the Set 1 Channels list.
4. In the Available Channels list, select any remaining channels with an alias and move them to the Set 2 Channels list.

Create Buses

In our sample configuration, we configured hardwires from `r0` through `r7` of `SampleMatrix1` to `r0` through `r7` of `SampleMatrix2`, respectively. In order for NI Switch Executive to make routing decisions that consider these hardwires, you need to add them to the virtual device configuration. Because the hardwires connect a list of sequential channels to another list of sequential channels, you can create a bus, or group, of hardwires.

1. Click the **Hardwires/Buses** tab.
2. In the Buses panel, click **Add Bus** in the Name column heading.
3. Select `SampleMatrix1` from the IVI Switches list.
4. Enable the **Connect to Bus** checkbox.
5. In the Base Channel field, select `r0`.
6. In the End Channel field, select `r7`.
7. Repeat steps 3 through 6 for `SampleMatrix2`.

If you select any of the hardwires under `Bus0`, you can see the associated channels for each hardware. You can break up the bus into individual hardwires by right-clicking the bus and selecting **Convert Bus to Hardwires**, but you cannot add individual hardwires to a bus.

Create Routes

A route is a connection from one channel, row, or column, to another. To create routes, complete the following steps:

1. Click the **Routes/Groups** tab.
2. Click **Create route** in the Name column heading.
3. Name the route `DIO_0ToUUT_IO_0`.
4. In the Endpoint 1 table of the Visual Route Editor, select `DIO_0`.
5. In the Endpoint 2 table, select `UUT_IO_0`. A dialog box presents a list of channels NI Switch Executive must mark as reserved for routing.



Note All intermediate channels between two endpoints must be marked as reserved for routing. Marking a channel as reserved for routing notifies NI Switch Executive that it can use the given channel as needed to complete a route. For example, to connect `c0` to `c1` in the `SampleMatrix1` shown in Figure 1 requires a reserved for routing channel. In this example, `r0`, `r1`, `r2` and so on can all (or each) be a reserved for routing channel.

6. Click **Yes**.
7. In the Routes/Groups tree, right-click route `DIO_0ToUUT_IO_0` and select **Create Copy**.
8. Rename the new route `DIO_1ToUUT_IO_1`.
9. Select `DIO_1` and `UUT_IO_1` in the Endpoint 1 and Endpoint 2 tables, respectively.
10. Repeat steps 7 through 9 for the remaining `DIO_n` to `UUT_IO_n` routes.

Create Route Groups

Notice how all the routes you just created use `SampleMatrix1/r0` and `SampleMatrix2/r0` for routing. Because our sample application requires these routes to be connected at the same time, we would get an error at run time if we tried to connect them at the same time because both routes use the same reserved for routing channel.

Route groups can be used to ensure that multiple routes connected at the same time are not using the same resources. If the routes are associated in the same group, NI Switch Executive notifies you of any resource conflicts and attempts to automatically correct those conflicts. To create a route group from the routes you just created, complete the following steps:

1. Highlight all the `DIO_nToUUT_IO_n` routes.
2. Right-click the highlighted routes and select **Add Route Group»Group From Current Selections**. NI Switch Executive asks if you want to break those routes to find other connections.
3. Click **Yes**. NI Switch Executive configures the routes to use available resources.
4. Rename the route group `DIOToUUT`.

Organize Tests with Route Groups

Route groups can also be useful for categorizing the connections required for a test. For example, in the sample configuration, you may want to perform a frequency response test. To perform the test, you must connect the `Scope` to `UUT_DAC_OUT` and the `Arb` to `UUT_ADC_IN` at the same time.



Note Route groups help NI Switch Executive make more efficient decisions about which resources to use when creating a route. When two or more routes are added to a route group, NI Switch Executive ensures that these routes do not use conflicting resources.

To create the frequency response test, complete the following steps:

1. Create route `ScopeToOutput` that connects `Scope` to `UUT_DAC_OUT`.
2. Create route `ArbToInput` that connects `Arb` to `UUT_ADC_IN`.
3. Highlight `ScopeToOutput` and `ArbToInput`.
4. Right-click the highlighted routes and select **Add Route Group»Group From Current Selections**. NI Switch Executive asks if you want to break to routes to find other connections.
5. Click **Yes**. NI Switch Executive configures the routes within this route group to use available resources.
6. Rename the new route group `FreqResponseTest`.

Use Route Groups within Route Groups

There may be cases in your application where you need to create the same connections for different tests. For example, during the frequency response test you created, you also need to provide power to the UUT and have a DMM monitor voltage on the UUT. For other tests, you must provide power and monitor voltage. In this case, you can create a route group for these connections that can be used in other route groups.

To create the power connections, complete the following steps:

1. Create route `DCPowerToUUT_Vcc` that connects `DCPower` to `UUT_Vcc`.
2. Create route `DMMToUUT_Vcc` that connects `DMM` to `UUT_Vcc`.
3. Highlight `DCPowerToUUT_Vcc` and `DMMToUUT_Vcc`.
4. Right-click the highlighted routes and select **Add Route Group»Group From Current Selections**. NI Switch Executive asks if you want to break those routes to find other connections.
5. Click **Yes**. NI Switch Executive configures the routes within this route group to use available resources.
6. Rename the new route group `PowerUUT`.
7. In the Routes/Groups tree, use your mouse to drag `PowerUUT` and drop it on the route group `FreqResponseTest`. NI Switch Executive asks if you want to break those routes to find other connections.
8. Click **Yes**. NI Switch Executive configures the routes within route group `FreqResponseTest` and within route group `PowerUUT` to use available resources.
9. Create a route group named `FreqRespWithIO`.
10. Drag `FreqResponseTest` and `DIOToUUT` onto the route group `FreqRespWithIO`.

Validate the NI Switch Executive Virtual Device

Before using the NI Switch Executive virtual device, you should validate it. Validating the virtual device ensures that IVI configuration information, routes, and route groups are all valid.



Caution During the validation process, all routes and route groups are connected. When you validate a real system, ensure that all of the equipment is ready to handle switch connections.

To validate your NI Switch Executive virtual device, click **Validate** in the top menu bar.

Programming NI Switch Executive

Figure 2 illustrates a typical NI Switch Executive programming flow.

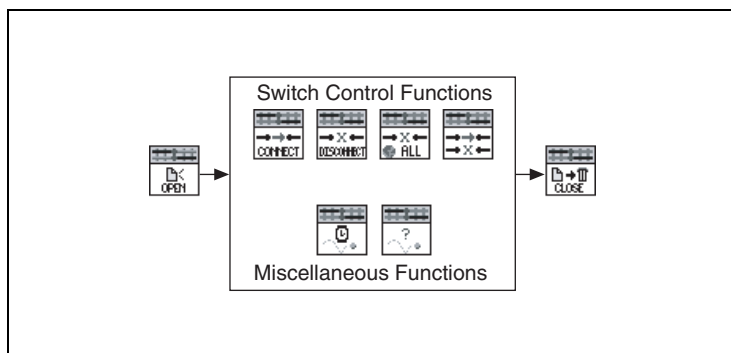

Figure 2. NI Switch Executive Programming Flow

The basic steps required to use an NI Switch Executive virtual device are as follows:

1. Open a session
2. Control the switches
3. Handle errors
4. Close the session

Refer to **Programming»Tutorial** in the *NI Switch Executive Help* for more information about programming.

Configuring an NI Switch Executive Virtual Device

NI Switch Executive provides a programmatic interface to manage your NI Switch Executive virtual device configurations. Use the configuration API to programmatically create and edit switching devices, channels, hardwires, buses, exclusions, routes, and route groups associated with your virtual device.

Refer to **Configuration»Programming** in the *NI Switch Executive Help* for more information about programming.

Using TestStand with NI Switch Executive

TestStand 2.0.1 and later includes a **Switching** tab on the Step Properties dialog box. Use this feature to use your NI Switch Executive virtual device in TestStand.

Use the **Switching** tab to specify the switching action you want TestStand to perform as a step. Figure 3 shows the **Switching** tab in the step properties dialog box.

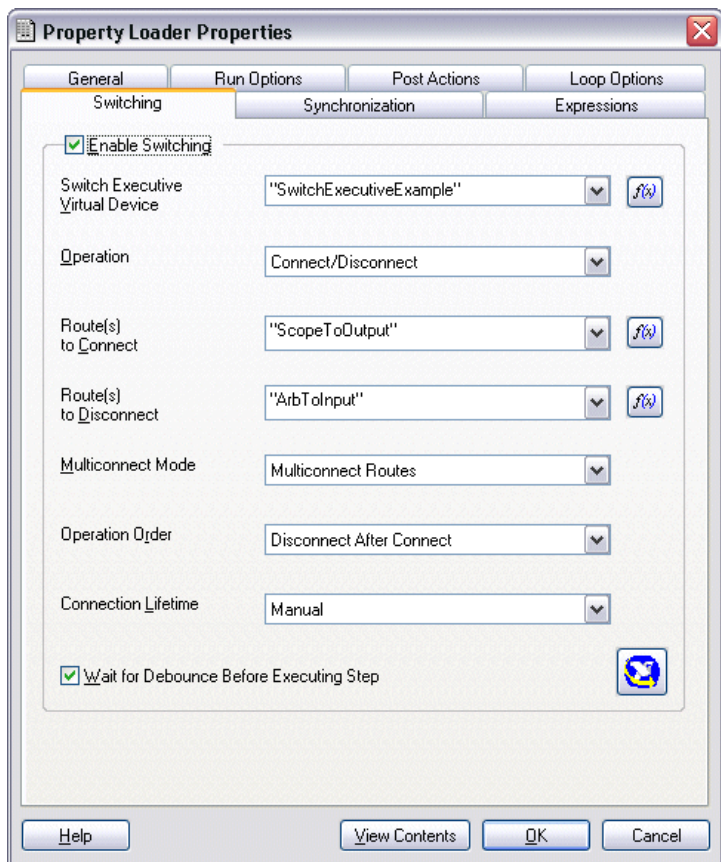

Figure 3. Switching Tab in the TestStand Step Properties Dialog Box

The IVI Switch step type supports not only the IVI class layer but also NI Switch Executive operations.

For general information about TestStand, refer to the TestStand documentation. For specific information about using NI Switch Executive with TestStand, refer to the *NI Switch Executive Help*.

Where to Go for Support

The National Instruments Web site is your complete resource for technical support. At ni.com/support you have access to everything from troubleshooting and application development self-help resources to email and phone assistance from NI Application Engineers.

National Instruments corporate headquarters is located at 11500 North Mopac Expressway, Austin, Texas, 78759-3504. National Instruments also has offices located around the world to help address your support needs. For telephone support in the United States, create your service request at ni.com/support and follow the calling instructions or dial 512 795 8248. For telephone support outside the United States, contact your local branch office:

Australia 1800 300 800, Austria 43 0 662 45 79 90 0,
Belgium 32 0 2 757 00 20, Brazil 55 11 3262 3599, Canada 800 433 3488,
China 86 21 6555 7838, Czech Republic 420 224 235 774,
Denmark 45 45 76 26 00, Finland 385 0 9 725 725 11,
France 33 0 1 48 14 24 24, Germany 49 0 89 741 31 30,
India 91 80 51190000, Israel 972 0 3 6393737, Italy 39 02 413091,
Japan 81 3 5472 2970, Korea 82 02 3451 3400, Lebanon 961 0 1 33 28 28,
Malaysia 1800 887710, Mexico 01 800 010 0793,
Netherlands 31 0 348 433 466, New Zealand 0800 553 322,
Norway 47 0 66 90 76 60, Poland 48 22 3390150,
Portugal 351 210 311 210, Russia 7 095 783 68 51,
Singapore 1800 226 5886, Slovenia 386 3 425 4200,
South Africa 27 0 11 805 8197, Spain 34 91 640 0085,
Sweden 46 0 8 587 895 00, Switzerland 41 56 200 51 51,
Taiwan 886 02 2377 2222, Thailand 662 278 6777,
United Kingdom 44 0 1635 523545

National Instruments, NI, ni.com, and LabVIEW are trademarks of National Instruments Corporation. Refer to the *Terms of Use* section on ni.com/legal for more information about National Instruments trademarks. Other product and company names mentioned herein are trademarks or trade names of their respective companies. For patents covering National Instruments products, refer to the appropriate location: **Help»Patents** in your software, the `patents.txt` file on your CD, or ni.com/patents.

© 2001–2005 National Instruments Corporation. All rights reserved.