

SCXI™ -1384K CUSTOM TERMINAL BLOCK KIT

This guide describes how to assemble your custom terminal block, make signal connections, and install your custom terminal block.

Introduction

The SCXI-1384K custom terminal block installs in front of the SCXI-1129 module. This terminal block allows you to easily turn the SCXI-1129 module into a high-density matrix configuration designed to meet your needs.

You can use the SCXI-1384K custom terminal block with the SCXI-1129 module to create a custom matrix without any extra wiring except for connecting your signals to the rows and columns of the matrix. You can also combine the rows and/or columns to create many different matrix configurations. Refer to Chapter 2, *Using the SCXI-1129*, in the *SCXI-1129 User Manual* for more information.

The SCXI-1384K custom terminal block has solder terminals that provide access to each of the four 4×16 matrixes. Also, connections for scanner advanced and external trigger signals are available.



Note Common matrix terminology describes matrixes by the number of rows by the number of columns they contain. For example, four rows by 16 columns would be written as 4×16 .

Visit ni.com/instruments for information on other switching solutions.

Conventions



The following conventions are used in this guide:

This icon denotes a note, which alerts you to important information.



This icon denotes a caution, which advises you of precautions to take to avoid injury, data loss, or a system crash.

italic

Italic text denotes variables, emphasis, a cross reference, or an introduction to a key concept. This font also denotes text that is a placeholder for a word or value that you must supply.

monospace

Text in this font denotes text or characters that you should enter from the keyboard, sections of code, programming examples, and syntax examples. This font is also used for the proper names of disk drives, paths, directories, programs, subprograms, subroutines, device names, functions, operations, variables, filenames and extensions, and code excerpts.

Getting Started

To assemble and use your SCXI-1384K custom terminal block, you need the following items:

- SCXI-1384K custom terminal block kit
 - Front panel
 - Rear panel
 - Base
 - Two pieces of insulator foam tape
 - Insulator
 - Safety ground lug
 - Upper strain-relief bar
 - Lower strain-relief bar
 - Snap-on top cover
 - Printed circuit board (PCB)
 - 180-position mating connector
 - Two thumbscrews
 - Five #6 sheet metal screws
 - Two 10-32 × 3/4 inch machine screws
 - Two 4-40 × 3/8 inch machine screws
 - Two 4-40 nuts with nylon inserts
 - Front graphical overlay

- This document
- SCXI chassis
- SCXI-1129 module
- SCXI-1129 User Manual*
- Number 1 and 2 Phillips-head screwdrivers
- 1/8 inch slotted head screwdriver
- Long-nose pliers
- 1/4 inch hex driver or wrench
- Wire cutter
- Wire insulation stripper
- Soldering iron
- Solder

Safety Information

The following cautions contain important safety information concerning hazardous voltages.



Cautions Do *not* operate the device in an explosive atmosphere or where there may be flammable gases or fumes.

Keep away from live circuits. Do *not* remove equipment covers or shields unless you are trained to do so. If signal wires are connected to the device, hazardous voltages can exist even when the equipment is turned off. To avoid a shock hazard, do *not* perform procedures involving cover or shield removal unless you are qualified to do so and disconnect all field power prior to removing covers or shields.

Equipment described in this document must be used in an Installation Category I¹ environment according to IEC 60664-1. This category requires local level supply mains-connected installation.

Do *not* operate damaged equipment. The safety protection features built into this device can become impaired if the device becomes damaged in any way. If the device is damaged, power off the device and do *not* use it until service-trained personnel can check its safety.

¹ Category I refers to a signal level such as voltages of an isolation transformer secondary on a PWB.

If necessary, return the device to National Instruments for service and repair to ensure that its safety is not compromised.

Do *not* operate this equipment in a manner that contradicts the information specified in this document. Misuse of this equipment could result in a shock hazard.

Do *not* substitute parts or modify equipment. Because of the danger of introducing additional hazards, do *not* install unauthorized parts or modify the device. Return the device to NI for service and repair to ensure that its safety features are not compromised.

You *must* insulate all of your signal connections to the highest voltage with which the SCXI-1384K custom terminal block can come in contact.

When using the device with high common-mode voltages, you *must* insulate your signal wires for the highest input voltage. NI is *not* liable for any damages or injuries resulting from inadequate signal wire insulation. Use only 26-20 AWG wire with a minimum voltage rating of 150 V and a temperature value of 60 °C for measuring up to 150 V.

When connecting or disconnecting signal lines to the SCXI circuit board, make sure the lines are powered off. Potential differences between the lines and the SCXI ground can create a shock hazard while you connect the lines.

Connections, including power signals to ground and vice versa, that exceed any of the maximum signal ratings on the SCXI device can create a shock or fire hazard, or can damage any or all of the boards connected to the SCXI chassis, the host computer, and the SCXI device. NI is *not* liable for any damages or injuries resulting from incorrect signal connections.

If hazardous voltages ($\geq 30 V_{\text{rms}}$ and $42.4 V_{\text{peak}}$ or 60 VDC) are present, you *must* connect a safety earth-ground wire to the cable safety-ground lug, shown in Figure 6. This complies with safety agency requirements and protects against electric shock when the cable is not connected to the chassis. To connect the safety earth-ground to the safety-ground lug, run an earth-ground wire from the signal source to the cable. NI is *not* liable for any damages or injuries resulting from inadequate safety earth-ground connections.

Do *not* loosen or re-orient the safety-ground lug hardware when connecting the safety-ground wire; to do so reduces the safety isolation between the high voltage and safety ground.

Clean the module and accessories by brushing off light dust with a soft non-metallic brush. Remove other contaminants with a stiff non-metallic brush. The unit *must* be completely dry and free from contaminants before returning it to service. The terminal block *must* be used with a UL-listed SCXI chassis.

Unpacking

Remove the package contents and inspect the terminal block for missing components or for any signs of damage. Notify NI if any of the components appear damaged in any way. Do *not* install a damaged terminal block onto your system.

Assembling Your Custom Terminal Block

To assemble your custom terminal block, complete the following sections.

Assembling the Strain-Relief

To assemble the strain-relief, complete the following:

1. Adhere insulator foam tape to the upper and lower strain-relief bars as shown in Figure 1.
2. Use two 10-32 \times 3/4 inch screws to loosely combine the upper strain-relief bar to the lower strain-relief bar leaving enough space for your signal connections.

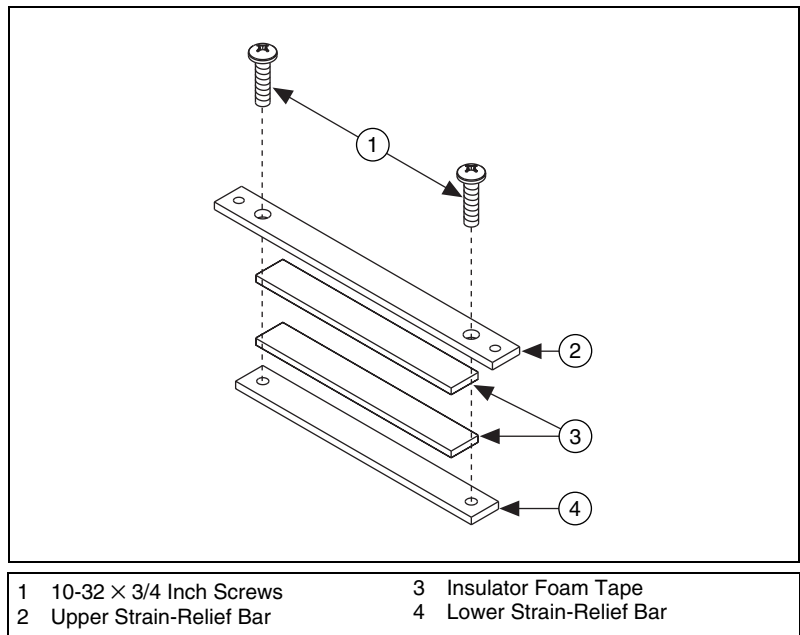
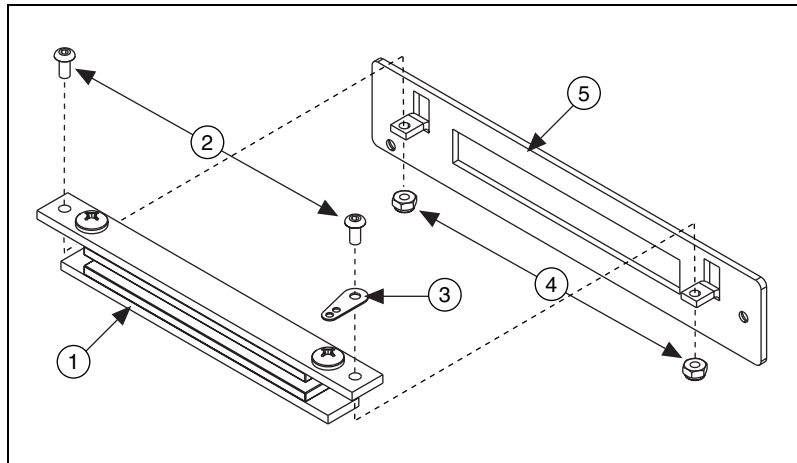

Figure 1. Strain-Relief Parts Locator Diagram

Assembling the Front Panel

To assemble the front panel, complete the following steps:

1. Install the safety ground lug and strain-relief assembly to the front panel using two 4-40 × 3/8 inch screws as shown in Figure 2.
2. Secure the strain-relief assembly to the front panel with two 4-40 nuts.



1 Strain-Relief Assembly	4 4-40 Nuts
2 4-40 × 3/8 Inch Screws	5 Front Panel
3 Safety Ground Lug	

Figure 2. Connecting the Strain-Relief Assembly and Front Panel

Installing the Front Panel

To install the front panel, complete the following steps:

1. Adhere insulator to the base as shown in Figure 3.
2. Attach front panel assembly to base using two #6 sheet metal screws as shown in Figure 3.
3. Adhere front graphical overlay to front panel as shown in Figure 3.

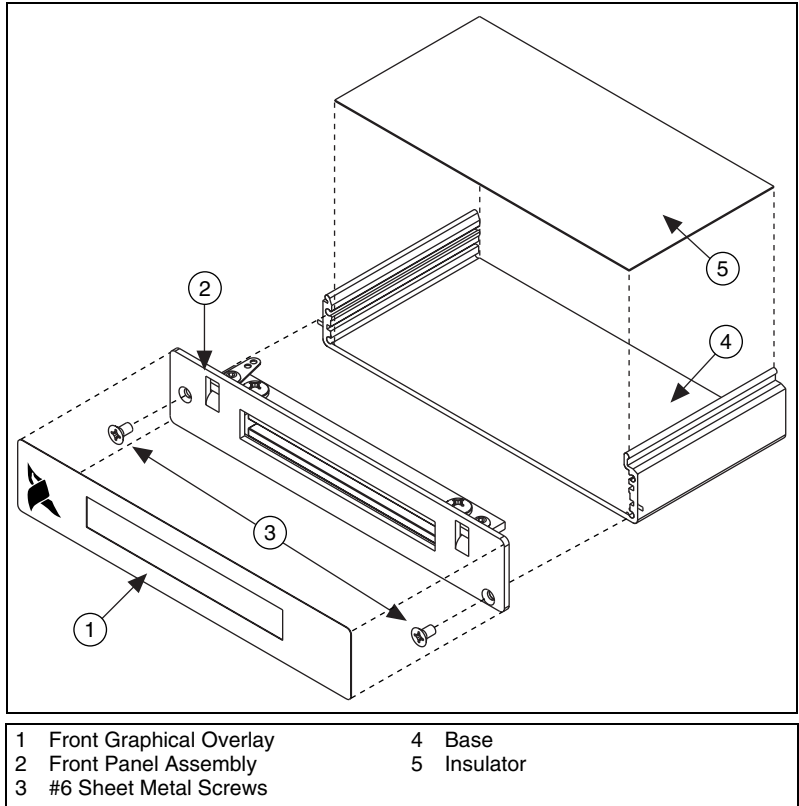

Figure 3. Installing the Front Panel Assembly

Attaching the Mating Connector

To attach the mating connector, complete the following steps:

1. Orient the 180-position connector as shown in Figure 4.
2. Attach the 180-position connector to the side of the PCB with the solder terminals.
3. Solder each pin of the 180-position connector to the PCB.

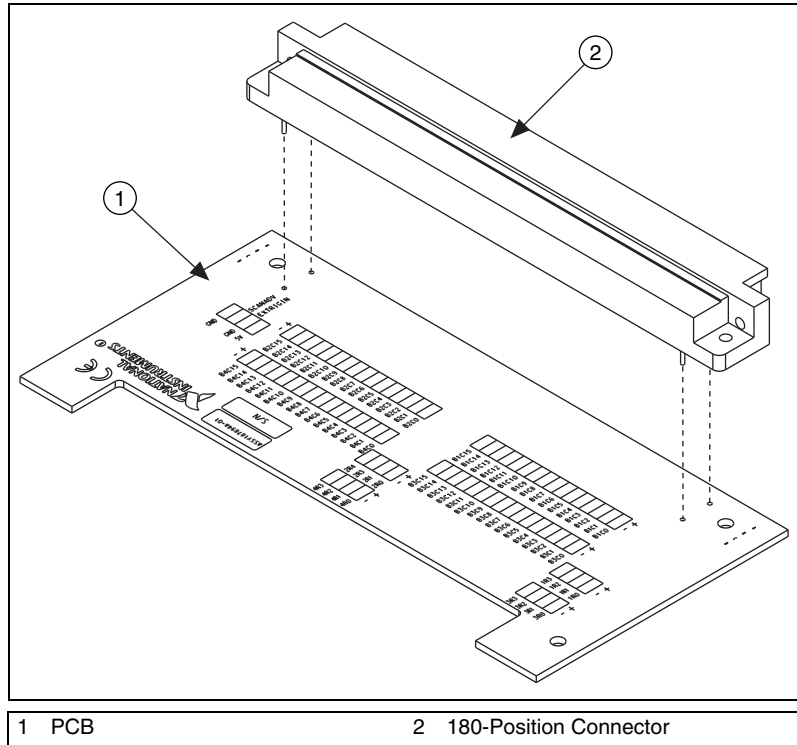

Figure 4. Attaching the Mating Connector

Connecting Signals



Note Refer to the *Safety Information* section before connecting or disconnecting any signal wires.

1. Prepare your signal wire by stripping the insulation no more than 3/16 of an inch.
2. Pull your signal wires at least one foot through the strain-relief opening on the front panel assembly as shown in Figure 5.

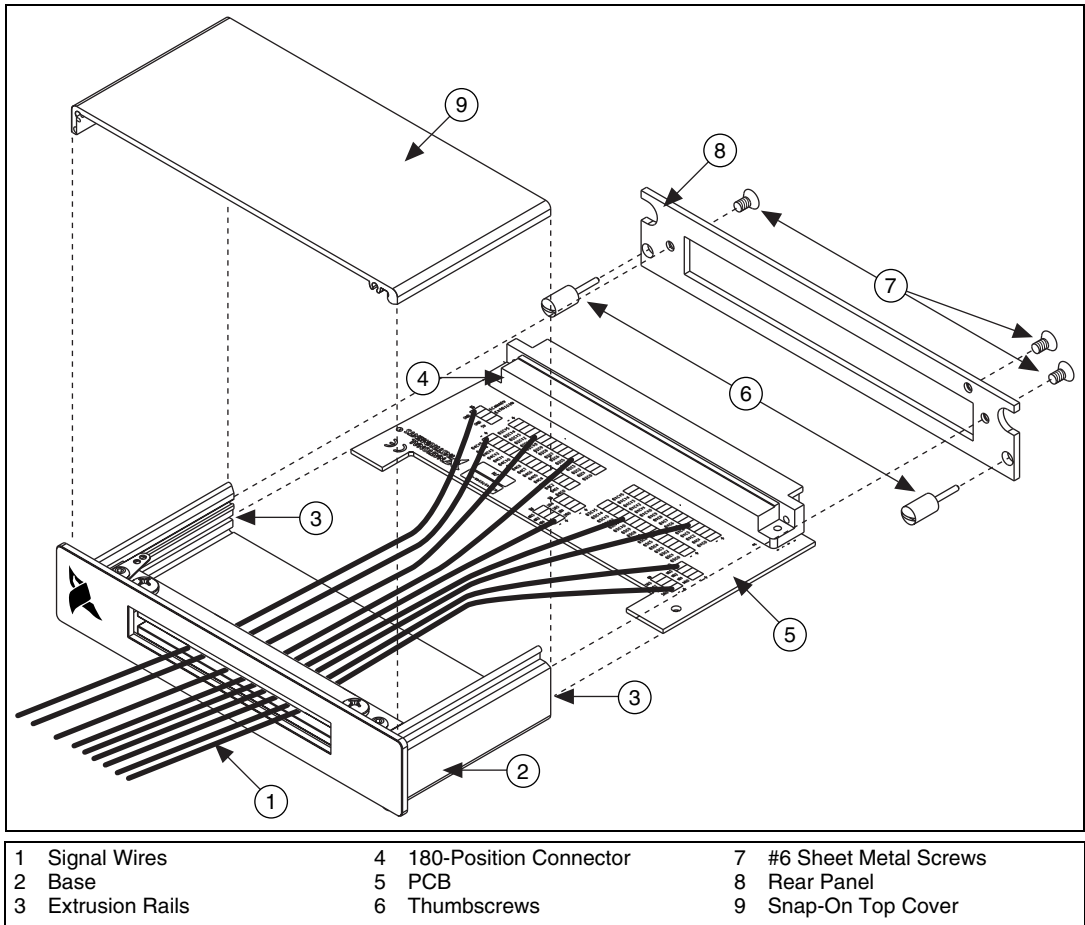
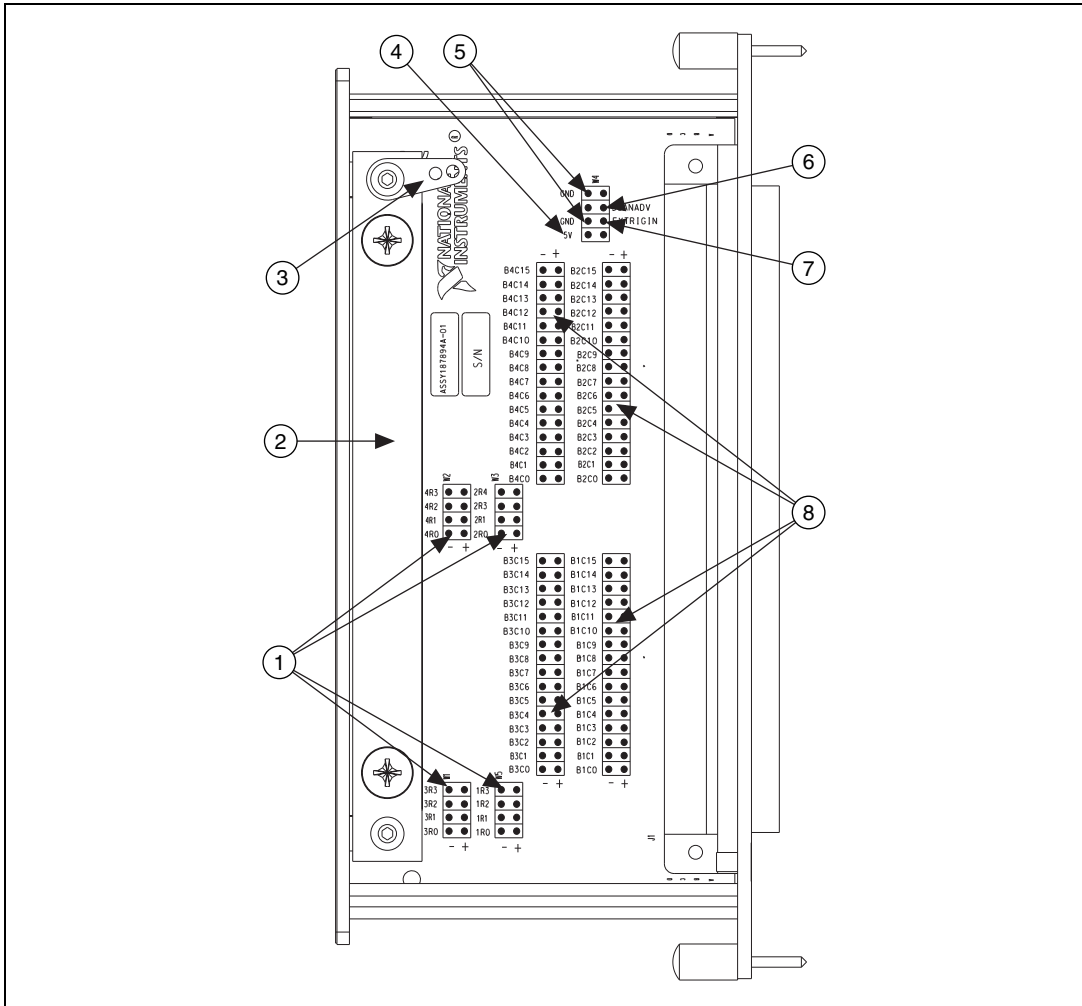

Figure 5. SCXI-1384K Custom Terminal Block Final Assembly

3. Connect the safety earth ground to the safety ground lug. Refer to the [Safety Information](#) section for connection information.
4. Connect the wires to the terminals by soldering the stripped end of the wire onto the terminal. Trim all soldered connections to a 1/16 inch maximum on the back side of the PCB. When connecting your signals, refer to the labeling in Figure 6.



- | | |
|---|--|
| <ol style="list-style-type: none"> 1 Row Connection Solder Terminals 2 Strain-Relief Bar Assembly 3 Safety Ground Lug 4 5 V Reference | <ol style="list-style-type: none"> 5 Ground Reference for Trigger Signal Solder Terminals 6 Scanner Advanced Output (SCANADV) Solder Terminal 7 External Trigger Input (EXTRIGIN) Solder Terminal 8 Column Connection Solder Terminals |
|---|--|

Figure 6. SCXI-1384K Custom Terminal Block Signal Connections

Completing the Custom Terminal Block

Refer to Figure 5 while following these steps:

1. Slide the PCB into the extrusion rails of the base, pulling excess signal wire back through the strain-relief assembly.
2. Install two thumbscrews into rear panel.
3. Attach the rear panel to the base with two sheet metal screws.
4. Tighten the strain-relief bar assembly.
5. Snap the top cover onto the base.
6. Secure the top cover to the rear panel with one sheet metal screw.

Installing The Terminal Block

To connect your SCXI-1384K custom terminal block to the SCXI-1129 module front connector, complete the following steps:

1. Connect the module front connector to its mating connector on the terminal block.
2. Tighten the top and bottom thumbscrews on the back of the terminal block rear panel to hold it securely in place.

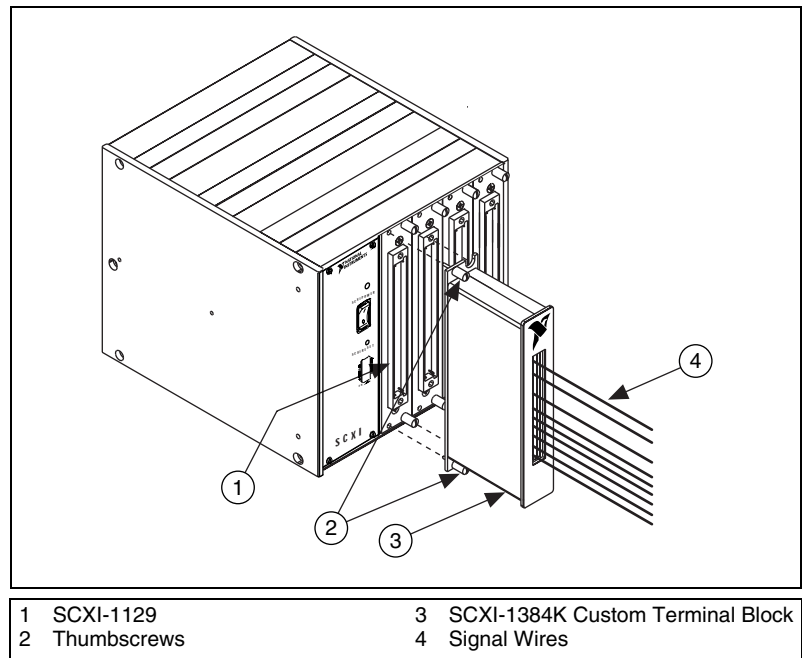

Figure 7. Installing the SCXI-1384K Custom Terminal Block

Specifications

All specifications are typical at 25 °C unless otherwise specified.

Maximum Voltage

Terminal to earth150 V_{rms} or VDC

Terminal to terminal150 V_{rms} or VDC

Environment

Operating temperature0 to 50 °C

Storage temperature-20 to 70 °C

Relative humidity10 to 90%

Safety

Designed in accordance with IEC61010-1, EN 61010-1, UL 3111-1, and CAN/CSA C22.2 No. 1010.1 for electrical measuring and test equipment

For use at altitudes up to 2000 m

Indoor use only

Installation Category I

Pollution Degree 2

Emissions and Immunity

EMC/EMICE, C-Tick and FCC Part 15
(Class A) Complaint

Electrical emissionsEN 55011 Class A at 10 m;
FCC Part 15A above 1 GHz

Electrical immunityEvaluated to EN 61326:1998,
Table 1



Note For full EMC and EMI compliance, you must operate this device with shielded cabling. See the *Declaration of Conformity (DoC)* for this product for any additional regulatory compliance information. To obtain the DoC for this product, click **Declaration of Conformity** at ni.com/hardref.nsf/. This website lists the DoCs by

product family. Select the appropriate product family, followed by your product, and a link to the DoC (in Adobe Acrobat format) appears. Click the Acrobat icon to download or read the DoC.

Technical Support Resources

NI Web Support

NI Web support is your first stop for help in solving installation, configuration, and application problems and questions. Online problem-solving and diagnostic resources include frequently asked questions, knowledge bases, product-specific troubleshooting wizards, manuals, drivers, software updates, and more. Web support is available through the Technical Support section of ni.com

Worldwide Support

NI has offices located around the world to help address your support needs. You can access our branch office Web sites from the Worldwide Offices section of ni.com. Branch office Web sites provide up-to-date contact information, support phone numbers, e-mail addresses, and current events.

If you have searched the technical support resources on our Web site and still cannot find the answers you need, contact your local office or NI corporate. For telephone support in the United States, dial 512 795 8248. For telephone support outside the United States, contact your local branch office:

Australia 03 9879 5166, Austria 0662 45 79 90 0, Belgium 02 757 00 20,
Brazil 011 284 5011, Canada (Calgary) 403 274 9391,
Canada (Ottawa) 613 233 5949, Canada (Québec) 514 694 8521,
Canada (Toronto) 905 785 0085, China (Shanghai) 021 6555 7838,
China (ShenZhen) 0755 3904939, Denmark 45 76 26 00, Finland 09 725 725 11,
France 01 48 14 24 24, Germany 089 741 31 30, Greece 30 1 42 96 427,
Hong Kong 2645 3186, India 91805275406, Israel 03 6120092, Italy 02 413091,
Japan 03 5472 2970, Korea 02 596 7456, Malaysia 603 9596711,
Mexico 5 280 7625, Netherlands 0348 433466, New Zealand 09 914 0488,
Norway 32 27 73 00, Poland 0 22 528 94 06, Portugal 351 1 726 9011,
Singapore 2265886, Spain 91 640 0085, Sweden 08 587 895 00,
Switzerland 056 200 51 51, Taiwan 02 2528 7227,
United Kingdom 01635 523545