

NI 9265 Calibration Procedure

[Français](#) [Deutsch](#) [日本語](#) [한국어](#) [简体中文](#)

ni.com/manuals

This document contains information about calibrating National Instruments 9265 modules using NI-DAQmx. This calibration procedure is intended for metrology labs.

This document does not discuss programming techniques or compiler configuration. The NI-DAQmx driver contains online help files that have compiler-specific instructions and detailed function explanations. You can install these help files when you install NI-DAQmx on the calibration computer.

Contents

Conventions	2
Software	2
Documentation	3
Calibration Interval	3
Test Equipment	4
Test Conditions	4
Calibration Procedure	4
Calibration Process Overview	4
Initial Setup	5
Verification Procedure	5
Specifications	9
Test Limits	9
Range	9
Test Point	9
1-Year Limits	9
Where to Go for Support.....	10

Conventions

The following conventions appear in this manual:

» The » symbol leads you through nested menu items and dialog box options to a final action. The sequence **File»Page Setup»Options** directs you to pull down the **File** menu, select the **Page Setup** item, and select **Options** from the last dialog box.



This icon denotes a note, which alerts you to important information.

bold Bold text denotes items that you must select or click in the software, such as menu items and dialog box options. Bold text also denotes parameter names and hardware labels.

italic Italic text denotes variables, emphasis, a cross-reference, or an introduction to a key concept. Italic text also denotes text that is a placeholder for a word or value that you must supply.

monospace Monospace text denotes text or characters that you should enter from the keyboard, sections of code, programming examples, and syntax examples. This font is also used for the proper names of disk drives, paths, directories, programs, subprograms, subroutines, device names, functions, operations, variables, filenames, and extensions.

monospace italic Italic text in this font denotes text that is a placeholder for a word or value that you must supply.

Software

Install NI-DAQmx 8.5 or later on the calibration computer. NI-DAQmx includes high-level function calls to simplify the task of writing software to calibrate devices. You must have the proper device driver installed on the calibration system before calibrating the device.



Note NI recommends that you install the NI-DAQmx driver software before physically installing the NI 9265. NI-DAQmx, available at ni.com/downloads, configures and controls the NI 9265.

NI-DAQmx supports a number of programming languages, including LabVIEW, LabWindows™/CVI™, Microsoft Visual C++ 6.0, Microsoft Visual Basic 6.0, Microsoft .NET, and Borland C++.

You can access the NI-DAQmx header file, `NIDAQmx.h`, like any standard library. You can find examples of how to use the NI-DAQmx driver in the `Program Files\National Instruments\NI-DAQ\Examples` directory.

Documentation

You might find the following documentation helpful as you write the calibration procedure:

- *NI-DAQmx Help*—This help file contains general information about measurement concepts, key NI-DAQmx concepts, and common applications that apply to all programming environments. To access this help file, select **Start»All Programs»National Instruments»NI-DAQ»NI-DAQmx Help**.
- *NI-DAQmx C Reference Help*—This help file contains C reference and general information about measurement concepts. To access this help file, select **Start»All Programs»National Instruments»NI-DAQ»NI-DAQmx C Reference Help**.
- *DAQ Getting Started Guide* for NI-DAQ 8.0 or later—This guide describes how to install NI-DAQmx for Windows software and NI-DAQmx-supported DAQ devices, and how to confirm that your device is operating properly. To access this guide, select **Start»All Programs»National Instruments»NI-DAQ»DAQ Getting Started Guide**.



Note The documents above are installed with NI-DAQmx. You can also download the latest versions from the NI Web site at ni.com/manuals.

- *NI 9265 Operating Instructions and Specifications*—This document describes how to use the NI 9265 and includes specifications and terminal assignments for the NI 9265. You can download the latest version of this document from the NI Web site at ni.com/manuals.

Calibration Interval

The NI 9265 should be calibrated at a regular interval as defined by the measurement accuracy requirements of your application. National Instruments recommends that you routinely perform a complete calibration at least once every year. You can shorten this interval based on the accuracy demands of your application or requirements of your processes.

Test Equipment

National Instruments recommends that you use the following equipment for calibrating the NI 9265.

Table 1. Recommended Equipment

Equipment	Recommended Model	Requirements
DMM	NI 4070 DMM	If this instrument is unavailable, use a multiranging 6 1/2 digit DMM with a DC current measurement accuracy of 400 ppm.
Chassis	NI cDAQ-9172	—
Bench-top power supply	—	9–36 VDC output voltage

Test Conditions

Follow these guidelines to optimize the connections and the environment:

- Keep connections to the device as short as possible. Long cables and wires act as antennae, picking up extra noise that can affect measurements.
- Use shielded copper wire for all cable connections to the device. Use twisted-pair wire to eliminate noise and thermal offsets.
- Maintain an ambient temperature of 23 ± 5 °C. The device temperature will be greater than the ambient temperature.
- Keep relative humidity below 80%.
- Allow a warm-up time of at least 10 minutes to ensure that the measurement circuitry is at a stable operating temperature.

Calibration Procedure

This section provides instructions for verifying the performance of the NI 9265.

Calibration Process Overview

The calibration process consists of the following steps:

1. *Initial Setup*—Configure the device in NI-DAQmx.
2. *Verification Procedure*—Verify the existing operation of the device. This step confirms whether the device is operating within its specified range and whether it needs adjustment.

3. *Adjustment*—If the device does not fall within the desired specifications, submit the device to NI for a factory calibration to adjust the calibration constants.
4. *Verification Procedure*—Perform another verification to ensure that the device operates within its specifications after adjustment.

The first two steps are explained in the following sections.

Initial Setup

You must configure the device in Measurement & Automation Explorer (MAX) to communicate with NI-DAQmx.

Complete the following steps to configure a device in MAX:

1. Install the NI-DAQmx driver software.
2. Make sure that no power is connected to the module terminals. If the system is in a nonhazardous location, the chassis power can be on when you install the module.
3. Insert the module into an available slot in the cDAQ-9172 chassis.
4. Launch MAX.
5. Right-click the device name and select **Self-Test** to ensure that the device is working properly.



Note When a device is configured with MAX, it is assigned a device name. Each function call uses this device name to determine which DAQ device to calibrate. This document uses `dev1` to refer to the device name. In the following procedures, use the device name as it appears in MAX.

Verification Procedure

Verification determines how well the device is meeting its specifications. By completing this procedure, you can see how the device has drifted over time, which helps you determine the appropriate calibration interval for your application. Table 3 in the *Test Limits* section shows all acceptable settings for the device type. Throughout the verification process, use Table 3 to determine if the device is operating within its specified range.

Complete the following steps to test the performance of the device:

1. Connect the negative lead of the bench-top power supply to Power Supply COM, and the positive lead of the power supply to the supply terminal, V_{sup} .

2. Connect the DMM to the channel you want to verify. Connect the negative output of the DMM to COM and the positive output of the DMM to AO. Refer to Figure 1 for the terminal assignments of the NI 9265.

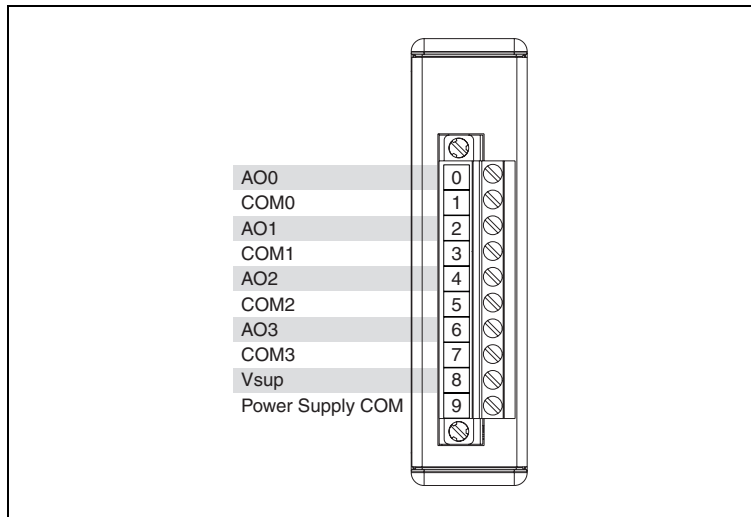

Figure 1. NI 9265 Terminal Assignments

3. Set the output current of the selected channel of the NI 9265 to a Test Point value indicated in Table 3.
4. If you use C function calls, create a task using `DAQmxCreateTask`, as shown in the following table. If you use LabVIEW, skip this step. The task is created in step 5 in LabVIEW.

LabVIEW Block Diagram	NI-DAQmx Function Call
<p>LabVIEW does not require this step.</p>	<p>Call <code>DAQmxCreateTask</code> with the following parameters:</p> <p>taskName: <code>AOVerificationTask</code></p> <p>taskHandle: <code>&taskHandle</code></p>

5. Create and configure an AO current channel using the DAQmx Create Virtual Channel VI, as shown in the following table.



Note Throughout the procedure, refer to the NI-DAQmx function parameters for the LabVIEW input values. Refer to the block diagram images for the correct instance to use for polymorphic VIs.

LabVIEW Block Diagram	NI-DAQmx Function Call
	<p>Call DAQmxCreateAOCurrentChan with the following parameters:</p> <p>taskHandle: taskHandle physicalChannel: dev1/aoX* nameToAssignToChannel: myCurrentChannel terminalConfig: DAQmx_Val_Cfg_Default minVal: 0 maxVal: 0.02 units: DAQmx_Val_Amps customScaleName: NULL</p>
<p>* X refers to the channel number.</p>	

6. Configure the timing properties for the current generation using the DAQmx Timing VI, as shown in the following table.

LabVIEW Block Diagram	NI-DAQmx Function Call
	<p>Call DAQmxCfgSampClkTiming with the following parameters:</p> <p>taskHandle: taskHandle source: NULL rate: 100000.0 activeEdge: DAQmx_Val_Rising sampleMode: DAQmx_Val_FiniteSamps sampsPerChan: 10000</p>

7. Generate the current output using the DAQmx Write VI, as shown in the following table.

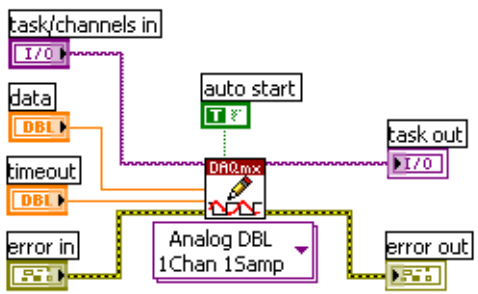
LabVIEW Block Diagram	NI-DAQmx Function Call
 <p>The diagram shows a DAQmx Write VI block. Its inputs include: 'task/channels in' (I/O connector), 'data' (DBL connector), 'timeout' (DBL connector), and 'error in' (Error connector). The DAQmx Write VI is connected to an 'Analog DBL 1Chan 15amp' block. The output of this block is connected to an 'error out' (Error connector). The DAQmx Write VI is also connected to a 'task out' (I/O connector). An 'auto start' VI block is connected to the DAQmx Write VI.</p>	<p>Call DAQmxWriteAnalogF64 with the following parameters:</p> <p>taskHandle: taskHandle numSampsPerChan: 1 autoStart: 1 timeout: 10.0 dataLayout: DAQmx_Val_GroupByChannel writeArray: &data sampsPerChanWritten: &sampsWritten reserved: NULL</p>

8. Compare the resulting values that the DMM shows to the Upper Limit and Lower Limit values in Table 3. If the result is between these values, the device passes the test.
9. Clear the generation using the DAQmx Clear Task VI, as shown in the following table.

LabVIEW Block Diagram	NI-DAQmx Function Call
 <p>The diagram shows a DAQmx Clear Task VI block. Its input is 'task in' (I/O connector). The output is 'error out' (Error connector).</p>	<p>Call DAQmxClearTask with the following parameter:</p> <p>taskHandle: taskHandle</p>

10. Repeat steps 3 through 9 for both Test Point values. NI recommends that you verify all values, although you can save time by verifying only the values used in your application.
11. Repeat steps 2 through 10 for all channels.
12. Disconnect the DMM from the device.

Specifications

The values in the following table are based on calibrated scaling coefficients, which are stored in the onboard EEPROM. The following calibration specifications are for 23 ± 5 °C.

Table 2. NI 9265 Accuracy

Percent of Reading (Gain Error)	Percent of Range* (Offset Error)
0.10%	0.12%
* Range equals 0 to 20.6 mA	

Test Limits

Table 3 lists the specifications that the NI 9265 should meet if it has been one year between calibrations. The following definitions describe how to use the information from Table 3.

Range

Range refers to the minimum or maximum current range of an output signal.

Test Point

The *Test Point* is the current value that is output for verification purposes. This value is broken down into two columns—*Location* and *Value*. *Location* refers to where the test value fits within the test range. *Value* refers to the current value to be verified. *Max* refers to the maximum value and *Min* refers to the minimum value.

1-Year Limits

The *1-Year Limits* column contains the *Upper Limits* and *Lower Limits* for the test point value. That is, when the device is within its 1-year calibration interval, the test point value should fall between these upper and lower limit values.

Table 3. NI 9265 Verification Test Limits

Range (mA)		Test Point		1-Year Limits	
Minimum	Maximum	Location	Value (mA)	Lower Limit (mA)	Upper Limit (mA)
0	20	Min	1	0.9739	1.0261
0	20	Max	19	18.9559	19.0441

Where to Go for Support

The National Instruments Web site is your complete resource for technical support. At ni.com/support you have access to everything from troubleshooting and application development self-help resources to email and phone assistance from NI Application Engineers.

National Instruments corporate headquarters is located at 11500 North Mopac Expressway, Austin, Texas, 78759-3504. National Instruments also has offices located around the world to help address your support needs. For telephone support in the United States, create your service request at ni.com/support and follow the calling instructions or dial 512 795 8248. For telephone support outside the United States, contact your local branch office:

Australia 1800 300 800, Austria 43 662 457990-0,
Belgium 32 (0) 2 757 0020, Brazil 55 11 3262 3599,
Canada 800 433 3488, China 86 21 5050 9800,
Czech Republic 420 224 235 774, Denmark 45 45 76 26 00,
Finland 358 (0) 9 725 72511, France 01 57 66 24 24,
Germany 49 89 7413130, India 91 80 41190000, Israel 972 3 6393737,
Italy 39 02 41309277, Japan 0120-527196, Korea 82 02 3451 3400,
Lebanon 961 (0) 1 33 28 28, Malaysia 1800 887710,
Mexico 01 800 010 0793, Netherlands 31 (0) 348 433 466,
New Zealand 0800 553 322, Norway 47 (0) 66 90 76 60,
Poland 48 22 328 90 10, Portugal 351 210 311 210,
Russia 7 495 783 6851, Singapore 1800 226 5886,
Slovenia 386 3 425 42 00, South Africa 27 0 11 805 8197,
Spain 34 91 640 0085, Sweden 46 (0) 8 587 895 00,
Switzerland 41 56 2005151, Taiwan 886 02 2377 2222,
Thailand 662 278 6777, Turkey 90 212 279 3031,
United Kingdom 44 (0) 1635 523545

National Instruments, NI, ni.com, and LabVIEW are trademarks of National Instruments Corporation. Refer to the *Terms of Use* section on ni.com/legal for more information about National Instruments trademarks. Other product and company names mentioned herein are trademarks or trade names of their respective companies. For patents covering National Instruments products/technology, refer to the appropriate location: **Help»Patents** in your software, the `patents.txt` file on your media, or the *National Instruments Patent Notice* at ni.com/patents.