

USER GUIDE

MID-7604/7602 Power Drive

This user guide describes the electrical and mechanical aspects of the MID-7604/7602 power drive and how to use the power drive with your motion controller.

Contents

Conventions	2
Introduction	3
What You Need to Get Started	3
Compliance with FCC/Canada Radio Frequency Interference	
Regulations.....	4
Safety Information	6
Front Panel Switches.....	9
Back Panel Connector Wiring.....	10
Host Bus Interlock Circuit	11
Front Panel LEDs.....	11
Driver Fault Output LEDs	12
Driver Inhibit LEDs	12
Limit Status LEDs	12
Front Panel DIP Switch Settings.....	12
Microstepping Selection	13
Output Current Settings	14
Inhibit Input Polarity Setting	16
Limit Status LED Polarity Setting	16
Back Panel Connector Wiring.....	17
Motor Power Terminal Blocks	17
Encoder Terminal Blocks	18
Limit Switch Terminal Blocks.....	21
Breakpoint and Trigger Terminal Blocks	21
Analog I/O Terminal Blocks.....	22
Accessories for Optional Use.....	23
Amplifier/Driver Command Signals	24
Stepper Motor Configurations	25
Specifications	28
Where to Go for Support.....	32

Conventions

The following conventions are used in this manual:



This icon denotes a note, which alerts you to important information.



This icon denotes a caution, which advises you of precautions to take to avoid injury, data loss, or a system crash. When this symbol is marked on a product, refer to the *Specifications* section of this guide for information about precautions to take.



This icon denotes a warning, which advises you of precautions to take to avoid being electrically shocked. When symbol is marked on a product, it denotes a warning advising you to take precautions to avoid electrical shock.



When symbol is marked on a product, it denotes a component that may be hot. Touching this component may result in bodily injury.

bold

Bold text denotes items that you must select or click in the software, such as menu items and dialog box options. Bold text also denotes parameter names.

italic

Italic text denotes variables, emphasis, a cross reference, or an introduction to a key concept. This font also denotes text that is a placeholder for a word or value that you must supply.

monospace

Text in this font denotes text or characters that you should enter from the keyboard, sections of code, programming examples, and syntax examples. This font is also used for the proper names of disk drives, paths, directories, programs, subprograms, subroutines, device names, functions, operations, variables, filenames, and extensions.

Introduction

The National Instruments MID-7604/7602 power drive is a complete power amplifier and system interface for use with four or two axes of simultaneous stepper motion control. Ideally suited to industrial and laboratory applications, the MID-7604/7602 has everything you need to connect motors, encoders, limit switches, I/O, and other motion hardware to National Instruments motion controllers.

The MID-7604/7602 can drive a broad range of stepper motors with its rugged microstepping bipolar chopper driver and user-selectable current-per-phase settings. In all configurations, power supplies are built-in and use standard 230/115 VAC for operation. Electronics are fan-cooled to assure reliable operation.

The MID-7604/7602 simplifies field wiring through separate encoder, limit switch, and motor power removable screw terminal connector blocks for each axis. The terminal blocks do not require special wiring tools for installation. The MID-7604/7602 connects to National Instruments motion controllers using a 68-pin, high-density interconnect cable.

The MID-7604/7602 has four levels of amplifier inhibit/disable protection for motion system shutdown. The front panel contains both enable and power switches for direct motor inhibiting and system power-down operations. The MID-7604/7602 also has a host bus power interlock that activates an internal driver inhibit signal if the host computer is shut down or the motion controller interface cable is disconnected. The inhibit input from the back panel connectors also inhibits the stepper drives when activated.

The MID-7604/7602 is packaged in a rugged, lightweight enclosure that can be used as a benchtop unit, panel mounted using a panel-mount kit, or rack mounted using a 19-inch standard rack kit.

What You Need to Get Started

To set up and use your MID-7604/7602 accessory, you must have the following items:

- MID-7604/7602 power drive
- Power cord (IEC type)

- ❑ Panel-mount kit (part number 187243-01)
- ❑ One of the following shielded cable assemblies, as applicable:
 - SH68-C68-S (part number 186381-02)
 - SHC68-C68-S (part number 186380-02)

For detailed specifications for the MID-7604/7602 power drive, refer to the *Specifications* section of this guide.

Compliance with FCC/Canada Radio Frequency Interference Regulations

Determining FCC Class

The Federal Communications Commission (FCC) has rules to protect wireless communications from interference. The FCC places digital electronics into two classes. These classes are known as Class A (for use in industrial-commercial locations only) or Class B (for use in residential or commercial locations). All National Instruments (NI) products are FCC Class A products.

Depending on where it is operated, this Class A product could be subject to restrictions in the FCC rules. (In Canada, the Department of Communications (DOC), of Industry Canada, regulates wireless interference in much the same way.) Digital electronics emit weak signals during normal operation that can affect radio, television, or other wireless products.

All Class A products display a simple warning statement of one paragraph in length regarding interference and undesired operation. The FCC rules have restrictions regarding the locations where FCC Class A products can be operated.

Consult the FCC Web site at www.fcc.gov for more information.

FCC/DOC Warnings

This equipment generates and uses radio frequency energy and, if not installed and used in strict accordance with the instructions in this manual and the CE marking Declaration of Conformity¹, may cause interference to

¹ The CE marking Declaration of Conformity contains important supplementary information and instructions for the user or installer.

radio and television reception. Classification requirements are the same for the Federal Communications Commission (FCC) and the Canadian Department of Communications (DOC).

Changes or modifications not expressly approved by NI could void the user's authority to operate the equipment under the FCC Rules.

Class A

Federal Communications Commission

This equipment has been tested and found to comply with the limits for a Class A digital device, pursuant to part 15 of the FCC Rules. These limits are designed to provide reasonable protection against harmful interference when the equipment is operated in a commercial environment. This equipment generates, uses, and can radiate radio frequency energy and, if not installed and used in accordance with the instruction manual, may cause harmful interference to radio communications. Operation of this equipment in a residential area is likely to cause harmful interference in which case the user is required to correct the interference at their own expense.

Canadian Department of Communications

This Class A digital apparatus meets all requirements of the Canadian Interference-Causing Equipment Regulations.

Cet appareil numérique de la classe A respecte toutes les exigences du Règlement sur le matériel brouilleur du Canada.

Compliance with EU Directives

Users in the European Union (EU) should refer to the Declaration of Conformity (DoC) for information¹ pertaining to the CE marking. Refer to the Declaration of Conformity (DoC) for this product for any additional regulatory compliance information. To obtain the DoC for this product, visit ni.com/certification, search by model number or product line, and click the appropriate link in the Certification column.

¹ The CE marking Declaration of Conformity contains important supplementary information and instructions for the user or installer.

Safety Information



Caution The following paragraphs contain important safety information you *must* follow when installing and operating the device.

Do *not* operate the device in a manner not specified in the documentation. Misuse of the device may result in a hazard and may compromise the safety protection built into the device. If the device is damaged, turn it off and do *not* use it until service-trained personnel can check its safety. If necessary, return the device to National Instruments for repair.

Keep away from live circuits. Do *not* remove equipment covers or shields unless you are trained to do so. If signal wires are connected to the device, hazardous voltages can exist even when the equipment is turned off. To avoid a shock hazard, do *not* perform procedures involving cover or shield removal unless you are qualified to do so. Disconnect all field power prior to removing covers or shields.

If the device is rated for use with hazardous voltages ($>30 V_{\text{rms}}$, $42.4 V_{\text{pk}}$, or $60 V_{\text{dc}}$), it may require a safety earth-ground connection wire. Refer to the device specifications for maximum voltage ratings.

Because of the danger of introducing additional hazards, do *not* install unauthorized parts or modify the device. Use the device only with the chassis, modules, accessories, and cables specified in the installation instructions. All covers and filler panels *must* be installed while operating the device.

Do *not* operate the device in an explosive atmosphere or where flammable gases or fumes may be present. Operate the device only at or below the pollution degree stated in the specifications. Pollution consists of any foreign matter—solid, liquid, or gas—that may reduce dielectric strength or surface resistivity. The following is a description of pollution degrees.

- Pollution Degree 1—No pollution or only dry, nonconductive pollution occurs. The pollution has no effect.
- Pollution Degree 2—Normally only nonconductive pollution occurs. Occasionally, nonconductive pollution becomes conductive because of condensation.
- Pollution Degree 3—Conductive pollution or dry, nonconductive pollution occurs. Nonconductive pollution becomes conductive because of condensation.

Clean the device and accessories by brushing off light dust with a soft, nonmetallic brush. Remove other contaminants with a stiff, nonmetallic brush. The unit *must* be completely dry and free from contaminants before returning it to service.

You *must* insulate signal connections for the maximum voltage for which the device is rated. Do *not* exceed the maximum ratings for the device. Remove power from signal lines before connection to or disconnection from the device.

The MID 7604/7602 drive is not a measurement device. However, if you want to make a measurement of the circuits or devices connected to the drive, operate the device only at or below the installation category stated in the specifications. Installation categories are listed below.

Installation Category¹: Measurement circuits are subjected to working voltages² and transient stresses (overvoltage) from the circuit to which they are connected during measurement or test. Installation Category establishes standardized impulse withstand voltage levels that commonly occur in electrical distribution systems. The following is a description of Installation (Measurement³) Categories:

- Installation Category I is for measurements performed on circuits *not* directly connected to the electrical distribution system referred to as MAINS⁴ voltage. This category is for measurements of voltages from specially protected secondary circuits. Such voltage measurements include signal levels, special equipment, limited-energy parts of equipment, circuits powered by regulated low-voltage sources, and electronics.
- Installation Category II is for measurements performed on circuits directly connected to the electrical distribution system. This category refers to local-level electrical distribution, such as that provided by a standard wall outlet (for example, 115 V for U.S. or 230 V for Europe). Examples of Installation Category II are measurements performed on household appliances, portable tools, and similar products.

¹ Installation Categories as defined in electrical safety standard IEC 61010-1.

² Working voltage is the highest rms value of an AC or DC voltage that can occur across any particular insulation.

³ Installation Category is also referred to as Measurement Category.

⁴ MAINS is defined as the (hazardous live) electrical supply system to which equipment is designed to be connected for the purpose of powering the equipment. Suitably rated measuring circuits may be connected to the MAINS for measuring purposes.

- Installation Category III is for measurements performed in the building installation at the distribution level. This category refers to measurements on hard-wired equipment such as equipment in fixed installations, distribution boards, and circuit breakers. Other examples are wiring, including cables, bus-bars, junction boxes, switches, socket-outlets in the fixed installation, and stationary motors with permanent connections to fixed installations.
- Installation Category IV is for measurements performed at the primary electrical supply installation (<1,000 V). Examples include electricity meters and measurements on primary overcurrent protection devices and on ripple control units.

Figure 1 is a diagram of a sample installation.

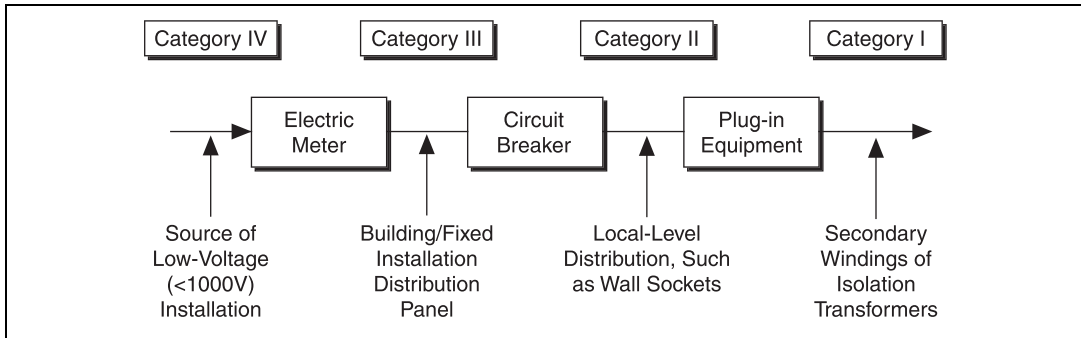

Figure 1. Sample Installation of the MID-7604/7602



Warning The stepper motor connectors on this drive are energized when the unit is powered on. Disconnect the MID-7604/7602 unit from the power outlet *before* connecting wires to or disconnecting wires from the stepper connectors. Strip back the insulation of the stepper wires to the stepper connectors no more than 7 mm. ***Failure to do so could result in electric shock leading to serious bodily injury or death.***



Hot Surface The bottom surface of the MID-7604/7602 can get very hot to the touch under certain conditions. To avoid a burn hazard, refer to [Output Current Settings](#) in the [Front Panel DIP Switch Settings](#) section of this guide for the appropriate current setting and safety hazards.

Front Panel Switches

Figure 2 shows the front panel of your MID-7604/7602. The DIP switches are shown with the detachable metal cover plate removed.

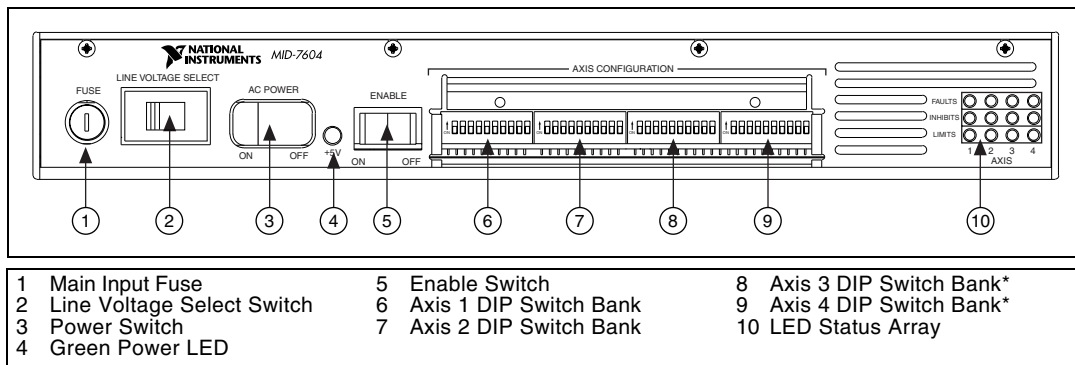

Figure 2. MID-7604/7602 Front Panel



Note Items followed by an asterisk (*) are available on the MID-7604 only.

The two rocker switches on the MID-7604/7602 front panel are the AC POWER and ENABLE. Figure 2 shows the location of these switches.

The AC POWER switch energizes the motor bus (+24 V) and the logic (+5 V) power supplies. When switched on, the green power LED labeled +5 V illuminates. If this LED fails to illuminate, check the power cord and main input fuse on the front panel.

The ENABLE switch enables or inhibits the stepper drivers. If the ENABLE switch is in the inhibit position (off), the stepper drivers are inhibited, and the yellow LEDs (the middle row of the LED status array) for all axes illuminate. Refer to the [Front Panel LEDs](#) section of this guide for more information.

Both the AC POWER and ENABLE switches can inhibit the stepper drivers. However, as long as the AC POWER switch is on, only the stepper driver output stages are disabled. The remaining circuitry remains active, including the quadrature encoder circuit.



Caution You *must* change the MID-7604/7602 main input fuse on the front panel if you change the line voltage from the factory setting. Refer to the [Specifications](#) section of this guide for fuse specifications.

Back Panel Connector Wiring

Figure 3 shows the connectors located on the back panel of your MID-7604/7602.

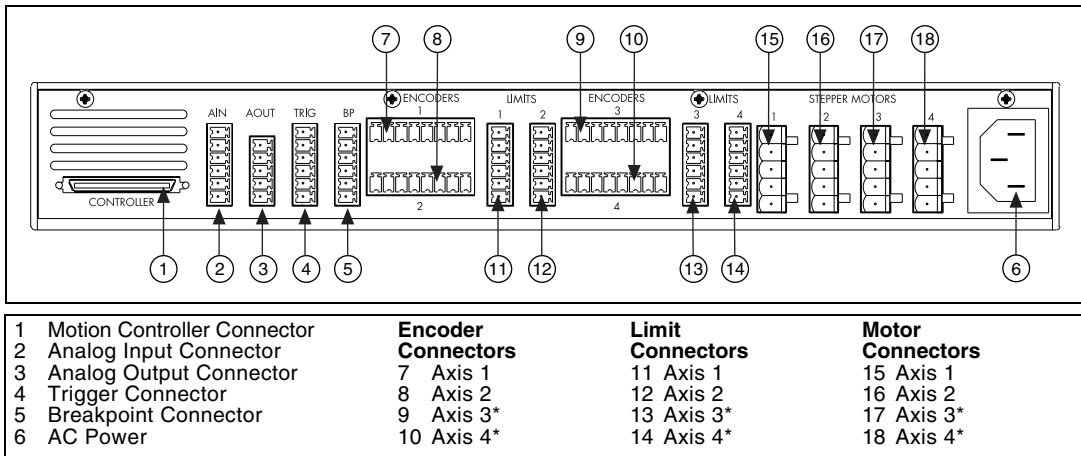

Figure 3. MID-7604/7602 Back Panel Connectors



Note Items followed by an asterisk (*) are available on the MID-7604 only.



Caution Be sure to turn off the ENABLE switch and the main AC power to your MID-7604/7602 and host computer *before* connecting the accessory to your motion controller.



Warning The stepper motor connectors on this drive are energized when the unit is powered on. Disconnect the MID-7604/7602 unit from the power outlet *before* connecting wires to or disconnecting wires from the stepper connectors. Strip back the insulation of the stepper wires to the stepper connectors no more than 7 mm. **Failure to do so could result in electric shock leading to serious bodily injury or death.**

1. Use the interface cable to connect the motion controller to the MID-7604/7602. Wire the motor power, limit switch, encoder, and I/O terminal blocks as described in this guide and to your specific system requirements.



Caution You *must* change the MID-7604/7602 main input fuse on the front panel if you change the line voltage from the factory setting. Refer to the [Specifications](#) section of this guide for fuse specifications.

2. Use the **LINE VOLTAGE SELECT** switch to configure the MID-7604/7602 for 115 VAC, 60 Hz or 230 VAC, 50 Hz operation.

For proper operation, you must set this switch to match your power source.

3. Finally, install the power cord into the back panel AC connector and plug it in to a correctly rated power source.

Host Bus Interlock Circuit

The MID-7604/7602 has a host bus interlock circuit that monitors the presence of +5 V from the host computer and disables the MID-7604/7602 when the voltage is not present or falls out of tolerance. This circuit shuts down the stepper drives for all axes by activating the inhibit when the host computer is disconnected from the MID-7604/7602 or inadvertently shut down. Activation of the host bus interlock circuitry illuminates the yellow LEDs (middle row) of the LED status array for all axes. Refer to the *Front Panel LEDs* section of this guide for more information.

Front Panel LEDs

The front panel LEDs consist of a single green LED to indicate if the main power is active and an LED status array of 3 rows by 4 columns that provides a variety of status information. Refer to Figure 2 for the location of the front panel LEDs.

If the DC power supplies are active, the green power LED illuminates. If this LED fails to illuminate, check the power cord and the main input fuse on the front panel.

The LED status array is arranged by motor axes. Each of the four columns represents an axis, and each of the three rows represents a particular status. Table 1 summarizes the axis and corresponding status for each LED in the 3 × 4 array.

Table 1. Front Panel LED Indicators

Status	Motor Axis			
Driver Fault Output (red)	1	2	3	4
Driver Inhibit (yellow)	1	2	3	4
Limit Status (green)	1	2	3	4

Driver Fault Output LEDs

The top row of LEDs indicates the status of the stepper drivers. An LED illuminates red when an overcurrent condition or a problem with the motor bus voltage on that axis occurs.

Driver Inhibit LEDs

The middle row of LEDs indicates whether or not a motor axis is inhibited. An axis is inhibited and the LED illuminates yellow in the following instances: if the host bus interlock circuitry is activated from the back panel, if the **ENABLE** switch on the front panel is in the inhibit position, if the motion controller's inhibit signal is low, or if the per-axis inhibit input is actively driven.

The polarity of the per-axis inhibit input is selectable from the front panel DIP switches. Refer to the *Front Panel DIP Switch Settings* section of this guide for more information.

Limit Status LEDs

The bottom row of LEDs indicates whether or not a limit switch is currently active. The LED illuminates green if either the forward or reverse limit switch is active for each axis. You can select the polarity for the limit status LEDs from the front panel DIP switches. Refer to the *Front Panel DIP Switch Settings* section of this guide for more information.

Front Panel DIP Switch Settings

The MID-7604/7602 front panel has a detachable metal plate that when removed provides access to four 10-position DIP switch banks. Refer to Figure 2 for the location of these switches.

Use the first nine DIP switches on each 10-position DIP switch bank to configure the microstep rate, peak output current, and current reduction for each axis. The DIP switch banks for axes 1 and 2 contain a global DIP switch, switch 10, which sets the polarity of the inhibit input and the polarity of the limit status LED, respectively. Figure 4 shows the DIP switch bank layout.

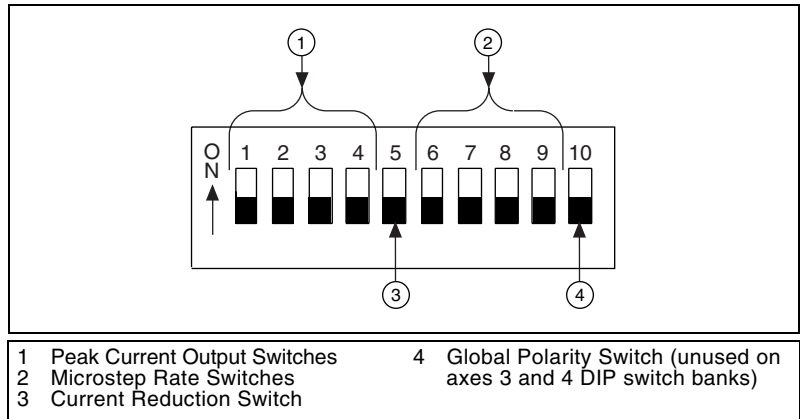

Figure 4. DIP Switch Bank Layout



Microstepping Selection



The MID-7604/7602 uses bipolar chopper, two-phase microstepping drivers with a broad range of microstep rates. The factory default setting is 10-times microstepping (2,000 steps/rev with standard 1.8° stepper motors). Table 2 shows the DIP switch settings for all possible microstep settings. DIP switches 6 through 9 control the microstep rate on a per-axis basis.

Table 2. Microstep Rate DIP Switch Setting

Binary Selections		Decimal Selections	
Switch	Microsteps/Step	Switch	Microsteps/Step
	2 (half step)		5
	4		10 (factory default)
	8		25
	16		50
	32		125
	64		250

Table 2. Microstep Rate DIP Switch Setting (Continued)









Binary Selections	
Switch	Microsteps/Step
	128
	256









Decimal Selections	
Switch	Microsteps/Step
	Do not use
	Do not use

Output Current Settings

The MID-7604/7602 can provide 0.20–1.4 A peak (0.14–1 A RMS), depending on the peak output current DIP switch settings for each axis. DIP switches 1 through 4 control the peak output current. Table 3 shows the DIP switch settings for all possible peak output current settings.

Table 3. Peak Output Current DIP Switch Setting

Switch	Peak Output (A)
	1.40
	1.20
	1.00
	0.85
	0.70
	0.60
	0.55
	0.50 (factory default)

Switch	Peak Output (A)
	0.35
	0.30
	0.28
	0.27
	0.25
	0.24
	0.23
	0.20

If you are connecting multiple motors to your MID-7604/7602, verify that the total power dissipated by the motors at any given time is less than the total power the drive can provide. If the total power requirement exceeds the capability of the drive at any point, the drive will provide less power to the motors than desired until the total power requirement drops back down. The MID-7604/7602 may overheat under continuous operation with loads that exceed specified limits.



Caution A fire safety hazard exists when the total power dissipated by the motors exceeds 80 W continuous for a sustained period of time.



To determine the maximum total power dissipation of all of the motors combined, add up the maximum power each motor can dissipate. If this value is less than or equal to 80 W continuous, you will not exceed the capabilities of the MID-7604/7602.

If the value is greater than 80 W continuous, you may still be within the operating capabilities of the MID-7604/7602, since it is unlikely you will run all of your motors simultaneously at their maximum levels. Make a reasonable estimation of the maximum power your motors will require at any given time and verify that this value is less than 80 W continuous.

You can configure the MID-7604/7602 stepper drivers in a current reduction mode on a per-axis basis. This configuration is useful to minimize motor heating when you are not stepping. With current reduction enabled, the current decreases by 50% when no stepping has occurred for approximately 500 ms. DIP switch 5 controls current reduction on a per-axis basis. When this DIP switch is on, current reduction is enabled. When this DIP switch is off, current reduction is disabled. The factory default setting is current reduction enabled.

Table 4 shows the available settings for DIP switch 5.

Table 4. Current Reduction DIP Switch Settings



Switch Setting	Operation
	Current reduction enabled (factory default)
	Current reduction disabled

Inhibit Input Polarity Setting

The MID-7604/7602 has a DIP switch that globally sets the polarity for the inhibit input for all axes. DIP switch 10 on the axis 1 DIP switch bank controls this setting. Refer to Figures 2 and 4 for the location of this switch.

The factory default setting of DIP switch 10 is active-low. If the inhibit input is active, the axis is inhibited and the yellow status LED (middle row) illuminates for the axis. Table 5 shows the DIP switch setting for the inhibit input polarity selection.

Table 5. Inhibit Input Polarity DIP Switch Settings



Axis 1 Switch Setting	Operation
	Active-high
	Active-low (factory default)

Limit Status LED Polarity Setting

The MID-7604/7602 has a DIP switch that globally sets the polarity for the Limit Status LED. DIP switch 10 on the axis 2 DIP switch bank controls this setting. Refer to Figures 2 and 4 for the location of this switch.

The factory default setting is active-low. Typically, you set the switch to match your controller's polarity setting, so that if either the reverse or forward limits for an axis are active, the green status LED (on the bottom row) for the axis illuminates. This DIP switch alters only the polarity for the LEDs, and not the actual limit to the motion controller. Table 6 shows the DIP switch setting for the Limit Status LED polarity selection.

Table 6. Limit Status LED DIP Switch Settings

Axis 2 Switch Setting	Operation
	Active-high
	Active-low (factory default)

Back Panel Connector Wiring

Motor Power Terminal Blocks

Each axis on the MID-7604/7602 has a separate 5-position removable screw terminal block for motor power wiring. Figure 5 shows a typical stepper motor configuration pin assignment.



Note The dotted loop indicates a shielded cable. A line above a signal indicates that the signal is active-low.

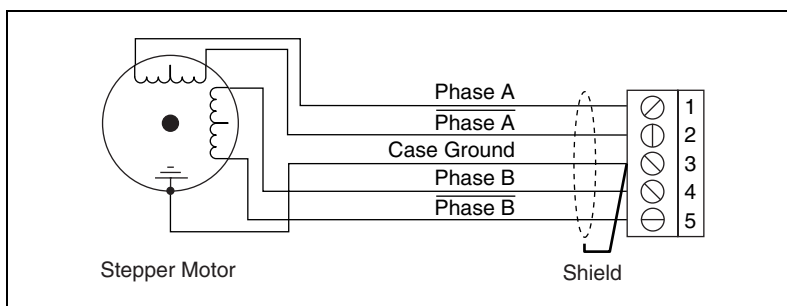

Figure 5. Typical Full-Coil Stepper Motor (2-Phase Type) Terminal Block Pin Assignment



Warning The stepper motor connectors on this drive are energized when the unit is powered on. Disconnect the MID-7604/7602 unit from the power outlet *before* connecting wires to or disconnecting wires from the stepper connectors. Strip back the insulation of the stepper wires to the stepper connectors no more than 7 mm. ***Failure to do so could result in electric shock leading to serious bodily injury or death.***

Use shielded, 20 AWG wire or larger for the motor power cable. If available, you should connect a case ground wire to pin 3 (Ground/Shield) to avoid ground loops and signal noise problems. Case ground connects to the motor housing, and not to the motor power terminals.

The MID-7604/7602 contains bipolar chopper drivers. You must wire the stepper motors in a 4-wire configuration as shown in Figure 5. You must isolate unused lead wires and leave them disconnected. Refer to the

Stepper Motor Configurations section of this guide for additional information on connecting 6- and 8-wire motors and on the alternate half-coil configuration.



Caution Never connect unused center taps or winding terminals to pin 3 (ground) or to each other.

Encoder Terminal Blocks

For quadrature incremental encoder signals, each MID-7604/7602 axis has a separate 8-position removable screw terminal block. Where applicable, the MID-7604/7602 accepts two types of encoder signal inputs: single-ended (TTL) or differential line driver. You can accommodate open-collector output encoders by using 2.2 k Ω pullup resistors to +5 VDC.

Figure 6 shows the typical encoder wiring pin assignment for single-ended signal input.

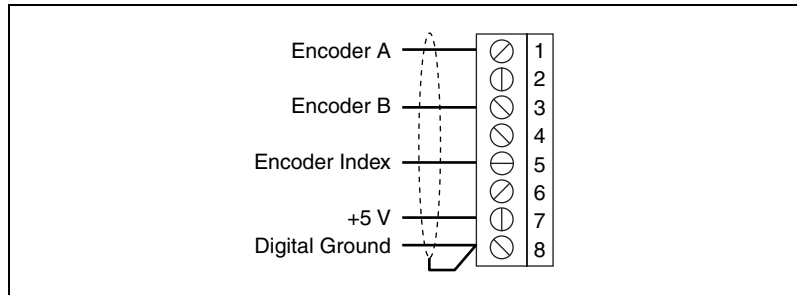

Figure 6. Typical Single-Ended Encoder Wiring Pin Assignment

Figure 7 shows the typical encoder wiring pin assignment for differential line driver signal inputs.

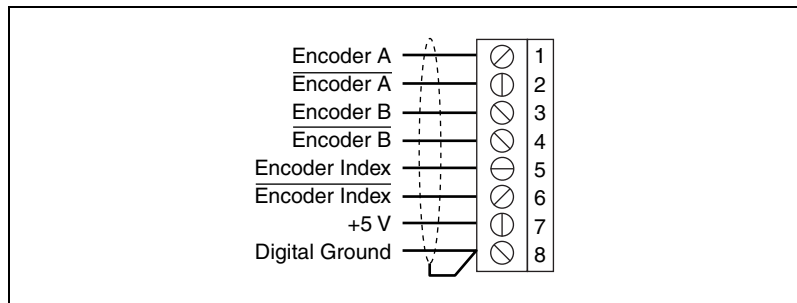

Figure 7. Typical Differential Line Driver Encoder Wiring Pin Assignment

If the encoder cable length is greater than 10 ft, use encoders with line driver outputs for your applications. Power for a +5 V encoder—generated by a power supply inside the MID-7604/7602—is available on pin 7.



Note If you require other encoder power voltages, reference an external power supply to the Digital Ground signal on the 8-pin encoder terminal block.

The MID-7604/7602 supports differential inputs for Phase A, Phase B, and Index signals. You can easily accommodate encoders with various phase relationships by swapping the signals and/or connecting them to the inverting inputs as specific applications require. The Index signal must occur when both Phase A and Phase B signals are low, as shown in Figure 8. If the Index polarity is inverted, try reversing the Index and $\overline{\text{Index}}$ signals on differential encoders or using the $\overline{\text{Index}}$ input on single-ended encoders.

Figure 8 shows the proper encoder phasing for CW (forward) motor rotation.

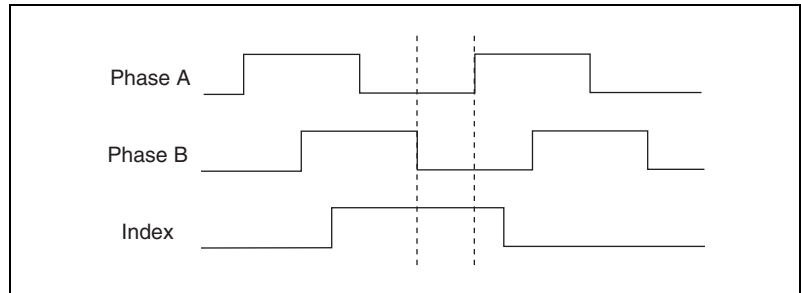

Figure 8. Encoder Signal Phasing, CW Rotation

Closed-loop stepper applications require consistent directional polarity between the motor and encoder for correct operation. The National Instruments motion control standard directional polarity is as follows:

- Positive = forward = clockwise (CW) facing motor shaft
- Negative = reverse = counter-clockwise (CCW) facing motor shaft

Figure 9 shows clockwise and counter-clockwise motor rotation.

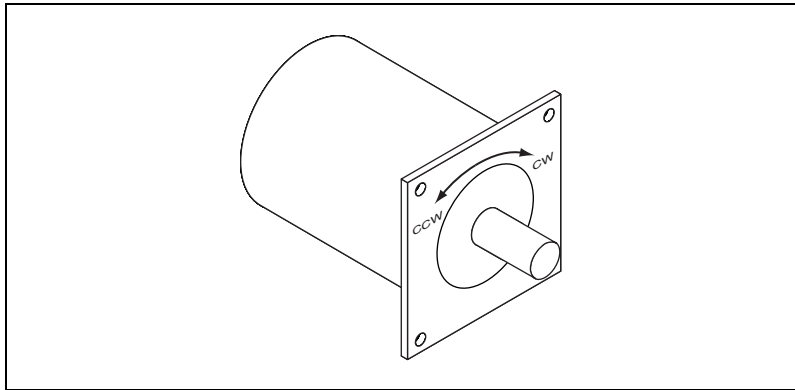

Figure 9. Clockwise and Counter-Clockwise Motor Rotation

When connecting the encoder wiring to your MID-7604/7602, use shielded wire of at least 24 AWG. Analog noise filters filter the encoder inputs in the MID-7604/7602. You must use cables with twisted pairs and an overall shield for improved noise immunity and enhanced encoder signal integrity. Figure 10 shows twisted pairs in a shielded cable.

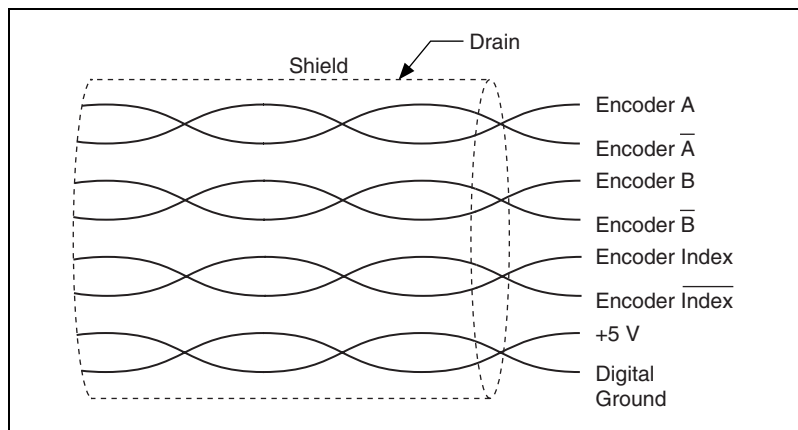

Figure 10. Shielded Twisted Pairs



Note If you use an unshielded cable, noise can corrupt the encoder signals, resulting in lost counts, reduced accuracy, and other erroneous encoder and controller operation.

Limit Switch Terminal Blocks

For end-of-travel limit, home, inhibit input, and inhibit output connections, MID-7604/7602 axes have a separate, 6-position removable screw terminal connector block. Figure 11 shows the limit switch terminal block pin assignments.

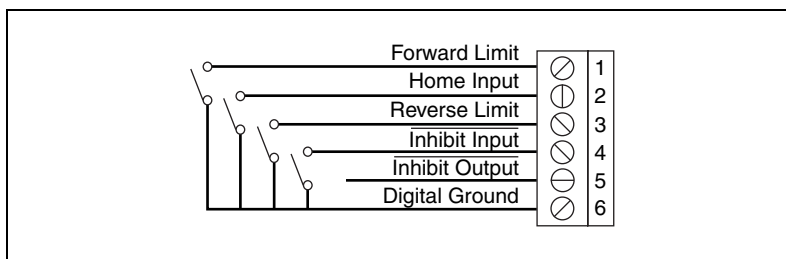

Figure 11. Limit Switch Terminal Block Pin Assignment
(Passive Limit Switch Connection Example)

The inhibit output signal is asserted low from the MID-7604/7602 when an axis is inhibited. This signal can be useful for actuating mechanical brakes or for monitoring an axis status. An axis is inhibited if the host bus interlock circuitry is activated, if the ENABLE switch on the front panel is in the inhibit position, if the motion controller's inhibit signal is low, or if the per-axis inhibit input is actively driven.

The MID-7604/7602 stepper drive remains in a reset state for 500 ms after the inhibit is deasserted. Therefore, you can lose steps if you attempt to issue a start motion command within 500 ms from the deassertion of the stepper drive inhibit. A Kill command asserts the inhibit signal from the controller and a Halt command deasserts the inhibit signal from the controller. The yellow LEDs (middle row) on the front panel illuminate if an axis is currently inhibited (killed state). Execute a halt stop to de-assert the inhibit signal from the controller, after which you must wait at least 500 ms before executing a start.

Breakpoint and Trigger Terminal Blocks

Both the breakpoint and trigger connectors use a 6-pin removable terminal block.

The trigger terminal block provides access to the trigger input lines, shutdown input line, and digital ground. The breakpoint terminal block provides access to the breakpoint output lines, +5 V supplied by the MID-7604/7602, and digital ground. Figures 12 and 13 show the breakpoint and trigger 6-position terminal block assignments.

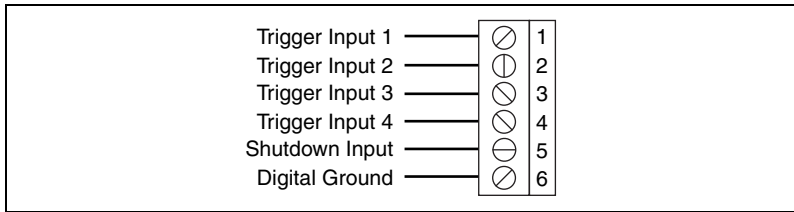

Figure 12. Trigger Terminal Block Pin Assignment

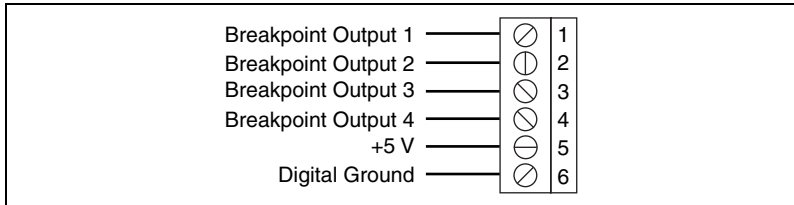

Figure 13. Breakpoint Terminal Block Pin Assignment

Analog I/O Terminal Blocks

The MID-7604/7602 has two analog I/O connectors. The analog input connector uses a 6-pin removable terminal block, and the analog output connector uses a 5-pin removable terminal block.

The analog input terminal block provides access to four analog-to-digital converter channels, an analog reference voltage from the converter circuit, and an analog input ground signal. The analog output terminal block provides access to four digital-to-analog converter channels with ± 10 V output range and analog output ground. Refer to Figures 14 and 15 for terminal block pin assignments.

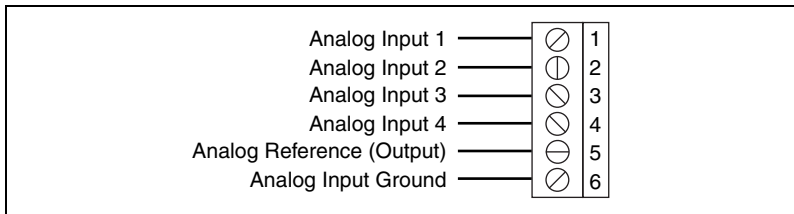

Figure 14. Analog Input Terminal Block Pin Assignment

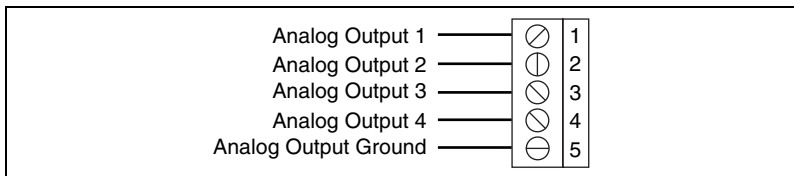

Figure 15. Analog Output Terminal Block Pin Assignment

Accessories for Optional Use

Strain-Relief Bar

The strain-relief bar provides strain relief for wiring to the back panel terminals of the MID-7604/7602.

The arms of the strain-relief bar attach to the sides of the MID-7604/7602 with the thumb nuts facing upward, as shown in Figure 16.

Using the provided screws, attach the strain-relief bar to the rear set of screwholes on the side panels of the MID-7604/7602.

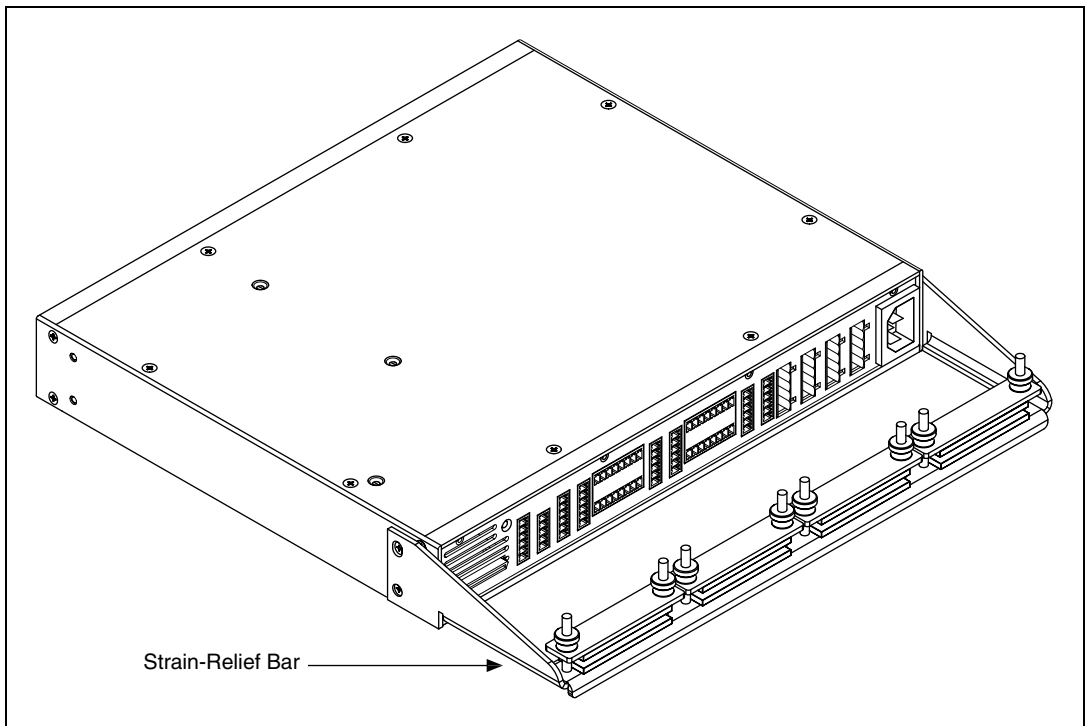

Figure 16. MID-7604/7602 with the Strain-Relief Bar Installed

Panel-Mount Kit (Included)

The panel-mount kit allows you to mount the MID-7604/7602 inside a cabinet or enclosure. Using the provided screws, attach the panel-mount kit to the rear and front set of screw holes on the side panels of the MID-7604/7602, as shown in Figure 17.

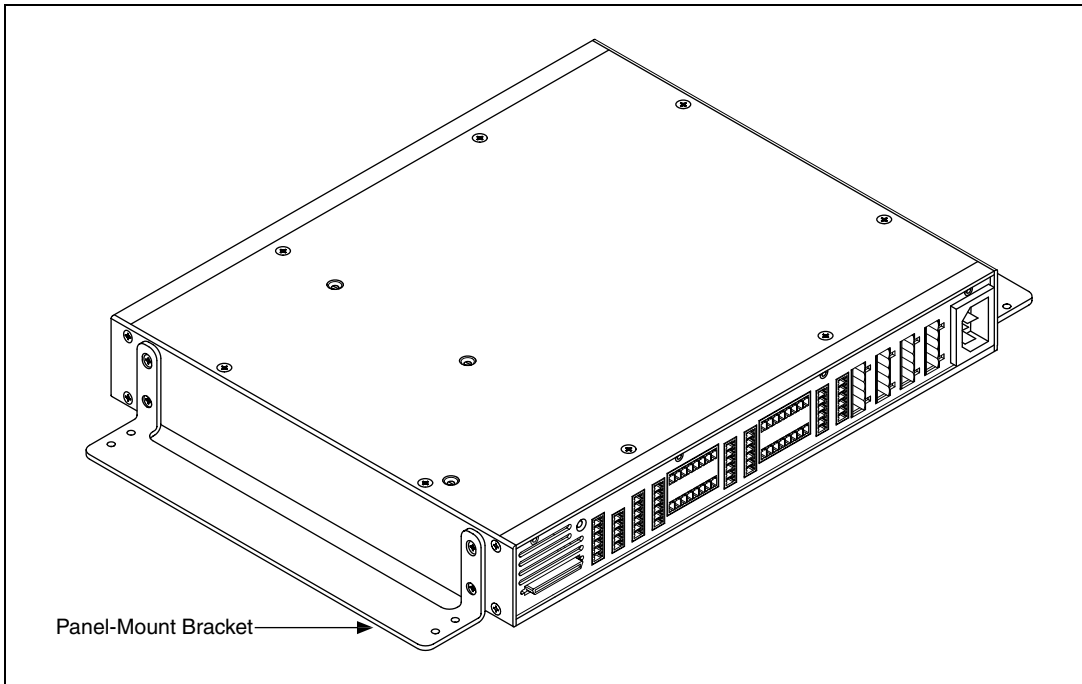

Figure 17. MID-7604/7602 with the Panel-Mount Kit Installed



Note The strain-relief bar and panel-mount kit cannot be installed at the same time.

Amplifier/Driver Command Signals

For stepper drivers, the two industry standards for command signals are as follows:

- Step and Direction signals (MID-7604/7602 standard)
- Independent CW and CCW pulses

The MID-7604/7602 uses stepper drivers that have active-high step and direction inputs. You must configure the stepper outputs of your motion controller for Step and Direction signals with active-high polarity.



Note You can use National Instruments Measurement & Automation Explorer (MAX) to configure the stepper polarity for your NI motion controller.

Stepper Motor Configurations

This section describes the various industry-standard winding configurations for stepper motors and shows how to connect them to a MID-7604/7602. The MID-7604/7602 is compatible with all configurations of two-phase stepper motors.



Note The MID-7604/7602 is *not* compatible with 5-lead unipolar stepper motors or 5-phase stepper motors.

2-phase stepper motors come in 4-, 6-, and 8-wire variations. Figure 18 shows a 6-wire and an 8-wire stepper motor. A 4-wire motor is the same as a 6-wire motor except that the center taps (CT) are not brought out.

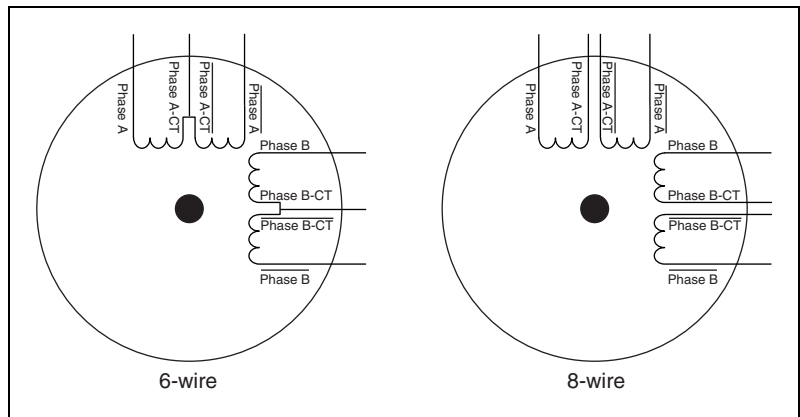

Figure 18. 6-Wire and 8-Wire Stepper Motors

For maximum flexibility, you can connect 8-wire stepper motors in either a series or parallel configuration. Connecting the windings in a series, as shown in Figure 19, produces the most torque per amp but has the disadvantage of higher inductance and poorer high-speed performance.

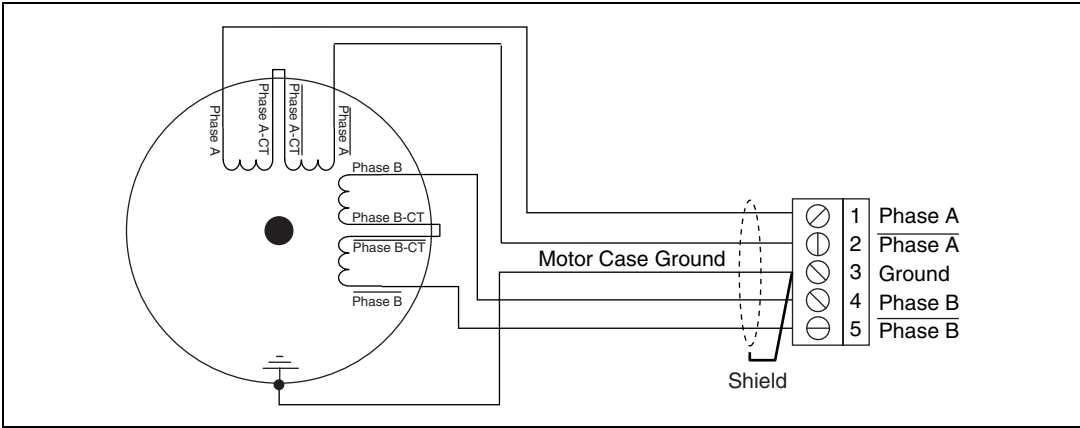

Figure 19. Series Stepper Motor Wiring (Higher Torque, Lower Speed)

Alternatively, you can wire 8-wire stepper motors in parallel as shown in Figure 20. This configuration produces better high-speed performance but requires more current to produce rated torque.

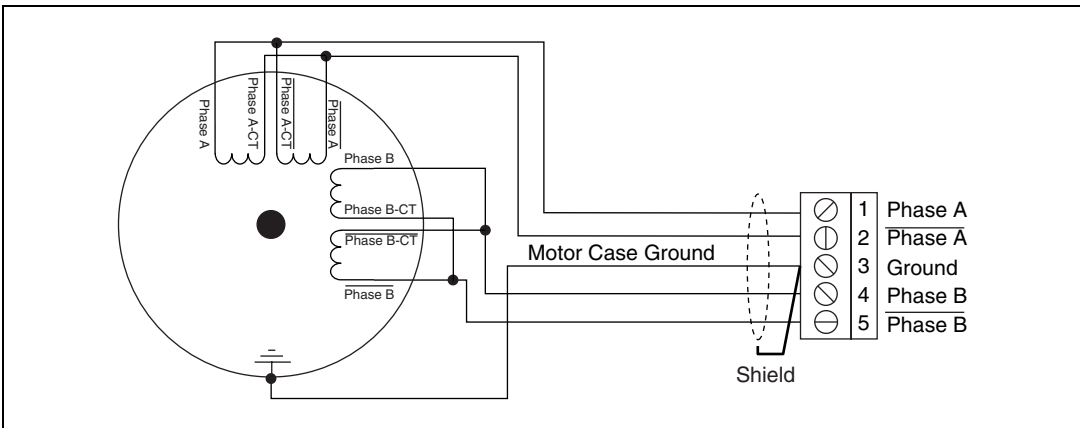

Figure 20. Parallel Stepper Motor Wiring (Higher Speed, Lower Torque)

Notice that an 8-wire motor wired in series is virtually identical to a 6-wire motor and typically has the same high-torque but low-speed characteristics. While a parallel configuration is not possible with a 6-wire motor, you can usually obtain high-speed performance with the half-coil connection shown in Figure 21. This configuration sacrifices low-speed torque for better high-speed performance. With this configuration, it is typically not possible to produce the rated torque of the motor without the risk of the motor overheating because only half of the windings are being used.

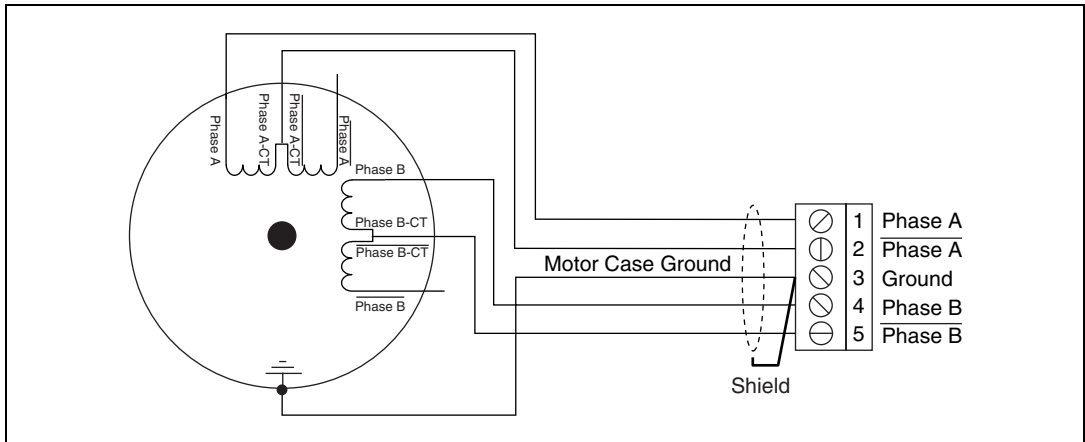

Figure 21. Half-Coil Stepper Motor Wiring

Figure 22 shows the wiring for a typical 4-wire motor.

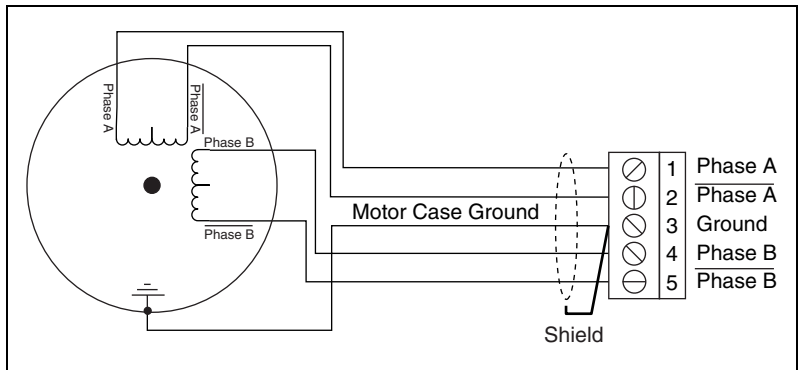

Figure 22. 4-Wire Motor Wiring

Specifications

The following specifications apply only to the MID-7604/7602. To obtain a complete system specification, you must account for your motion controller. Refer to your controller specifications to determine overall system specifications.

Some signals have compatibility defined as signal pass-through, which means the MID-7604/7602 may have passive filtering on these signals but will not affect the voltage range or current handling capability. Consult your motion controller specifications to determine the allowable voltage range and logic level compatibility of the signal.

Stepper Amplifiers

Type	IM481H modular hybrid, bipolar chopper
Chopping frequency	20 kHz
DC-bus motor	24 VDC nominal
Current per phase	0.20–1.4 A peak (0.14–1 A RMS) (factory setting is 0.50 A peak)
Microstepping selections	×2, 4, 8, 16, 32, 64, 128, 256 ×5, 10, 25, 50, 125, 250 (factory default is ×10 microsteps/step)
Continuous power output rating (all axes combined).....	80 W continuous

Motion I/O

Encoder inputs	Quadrature, incremental
Voltage range.....	0–5 VDC
Differential input threshold	± 0.3 V (typical)
Single ended input threshold	TTL/CMOS
Noise filter (RC time constant).....	100 ns
Maximum quadrature frequency	1 MHz
Limit and home switch inputs	
Compatibility	Signal pass-through

Inhibit inputs

Voltage range	0–12 VDC
Inhibit low voltage	0.8 V
Inhibit high voltage	2 V

Inhibit output

Voltage range	0–5 VDC
Output low voltage	0.5 V at 64 mA
Output high voltage	2.4 V at 32 mA

Trigger input

Compatibility	Signal pass-through
Noise filter (RC time constant)	100 ns

Breakpoint output

Compatibility	Signal pass-through
---------------------	---------------------

Analog input

Compatibility	Signal pass-through
Noise filter (RC time constant)	10 μ s

Analog output

Compatibility	Signal pass-through
---------------------	---------------------

Shutdown input

Compatibility	Signal pass-through
---------------------	---------------------

+5 V output	1 A
-------------------	-----

Included Connectors

Encoders	8-position mini-combicon 3.81 mm plug (1 per axis)
Limits	6-position mini-combicon 3.81 mm plug (1 per axis)
Motors	5-position combicon 5.08 mm plug (1 per axis)
Breakpoints	6-position mini-combicon 3.81 mm plug (1 total)
Triggers	6-position mini-combicon 3.81 mm plug (1 total)

Analog input	6-position mini-combicon 3.81 mm plug (1 total)
Analog output	5-position mini-combicon 3.81 mm plug (1 total)
AC power.....	Detachable AC power cord (IEC standard type)
Motion I/O	68-pin female high density VHDCI type

Power Supply

Input voltage	115/230 VAC, 2/1 A, 60/50 Hz
Measurement category	II
Fuse	
115 VAC input (factory default)	F3A 250V (Bussmann #GMA-3)
230 VAC input	F1.5A 250V (Bussmann #GMA-1.5)
Dimensions	5 mm × 20 mm

Host Bus Voltage Interlock

Undervoltage threshold.....	4 VDC
-----------------------------	-------

Physical Characteristics

Dimensions (W × H × L)	25.4 cm × 4.3 cm × 30.7 cm (10 in. × 1.7 in. × 12.1 in.)
Weight	4.5 kg (10 lb.)

Environment

The MID-7604/7602 is intended for indoor use only.

Operating temperature 0 °C to 40 °C

Storage temperature -20 °C to 70 °C

Relative humidity 10% to 90%, noncondensing

Pollution Degree 2

Approved at altitudes up to 2,000 m.

Safety

This product is designed to meet the requirements of the following standards of safety for electrical equipment for measurement, control, and laboratory use:

- EN 61010-1, IEC 61010-1
- UL 508C, UL 61010-1
- CAN/CSA C22.2 No. 61010-1

UL Listed to UL 508C, power conversion equipment.



Note For UL and other safety certifications, refer to the product label or visit ni.com/certification, search by model number or product line, and click the appropriate link in the Certification column.

Electromagnetic Compatibility

Emissions EN 55011 Class A at 10 m
FCC Part 15A above 1 GHz

Immunity EN 61326:1997 + A2:2001,
Table 1

CE, C-Tick, and FCC Part 15 (Class A) Compliant



Note For EMC compliance, operate this device with shielded cabling. Refer to the Declaration of Conformity (DoC) for this product for any additional regulatory compliance information. To obtain the DoC for this product, visit ni.com/certification, search by model number or product line, and click the appropriate link in the Certification column.

Where to Go for Support

The National Instruments Web site is your complete resource for technical support. At ni.com/support you have access to everything from troubleshooting and application development self-help resources to email and phone assistance from NI Application Engineers.

A Declaration of Conformity (DoC) is our claim of compliance with the Council of the European Communities using the manufacturer's declaration of conformity. This system affords the user protection for electronic compatibility (EMC) and product safety. You can obtain the DoC for your product by visiting ni.com/certification. If your product supports calibration, you can obtain the calibration certificate for your product at ni.com/calibration.

National Instruments corporate headquarters is located at 11500 North Mopac Expressway, Austin, Texas, 78759-3504. National Instruments also has offices located around the world to help address your support needs. For telephone support in the United States, create your service request at ni.com/support and follow the calling instructions or dial 512 795 8248. For telephone support outside the United States, contact your local branch office:

Australia 1800 300 800, Austria 43 0 662 45 79 90 0,
Belgium 32 0 2 757 00 20, Brazil 55 11 3262 3599,
Canada (Calgary) 403 274 9391, Canada (Ottawa) 613 233 5949,
Canada (Québec) 450 510 3055, Canada (Toronto) 905 785 0085,
Canada (Vancouver) 604 685 7530, China 86 21 6555 7838,
Czech Republic 420 224 235 774, Denmark 45 45 76 26 00,
Finland 385 0 9 725 725 11, France 33 0 1 48 14 24 24,
Germany 49 0 89 741 31 30, India 91 80 51190000,
Israel 972 0 3 6393737, Italy 39 02 413091, Japan 81 3 5472 2970,
Korea 82 02 3451 3400, Malaysia 603 9131 0918,
Mexico 01 800 010 0793, Netherlands 31 0 348 433 466,
New Zealand 0800 553 322, Norway 47 0 66 90 76 60,
Poland 48 22 3390150, Portugal 351 210 311 210,
Russia 7 095 783 68 51, Singapore 65 6226 5886,
Slovenia 386 3 425 4200, South Africa 27 0 11 805 8197,
Spain 34 91 640 0085, Sweden 46 0 8 587 895 00,
Switzerland 41 56 200 51 51, Taiwan 886 2 2528 7227,
Thailand 662 992 7519, United Kingdom 44 0 1635 523545

National Instruments™, NI™, and ni.com™ are trademarks of National Instruments Corporation. Product and company names mentioned herein are trademarks or trade names of their respective companies. For patents covering National Instruments products, refer to the appropriate location: **Help»Patents** in your software, the `patents.txt` file on your CD, or ni.com/patents.