

# INSTALLATION GUIDE

# NI 8262

This document explains how to set up your NI 8262 expansion module.

## What You Need to Get Started

---

To set up and use your NI 8262 module, you need the following:

- A PXI Express chassis with at least one free PXI Express or hybrid slot.
- A MXI-Express x4 to x4 cable, or a MXI-Express x4 to x1 cable.



**Note** For maximum bandwidth, consult your PXIe chassis manual to ensure the slot you have selected supports x4 PCIe lane width.

- A downstream device—either an expansion chassis such as a PXI Express/CompactPCI Express (PXIe/cPCIe) chassis with an NI PXI-8372 in the controller slot, or another cabled PCI express device such as the NI RAID solution.



**Note** Your NI 8262 card will work in any standard peripheral slot of a CompactPCI Express chassis adhering to the *PICMG CompactPCI Express EXP.0 R1.0* specification, or in a peripheral slot of a PXI Express chassis that is compatible with the *PXI Express Hardware Specification, Revision 1.0* or later.

## Unpacking

---

Your NI 8262 card is shipped in an antistatic package to prevent electrostatic discharge (ESD) to the devices. ESD can damage several components on the device.



**Caution** *Never* touch the exposed pins of connectors. Doing so may damage the device.

To avoid such damage in handling the device, take the following precautions:

- Ground yourself by using a grounding strap or by holding a grounded object.
- Touch the antistatic package to a metal part of the computer chassis before removing the device from the package.

Remove the device from the package and inspect the device for loose components or any sign of damage. Notify NI if the device appears damaged in any way. Do *not* install a damaged device into the PXI Express/CompactPCI Express chassis.

Store the device in the antistatic envelope when not in use.

## Installing an NI 8262

---

Complete the following steps to install the NI 8262 in your PXI Express or CompactPCI Express chassis.

1. Power off your PXI Express or CompactPCI Express chassis, but leave it plugged in while installing the NI 8262. The power cord grounds the chassis and protects it from electrical damage while you install the module.



**Note** The NI 8262 must be installed in a PXIe or hybrid peripheral slot. Consult your PXI chassis manual for the location of these slots.



**Caution** To protect both yourself and the chassis from electrical hazards, leave the chassis off until you finish installing the NI 8262.

2. Unscrew and remove any metal slot covers to the slot in which you intend to install the NI 8262.
3. Touch a metal part of the chassis to discharge any static electricity that might be on your clothes or body.
4. Make sure the injector/ejector handle is in its downward position. Be sure to remove all connector packaging and protective caps from retaining screws on the module. Align the NI 8262 with the card guides on the top and bottom of the peripheral slot.



**Caution** Do *not* raise the injector/ejector handle as you insert the NI 8262. It will not insert properly unless the handle is in its downward position so that it does not interfere with the injector/ejector rail on the chassis, as shown in Figure 1.

5. Hold the handle as you slowly slide the module into the chassis until the handle catches on the injector/ejector rail.
6. Raise the injector/ejector handle until the module firmly seats into the backplane receptacle connectors. The front panel of the NI 8262 should be even with the front panel of the chassis.



**Note** There are LEDs on the PCB that may light up when the board is plugged in. They indicate connection status and lane activity. To determine the meaning of the LED light patterns for the Link and PWR LEDs on the front panel, refer to Table 1.

7. Tighten the bracket-retaining screws on the top and bottom of the front panel to secure the NI 8262 to the chassis.

Figure 1 shows an NI 8262 just before installation in the system controller slot of a National Instruments chassis.

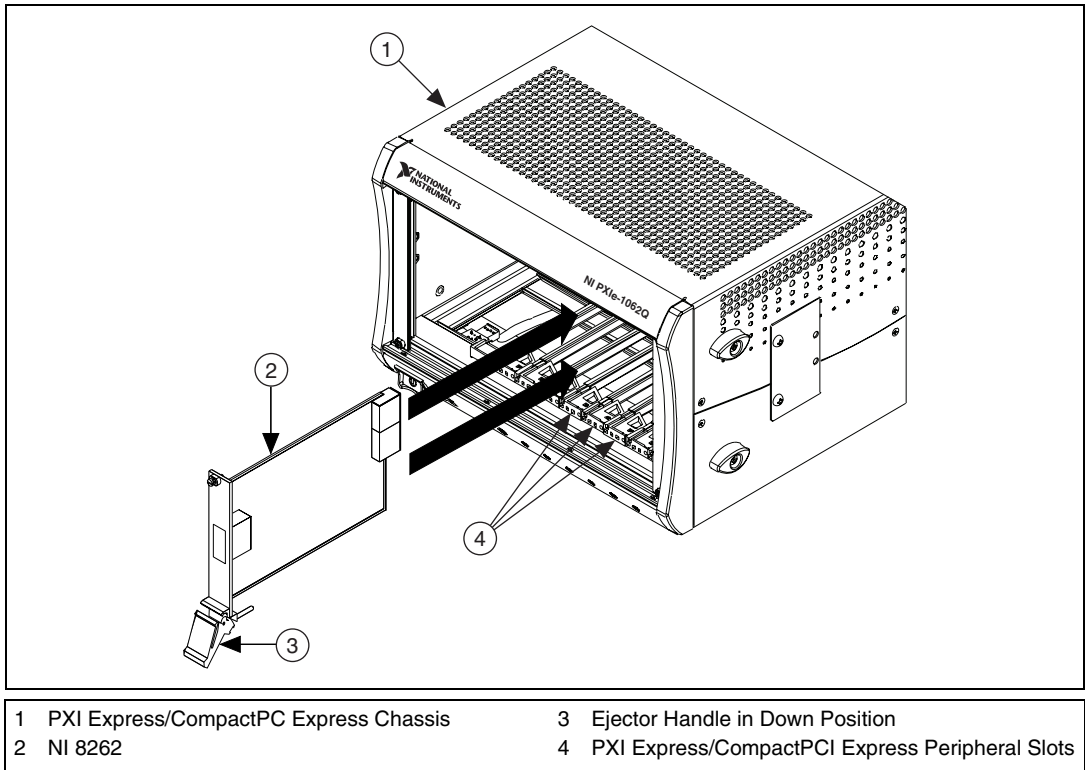

**Figure 1.** NI 8262 Card Installation

# Cabling

---

Connect the NI 8262 to the downstream device with the x4 PCIe cable. The x4 cables have no polarity, so either end may be connected to either card. The x4 to x1 cable adapter will only fit in with the x4 connected to the NI 8262.



**Caution** Do not remove the cable after the system is powered on. Doing so can cause the system to bluescreen, hang, or data loss/corruption. If a cable becomes unplugged, plug it back into the system. You must reboot before you can continue using your hardware.

## Powering On the System

---

Complete the following steps to power on the system.

1. Power on all of the downstream devices in any order you choose.
2. Power on the PXIe/cPCIe system.

Typically, PCI-PCI bridges and switches are used to add PCI devices to a PCI hierarchy in which all the bridges and devices are contained within a single chassis. Because of this, BIOSes and operating systems make the assumption that all PCI devices in the entire hierarchy will be available as soon as code execution begins at power-up time. This assumption means that all of the expansion chassis must be turned on before the host PC for the BIOS and OS to correctly configure a cabled PXI Express system.



**Note** There are no requirements on how MXI-Express expansion chassis are powered up relative to each other, as long as they are all on before the host PXIe/cPCIe system is powered on.

## Checking LEDs for Status

---

After powering on the system, you should check the LEDs for status to ensure that all connected systems have linked. The following tables provide the meaning of the LEDs.

**Table 1.** NI 8262 Front Panel LED Values

LED	Color	Meaning
PWR	Off	No power
	Red, blinking	Power is out of spec
	Green	Power is within spec

**Table 1.** NI 8262 Front Panel LED Values (Continued)

LED	Color	Meaning
LINK	Red	Link not established
	Green	Link established
	Off	No power

## Specifications

This section provides specifications for the NI 8262 module, including electrical, physical, compliance, and safety information.

### Electrical

Voltage (V)	Current (Amps)	
	Typical	Maximum
+3.3 V	1.80	3.90

### Physical

Board dimensions.....	Single slot 3U PXI Express or Compact PCI Express module, 100 mm × 175 mm
Slot requirements .....	One peripheral slot supporting a x4 PCIe connection (either PXIe or hybrid slot)
Compatibility .....	Fully compatible with <i>PXI Express Specification 1.0</i> , and <i>CompactPCI Express Specification 1.0</i>
Weight.....	0.14 Kg (4.75 lb) typical

### Environment

Maximum altitude .....	2,000 m (800 mbar) (at 25 °C ambient temperature)
Pollution Degree .....	2
Indoor use only.	



**Caution** Clean the NI 8262 with a soft nonmetallic brush. Make sure that the device is completely dry and free from contaminants before returning it to service.

## Operating Environment

Ambient temperature range .....0 to 55 °C (Tested in accordance with IEC-60068-2-1 and IEC-60068-2-2. Meets MIL-PRF-28800F Class 3 low temperature limit and MIL-PRF-28800F Class 2 high temperature limit.)

Relative humidity range.....10% to 90%, noncondensing (Tested in accordance with IEC-60068-2-56.)



**Caution** The operating temperature must not be exceeded, even when used in a chassis with a higher temperature range.

## Storage Environment

Ambient temperature range .....-40 to 71 °C (Tested in accordance with IEC-60068-2-1 and IEC-60068-2-2. Meets MIL-PRF-28800F Class 3 low temperature limit MIL-PRF-28800F Class 3 high temperature limit.)

Relative humidity range.....5% to 95% noncondensing (Tested in accordance with IEC-60068-2-56.)

## Shock and Vibration

Operating Shock .....30 g peak, half-sine, 11 ms pulse (Tested in accordance with IEC-60068-2-27. Meets MIL-PRF-28800F Class 2 limits.)

## Random Vibration

Operating .....	5 to 500 Hz, 0.3 g <sub>rms</sub> (with solid-state hard drive)
Nonoperating .....	5 to 500 Hz, 2.4 g <sub>rms</sub> (Tested in accordance with IEC-60068-2-64. Nonoperating test profile exceeds the requirements of MIL-PRF-28800F, Class 3.)



**Note** Specifications are subject to change without notice.

## Safety

This product is designed to meet the requirements of the following standards of safety for electrical equipment for measurement, control, and laboratory use:

- IEC 61010-1, EN-61010-1
- UL 61010-1, CSA 61010-1



**Note** For UL and other safety certifications, refer to the product label or visit [ni.com/certification](http://ni.com/certification), search by model number or product line, and click the appropriate link in the Certification column.

## Electromagnetic Compatibility

This product is designed to meet the requirements of the following standards of EMC for electrical equipment for measurement, control, and laboratory use:

- EN 61326 EMC requirements; Minimum Immunity
- EN 55011 Emissions; Group 1, Class A
- CE, C-Tick, ICES, and FCC Part 15 Emissions; Class A



**Note** For EMC compliance, operate this device according to product documentation.

## CE Compliance

This product meets the essential requirements of applicable European Directives, as amended for CE marking, as follows:

- 2006/95/EC; Low-Voltage Directive (safety)
- 2004/108/EC; Electromagnetic Compatibility Directive (EMC)



**Note** Refer to the Declaration of Conformity (DoC) for this product for any additional regulatory compliance information. To obtain the DoC for this product, visit [ni.com/certification](http://ni.com/certification), search by model number or product line, and click the appropriate link in the Certification column.

## Environmental Management

National Instruments is committed to designing and manufacturing products in an environmentally responsible manner. NI recognizes that eliminating certain hazardous substances from our products is beneficial not only to the environment but also to NI customers.

For additional environmental information, refer to the *NI and the Environment* Web page at [ni.com/environment](http://ni.com/environment). This page contains the environmental regulations and directives with which NI complies, as well as other environmental information not included in this document.

## Waste Electrical and Electronic Equipment (WEEE)



**EU Customers** At the end of their life cycle, all products *must* be sent to a WEEE recycling center. For more information about WEEE recycling centers and National Instruments WEEE initiatives, visit [ni.com/environment/weee.htm](http://ni.com/environment/weee.htm).

## 电子信息产品污染控制管理办法（中国 RoHS）



**中国客户** National Instruments 符合中国电子信息产品中限制使用某些有害物质指令 (RoHS)。关于 National Instruments 中国 RoHS 合规性信息，请登录 [ni.com/environment/rohs\\_china](http://ni.com/environment/rohs_china)。(For information about China RoHS compliance, go to [ni.com/environment/rohs\\_china](http://ni.com/environment/rohs_china).)

National Instruments, NI, ni.com, and LabVIEW are trademarks of National Instruments Corporation. Refer to the *Terms of Use* section on [ni.com/legal](http://ni.com/legal) for more information about National Instruments trademarks. Other product and company names mentioned herein are trademarks or trade names of their respective companies. For patents covering National Instruments products, refer to the appropriate location: **Help»Patents** in your software, the `patents.txt` file on your CD, or [ni.com/patents](http://ni.com/patents).