

# INSTALLATION GUIDE

# HDD-8263/8264

This guide describes the HDD-8263 and HDD-8264 products, lists what you need to get started, and explains how to set up and get started with your hardware.

## Contents

---

Safety Information .....	2
Rack Mount Safety Information .....	4
Sicherheitshinweise.....	5
Sicherheitshinweise zum Einbau in Gestellrahmen.....	7
Introduction .....	8
About the HDD-826x Series .....	8
Description and Features .....	8
HDD-8263 x4 System .....	8
HDD-8264 x4 System .....	8
What You Need to Get Started .....	9
Unpacking .....	9
Hardware Installation and Use .....	10
Hardware Installation for x4 PXIe Solution .....	10
Installing an NI 8262 .....	10
Cabling.....	11
Powering Up the HDD-826x for PXI Express System.....	11
Driver Installation.....	11
Powering Down the HDD-826x for PXI Express System.....	11
Reconfiguring the RAID Arrays of the HDD-826x for PXI Express Systems .....	12
Hardware Overview .....	12
Functional Overview.....	12
LED Indicators.....	13
Cable Options .....	14
Specifications .....	14
Physical.....	14
Environment.....	14
Operating Environment .....	15
Storage Environment .....	15
Cleaning .....	15
Safety .....	15

Electromagnetic Compatibility.....	15
CE Compliance.....	16
Environmental Management .....	16
Compliance with FCC/Canada Radio Frequency Interference	
Regulations .....	17
Determining FCC Class.....	17
FCC/DOC Warnings .....	17
Class A.....	18
Federal Communications Commission .....	18
Canadian Department of Communications .....	18
Compliance with EU Directives.....	18
Where to Go for Support .....	19
Important Information .....	20

## Safety Information

---

The following section contains important safety information that you *must* follow when installing and using the module.

Do *not* operate the module in a manner not specified in this document. Misuse of the module can result in a hazard. You can compromise the safety protection built into the module if the module is damaged in any way. If the module is damaged, return it to National Instruments for repair.

Do *not* substitute parts or modify the module except as described in this document. Use the module only with the chassis, modules, accessories, and cables specified in the installation instructions. You *must* have all covers and filler panels installed during operation of the module.

Do *not* operate the module in an explosive atmosphere or where there may be flammable gases or fumes. If you must operate the module in such an environment, it must be in a suitably rated enclosure.

Clean the module with a soft, nonmetallic brush. Make sure that the module is completely dry and free from contaminants before returning it to service.

To avoid risk of explosion, use only the correct type of replacement batteries. Dispose of used batteries according to the instructions.

Operate the module only at or below Pollution Degree 2. Pollution is foreign matter in a solid, liquid, or gaseous state that can reduce dielectric strength or surface resistivity. The following is a description of pollution degrees:

- Pollution Degree 1 means no pollution or only dry, nonconductive pollution occurs. The pollution has no influence.

- Pollution Degree 2 means that only nonconductive pollution occurs in most cases. Occasionally, however, a temporary conductivity caused by condensation must be expected.
- Pollution Degree 3 means that conductive pollution occurs, or dry, nonconductive pollution occurs that becomes conductive due to condensation.

You *must* insulate signal connections for the maximum voltage for which the module is rated. Do *not* exceed the maximum ratings for the module. Do not install wiring while the module is live with electrical signals. Do not remove or add connector blocks when power is connected to the system. Avoid contact between your body and the connector block signal when hot swapping modules. Remove power from signal lines before connecting them to or disconnecting them from the module.

Operate the module at or below the *measurement category*<sup>1</sup> marked on the hardware label. Measurement circuits are subjected to *working voltages*<sup>2</sup> and transient stresses (overvoltage) from the circuit to which they are connected during measurement or test. Measurement categories establish standard impulse withstand voltage levels that commonly occur in electrical distribution systems. The following is a description of measurement categories:

- Measurement Category I is for measurements performed on circuits not directly connected to the electrical distribution system referred to as MAINS<sup>3</sup> voltage. This category is for measurements of voltages from specially protected secondary circuits. Such voltage measurements include signal levels, special equipment, limited-energy parts of equipment, circuits powered by regulated low-voltage sources, and electronics.
- Measurement Category II is for measurements performed on circuits directly connected to the electrical distribution system (MAINS<sup>3</sup>). This category refers to local-level electrical distribution, such as that provided by a standard wall outlet (for example, 115 AC voltage for U.S. or 230 AC voltage for Europe). Examples of Measurement Category II are measurements performed on household appliances, portable tools, and similar modules.
- Measurement Category III is for measurements performed in the building installation at the distribution level. This category refers to measurements on hard-wired equipment such as equipment in fixed installations, distribution boards, and circuit breakers. Other examples

---

<sup>1</sup> Measurement categories, also referred to as *installation categories*, are defined in electrical safety standard IEC 61010-1.

<sup>2</sup> Working voltage is the highest rms value of an AC or DC voltage that can occur across any particular insulation.

<sup>3</sup> MAINS is defined as a hazardous live electrical supply system that powers equipment. Suitably rated measuring circuits may be connected to the MAINS for measuring purposes.

are wiring, including cables, bus bars, junction boxes, switches, socket outlets in the fixed installation, and stationary motors with permanent connections to fixed installations.

- Measurement Category IV is for measurements performed at the primary electrical supply installation (<1,000 V). Examples include electricity meters and measurements on primary overcurrent protection devices and on ripple control units.

## Rack Mount Safety Information



**Caution** Due to the device weight, two people should work together to mount the device in a rack.



**Caution** Install the unit as low as possible in the rack to maintain a lower center of gravity and prevent the rack from tipping when moved.

Follow these safety guidelines when installing the device in a rack:

- **Elevated Operating Ambient**—If installed in a closed or multi-unit rack assembly, the operating ambient temperature of the rack environment may be greater than room ambient temperature. Therefore, you should install the equipment in an environment compatible with the maximum ambient temperature ( $T_{ma}$ ) of 40 °C.
- **Reduced Air Flow**—When installing the equipment in a rack or cabinet, do not compromise the amount of airflow required for safe operation of the equipment.
- **Mechanical Loading**—When mounting the equipment in the rack or cabinet, avoid uneven mechanical loading that could create a hazardous condition.
- **Circuit Overloading**—When connecting the equipment to the supply circuit, avoid overloading the circuits. Refer to equipment nameplate ratings to avoid damaging over current protection and supply wiring.
- **Reliable Earthing**—Maintain reliable earthing of rack-mounted equipment, especially when using supply connections other than direct connections to the branch circuit (for example, power strips).
- **Redundant Power Supplies**—Where redundant power supplies are provided with the equipment, connect each power supply to a separate circuit to optimize the equipment redundancy.
- **Servicing**—Prior to servicing the equipment, disconnect all power supplies.

# Sicherheitshinweise

---

Im folgenden Abschnitt finden Sie wichtige Sicherheitshinweise, die beim Einbau und bei der Verwendung des Geräts unbedingt zu befolgen sind.

Es sind keine Abweichungen von den nachfolgenden Richtlinien zulässig. Beim falschen Umgang mit dem Gerät kann es zu Schäden kommen. Bei einem defekten Gerät sind die eingebauten Schutzvorrichtungen unter Umständen nicht mehr wirksam. Alle defekten Geräte sollten daher an National Instruments zurückgesendet und umgetauscht werden.

Soweit nicht anders beschrieben, dürfen keine Veränderungen am Gerät vorgenommen werden. Das Gerät darf nur zusammen mit den in der Installationsanleitung aufgeführten Chassis, Modulen, Kabeln und Zubehörteilen genutzt werden. Beim Betrieb des Geräts müssen alle Blenden und Abdeckungen angebracht sein.

Das Gerät darf nicht an Orten genutzt werden, an denen Explosionsgefahr besteht oder an denen entzündliche Gase oder Dämpfe auftreten können. Kann auf den Einsatz an einem solchen Ort nicht verzichtet werden, muss das Gerät mit einem vorschriftsmäßigen Schutzgehäuse versehen werden.

Das Gerät sollte mit einer weichen, nicht metallischen Bürste gereinigt werden. Bevor das Gerät nach der Reinigung wieder eingesetzt wird, muss es vollständig trocken und frei von Verschmutzungen sein.

Wenn die Batterien ersetzt werden müssen, sind stets die vorgeschriebenen Batterietypen zu verwenden. Falsche Batterietypen erhöhen die Explosionsgefahr. Die alten Batterien sind wie beschrieben zu entsorgen.

Das Gerät sollte in einer Umgebung verwendet werden, die maximal den Verschmutzungsgrad 2 aufweist. Als Verschmutzung gelten alle flüssigen, festen und gasförmigen Fremdstoffe, die die Leitfähigkeit der ansonsten nicht leitenden Oberfläche erhöhen können. Nachfolgend sind alle Verschmutzungsgrade im Einzelnen beschrieben:

- Verschmutzungsgrad 1 bedeutet keine Verschmutzung oder geringe Verschmutzung durch trockene, nicht leitende Partikel. Diese Kategorie hat keinen Einfluss auf das Gerät.
- Verschmutzungsgrad 2 bedeutet, dass die meisten Schmutzpartikel nicht leitend sind. Bisweilen muss jedoch mit Kriechströmen durch Kondenswasser gerechnet werden.
- Verschmutzungsgrad 3 bedeutet, dass die Schmutzpartikel selbst oder in Verbindung mit Kondenswasser Kriechströme verursachen können.

Alle angeschlossenen Leitungen, an denen die maximale Eingangsspannung für das Gerät zu erwarten ist, *müssen* isoliert sein. Die maximal zulässigen Eingangswerte des Geräts dürfen auf keinen Fall überschritten werden. Stellen Sie keine Verbindungen her, während das Gerät in Betrieb ist. Solange das Gerät an ein Netzteil angeschlossen ist, dürfen keine Anschlussblöcke eingesteckt oder herausgezogen werden. Wenn Sie Geräte ohne Ausschalten des Chassis austauschen müssen, achten Sie darauf, dass Sie nicht mit dem Anschlussblock in Berührung kommen. Trennen Sie alle Leitungen zunächst von der Signalquelle, bevor Sie sie vom Gerät trennen oder an das Gerät anschließen.

Das Gerät darf maximal in der *Messkategorie*<sup>1</sup> betrieben werden, die auf dem Etikett verzeichnet ist. Jeder Messkreis hat eine bestimmte *Arbeitsspannung*<sup>2</sup>. Daneben können jedoch durch den Stromkreis, an den das Messgerät angeschlossen ist, vorübergehende Spitzen (Überspannungen) auftreten. Messkategorien stellen einen Standard für die Belastbarkeit auf Spannungsspitzen dar. Nachfolgend sind alle Messkategorien im Einzelnen beschrieben:

- Messkategorie I gilt für Messungen an Schaltungen, die nicht direkt mit dem Stromnetz<sup>3</sup> verbunden sind, also keine Netzspannung führen. In diese Kategorie fallen alle Spannungsmessungen in Nebenstromkreisen mit speziellen Schutzschaltungen. Dazu zählen Pegelmessungen sowie Messungen an speziellen Geräten, Bauteilen mit begrenzter Spannung, Schaltkreisen mit Niederspannungsquellen und elektronischen Schaltungen.
- Messkategorie II gilt für Messungen an Schaltungen, die direkt mit dem Stromnetz<sup>3</sup> verbunden sind. In diese Kategorie fallen alle ortsveränderlichen Elektroanschlüsse, z. B. Haushaltssteckdosen (230 V~). Zur Messkategorie II zählen beispielsweise Messungen an Haushaltsgeräten oder tragbaren Werkzeugen.
- Messkategorie III gilt für Messungen an Elektroinstallationen von Gebäuden. In diese Kategorie fallen alle Messungen an ortsfesten Elektroanlagen wie Verteilern oder Schutzschaltern. Zu dieser Kategorie zählen ebenfalls Elektrokabel, Stromschienen, Abzweigdosen, Schalter, Steckdosen ortsfester Elektroinstallationen sowie Elektromotoren, die fest an Elektroinstallationen angeschlossen sind.
- Messkategorie IV gilt für Messungen an Starkstromanlagen mit Nennspannungen bis 1000 V. In diese Kategorie fallen Stromzähler, Messungen an Starkstromsicherungen und Rundsteueranlagen.

---

<sup>1</sup> Messkategorien (auch als *Installationskategorien* bezeichnet) sind im IEC-Standard 61010-1 bzw. der deutschen Entsprechung DIN EN 61010-1, "Sicherheitsbestimmungen für elektrische Mess-, Steuer-, Regel- und Laborgeräte", definiert.

<sup>2</sup> Die Arbeitsspannung ist die höchste zulässige Effektivspannung, für die die Isolierung ausgelegt sein muss.

<sup>3</sup> Das Stromversorgungsnetz ist definiert als Energieversorgungssystem für technische Geräte, das unter einer für den Menschen gefährlichen Spannung steht. An das Stromversorgungsnetz dürfen nur entsprechend ausgelegte Messgeräte und -leitungen angeschlossen werden.

# Sicherheitshinweise zum Einbau in Gestellrahmen



**Vorsicht!** Wegen seines Gewichts sollte das Gerät immer zu zweit in einen Gestellrahmen eingebaut werden.



**Vorsicht!** Bestücken Sie jeden Gestellrahmen von unten nach oben, so dass der Schwerpunkt des Rahmens möglichst tief liegt und er beim Anstoßen nicht umkippt.

Beim Einbau in einen Gestellrahmen sind folgende Sicherheitsrichtlinien zu befolgen:

- **Betriebstemperatur**—In einem geschlossenen Gestell oder einem Gestell für mehrere Geräte kann die Betriebstemperatur höher als die Umgebungstemperatur sein. Bauen Sie das Gerät daher nur dort ein, wo die maximale Umgebungstemperatur ( $t_{ma}$ ) 40 °C nicht übersteigt.
- **Belüftung**—Sorgen Sie beim Einbau in ein Gestell oder Gehäuse für genügend Belüftung, um den sicheren Betrieb des Geräts zu gewährleisten.
- **Lastverteilung**—Sorgen Sie beim Einbau in ein Gehäuse oder Gestell für gleichmäßige Lastverteilung.
- **Überlast**—Achten Sie beim Anschließen des Geräts an die Stromversorgung darauf, dass die maximal zulässigen Werte für Strom und Spannung nicht überschritten werden. Die technischen Daten finden Sie auf dem Etikett des Geräts. Bei Überlastung können die Überspannungsschaltung und die Kabel beschädigt werden.
- **Erdung**—Achten Sie darauf, dass alle in Gestelle eingebauten Geräte ordnungsgemäß geerdet sind. Das gilt insbesondere, wenn die Geräte nicht direkt an die Stromversorgung angeschlossen sind, sondern beispielsweise über Mehrfachsteckdosen).
- **Redundante Stromversorgung**—Wenn es für das Gerät mehrere Netzteile gibt, schließen Sie jedes Netzteil zur Steigerung der Ausfallsicherheit an einen separaten Stromkreis an.
- **Instandhaltung**—Alle Geräte sind vor der Instandhaltung von der Stromversorgung zu trennen.

# Introduction

---

The HDD-8263 and HDD-8264 series are applications of cabled PCI Express technology. These products leverage commercially available enterprise class RAID controllers and hard drives. For the remainder of this guide, the term *HDD-826x* refers to any product in the HDD-8263 or HDD-8264 series.

## About the HDD-826x Series

### Description and Features

The HDD-8263 is a 1U chassis specifically designed for RAID applications by National Instruments. This chassis supports up to four enterprise class SATA hard drives controlled by a four-port PCI Express hardware RAID controller. This system has been preconfigured as RAID 0; however, the system supports additional modes such as RAID 1, RAID 5, RAID 10, and JBOD. Refer to the included RAID controller user manual or guide for more information about these modes.

The HDD-8264 is a 2U chassis specifically designed for RAID applications by National Instruments. This chassis supports up to 12 enterprise class SATA hard drives controlled by a 12-port PCI Express RAID controller. This system has been preconfigured as RAID 0; however, the system supports additional modes such as RAID 1, RAID 5, RAID 6, RAID 10, RAID 50, and JBOD. Refer to the included RAID controller user manual or guide for more information about these modes.

HDD-826x uses PCI Express signals over a cable of up to 7 m. You can operate the HDD-826x family in PCIe x4 mode when paired with the NI-8262 (for PXIe chassis use only).

### HDD-8263 x4 System

This entry-level storage system is preconfigured in RAID0 and contains 1 TB of storage capacity. When connected to the NI 8262 in a PXI Express or CompactPCI Express chassis, the system can sequentially read and write a maximum of 300 Mbytes/s on the outside of the array, and approximately 150 Mbytes/s on the inside.

### HDD-8264 x4 System

The highest performance RAID system consists of an NI-8262 in a PXI Express or CompactPCI Express chassis, connected to the HDD-8264. This system can use the full bandwidth of PCI Express x4 technology and can read and write sequentially at more than 600 Mbytes/s across the entire array. The HDD-8264 is preconfigured in RAID0 and contains 3 TB of storage capacity.

## What You Need to Get Started

To set up and use your HDD-826x for PXI Express, you need the following hardware and software to be used with your PXI Express chassis and controller:

- Host: PXIe controller and chassis
- RAID array: HDD-8263 or HDD-8264
- Host connection: NI 8262
- Cable: PCIe x4
- Software: RAID drivers (on the included CD)



**Note** You cannot use the PXIe-8103 controller with HDD-826x.

## Unpacking

Your HDD-826x system is preassembled and preconfigured for use. You need only to remove the HDD-826x RAID storage chassis from the shipping box and assemble your system. There is no need to open your HDD-826x chassis. The system is preconfigured and sealed.

Your HDD-826x system is sensitive to electrostatic damage (ESD). ESD can damage several components on the system.



**Caution** *Never* touch the exposed pins of connectors. Doing so may damage the device.

To avoid such damage in handling the device, take the following precautions:

- Ground yourself using a grounding strap or by holding a grounded object.
- Touch any antistatic packaging to a metal part of the chassis before removing the device from the package.

# Hardware Installation and Use

---

This section explains how to install and use the HDD-826x for PXI Express.

## Hardware Installation for x4 PXIe Solution

The following are general instructions for installing the HDD-826x for PXI Express system. Consult your computer user manual or technical reference manual for specific instructions and warnings.

### Installing an NI 8262

Complete the following steps to install the NI 8262 in your PXI Express or CompactPCI Express chassis:

1. Power off your PXI Express or CompactPCI Express chassis, but leave it plugged in while installing the NI 8262. The power cord grounds the chassis and protects it from electrical damage while you install the module.
2. Locate an available PXI Express or CompactPCI Express slot in the chassis (x4 or greater). The NI 8262 must *not* be installed in the controller slot (slot 1 in a PXI Express chassis).



**Caution** To protect both yourself and the chassis from electrical hazards, leave the chassis off until you finish installing the NI 8262.

3. Remove or open any doors or covers blocking access to the slot in which you intend to install the NI 8262.
4. Touch the metal part of the case to discharge any static electricity that might be on your clothes or body.
5. Make sure the injector/ejector handle is in its downward position. Be sure to remove all connector packaging and protective caps from retaining screws on the module. Align the NI 8262 with the card guides on the top and bottom of the system controller slot.



**Caution** Do *not* raise the injector/ejector handle as you insert the NI 8262. It will not insert properly unless the handle is in its downward position so that it does not interfere with the injector/ejector rail on the chassis.

6. Hold the handle as you slowly slide the module into the chassis until the handle catches on the injector/ejector rail.
7. Raise the injector/ejector handle until the module firmly seats into the backplane receptacle connectors. The front panel of the NI 8262 should be even with the front panel of the chassis.

8. Tighten the bracket-retaining screws on the top and bottom of the front panel to secure the NI 8262 to the chassis.
9. Replace or close any doors or covers to the chassis.

## Cabling

Connect the cabled PCI Express x4 cable to both NI 8262 and the HDD-826x chassis. The cables have no polarity, so you can connect either end to either the card or chassis.



**Caution** Do *not* remove the cable after the system is powered on. Doing so can hang or cause errors in applications communicating with devices. If a cable becomes unplugged, plug it back into the system. (You may need to restart your computer.)



**Note** For more information about cables, refer to the [Cable Options](#) section.

## Powering Up the HDD-826x for PXI Express System

Follow these steps to power up the HDD-826x for PXI Express system:

1. Turn on the HDD-826x chassis. The power switch is on the power supply on the back of the chassis. The system should not power on when this switch is turned on. Turning this switch to the ON position enables the chassis to be powered on by the host controller when the host is powered on.
2. Power-on the host. The HDD-826x chassis should now turn on.

## Driver Installation

For driver installation information, consult the driver installation chapter of the included RAID controller user manual or guide.

## Powering Down the HDD-826x for PXI Express System

Because operating systems and drivers commonly make the assumption that PCI devices are present in the system from power-up to power-down, it is important not to power off the HDD-826x chassis independently. Powering off the HDD-826x chassis while the host is still on can cause data loss, crashes, or hangs. When you shut down the host controller, the HDD-826x is sent a signal over the cabled PCI Express link to shut down also.

# Reconfiguring the RAID Arrays of the HDD-826x for PXI Express Systems

The HDD-826x systems are preconfigured in RAID0 for performance reasons. Consult the HDD-8264 datasheet for information about additional validated RAID modes. There are two methods of reconfiguring the RAID arrays.



**Caution** Reconfiguring your RAID arrays erases all data on your system. Back up all data before reconfiguring.

- Shortly after powering on your host system, follow the onscreen directions for entering the option ROM configuration menu.
- Install the RAID management software from within Windows XP. The RAID management utility is available on the included CD or from the RAID controller manufacturer's Web site.

Consult the RAID controller user manual or guide for more information about reconfiguring the HDD-826x systems.



**Note** When reconfiguring the HDD-8264, do not create any single array larger than 2 TB. Windows XP and Vista (32-bit operating systems) recognize partitions of only 2 TB or less using this sector size.

Booting from the HDD-826x has not been validated and is not supported. In certain scenarios, due to limited system memory available to load device option ROMs, the RAID controller ROM may not load at boot time. This makes it impossible to boot from the RAID array. However, the array will function properly from within Windows even if the option ROM does not load.

## Hardware Overview

---

This section presents an overview of HDD-826x hardware functionality and explains the operation of each functional unit.

## Functional Overview

The HDD-826x is based on PCI Express technology, as shown in Figure 1. The NI 8262 paired with the HDD-826x uses PCI Express redrivers to enable control of a PCI Express RAID card in an external chassis. The PCI Express redriver architecture is transparent to device drivers, so only the RAID driver is needed for the HDD-826x to function.

The link between the PC and the chassis is a x4 PCI Express link. This link is a dual-simplex communication channel comprised of low-voltage, differentially driven signal pairs. The link can transmit at a rate of 10 Gbps in each direction simultaneously in x4 mode.

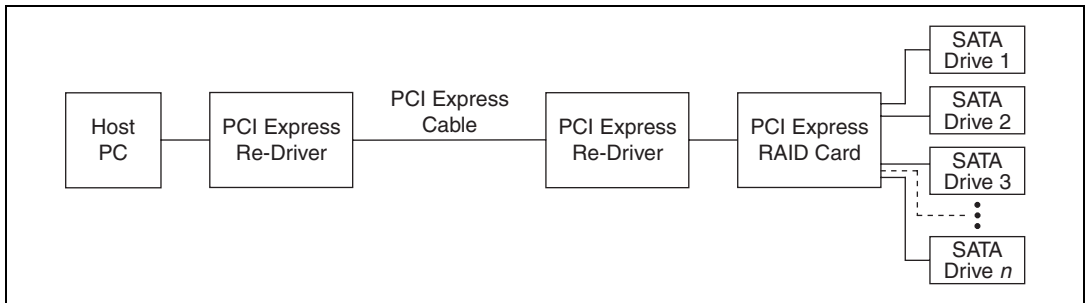

**Figure 1.** Block Diagram of an HDD-826x System

## LED Indicators

The LEDs on HDD-826x cards give status information about power supplies and link state. The back of the HDD-826x has two LEDs, one for power supply status and one for link state.

Table 1 describes the meaning of the LEDs on the back of the HDD-826x.

**Table 1.** NI HDD-826x Back Panel Status LED Messages

LED	Color	Meaning
LINK	Off	Link not established
	Green	Link established
PWR	Off	Power off
	Green	Power on

Each hard drive on the front of the HDD-826x has two LED indicators. Table 2 describes meaning of the LEDs on the front of the hard drives.

**Table 2.** NI HDD-826x Hard Drive Status LED Messages

LED	Color	Meaning
PWR	Off	Drive not available or powered off
	Blue	Drive powered on
ACTIVITY	Off	No read or write activity
	Blue	Read or write in process

## Cable Options

The HDD-826x x4 systems are available with cables of various lengths. Table 3 shows the cables available from National Instruments.

**Table 3.** National Instruments x4 Cables for Use with NI 8262 and HDD-826x

Cable Length (Meters)	Description
3 m	Cabled PCI Express x4 copper cable (part number 779725-03)
7 m	Cabled PCI Express x4 copper cable (part number 779725-07)

## Specifications

---

This section lists the system specifications for the HDD-8263 and HDD-8264 series. These specifications are typical at 25 °C, unless otherwise stated.

### Physical

#### Dimensions

HDD-8263 .....	1U × 440 × 511 mm (1U × 17.3 × 20.1 in.)
HDD-8264 .....	2U × 440 × 508 mm (2U × 17.3 × 20.0 in.)

Maximum cable length ..... 7 m

#### Weight

HDD-8263 .....	11.4 Kg (25.2 lb) typical
HDD-8264 .....	20.4 Kg (45.0 lb) typical

#### Power requirements

HDD-8263 .....	100–240 V, 6–3 A
HDD-8264 .....	100–240 V, 7–3.5 A

### Environment

Maximum altitude.....2,000 m (800 mbar)  
(at 25 °C ambient temperature)

Pollution Degree .....2

Indoor use only.

## Operating Environment

Ambient temperature range..... 0 to 40 °C

Relative humidity range ..... 10 to 90%, noncondensing

## Storage Environment

Ambient temperature range..... –20 to 70 °C

Relative humidity range ..... 5 to 95%, noncondensing

## Cleaning

Clean the HDD-8263/8264 with a soft nonmetallic brush. Make sure that the device is completely dry and free from contaminants before returning it to service.

## Safety

This product is designed to meet the requirements of the following standards of safety for electrical equipment for measurement, control, and laboratory use:

- IEC 60950-1, EN 60950-1
- UL 60950-1, CSA 60950-1



**Note** For UL and other safety certifications, refer to the product label or visit [ni.com/certification](http://ni.com/certification), search by model number or product line, and click the appropriate link in the Certification column.

## Electromagnetic Compatibility

This product is designed to meet the requirements of the following standards of EMC for electrical equipment for measurement, control, and laboratory use:

- EN 55024, CISPR 24 EMC requirements
- EN 55022, CISPR 22 Emissions; Class A
- CE, C-Tick, ICES, and FCC Part 15 Emissions; Class A



**Note** For EMC compliance, operate this device according to product documentation.

## CE Compliance

This product meets the essential requirements of applicable European Directives, as amended for CE marking, as follows:

- 2006/95/EC; Low-Voltage Directive (safety)
- 2004/108/EC; Electromagnetic Compatibility Directive (EMC)



**Note** Refer to the Declaration of Conformity (DoC) for this product for any additional regulatory compliance information. To obtain the DoC for this product, visit [ni.com/certification](http://ni.com/certification), search by model number or product line, and click the appropriate link in the Certification column.

## Environmental Management

National Instruments is committed to designing and manufacturing products in an environmentally responsible manner. NI recognizes that eliminating certain hazardous substances from our products is beneficial not only to the environment but also to NI customers.

For additional environmental information, refer to the *NI and the Environment* Web page at [ni.com/environment](http://ni.com/environment). This page contains the environmental regulations and directives with which NI complies, as well as other environmental information not included in this document.

## Waste Electrical and Electronic Equipment (WEEE)



**EU Customers** At the end of their life cycle, all products *must* be sent to a WEEE recycling center. For more information about WEEE recycling centers and National Instruments WEEE initiatives, visit [ni.com/environment/weee.htm](http://ni.com/environment/weee.htm).

## 电子信息产品污染控制管理办法（中国 RoHS）



**中国客户** National Instruments 符合中国电子信息产品中限制使用某些有害物质指令 (RoHS)。关于 National Instruments 中国 RoHS 合规性信息，请登录 [ni.com/environment/rohs\\_china](http://ni.com/environment/rohs_china)。(For information about China RoHS compliance, go to [ni.com/environment/rohs\\_china](http://ni.com/environment/rohs_china).)

# Compliance with FCC/Canada Radio Frequency Interference Regulations

---

## Determining FCC Class

The Federal Communications Commission (FCC) has rules to protect wireless communications from interference. The FCC places digital electronics into two classes. These classes are known as Class A (for use in industrial-commercial locations only) or Class B (for use in residential or commercial locations). All National Instruments (NI) products are FCC Class A products.

Depending on where it is operated, this Class A product could be subject to restrictions in the FCC rules. (In Canada, the Department of Communications (DOC), of Industry Canada, regulates wireless interference in much the same way.) Digital electronics emit weak signals during normal operation that can affect radio, television, or other wireless products.

All Class A products display a simple warning statement of one paragraph in length regarding interference and undesired operation. The FCC rules have restrictions regarding the locations where FCC Class A products can be operated.

Consult the FCC Web site at [www.fcc.gov](http://www.fcc.gov) for more information.

## FCC/DOC Warnings

This equipment generates and uses radio frequency energy and, if not installed and used in strict accordance with the instructions in this manual and the CE marking Declaration of Conformity<sup>1</sup>, may cause interference to radio and television reception. Classification requirements are the same for the Federal Communications Commission (FCC) and the Canadian Department of Communications (DOC).

Changes or modifications not expressly approved by NI could void the user's authority to operate the equipment under the FCC Rules.

---

<sup>1</sup> The CE marking Declaration of Conformity contains important supplementary information and instructions for the user or installer.

## Class A

### **Federal Communications Commission**

This equipment has been tested and found to comply with the limits for a Class A digital device, pursuant to part 15 of the FCC Rules. These limits are designed to provide reasonable protection against harmful interference when the equipment is operated in a commercial environment. This equipment generates, uses, and can radiate radio frequency energy and, if not installed and used in accordance with the instruction manual, may cause harmful interference to radio communications. Operation of this equipment in a residential area is likely to cause harmful interference in which case the user is required to correct the interference at their own expense.

### **Canadian Department of Communications**

This Class A digital apparatus meets all requirements of the Canadian Interference-Causing Equipment Regulations.

Cet appareil numérique de la classe A respecte toutes les exigences du Règlement sur le matériel brouilleur du Canada.

### **Compliance with EU Directives**

Users in the European Union (EU) should refer to the Declaration of Conformity (DoC) for information<sup>1</sup> pertaining to the CE marking. Refer to the Declaration of Conformity (DoC) for this product for any additional regulatory compliance information. To obtain the DoC for this product, visit [ni.com/certification](http://ni.com/certification), search by model number or product line, and click the appropriate link in the Certification column.

---

<sup>1</sup> The CE marking Declaration of Conformity contains important supplementary information and instructions for the user or installer.

# Where to Go for Support

---

The National Instruments Web site is your complete resource for technical support. At [ni.com/support](http://ni.com/support) you have access to everything from troubleshooting and application development self-help resources to email and phone assistance from NI Application Engineers.

National Instruments corporate headquarters is located at 11500 North Mopac Expressway, Austin, Texas, 78759-3504. National Instruments also has offices located around the world to help address your support needs. For telephone support in the United States, create your service request at [ni.com/support](http://ni.com/support) and follow the calling instructions or dial 512 795 8248. For telephone support outside the United States, contact your local branch office:

Australia 1800 300 800, Austria 43 662 457990-0,  
Belgium 32 (0) 2 757 0020, Brazil 55 11 3262 3599,  
Canada 800 433 3488, China 86 21 5050 9800,  
Czech Republic 420 224 235 774, Denmark 45 45 76 26 00,  
Finland 358 (0) 9 725 72511, France 01 57 66 24 24,  
Germany 49 89 7413130, India 91 80 4190000, Israel 972 3 6393737,  
Italy 39 02 41309277, Japan 0120-527196, Korea 82 02 3451 3400,  
Lebanon 961 (0) 1 33 28 28, Malaysia 1800 887710,  
Mexico 01 800 010 0793, Netherlands 31 (0) 348 433 466,  
New Zealand 0800 553 322, Norway 47 (0) 66 90 76 60,  
Poland 48 22 3390150, Portugal 351 210 311 210, Russia 7 495 783 6851,  
Singapore 1800 226 5886, Slovenia 386 3 425 42 00,  
South Africa 27 0 11 805 8197, Spain 34 91 640 0085,  
Sweden 46 (0) 8 587 895 00, Switzerland 41 56 2005151,  
Taiwan 886 02 2377 2222, Thailand 662 278 6777,  
Turkey 90 212 279 3031, United Kingdom 44 (0) 1635 523545

# Important Information

---

## Warranty

The HDD-8263/8264 is warranted against defects in materials and workmanship for a period of one year from the date of shipment, as evidenced by receipts or other documentation. National Instruments will, at its option, repair or replace equipment that proves to be defective during the warranty period. This warranty includes parts and labor.

The media on which you receive National Instruments software are warranted not to fail to execute programming instructions, due to defects in materials and workmanship, for a period of 90 days from date of shipment, as evidenced by receipts or other documentation. National Instruments will, at its option, repair or replace software media that do not execute programming instructions if National Instruments receives notice of such defects during the warranty period. National Instruments does not warrant that the operation of the software shall be uninterrupted or error free.

A Return Material Authorization (RMA) number must be obtained from the factory and clearly marked on the outside of the package before any equipment will be accepted for warranty work. National Instruments will pay the shipping costs of returning to the owner parts which are covered by warranty.

National Instruments believes that the information in this document is accurate. The document has been carefully reviewed for technical accuracy. In the event that technical or typographical errors exist, National Instruments reserves the right to make changes to subsequent editions of this document without prior notice to holders of this edition. The reader should consult National Instruments if errors are suspected. In no event shall National Instruments be liable for any damages arising out of or related to this document or the information contained in it.

EXCEPT AS SPECIFIED HEREIN, NATIONAL INSTRUMENTS MAKES NO WARRANTIES, EXPRESS OR IMPLIED, AND SPECIFICALLY DISCLAIMS ANY WARRANTY OF MERCHANTABILITY OR FITNESS FOR A PARTICULAR PURPOSE. CUSTOMER'S RIGHT TO RECOVER DAMAGES CAUSED BY FAULT OR NEGLIGENCE ON THE PART OF NATIONAL INSTRUMENTS SHALL BE LIMITED TO THE AMOUNT THEREOF PAID BY THE CUSTOMER. NATIONAL INSTRUMENTS WILL NOT BE LIABLE FOR DAMAGES RESULTING FROM LOSS OF DATA, PROFITS, USE OF PRODUCTS, OR INCIDENTAL OR CONSEQUENTIAL DAMAGES, EVEN IF ADVISED OF THE POSSIBILITY THEREOF. This limitation of the liability of National Instruments will apply regardless of the form of action, whether in contract or tort, including negligence. Any action against National Instruments must be brought within one year after the cause of action accrues. National Instruments shall not be liable for any delay in performance due to causes beyond its reasonable control. The warranty provided herein does not cover damages, defects, malfunctions, or service failures caused by owner's failure to follow the National Instruments installation, operation, or maintenance instructions; owner's modification of the product; owner's abuse, misuse, or negligent acts; and power failure or surges, fire, flood, accident, actions of third parties, or other events outside reasonable control.

## Copyright

Under the copyright laws, this publication may not be reproduced or transmitted in any form, electronic or mechanical, including photocopying, recording, storing in an information retrieval system, or translating, in whole or in part, without the prior written consent of National Instruments Corporation.

National Instruments respects the intellectual property of others, and we ask our users to do the same. NI software is protected by copyright and other intellectual property laws. Where NI software may be used to reproduce software or other materials belonging to others, you may use NI software only to reproduce materials that you may reproduce in accordance with the terms of any applicable license or other legal restriction.

## Trademarks

National Instruments, NI, ni.com, and LabVIEW are trademarks of National Instruments Corporation. Refer to the *Terms of Use* section on [ni.com/legal](http://ni.com/legal) for more information about National Instruments trademarks.

Other product and company names mentioned herein are trademarks or trade names of their respective companies.

## Patents

For patents covering National Instruments products, refer to the appropriate location: **Help>Patents** in your software, the `patents.txt` file on your CD, or [ni.com/patents](http://ni.com/patents).

## WARNING REGARDING USE OF NATIONAL INSTRUMENTS PRODUCTS

(1) NATIONAL INSTRUMENTS PRODUCTS ARE NOT DESIGNED WITH COMPONENTS AND TESTING FOR A LEVEL OF RELIABILITY SUITABLE FOR USE IN OR IN CONNECTION WITH SURGICAL IMPLANTS OR AS CRITICAL COMPONENTS IN ANY LIFE SUPPORT SYSTEMS WHOSE FAILURE TO PERFORM CAN REASONABLY BE EXPECTED TO CAUSE SIGNIFICANT INJURY TO A HUMAN.

(2) IN ANY APPLICATION, INCLUDING THE ABOVE, RELIABILITY OF OPERATION OF THE SOFTWARE PRODUCTS CAN BE IMPAIRED BY ADVERSE FACTORS, INCLUDING BUT NOT LIMITED TO FLUCTUATIONS IN ELECTRICAL POWER SUPPLY, COMPUTER HARDWARE MALFUNCTIONS, COMPUTER OPERATING SYSTEM SOFTWARE FITNESS, FITNESS OF COMPILERS AND DEVELOPMENT SOFTWARE USED TO DEVELOP AN APPLICATION, INSTALLATION ERRORS, SOFTWARE AND HARDWARE COMPATIBILITY PROBLEMS, MALFUNCTIONS OR FAILURES OF ELECTRONIC MONITORING OR CONTROL DEVICES, TRANSIENT FAILURES OF ELECTRONIC SYSTEMS (HARDWARE AND/OR SOFTWARE), UNANTICIPATED USES OR MISUSES, OR ERRORS ON THE PART OF THE USER OR APPLICATIONS DESIGNER (ADVERSE FACTORS SUCH AS THESE ARE HEREAFTER COLLECTIVELY TERMED "SYSTEM FAILURES"). ANY APPLICATION WHERE A SYSTEM FAILURE WOULD CREATE A RISK OF HARM TO PROPERTY OR PERSONS (INCLUDING THE RISK OF BODILY INJURY AND DEATH) SHOULD NOT BE RELIANT SOLELY UPON ONE FORM OF ELECTRONIC SYSTEM DUE TO THE RISK OF SYSTEM FAILURE. TO AVOID DAMAGE, INJURY, OR DEATH, THE USER OR APPLICATION DESIGNER MUST TAKE REASONABLY PRUDENT STEPS TO PROTECT AGAINST SYSTEM FAILURES, INCLUDING BUT NOT LIMITED TO BACK-UP OR SHUT-DOWN MECHANISMS. BECAUSE EACH END-USER SYSTEM IS CUSTOMIZED AND DIFFERS FROM NATIONAL INSTRUMENTS' TESTING PLATFORMS AND BECAUSE A USER OR APPLICATION DESIGNER MAY USE NATIONAL INSTRUMENTS PRODUCTS IN COMBINATION WITH OTHER PRODUCTS IN A MANNER NOT EVALUATED OR CONTEMPLATED BY NATIONAL INSTRUMENTS, THE USER OR APPLICATION DESIGNER IS ULTIMATELY RESPONSIBLE FOR VERIFYING AND VALIDATING THE SUITABILITY OF NATIONAL INSTRUMENTS PRODUCTS WHENEVER NATIONAL INSTRUMENTS PRODUCTS ARE INCORPORATED IN A SYSTEM OR APPLICATION, INCLUDING, WITHOUT LIMITATION, THE APPROPRIATE DESIGN, PROCESS AND SAFETY LEVEL OF SUCH SYSTEM OR APPLICATION.

National Instruments, NI, ni.com, and LabVIEW are trademarks of National Instruments Corporation. Refer to the *Terms of Use* section on [ni.com/legal](http://ni.com/legal) for more information about National Instruments trademarks. Other product and company names mentioned herein are trademarks or trade names of their respective companies. For patents covering National Instruments products, refer to the appropriate location: **Help>Patents** in your software, the `patents.txt` file on your CD, or [ni.com/patents](http://ni.com/patents).

