

Kodak Megaplug ES 1.0 Kodak Megaplug ES 1.0/SC Kodak Megaplug ES 1.0/10 BIT Kodak Megaplug ES 1.0/TH

Camera Information

- Scan Type: Area
- Color: Monochrome
- Image Size: 1008 (H) x 1018 (V)
- Pixel Depth: 8 bits (ES 1.0, ES 1.0/SC, ES 1.0/TH)
10 bits (ES 1.0/10 BIT)
- Frame Rate: 15 FPS (ES 1.0/SC)
30 FPS (ES 1.0, ES 1.0/10 BIT)
- Clock Rate: 20 MHz
- Num. Taps: 1 (ES 1.0/SC)
2 (ES 1.0, ES 1.0/10 BIT)
- Camera Control: RS-232
- Signal Levels: RS-422 (Data, Clock, and Camera Enables)

National Instruments IMAQ Devices

- IMAQ PCI-1424

National Instruments Camera Files

- Kodak ES 1.0.icd Kodak ES 1.0, Kodak ES 1.0/TH
- Kodak ES 1.0 SC.icd Kodak ES 1.0/SC
- Kodak ES 1.0 10bit.icd Kodak ES 1.0/10 BIT

National Instruments Cables

- Kodak Camera Cable 185275-02

Camera Attributes

The following is a list of attributes available for the Kodak ES 1.0 series of cameras. You can modify the values of these attributes either through the IMAQ Configuration Utility or directly in your application code.

Camera Mode

There are four modes of operation for the Kodak ES 1.0 cameras. These modes control how the camera acquires images.

Continuous

The **Continuous** mode of operation is a free-running mode; the camera will take images at a fixed rate of either 30 fps (ES 1.0, ES1.0/10 BIT) or 15 fps (ES 1.0/SC).

Controlled

In the **Controlled** mode of camera operation, the time at which the camera begins acquiring the image and the exposure time of the image are controlled directly by the user. The start of an acquisition occurs at the assertion edge of a trigger input to the camera and continues for the length of time that the trigger input is held asserted, giving the user direct control of the exposure time of the CCD. The camera takes this trigger input either directly from the external Trigger input on the rear panel of the camera or from the National Instruments IMAQ device as configured by the **Trigger Source** camera attribute described below. In the **Controlled** mode of operation the frame rate is not fixed, but rather is inversely proportional to the exposure time plus the camera readout time. The exposure time is theoretically unlimited, but at room temperatures dark field non-uniformities become noticeable when the exposure time is greater than 100 ms.

Trigger Source

The **Trigger Source** attribute specifies to the camera the location of the trigger line to use as an asynchronous reset to the camera and to start the frame readout. By choosing the **Camera Connector** option, you must supply a TTL level pulse, the duration of which determines the frame exposure time.

Camera Connector

Choose this option to configure the camera to use the Trigger connector on the rear panel of the camera to control the camera's exposure time and start the frame readout. This is the default value of this parameter.

Trigger Polarity

This parameter determines the polarity of the pulse that you will supply to the rear panel of the camera to initiate the frame readout.

High-True

Choosing this option, the camera's CCD sensor will be exposed for the period of time in which the trigger input is high (TTL 5V).

Low-True

Choosing this option, the camera's CCD sensor will be exposed for the period of time in which the trigger input is low (TTL 0V).

Frame Grabber

Choose this option to configure the camera to use a signal from the National Instruments IMAQ device as an asynchronous reset to the camera.

Exposure Pulse Width

When you choose the **Trigger Source** attribute to be **Frame Grabber**, the software automatically configures the camera and provides a pulse to the camera. The **Exposure Pulse Width** attribute configures the width of this pulse, and thus the camera's exposure time. This parameter is specified in milliseconds from 0.05 ms to 100.00 ms in steps of 0.0005 ms.

Triggered

In the **Triggered** mode, each exposure is started by a signal connected to either the Trigger input on the rear panel of the camera or from the National Instruments IMAQ device as configured by the **Trigger Source** camera attribute described below. The **Exposure Time** camera attribute sets the exposure time. National Instruments recommends keeping the **Trigger Source** attribute in its default, **Camera Connector**, setting in order to achieve the most precise timing. In this mode, the exposure starts 20 μ s (\pm 100 ns) after the assertion edge of the trigger pulse and ends at the exposure time selected by the **Exposure Time** camera attribute.

Trigger Source

The **Trigger Source** attribute specifies to the camera the location of the trigger line to use as an asynchronous reset to the camera and to start the frame readout. By choosing the **Camera Connector** option, you must supply a TTL level pulse to start the camera's acquisition.

Camera Connector

Choose this option to configure the camera to use the Trigger connector on the rear panel of the connector for triggering the camera. This is the default value of this parameter.

Trigger Polarity

This parameter determines the polarity of the pulse that you will supply to the rear panel of the camera to initiate the frame readout.

High-True

Choosing this option, the camera's CCD sensor will begin acquiring data upon the *rising* edge of the trigger signal on the rear panel of the camera.

Low-True

Choosing this option, the camera's CCD sensor will begin acquiring data upon the *falling* edge of the trigger signal on the rear panel of the camera.

Frame Grabber

Choose this option to configure the camera to use a signal from the National Instruments IMAQ device as an asynchronous reset to the camera.

Triggered Double Exposure

The **Triggered Double Exposure** mode is a specialty mode of the Kodak ES 1.0 camera that allows the camera to take two images in rapid succession from the assertion edge of a trigger provided to the external trigger input on the rear panel of the camera. *You must provide a TTL-level trigger to the camera in this mode.* Use this mode with a strobe light for illuminating the two frames. The first of these two images has an exposure time set by the **Transfer Pulse Delay** parameter described below, while the second image always has an exposure time of 33 ms. However, since both images are illuminated with a strobe light, their overall image intensities should be very similar. See the timing diagram in Figure 1 for additional information.

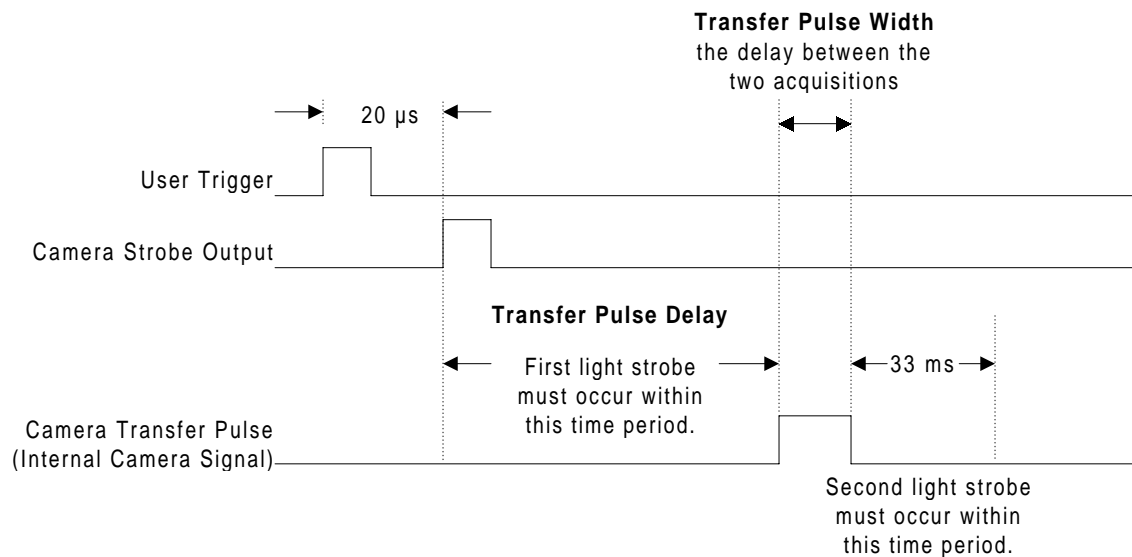

Figure 1. Triggered Double Exposure Mode Timing

Trigger Polarity

This parameter determines the polarity of the pulse that you will supply to the rear panel of the camera to initiate the frame readout.

High-True

Choosing this option, the camera's CCD sensor will begin acquiring data upon the *rising* edge of the trigger signal on the rear panel of the camera.

Low-True

Choosing this option, the camera's CCD sensor will begin acquiring data upon the *falling* edge of the trigger signal on the rear panel of the camera.

Transfer Pulse Delay

This camera attribute is valid only when the Kodak camera is in the **Triggered Double Exposure** mode. It configures the delay from the assertion edge of the camera strobe output (located on the rear panel of the camera) to the end of the exposure time for the first image of the **Triggered Double Exposure** mode. The first illumination of the strobe light needs to occur within the **Transfer Pulse Delay** time. This attribute can be set from 1 μ s to 255 μ s in increments of 1 μ s.

To determine the correct setting of the **Transfer Pulse Delay**, determine the light output delay of your strobe light. Program the value if this delay to be at least this light output delay plus the duration of the light strobe. In most applications, this delay should be as short as your strobe light will allow so that the two captured images will be as close in time as possible.

Transfer Pulse Width

The transfer pulse width of the camera represents the amount of time between the exposures of the two images. The default value for the transfer pulse width is 5 μ s. If you need a shorter time between your two exposures, you will need to change the value of the **Transfer Pulse Width** to match your timing needs. This parameter can be varied from 1 μ s to 5 μ s in increments of 1 μ s.

Exposure Time

This camera attribute sets the exposure time of the camera in the **Continuous** and **Triggered** camera modes described above. The **Exposure Time** can be set in increments of 0.0636 ms. For the Kodak ES 1.0/SC, possible values for this attribute range from 0.1272 to 64.872 ms, while for the Kodak ES 1.0 and ES 1.0/10 BIT cameras, the possible values are from 0.1272 to 32.436 ms.

Black Level

The **Black Level** control functions much like the brightness control on a television set. The factory default video black level is set so that the output video is just above the black clipping level with the lens capped. **Black Level** can be varied over a range of $\pm 50\%$ of peak white video.

Black Level Balance

The **Black Level Balance** of the two input video channels must be closely matched to minimize line-to-line shading. The **Black Level Balance** command adjusts the black level of one channel (tap) with respect to the other. With the lens capped, change the **Black Level Balance** until you are satisfied with the balance between the black levels of the odd and even lines. (ES 1.0 and ES 1.0/10 BIT only).

Gain

The **Gain** attribute allows you to control the camera's onboard pixel gain circuitry.

Unity

The camera does not apply any gain to the image.

Times 2

The camera applies a gain of 2 to the pixel intensities.

Times 4

The camera applies a gain of 4 to the pixel intensities.

Gain Balance

The gain of the two output video channels (taps) must be matched to minimize the line to line shading. The **Gain Balance** attribute adjusts the gain of one channel with respect to the other (ES 1.0 and ES 1.0/10 BIT only).

Strobe Polarity

The Strobe output on the rear of the camera provides a pulse output capable of driving a 50 Ω load. The assertion edge of this output, configured by this attribute, can be used to fire a strobe light for scene illumination.

High-True

Choosing this option configures the Strobe output on the rear panel of the camera to be high-true.

Low-True

Choosing this option configures the Strobe output on the rear panel of the camera to be low-true.

Defect Conceal

Sensors are not perfect and have some areas that react differently to light. You can see these imperfect pixels as a column that is different in intensity from its neighbors. The sensor is characterized to locate defective columns. The defective column locations are then programmed into the camera at the factory. When you turn on the **Defect Conceal** attribute, the camera replaces the defective areas with information derived from the nearby pixels making the defects disappear. This image enhancement circuitry is said to maximize the image uniformity.

On

Set the **Defect Conceal** attribute to **On** to enable the camera's defect conceal circuitry.

Off

Set the **Defect Conceal** attribute to **Off** to disable the camera's defect conceal circuitry.

Display Wedge

This camera attribute directs the camera to send, instead of an acquired image, a linearly increasing grayscale pattern that reaches peak white and then resets to black. This feature is useful for configuring the camera attributes and IMAQ board settings.

On

Set the **Display Wedge** attribute to **On** to configure the camera's to replace the video received from the CCD with the wedge pattern.

Off

Set the **Defect Conceal** attribute to **Off** to enable the camera's to send the images capture from the CCD to the IMAQ device.

Examples

LabVIEW

Use the IMAQ_Set_Camera_Attribute VI to set any of the camera attributes listed above in LabVIEW. Both the camera attribute name and the camera attribute value are passed to the VI as a string constant. NI-IMAQ then parses this string and takes the appropriate action to make the change. Figure 2 shows an example that changes both the exposure time and the camera mode.

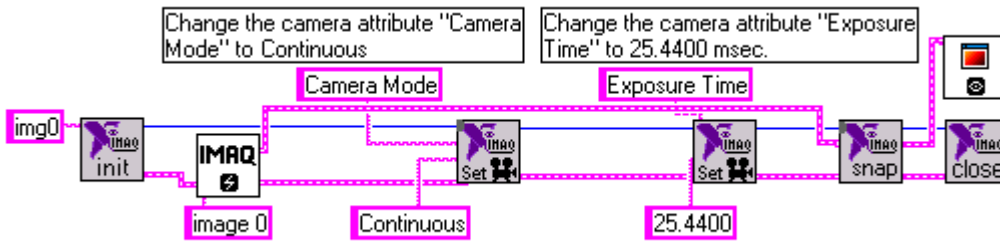

Figure 2. Changing Camera Attributes in LabVIEW

To set any of the camera sub-attributes listed above, simply program them just as you would one of the main camera attributes, as shown in Figure 3. In this example, we set the **Transfer Pulse Delay** parameter of the **Triggered Double Exposure** camera mode to 200 μ s.

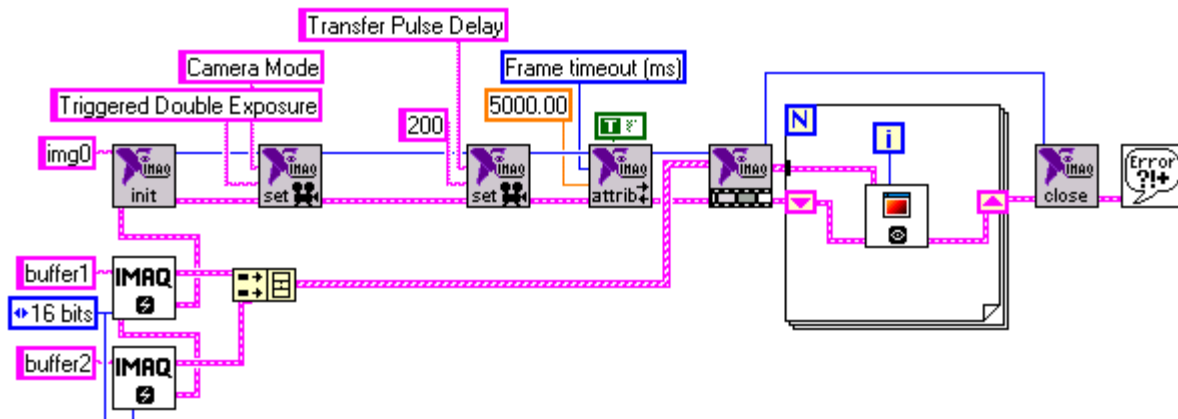

Figure 3. Programming Camera Sub-Attributes in LabVIEW

C/C++

You can also set any of the camera attributes in C/C++. In LabVIEW, only one function sets a camera attribute. In this function, both the camera attribute and the attribute value are passed to the function as string constants. In C there are two functions, one similar to the LabVIEW VI that accepts both parameters as string constants, and another in which the attribute value can be passed directly as a numeric. Below is a sample of code written in C that performs the same operation as the LabVIEW example.

```
INTERFACE_ID    iid;
SESSION_ID     sid;
UInt8          *buffer = NULL;

ImgInterfaceOpen("img0", &iid);
ImgSessionOpen(iid, &sid);

/* The imgSetCameraAttributeString() function can be used to set the value
   of any of the attributes above. */
imgSetCameraAttributeString(sid, "Camera Mode", "Continuous", strlen
    ("Continuous"));

/* The imgSetCameraAttributeNumeric() function can be used to set the
   value of only the camera attributes with numeric values such as
   Exposure Time. */
imgSetCameraAttributeNumeric(sid, "Exposure Time", 18.4440);

/* or */

imgSetCameraAttributeString(sid, "Exposure Time", "18.4440", strlen
    ("18.4440"));

imgSnap(sid, buffer);

/* Your image processing or display functions go here */

imgClose (iid, TRUE);
```

Below is a sample of code written in C that performs a full acquisition from the Kodak ES 1.0 camera in its **Triggered Double Exposure** mode of operation. In addition to capturing the two images from the camera as the LabVIEW VI does, this code starts the acquisition upon receiving a trigger from the user on External trigger 0. It also generates two pulses on External triggers 2 and 3. These pulses could be used to fire the two light strobes required in the **Triggered Double Exposure** mode of operation.

```
#include <stdio.h>
#include "niimaq.h"

#define NUMBER_OF_BUFFERS 2
main()
{
    INTERFACE_ID    iid;
    SESSION_ID     sid;
    PULSE_ID       strobe1, strobe2;           // You will need two pulse Ids -
                                                // one for each strobe light
    char           *buffers[2];              // We need two buffers for
                                                // Triggered Double Exposure
```

```

unsigned int    skippedBuffers[2] = {0,0}; // You must set the skip
                                                counts to 0

double         transfer_pulse_delay = 255;
double         transfer_pulse_width = 5;

uInt32         pulse1_delay; // Specifies the offset from the trigger
                             input to the firing of strobe 1
uInt32         pulse1_width; // Specifies the width of the pulse to
                             strobe light 1
uInt32         pulse2_delay; // Specifies the offset from the trigger
                             input to the firing of strobe 2
uInt32         pulse2_width; // Specifies the width of the pulse to
                             strobe light 2

ImgInterfaceOpen("img0", &iid); // Open an interface to the IMAQ device
ImgSessionOpen(iid, &sid);     // Open a session to the IMAQ device

/* The imgSetCameraAttributeString() function can be used to set the value
   of any of the attributes above. */
imgSetCameraAttributeString(sid, "Camera Mode", "Triggered Double
    Exposure", strlen ("Triggered Double Exposure"));
imgSetCameraAttributeNumeric(sid, "Transfer Pulse Delay",
    transfer_pulse_delay);
imgSetCameraAttributeNumeric(sid, "Transfer Pulse Width",
    transfer_pulse_width);

//
// Configure Pulse to Strobe light 1
//
// Since the timebase for the pulse is 50 MHz (20 ns period), the pulse
// delay and width must
// be calculated in terms of ns (20 ns periods to be exact).
//
// pulse1_delay = [20 us delay of camera(see timing diagram) + 20 us
// delay(arbitrarily chosen)] / 20 ns clock period
// pulse1_width = [strobe time(arbitrarily chosen to be 50 us)] / 20 ns
// clock period
pulse1_delay = (20000 + 20000)/20;
pulse1_width = (50000)/20;

//
// This pulse create function will define a pulse_id which can later be
// used with imgPulseStart()
// The pulse is set to begin on the rising edge of External Trigger 0.
imgPulseCreate(PULSE_TIMEBASE_50MHZ, pulse1_delay, pulse1_width,
    IMG_EXT_TRIG0, IMG_PULSE_POLAR_ACTIVEH, IMG_EXT_TRIG2,
    IMG_PULSE_POLAR_ACTIVEH, PULSE_MODE_SINGLE, &strobe1);

```

```

//
// Configure Pulse to Strobe light 1
//
// pulse2_delay = [20us delay of camera(see timing diagram) +
//                 transfer pulse delay (converted to ns) +
//                 transfer pulse delay (converted to ns) +
//                 (20us delay(arbitrarily chosen))] / 20 ns clock period
//
// pulse2_width = [strobe time(arbitrarily chosen to be 50 us)] / 20 ns
// clock period
pulse2_delay = (20000 + transfer_pulse_delay*1000 +
               transfer_pulse_width*1000 + 20000)/20;
pulse2_width = (50000)/20;
imgPulseCreate(PULSE_TIMEBASE_50MHZ, pulse2_delay, pulse2_width,
              IMG_EXT_TRIG0, IMG_PULSE_POLAR_ACTIVEH, IMG_EXT_TRIG3,
              IMG_PULSE_POLAR_ACTIVEH, PULSE_MODE_SINGLE, &strobe2);

//
// The imgPulseStart function actually configures the hardware to be ready
// to generate the pulse.
//
imgPulseStart(strobe1, sid);
imgPulseStart(strobe2, sid);

//
// We also want to trigger the IMAQ PCI-1424 to start on the rising edge
// of the user trigger. Here imgSessionTriggerConfigure() configures the
// hardware to start the sequence based on the rising edge of External
// Trigger 0.
//
imgSessionTriggerConfigure(sid, IMG_EXT_TRIG0, IMG_PULSE_POLAR_ACTIVEH,
                          5000, IMG_TRIG_ACTION_BUFLIST)

// Set the buffer pointers to NULL to have the driver allocate memory
// automatically
buffers[0] = NULL;
buffers[1] = NULL;
imgSequenceSetup (sid, 2, (void **)buffers, skippedBuffers, TRUE, FALSE);

/* Your image processing or display functions go here */

imgClose (iid, TRUE);
}

```