

INSTALLATION GUIDE

8-Slot PXI Backplane

This guide describes installation requirements for the 8-slot PXI backplane, shown in Figure 1.

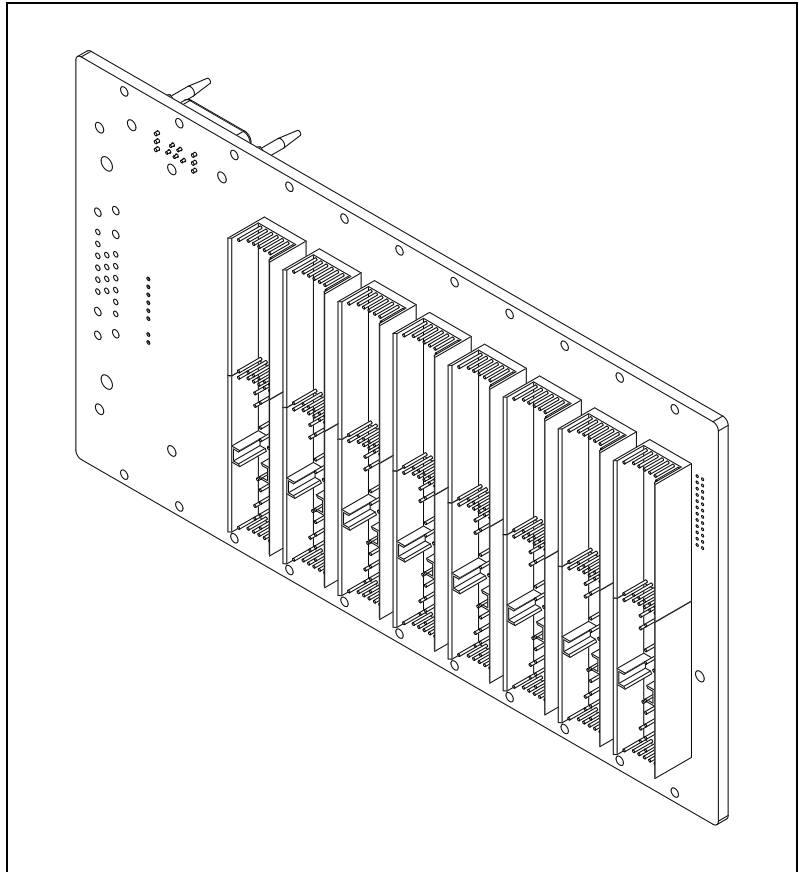

Figure 1. 8-Slot PXI Backplane

Description

The 8-slot PXI backplane contains one PXI controller slot and 7 PXI peripheral slots. It does not include a power supply or cooling solution. You must implement these features when installing the backplane into your system.

Mechanical Requirements

Mounting

Figure 2 shows the backplane dimensions. There are 22 holes available for mounting with M2.5 hardware.

The use of all mounting holes is recommended for proper backplane support.

There are two mounting holes on top of the 8-slot PXI backplane that have plated annular pads on the front and back of the backplane. These mounting holes may be used to connect the backplane ground to the chassis in which the backplane is mounted. If you do not desire to connect backplane ground to the chassis, use insulated washers at these mounting holes. Refer to Figure 4 for the position of the mounting holes.

Cooling



Note National Instruments is not responsible for damage to the backplane if inadequate cooling is used.

You should mount a fan below the backplane. Airflow should be from the bottom to the top of the PXI modules. You must determine the airflow requirements for your system based on the *PXI Hardware Specification*.

Handling



Cautions Be careful to avoid bending or otherwise damaging the pins on the backplane connectors. Bent pins may cause functional failures or damage when the backplane is powered.

To protect both yourself and the backplane from electrical hazards, leave the chassis powered off until you finish installing the PXI controller and modules.



Caution Electrostatic discharge can damage your equipment. To avoid such damage, discharge the static built up on your body by touching a grounded metal object before handling the PXI equipment. Then touch the antistatic plastic package containing the backplane to a metal part of your PXI chassis before removing the backplane from the packaging.

Dimensions

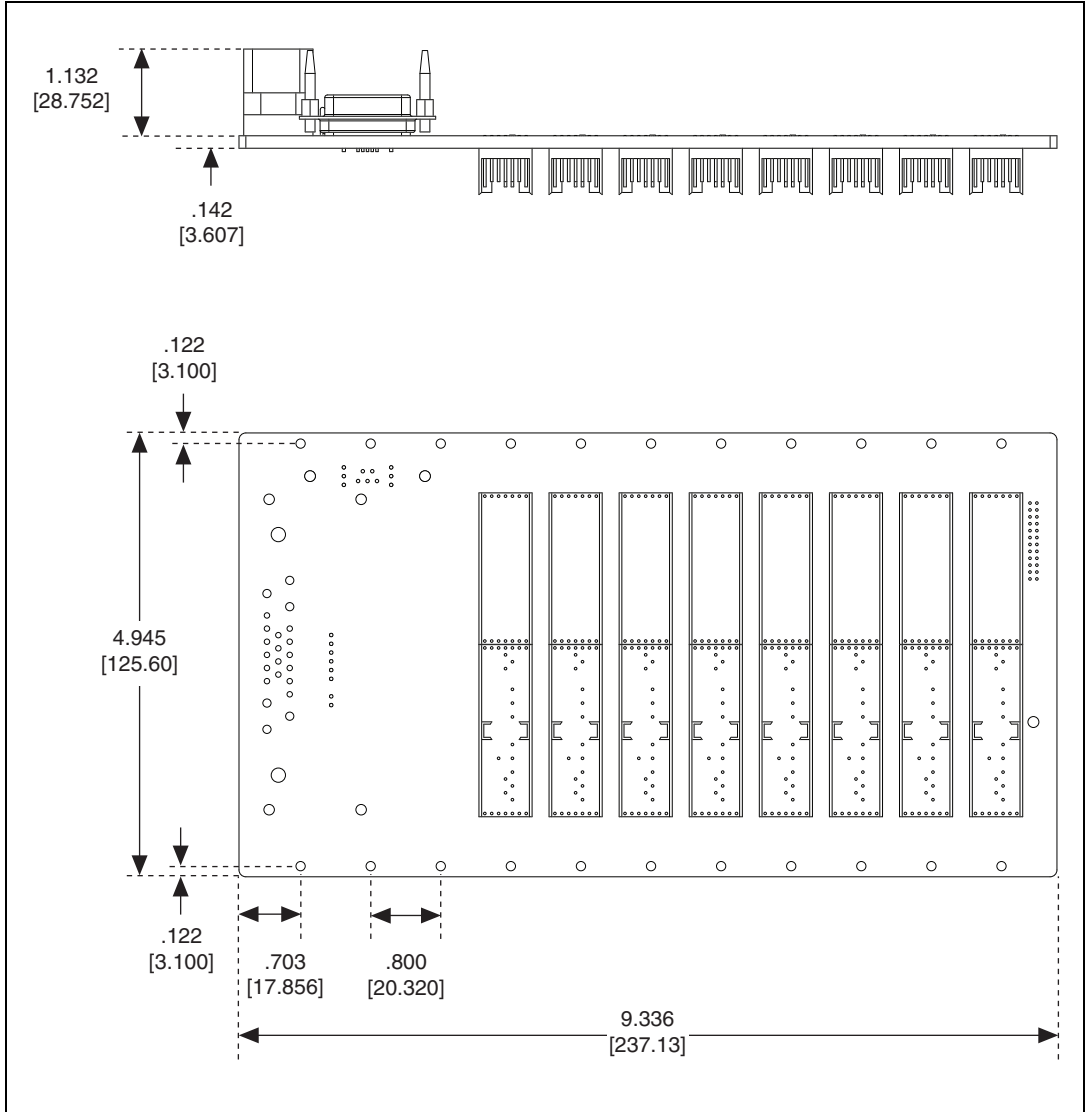

Figure 2. Dimensions

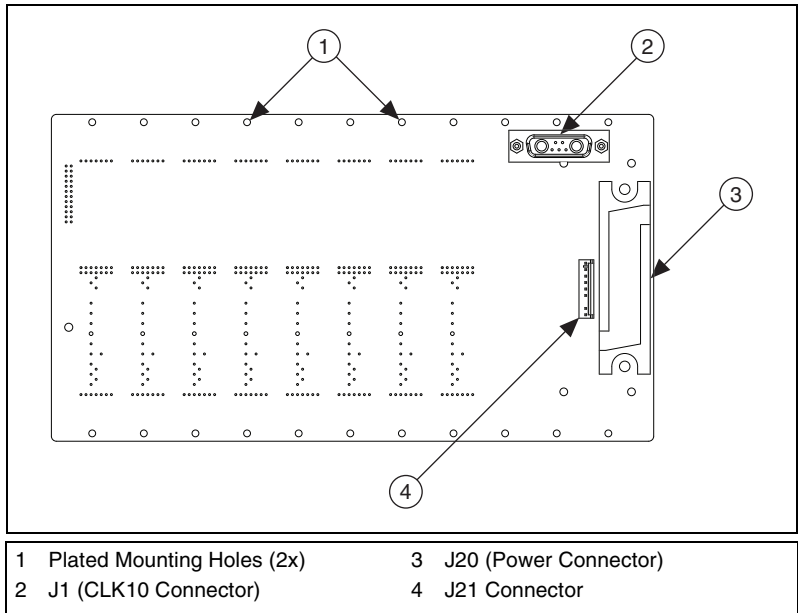

Figure 4. Backplane Power and CLK10 Connectors

Power

Please refer to the *PXI Hardware Specification* for power requirements and to the specifications of the chosen power supply to determine the minimum load required.

Connector J20

Connector J20 is the power supply connector for the 8-slot backplane. The location of the J20 connector is shown in Figure 4. Refer to Table 1 for the pin descriptions. The mating connector for J20 is manufactured by Tyco Electronics, and can be ordered with the part number 1648115-1.



Note The system slot (slot 1) receives +12 V power from pin 17 of J20. If this pin is not connected to +12 V the system controller will not function properly.

Table 1. Connector J20 Pin Descriptions

Connector	Pin	Signal	Description	Required for Basic Power-up
	1	+3.3 V	Backplane +3.3 V power plane.	Yes
	2	GND	Backplane ground plane.	Yes
	3	+3.3 V	Backplane +3.3 V power plane.	Yes
	4	LED2	Connects to pin 8 of J21.	No
	5	INHIBIT	Connects to pin 7 of J21.	No
	6	LED1	Connects to pin 5 of J21.	No
	7	SMB_SDA	Connects to pin C19 on J2 (slot 1).	No
	8	SMB_ALERT#	Connects to pin E19 on J2 (slot 1).	No
	9	SMB_SCL	Connects to pin D19 on J2 (slot 1).	No
	10	THERM1 (optional)	Connects to pin 2 of J21.	No
	11	THERM2 (optional)	Connects to pin 1 of J21.	No
	12	GND	Backplane ground plane.	Yes
	13	GND	Backplane ground plane.	Yes
	14	-12 V	Backplane -12 V power plane.	Yes
	15	I2C_CLK	Connects through R34 to pin A2 of J9.	No
	16	I2C_DAT	Connects through R33 to pin B2 of J9.	No
	17	+12 V_FAN	Separate +12 V for slot 1.	Yes
	18	GND	Backplane ground plane.	Yes
	19	+12 V	Backplane +12 V power plane.	Yes
	20	GND	Backplane ground plane.	Yes
	21	+5 V	Backplane +5 V power plane.	Yes
	22	GND	Backplane ground plane.	Yes

Connector J1

Connector J1 is for interfacing with the backplane's PXI_CLK10 circuitry. The location of the J1 connector is shown in Figure 4. The mating connector for J1 is manufactured by Positronic and can be ordered with the part number CBD7W2M2000Z-759.1.

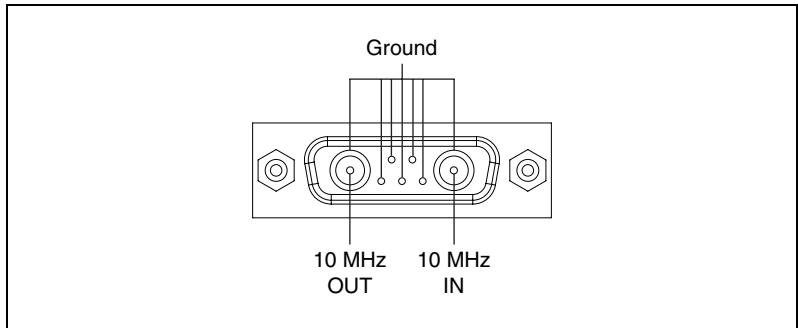

Figure 5. J1 Connector

Connector J21

Connector J21 may be used in conjunction with J20 for interfacing with an inhibit switch, LED, and thermistor. It is not necessary to connect to J21 for basic power-up of the backplane. Refer to Table 2 for the pin descriptions. The mating connector for pins 1–6 of J21 is manufactured by Molex and can be ordered with the part number 22-01-2067.

Table 2. Connector J21 Pin Descriptions

Connector	Pin	Signal	Description
	1	THERM2	Connects to pin 11 of J20
	2	THERM1	Connects to pin 10 of J20
	3	(No Pin)	—
	4	NC	Not connected.
	5	LED1	Connects to pin 6 of J20.
	6	+5V	Connects to backplane's +5V power plane.
	7	INH	Connects to pin 5 of J20.
	8	LED2	Connects to pin 4 of J20.
	9	GND	Connects to backplane's ground plane.

Backplane

Size	3U-sized; one system slot (with three system expansion slots) and seven peripheral slots. Compliant with IEEE 1101.10 mechanical packaging. PXI Specification Revision 2.0 compliant. Accepts both PXI and CompactPCI (PICMG 2.0 R 3.0) 3U modules.
Backplane bare-board material	UL 94 V-0 Recognized
Backplane connectors	Conforms to IEC 917 and IEC 1076-4-101, and are UL 94 V-0 rated
RoHS	8-slot PXI backplane is RoHS-compliant

10 MHz System Reference Clock (PXI_CLK10)

Maximum clock skew
between slots.....250 ps

Built-in 10 MHz clock

Accuracy	± 25 ppm (guaranteed over the operating temperature range)
Maximum jitter	5 ps RMS in 10 Hz to 1 MHz range

External clock sources

Connectors	Connector J1 on rear of backplane (ground referenced) or Slot 2 J2 (pin D17)
Input frequency	10 MHz ± 100 ppm or better
Input amplitude	
Rear connector	200 mV _{pp} to 5 V _{pp} , 10 MHz squarewave or sinewave
Slot 2	5 V or 3.3 V, 10 MHz TTL signal
Input impedance	50 Ω \pm 5 Ω (rear connector)
Maximum jitter introduced by backplane circuitry	1 ps RMS in 10 Hz to 1 MHz range

External clock output

Connector.....	Connector J1 on rear of backplane (ground-referenced)
Output amplitude	1 $V_{pp} \pm 20\%$ squarewave into 50Ω 2 V_{pp} into open circuit
Output impedance	$50 \Omega \pm 5 \Omega$

National Instruments, NI, ni.com, and LabVIEW are trademarks of National Instruments Corporation. Refer to the *Terms of Use* section on ni.com/legal for more information about National Instruments trademarks. Other product and company names mentioned herein are trademarks or trade names of their respective companies. For patents covering National Instruments products, refer to the appropriate location: **Help»Patents** in your software, the `patents.txt` file on your CD, or ni.com/patents.