

TPC-2012

User Manual

Worldwide Technical Support and Product Information

ni.com

National Instruments Corporate Headquarters

11500 North Mopac Expressway Austin, Texas 78759-3504 USA Tel: 512 683 0100

Worldwide Offices

Australia 1800 300 800, Austria 43 0 662 45 79 90 0, Belgium 32 0 2 757 00 20, Brazil 55 11 3262 3599,
Canada 800 433 3488, China 86 21 6555 7838, Czech Republic 420 224 235 774, Denmark 45 45 76 26 00,
Finland 385 0 9 725 725 11, France 33 0 1 48 14 24 24, Germany 49 0 89 741 31 30, India 91 80 41190000,
Israel 972 0 3 6393737, Italy 39 02 413091, Japan 81 3 5472 2970, Korea 82 02 3451 3400,
Lebanon 961 0 1 33 28 28, Malaysia 1800 887710, Mexico 01 800 010 0793, Netherlands 31 0 348 433 466,
New Zealand 0800 553 322, Norway 47 0 66 90 76 60, Poland 48 22 3390150, Portugal 351 210 311 210,
Russia 7 495 783 68 51, Singapore 1800 226 5886, Slovenia 386 3 425 42 00, South Africa 27 0 11 805 8197,
Spain 34 91 640 0085, Sweden 46 0 8 587 895 00, Switzerland 41 56 200 51 51, Taiwan 886 02 2377 2222,
Thailand 662 278 6777, Turkey 90 212 279 3031, United Kingdom 44 0 1635 523545

For further support information, refer to the *Technical Support and Professional Services* appendix. To comment on National Instruments documentation, refer to the National Instruments Web site at ni.com/info and enter the info code `feedback`.

Important Information

Warranty

The TPC-2012 is warranted against defects in materials and workmanship for a period of one year from the date of shipment, as evidenced by receipts or other documentation. National Instruments will, at its option, repair or replace equipment that proves to be defective during the warranty period. This warranty includes parts and labor.

The media on which you receive National Instruments software are warranted not to fail to execute programming instructions, due to defects in materials and workmanship, for a period of 90 days from date of shipment, as evidenced by receipts or other documentation. National Instruments will, at its option, repair or replace software media that do not execute programming instructions if National Instruments receives notice of such defects during the warranty period. National Instruments does not warrant that the operation of the software shall be uninterrupted or error free.

A Return Material Authorization (RMA) number must be obtained from the factory and clearly marked on the outside of the package before any equipment will be accepted for warranty work. National Instruments will pay the shipping costs of returning to the owner parts which are covered by warranty.

National Instruments believes that the information in this document is accurate. The document has been carefully reviewed for technical accuracy. In the event that technical or typographical errors exist, National Instruments reserves the right to make changes to subsequent editions of this document without prior notice to holders of this edition. The reader should consult National Instruments if errors are suspected. In no event shall National Instruments be liable for any damages arising out of or related to this document or the information contained in it.

EXCEPT AS SPECIFIED HEREIN, NATIONAL INSTRUMENTS MAKES NO WARRANTIES, EXPRESS OR IMPLIED, AND SPECIFICALLY DISCLAIMS ANY WARRANTY OF MERCHANTABILITY OR FITNESS FOR A PARTICULAR PURPOSE. CUSTOMER'S RIGHT TO RECOVER DAMAGES CAUSED BY FAULT OR NEGLIGENCE ON THE PART OF NATIONAL INSTRUMENTS SHALL BE LIMITED TO THE AMOUNT THERETOFORE PAID BY THE CUSTOMER. NATIONAL INSTRUMENTS WILL NOT BE LIABLE FOR DAMAGES RESULTING FROM LOSS OF DATA, PROFITS, USE OF PRODUCTS, OR INCIDENTAL OR CONSEQUENTIAL DAMAGES, EVEN IF ADVISED OF THE POSSIBILITY THEREOF. This limitation of the liability of National Instruments will apply regardless of the form of action, whether in contract or tort, including negligence. Any action against National Instruments must be brought within one year after the cause of action accrues. National Instruments shall not be liable for any delay in performance due to causes beyond its reasonable control. The warranty provided herein does not cover damages, defects, malfunctions, or service failures caused by owner's failure to follow the National Instruments installation, operation, or maintenance instructions; owner's modification of the product; owner's abuse, misuse, or negligent acts; and power failure or surges, fire, flood, accident, actions of third parties, or other events outside reasonable control.

Copyright

Under the copyright laws, this publication may not be reproduced or transmitted in any form, electronic or mechanical, including photocopying, recording, storing in an information retrieval system, or translating, in whole or in part, without the prior written consent of National Instruments Corporation.

National Instruments respects the intellectual property of others, and we ask our users to do the same. NI software is protected by copyright and other intellectual property laws. Where NI software may be used to reproduce software or other materials belonging to others, you may use NI software only to reproduce materials that you may reproduce in accordance with the terms of any applicable license or other legal restriction.

Trademarks

National Instruments, NI, ni.com, and LabVIEW are trademarks of National Instruments Corporation. Refer to the *Terms of Use* section on ni.com/legal for more information about National Instruments trademarks.

Other product and company names mentioned herein are trademarks or trade names of their respective companies.

Members of the National Instruments Alliance Partner Program are business entities independent from National Instruments and have no agency, partnership, or joint-venture relationship with National Instruments.

Patents

For patents covering National Instruments products, refer to the appropriate location: **Help»Patents** in your software, the `patents.txt` file on your CD, or ni.com/patents.

WARNING REGARDING USE OF NATIONAL INSTRUMENTS PRODUCTS

(1) NATIONAL INSTRUMENTS PRODUCTS ARE NOT DESIGNED WITH COMPONENTS AND TESTING FOR A LEVEL OF RELIABILITY SUITABLE FOR USE IN OR IN CONNECTION WITH SURGICAL IMPLANTS OR AS CRITICAL COMPONENTS IN ANY LIFE SUPPORT SYSTEMS WHOSE FAILURE TO PERFORM CAN REASONABLY BE EXPECTED TO CAUSE SIGNIFICANT INJURY TO A HUMAN.

(2) IN ANY APPLICATION, INCLUDING THE ABOVE, RELIABILITY OF OPERATION OF THE SOFTWARE PRODUCTS CAN BE IMPAIRED BY ADVERSE FACTORS, INCLUDING BUT NOT LIMITED TO FLUCTUATIONS IN ELECTRICAL POWER SUPPLY, COMPUTER HARDWARE MALFUNCTIONS, COMPUTER OPERATING SYSTEM SOFTWARE FITNESS, FITNESS OF COMPILERS AND DEVELOPMENT SOFTWARE USED TO DEVELOP AN APPLICATION, INSTALLATION ERRORS, SOFTWARE AND HARDWARE COMPATIBILITY PROBLEMS, MALFUNCTIONS OR FAILURES OF ELECTRONIC MONITORING OR CONTROL DEVICES, TRANSIENT FAILURES OF ELECTRONIC SYSTEMS (HARDWARE AND/OR SOFTWARE), UNANTICIPATED USES OR MISUSES, OR ERRORS ON THE PART OF THE USER OR APPLICATIONS DESIGNER (ADVERSE FACTORS SUCH AS THESE ARE HEREAFTER COLLECTIVELY TERMED "SYSTEM FAILURES"). ANY APPLICATION WHERE A SYSTEM FAILURE WOULD CREATE A RISK OF HARM TO PROPERTY OR PERSONS (INCLUDING THE RISK OF BODILY INJURY AND DEATH) SHOULD NOT BE RELIANT SOLELY UPON ONE FORM OF ELECTRONIC SYSTEM DUE TO THE RISK OF SYSTEM FAILURE. TO AVOID DAMAGE, INJURY, OR DEATH, THE USER OR APPLICATION DESIGNER MUST TAKE REASONABLY PRUDENT STEPS TO PROTECT AGAINST SYSTEM FAILURES, INCLUDING BUT NOT LIMITED TO BACK-UP OR SHUT DOWN MECHANISMS. BECAUSE EACH END-USER SYSTEM IS CUSTOMIZED AND DIFFERS FROM NATIONAL INSTRUMENTS' TESTING PLATFORMS AND BECAUSE A USER OR APPLICATION DESIGNER MAY USE NATIONAL INSTRUMENTS PRODUCTS IN COMBINATION WITH OTHER PRODUCTS IN A MANNER NOT EVALUATED OR CONTEMPLATED BY NATIONAL INSTRUMENTS, THE USER OR APPLICATION DESIGNER IS ULTIMATELY RESPONSIBLE FOR VERIFYING AND VALIDATING THE SUITABILITY OF NATIONAL INSTRUMENTS PRODUCTS WHENEVER NATIONAL INSTRUMENTS PRODUCTS ARE INCORPORATED IN A SYSTEM OR APPLICATION, INCLUDING, WITHOUT LIMITATION, THE APPROPRIATE DESIGN, PROCESS AND SAFETY LEVEL OF SUCH SYSTEM OR APPLICATION.

Compliance

Compliance with FCC/Canada Radio Frequency Interference Regulations

Determining FCC Class

The Federal Communications Commission (FCC) has rules to protect wireless communications from interference. The FCC places digital electronics into two classes. These classes are known as Class A (for use in industrial-commercial locations only) or Class B (for use in residential or commercial locations). All National Instruments (NI) products are FCC Class A products.

Depending on where it is operated, this Class A product could be subject to restrictions in the FCC rules. (In Canada, the Department of Communications (DOC), of Industry Canada, regulates wireless interference in much the same way.) Digital electronics emit weak signals during normal operation that can affect radio, television, or other wireless products.

All Class A products display a simple warning statement of one paragraph in length regarding interference and undesired operation. The FCC rules have restrictions regarding the locations where FCC Class A products can be operated.

Consult the FCC Web site at www.fcc.gov for more information.

FCC/DOC Warnings

This equipment generates and uses radio frequency energy and, if not installed and used in strict accordance with the instructions in this manual and the CE marking Declaration of Conformity*, may cause interference to radio and television reception. Classification requirements are the same for the Federal Communications Commission (FCC) and the Canadian Department of Communications (DOC).

Changes or modifications not expressly approved by NI could void the user's authority to operate the equipment under the FCC Rules.

Class A

Federal Communications Commission

This equipment has been tested and found to comply with the limits for a Class A digital device, pursuant to part 15 of the FCC Rules. These limits are designed to provide reasonable protection against harmful interference when the equipment is operated in a commercial environment. This equipment generates, uses, and can radiate radio frequency energy and, if not installed and used in accordance with the instruction manual, may cause harmful interference to radio communications. Operation of this equipment in a residential area is likely to cause harmful interference in which case the user is required to correct the interference at their own expense.

Canadian Department of Communications

This Class A digital apparatus meets all requirements of the Canadian Interference-Causing Equipment Regulations.

Cet appareil numérique de la classe A respecte toutes les exigences du Règlement sur le matériel brouilleur du Canada.

Compliance with EU Directives

Users in the European Union (EU) should refer to the Declaration of Conformity (DoC) for information* pertaining to the CE marking. Refer to the Declaration of Conformity (DoC) for this product for any additional regulatory compliance information. To obtain the DoC for this product, visit ni.com/certification, search by model number or product line, and click the appropriate link in the Certification column.

* The CE marking Declaration of Conformity contains important supplementary information and instructions for the user or installer.

Conventions

The following conventions are used in this manual:

» The » symbol leads you through nested menu items and dialog box options to a final action. The sequence **File»Page Setup»Options** directs you to pull down the **File** menu, select the **Page Setup** item, and select **Options** from the last dialog box.



This icon denotes a note, which alerts you to important information.



This icon denotes a caution, which advises you of precautions to take to avoid injury, data loss, or a system crash. When this symbol is marked on a product, refer to the *Safety* section of Appendix A, *Specifications*, for information about precautions to take.



When symbol is marked on a product, it denotes a warning advising you to take precautions to avoid electrical shock.

bold

Bold text denotes items that you must select or click in the software, such as menu items and dialog box options. Bold text also denotes parameter names.

italic

Italic text denotes variables, emphasis, a cross-reference, or an introduction to a key concept. Italic text also denotes text that is a placeholder for a word or value that you must supply.

monospace

Text in this font denotes text or characters that you should enter from the keyboard, sections of code, programming examples, and syntax examples. This font is also used for the proper names of disk drives, paths, directories, programs, subprograms, subroutines, device names, functions, operations, variables, filenames, and extensions.

Contents

Chapter 1

General Information

Introduction.....	1-1
I/O Ports.....	1-1
Cleaning.....	1-2

Chapter 2

System Setup

Important Safety Information.....	2-1
Setup.....	2-2
Touchscreen Calibration.....	2-3
Panel Mounting.....	2-4

Chapter 3

Jumpers and Connectors

Jumper and Connector Functions.....	3-1
Jumper and Connector Locations.....	3-3

Appendix A

Specifications

Appendix B

Serial Port Settings

Appendix C

Watchdog Timer Programming

Appendix D

Watchdog Timer Programming on WinCE

Appendix E

Accessory Kit Assembly Procedure

Appendix F
Touchscreen Configuration

Appendix G
Fuse Replacement

Appendix H
Technical Support and Professional Services

Index

General Information

This chapter includes general information about the TPC-2012 Human Machine Interface (HMI).

Introduction

The TPC-2012 touch panel computer, a state-of-the-art HMI based on an x86 platform, includes these key features:

- **Fanless**—Because the system uses a low-power processor, it does not need fans, which often are unreliable and cause dust to circulate inside the equipment.
- **Bright display**—The TFT LCD features a 12.1 in. display that meets industrial demands for clear interfaces.
- **Powerful communication capability**—The TPC-2012 is a powerful I/O interface for easy communication with other devices. The I/O interface includes serial ports, a parallel port, and Ethernet and USB 1.1 support. The TPC-2012 also supports the PCI/104 expansion slot, making it easy to expand with PCI/104 modules.
- **Windows CE support**—In addition to Windows XP support, the TPC-2012 supports the Windows CE and Windows XP embedded platforms. An optional Windows CE operating system specifically for the TPC-2012 is available for Windows CE application programmers.

I/O Ports

The TPC-2012 includes the following ports:

- One parallel port that supports EPP/ ECP modes
- Four serial ports: RS232 (COM1, COM2, COM3) and RS232/422/485 (COM4)
- One RJ-45 Ethernet port
- Two PS/2 ports: 6-pin mini-DIN ports for keyboard and mouse
- Two USB 2.0 ports compliant with USB 1.0 and 1.1.
- One PCI/104 slot

Figure 1-1 shows the I/O port arrangement.

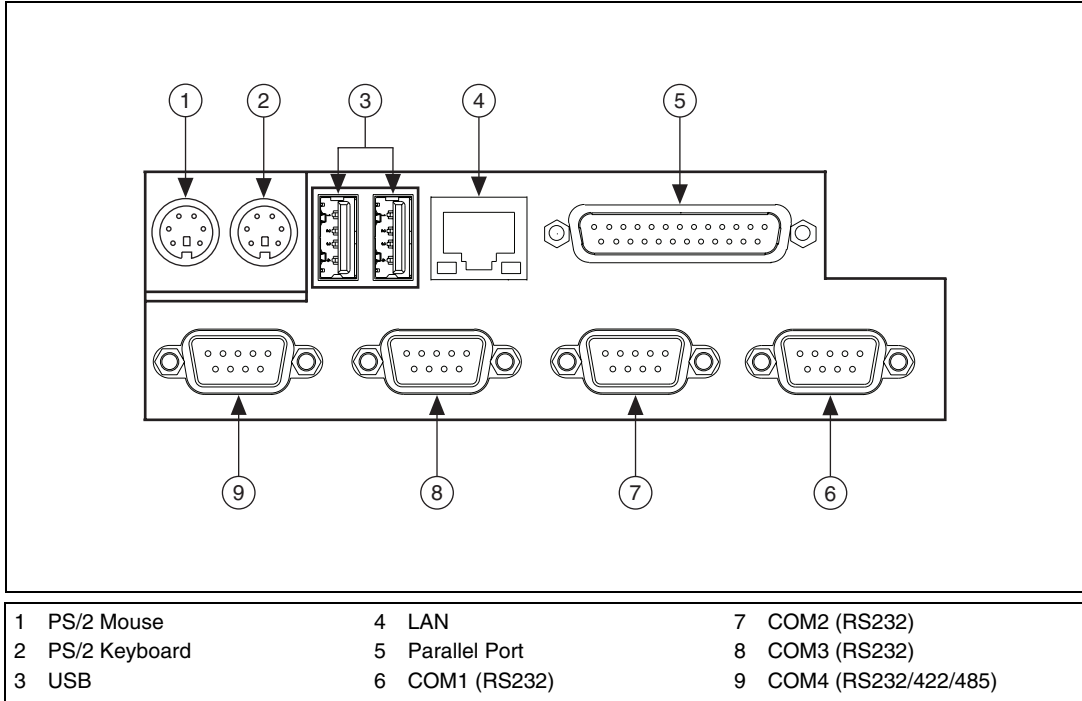

Figure 1-1. I/O Port Arrangement

For more TPC-2012 specifications, see Appendix A, [Specifications](#).

Cleaning

If you need to clean the unit, use a soft, nonmetallic brush. Make sure that the unit is completely dry and free from contaminants before returning it to service.

System Setup

This chapter includes setup information for the TPC-2012.

Important Safety Information

Before setting up the TPC-2012, read these safety instructions carefully.

Disconnect this equipment from any AC outlet before cleaning. Use a damp cloth. Do not use liquid or spray detergents for cleaning.

For plug-in equipment, the power outlet socket must be located near the equipment and must be easily accessible.

Keep this equipment away from excessive humidity.

Place this equipment on a reliable surface during installation. Dropping it or letting it fall may cause damage.

The openings on the enclosure are for air convection. Protect the equipment from overheating. *Do not cover the openings.*

Make sure the power source voltage is correct before connecting the equipment to the power outlet.

Position the power cord so that it cannot be stepped on. Do not place anything over the power cord.

All cautions and warnings on the equipment should be noted.

If the equipment is not used for a long time, disconnect it from the power source to avoid damage by transient overvoltage.

Never pour any liquid into an opening. This may cause fire or electrical shock.

Never open the equipment. For safety reasons, only qualified service personnel should open the equipment.

If one of the following situations arises, have service personnel check the equipment:

- The power cord or plug is damaged.
- Liquid has penetrated into the equipment.
- The equipment has been exposed to moisture.
- The equipment does not work well, or you cannot get it to work according to the user manual.
- The equipment has been dropped and damaged.
- The equipment has obvious signs of breakage.

Do not leave this equipment in an environment where the storage temperature may go below -20°C (-4°F) or above 60°C (140°F). Doing so could damage the equipment. The equipment should be in a controlled environment.



Caution There is a danger of explosion if the battery is incorrectly replaced. Replace the battery only with the same or equivalent type recommended by the manufacturer. Discard used batteries according to the manufacturer's instructions.

The sound pressure level at the operator's position according to IEC 704-1:1982 is no more than 70 dB (A).



Caution The protection this equipment provides may be impaired if it is used in a manner not described in this manual.

Setup

Follow these steps to set up the TPC-2012:

1. Unpack the TPC-2012. Be sure your kit includes the following items:
 - The TPC-2012 HMI
 - Eight panel mounting clamps
 - Eight panel mounting screws
 - One 3-pin power connector
 - One HMI Resource CD
 - One CompactFlash to IDE adapter card

If any items are missing or damaged, contact National Instruments.



Caution Be sure system power is off before plugging in or pulling out the CompactFlash card.

2. Remove the dummy CompactFlash card from the slot in the TPC-2012. Install a CompactFlash card containing Windows CE, embedded Windows XP, or another operating system.
3. Connect the power connector to 24 VDC power lines. Be sure to connect the positive, negative, and ground lines as shown in Figure 2-1. The power lines can be from either a power adapter or in-house power source.

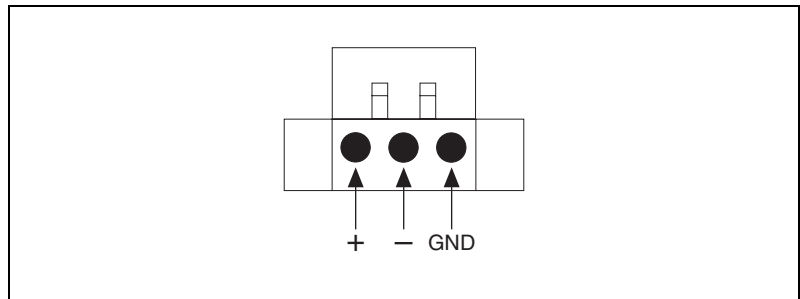

Figure 2-1. Power Connector

4. Connect the power connector to the power receptor on the TPC-2012. The power receptor pin assignment is shown in Figure 2-2.

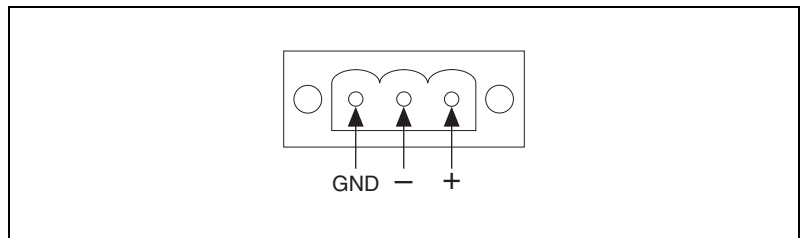

Figure 2-2. Power Receptor and Pin Assignment

5. Switch on the power switch to power on the system.

Touchscreen Calibration

The TPC-2012 touchscreen should be correctly calibrated and ready to use when you power on the system. However, if the calibration is not correct or you want to choose custom calibration options, refer to Appendix F, [Touchscreen Configuration](#).

Panel Mounting

Follow these steps to mount the TPC-2012 in a panel:

1. Be sure the adhesive waterproof gasket on the front bezel is in position.
2. Attach the clamps included in the accessory pack to the holes in the bezel.
3. Install the TPC-2012 in the panel opening.
4. Insert the screws included in the accessory pack into the clamps. Tighten the screws to fasten the TPC-2012 to the panel.



Note The suggested mounting panel thickness is less than 6 mm (0.236 in.).

Jumpers and Connectors

This chapter describes the TPC-2012 jumpers and connectors.

Jumper and Connector Functions

Table 3-1 lists the jumper and connector functions.

Table 3-1. Mainboard Connectors and Jumpers

Label	Function	Description
CN2	LCD power	LCD inverter connector
CN3	CF	CompactFlash socket
CN4	IDE	Internal IDE 44-pin (2 mm) connector
CN5	Ethernet	RJ45 LAN port
CN6	LPT	Printer port
CN7	COM1	Serial port: COM2 RS232
CN8	COM2	Serial port: COM1 RS232
CN9	DC in	DC power in connector (5.08 mm, 3-pin housing)
CN10	USB2	Two USB type-A female
CN11	USB1	Two USB type-A female
CN12	PS2 mouse	Standard mini-DIN 6-pin
CN13	PS2 keyboard	Standard mini-DIN 6-pin
CN14	PCI104	PCI104 30*4 connector
CN15	COM3	Serial port: COM1 RS232
CN16	COM4	Serial port: COM1 RS232/485/422

Table 3-1. Mainboard Connectors and Jumpers (Continued)

Label	Function	Description
JP1	Panel	Panel connector
JP2	Touch	Touch connector
JP4	5 V/3 V	PCI104 5 V/3 V select
J1	DDR	DDR connector
J3	1*3 pin header	Clear CMOS
SW1	Power switch	System power switch
BH1	Battery	RTC battery
FS1	Fuse	Fuse holder

Jumper and Connector Locations

Figures 3-1 and 3-2 show the jumper and connector locations.

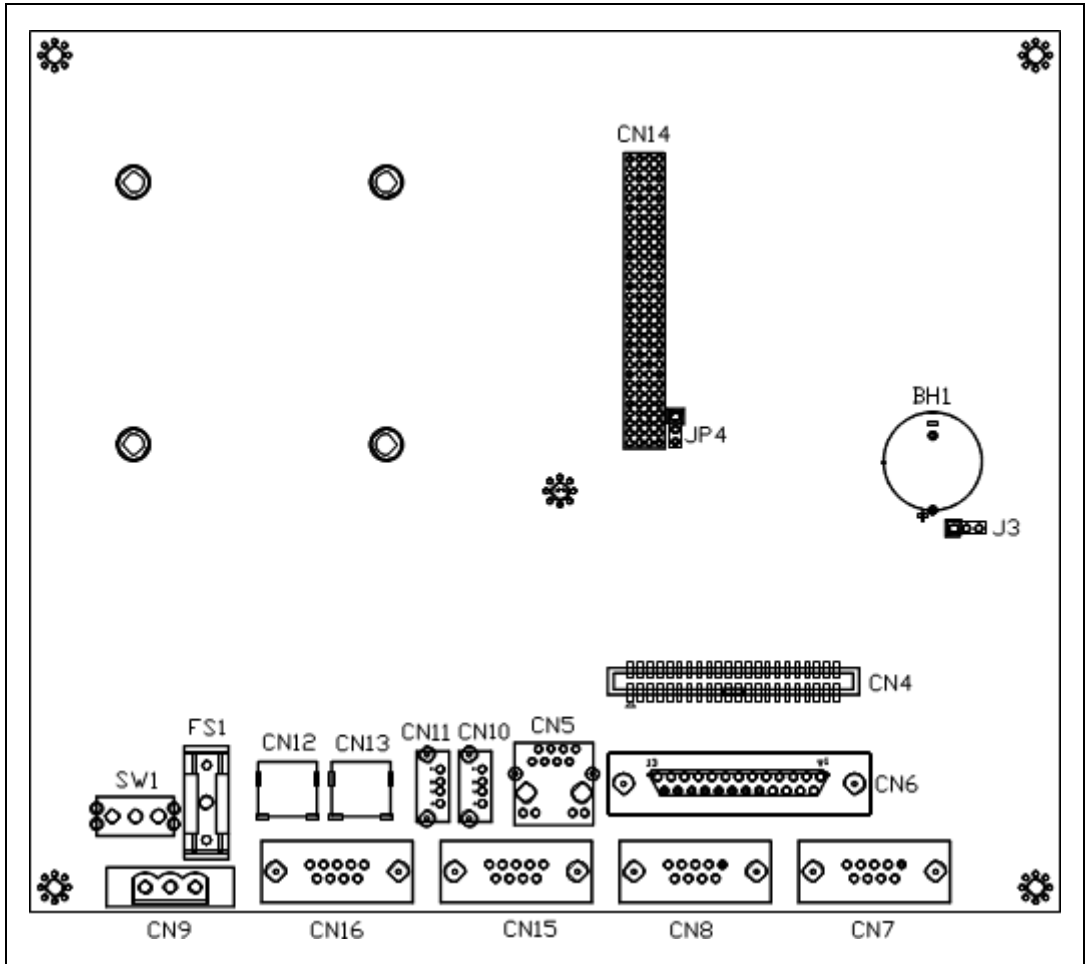

Figure 3-1. Main Board Jumpers and Connectors

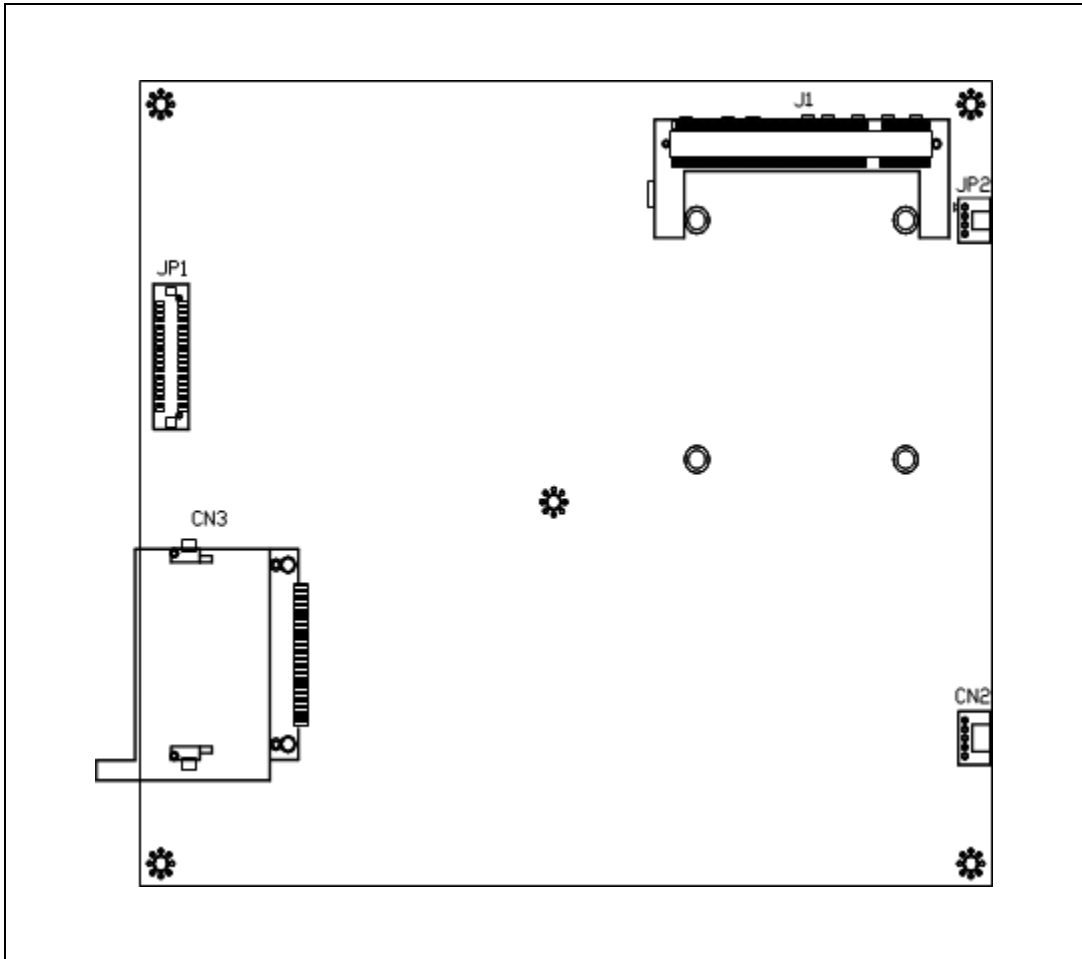

Figure 3-2. Main Board Jumpers and Connectors

Specifications

This appendix lists the TPC-2012 system specifications.

Physical

Weight..... 4.1 kg (without HDD)

Cutout dimensions..... 302 × 228 mm (suggested)

Dimensions

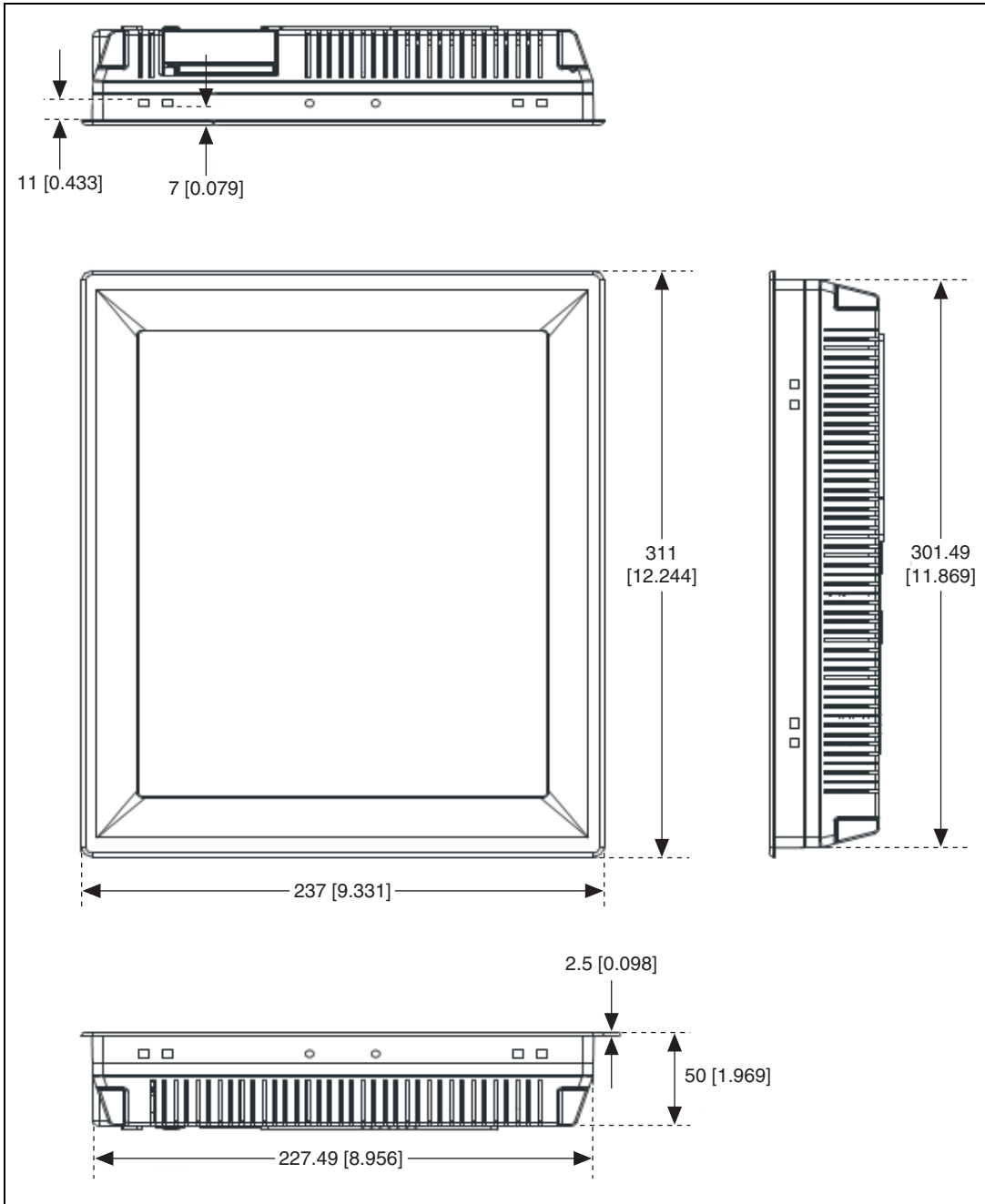

System Kernel

CPU	GeodeLink Control Processor LX800 500 MHz
BIOS.....	Award 512 KB flash memory
South bridge	GeodeLink Control Processor CS5535
VGA	GeodeLink Control Processor LX800 500 MHz
Ethernet	Realtek RTL8100BL; IEEE 802.3u protocol compatible
Watchdog timer	W83627 watchdog timer; 1.6 s timeout period
IDE	1 EIDE channel supports one CompactFlash socket onboard (Master) and one IDE interface hard drive (Slave)



Note COM1 and COM2 support only half-duplex (maximum baud rate: 115.2 Kbps).

LCD

Display type	TFT color LCD
Size (diagonal)	12.1 in.
Maximum resolution	800 × 600 (SVGA)
Maximum colors	256,000
Pixel pitch (W × H, mm).....	0.3075 × 0.3075
Viewing angle	100°
Luminance (cd/m ²)	340
Contrast ratio.....	300
Operating temperature.....	0 to 50 °C (32 to 122 °F) (ambient)

Backlight.....2 CCFL

Backlight lifespan50,000 h



Note There may be several bright or dark pixels on the LCD. This phenomenon is normal in LCD manufacturing.

Touchscreen

Touch typeResistive

Base glass construction.....Tempered Glass

Resolution1024 × 1024

Light transmission75% typical

ControllerUSB interface

Lifespan1 million touches at a single point

Power

Input voltage18 to 32 VDC

Typical24 VDC, 2.0 A

Fuse

Rating.....T3.15 A, 250 V

Size5 × 20 mm



Note For your protection, the fuse is set to break if the input voltage exceeds 33 VDC.

Environment

Operating temperature0 to 50 °C (32 to 122 °F)

Storage temperature-20 to 60 °C (-4 to 140 °F)

Humidity40 °C @ 10 to 95% relative
humidity (noncondensing)

Vibration.....1 grms (5 to 500 Hz)

Maximum altitude 2,000 m

Pollution Degree 2

Indoor use only

Safety

This product is designed to meet the requirements of the following standards of safety for information technology equipment:

- IEC 60950-1, EN 60950-1
- UL 60950-1, CSA 60950-1



Note For UL and other safety certifications, refer to the product label or visit ni.com/certification, search by model number or product line, and click the appropriate link in the Certification column.

Electromagnetic Compatibility

This product is designed to meet the requirements of the following standards of EMC for electrical equipment for measurement, control, and laboratory use:

- EN 55024, CISPR 24 EMC requirements
- EN 55022, CISPR 22 Emissions; Class A
- EN 55011, CISPR 11 Emissions; Class A
- CE, C-Tick, ICES, and FCC Part 15 Emissions; Class A



Note For EMC compliance, operate this device according to product documentation.

CE Compliance

This product meets the essential requirements of applicable European Directives, as amended for CE marking, as follows:

- 73/23/EEC; Low-Voltage Directive (safety)
- 89/336/EEC; Electromagnetic Compatibility Directive (EMC)



Note Refer to the Declaration of Conformity (DoC) for this product for any additional regulatory compliance information. To obtain the DoC for this product, visit ni.com/certification, search by model number or product line, and click the appropriate link in the Certification column.

Waste Electrical and Electronic Equipment (WEEE)



EU Customers At the end of their life cycle, all products *must* be sent to a WEEE recycling center. For more information about WEEE recycling centers and National Instruments WEEE initiatives, visit ni.com/environment/weee.htm.

Cleaning

If you need to clean the unit, use a soft, nonmetallic brush. Make sure that the unit is completely dry and free from contaminants before returning it to service.

Serial Port Settings

This appendix describes the TPC-2012 serial port settings.

COM1/COM2/COM3 Connector Pinout

The following figure and table show the COM1/COM2/COM3 connector pinout.

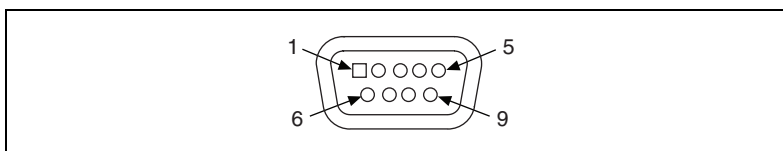

Pin	Signal
1	NDCD
2	NRX
3	NTX
4	NDTR
5	GND
6	NDSR
7	NRTS
8	NCTS
9	NRI



Note COM1 and COM2 support only half-duplex (maximum baud rate: 115.2 Kbps).

COM4 Connector Pinout and Settings

The TPC-2012 COM4 serial port is adjustable. You can set it to RS-232, RS-422, or RS-485, and it has auto data flow control capability. In other words, the TPC-2012 can automatically detect the data flow direction at this port when two-wired RS-485 communication is activated.

The following figure and table show the COM4 pinout and settings.

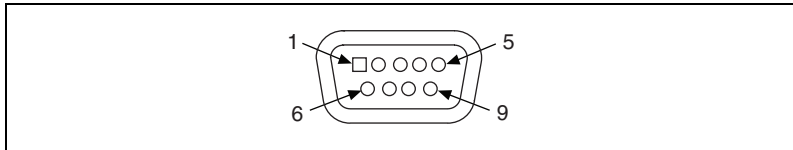

COM4 Mode	S1 and S2 Setting
RS232 Mode	
RS485 Mode	
RS422 Master Mode	
RS422 Slave Mode	

PIN	RS-232	RS-422	RS-485
1	NDCD	TX-	D-
2	NRX	TX+	D+
3	NTX	RX+	
4	NDTR	RX-	
5	GND	GND	GND
6	NDSR		
7	NRTS		
8	NCTS		
9	NRI		



Watchdog Timer Programming

This appendix explains the TPC-2012 watchdog timer programming.

Overview

You can use the TPC-2012 watchdog timer to monitor system software operation and take corrective action if the software fails to function after the programmed period. This appendix describes how to program the watchdog timer operation.

The watchdog timer is built into the W83627HF I/O controller. It includes the following programmable functions:

- You can enable and disable the timer via programming.
- You can set the timer interval from 1 to 255 seconds or 1 to 255 minutes.
- The timer generates an interrupt or resets the signal if the software fails to reset the timer after a timeout.

Watchdog Timer Programming

The watchdog timer I/O port address is 2E (hex) (the address port) and 2F (hex) (the data port). You must first assign the register address by writing the address value to address port 2E (hex), then write/read data to/from the assigned register through data port 2F (hex).

Figure C-1 describes the watchdog timer programming procedure, and Table C-1 describes the watchdog timer registers.

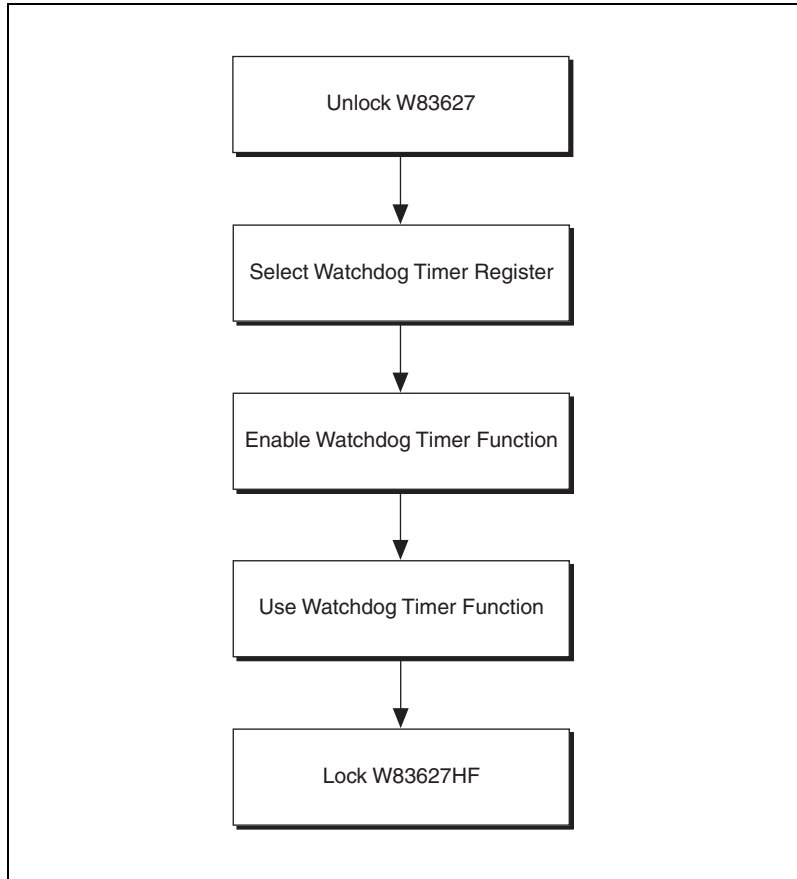

Figure C-1. Watchdog Timer Programming Procedure

Table C-1. Watchdog Timer Registers

Address of Register (2E)	Attribute	Description
Read/Write	Value (2F) and description	—
87 (hex)	—	Write this address twice to I/O address port 2E (hex) to unlock the W83627HF.
07 (hex)	Write	Write 08 (hex) to select the watchdog timer register.

Table C-1. Watchdog Timer Registers (Continued)

Address of Register (2E)	Attribute	Description
30 (hex)	Write	Write 01 (hex) to enable the watchdog timer function. The default is disabled.
F5 (hex)	Write	Set seconds or minutes as the timer unit. Write 0 to bit 3 (default): second. Write 1 to bit 3: minute.
F6 (hex)	Write	0: Stop timer 01 to FF (hex) (default): The count amount, in seconds or minutes, depends on the value set in register F5 (hex). This number determines how long the watchdog timer waits for the strobe before generating an interrupt or reset signal. Writing a new value to this register resets the timer to count with the new value.
F7 (hex)	Read/Write	Bit 6: Write 1 to enable the keyboard to reset the timer. Write 0 to disable. Bit 5 (default): Write 1 to generate a timeout signal immediately and automatically return to 0. Bit 4 (default = 0): Read the watchdog timer status. 1 means the timer is timeout.
AA (hex)	—	Write this address to I/O port 2E (hex) to lock the watchdog timer.

Example Programs

Example 1: Enable the Watchdog Timer and Set 10 s as the Timeout Interval

```

;-----
Mov dx,2eh ; Unlock W83627HF
Mov al,87h
Out dx,al
Out dx,al
;-----
Mov al,07h ; Select registers of watchdog timer
Out dx,al
Inc dx
Mov al,08h
Out dx,al
;-----
Dec dx ; Enable the function of watchdog timer
Mov al,30h
Out dx,al
Inc dx
Mov al,01h
Out dx,al
;-----
Dec dx ; Set second as counting unit
Mov al,0f5h
Out dx,al
Inc dx
In al,dx
And al,not 08h
Out dx,al
;-----
Dec dx ; Set timeout interval as 10 seconds and start counting
Mov al,0f6h
Out dx,al
Inc dx
Mov al,10
Out dx,al
;-----
Dec dx ; lock W83627HF
Mov al,0aah
Out dx,al

```

Example 2: Enable the Watchdog Timer and Set 5 Min as the Timeout Interval

```

;-----
Mov dx,2eh ; unlock W83627H
Mov al,87h
Out dx,al
Out dx,al
;-----
Mov al,07h ; Select registers of watchdog timer
Out dx,al
Inc dx
Mov al,08h
Out dx,al
;-----
Dec dx ; Enable the function of watchdog timer
Mov al,30h
Out dx,al
Inc dx
Mov al,01h
Out dx,al
;-----
Dec dx ; Set minute as counting unit
Mov al,0f5h
Out dx,al
Inc dx
In al,dx
Or al,08h
Out dx,al
;-----
Dec dx ; Set timeout interval as 5 minutes and start counting
Mov al,0f6h
Out dx,al
Inc dx
Mov al,5
Out dx,al
;-----
Dec dx ; lock W83627HF
Mov al,0aah
Out dx,al

```

Example 3: Enable the Mouse to Reset the Watchdog Timer

```

;-----
Mov dx,2eh ; unlock W83627H
Mov al,87h
Out dx,al
Out dx,al
;-----
Mov al,07h ; Select registers of watchdog timer
Out dx,al
Inc dx
Mov al,08h
Out dx,al
;-----
Dec dx ; Enable the function of watchdog timer
Mov al,30h
Out dx,al
Inc dx
Mov al,01h
Out dx,al
;-----
Dec dx ; Enable watchdog timer to be reset by mouse
Mov al,0f7h
Out dx,al
Inc dx
In al,dx
Or al,80h
Out dx,al
;-----
Dec dx ; lock W83627HF
Mov al,0aah
Out dx,al

```

Example 4: Enable the Keyboard to Reset the Watchdog Timer

```

;-----
Mov dx,2eh ; unlock W83627H
Mov al,87h
Out dx,al
Out dx,al
;-----
Mov al,07h ; Select registers of watchdog timer
Out dx,al
Inc dx

```

```

Mov al,08h
Out dx,al
;-----
Dec dx ; Enable the function of watchdog timer
Mov al,30h
Out dx,al
Inc dx
Mov al,01h
Out dx,al
;-----
Dec dx ; Enable watchdog timer to be strobed reset by keyboard
Mov al,0f7h
Out dx,al
Inc dx
In al,dx
Or al,40h
Out dx,al
;-----
Dec dx ; lock W83627HF
Mov al,0aah
Out dx,al

```

Example 5: Generate a Timeout Signal without Timer Counting

```

;-----
Mov dx,2eh ; unlock W83627H
Mov al,87h
Out dx,al
Out dx,al
;-----
Mov al,07h ; Select registers of watchdog timer
Out dx,al
Inc dx
Mov al,08h
Out dx,al
;-----
Dec dx ; Enable the function of watchdog timer
Mov al,30h
Out dx,al
Inc dx
Mov al,01h
Out dx,al
;-----
Dec dx ; Generate a time-out signal

```

```
Mov al,0f7h
Out dx,al ;Write 1 to bit 5 of F7 register
Inc dx
In al,dx
Or al,20h
Out dx,al
;-----
Dec dx ; lock W83627HF
Mov al,0aah
Out dx,al
```

Watchdog Timer Programming on WinCE

Windows CE includes a watchdog timer for the TPC-2012. You can access the timer through the WIN32 API. The TPC-2012 includes a WDT driver, WDT1:, for enabling/disabling the watchdog timer. You must open this driver before using the resources, and then use the DeviceIOControl function to enable/disable the watchdog timer.

This appendix describes DeviceIOControl and its parameters. It also includes a programming example.

DeviceIOControl

DeviceIOControl sends a control code directly to a specified device driver, causing the corresponding device to perform the specified operation. The function and its parameters are:

```
BOOL DeviceIoControl( HANDLE hDevice, DWORD
dwIoControlCode, LPVOID lpInBuffer, DWORD nInBufferSize,
LPVOID lpOutBuffer, DWORD nOutBufferSize, LPDWORD
lpBytesReturned, LPOVERLAPPED lpOverlapped );
```

Parameters

DeviceIOControl includes the following parameters:

- `hDevice`
(in) Handle to the device that performs the operation. Call the `CreateFile` function to obtain a device handle.
- `dwIoControlCode`
(in) Specifies the operation control code. This value identifies the specific operation to be performed and the type of device on which the operation is to be performed. No specific values are defined for the `dwIoControlCode` parameter. However, if you write a custom device driver, you can define `IOCTL_XXXX` control codes, per the `CTL_CODE` macro. You then can advertise these control codes, and an application

can use these control codes with DeviceIoControl to perform driver-specific functions.

- `lpInBuffer`
(in) Long pointer to a buffer that contains the data required to perform the operation. This parameter can be NULL if the `dwIoControlCode` parameter specifies an operation that does not require input data.
- `nInBufferSize`
(in) Size, in bytes, of the buffer pointed to by `lpInBuffer`.
- `lpOutBuffer`
(out) Long pointer to a buffer that receives the operation's output data. This parameter can be NULL if the `dwIoControlCode` parameter specifies an operation that does not produce output data.
- `nOutBufferSize`
(in) Size, in bytes, of the buffer pointed to by `lpOutBuffer`.
- `lpBytesReturned`
(out) Long pointer to a variable that receives the size, in bytes, of the data stored into the buffer pointed to by `lpOutBuffer`. The `lpBytesReturned` parameter cannot be NULL. Even when an operation produces no output data, and `lpOutBuffer` can be NULL, DeviceIoControl makes use of the variable pointed to by `lpBytesReturned`. After such an operation, the variable value has no meaning.
- `lpOverlapped`
(in) Ignored; set to NULL.
- Return Values
Nonzero indicates success. Zero indicates failure. To get extended error information, call `GetLastError`.

How to Use the Control Codes

There are six control codes for the WDT driver operation codes.

IOCTL_WDT_ENABLE

Enables the application watchdog timer. By default, if the watchdog timer is enabled, the WDT driver automatically triggers itself after the specified period, and your application does not need to trigger the watchdog timer.

- lpInBuffer: unused
- nInBufferSize: unused
- lpOutBuffer: unused
- nOutBufferSize: unused

IOCTL_WDT_DISABLE

Disables the application watchdog timer.

- lpInBuffer: unused
- nInBufferSize: unused
- lpOutBuffer: unused
- nOutBufferSize: unused

IOCTL_WDT_STROBE

Triggers the watchdog. If your application uses IOCTL_WDT_ENABLE to enable the watchdog first and then sends IOCTL_WDT_REBOOT to the WDT driver, your application must trigger the watchdog once during the watchdog timer period. If your application has not triggered at the specified period, the device reboots automatically.

- lpInBuffer: unused
- nInBufferSize: unused
- lpOutBuffer: unused
- nOutBufferSize: unused

IOCTL_WDT_GETTIMEOUT

Gets the watchdog time setting.

- lpInBuffer: unused
- nInBufferSize: unused

- `lpOutBuffer`: The DWORD points to your watchdog time setting. The watchdog time settings are:

Setting	Time
0	2 s
1 (default)	5 s (default)
2	10 s
3	15 s
4	30 s
5	45 s
6	60 s

- `nOutBufferSize`: unused

IOCTL_WDT_SETTIMEOUT

Sets the watchdog time setting.

- `lpInBuffer`: The DWORD points to your watchdog time setting. The watchdog time settings are:

Setting	Time
0	2 s
1 (default)	5 s (default)
2	10 s
3	15 s
4	30 s
5	45 s
6	60 s

- `nInBufferSize`: unused
- `lpOutBuffer`: unused
- `nOutBufferSize`: unused

IOCTL_WDT_REBOOT

If you want your application to trigger the watchdog, use `IOCTL_WDT_REBOOT` to notify the watchdog driver timer (WDT). Otherwise, the WDT triggers itself automatically.

- `lpInBuffer`: unused
- `nInBufferSize`: unused
- `lpOutBuffer`: unused
- `nOutBufferSize`: unused

Programming Example

```
#define WDT_CODE(ID) CTL_CODE(FILE_DEVICE_UNKNOWN, ID, METHOD_BUFFERED,
FILE_ANY_ACCESS)
#define IOCTL_WDT_ENABLE WDT_CODE (0x900)
#define IOCTL_WDT_DISABLE WDT_CODE(0x901)
#define IOCTL_WDT_STROBE WDT_CODE(0x902)
#define IOCTL_WDT_GET_TIMEOUT WDT_CODE(0x903)
#define IOCTL_WDT_SET_TIMEOUT WDT_CODE(0x904)
#define IOCTL_WDT_REBOOT WDT_CODE(0x905)
// for compatibility reasons, you can define IOCTL as below:
// #define IOCTL_WDT_ENABLE 0x1001
// #define IOCTL_WDT_DISABLE 0x1002
// #define IOCTL_WDT_STROBE 0x1003
// #define IOCTL_WDT_GETTIMEOUT 0x1004
// #define IOCTL_WDT_SETTIMEOUT 0x1005
// #define IOCTL_WDT_REBOOT 0x1006
HANDLE m_hWDT=NULL;
TCHAR szClassName[60];
// assign the WDT driver name wsprintf(szClassName, TEXT("WDT1:"));
// Open the WDT driver
m_hWDT = CreateFile(szClassName, GENERIC_READ | GENERIC_WRITE, 0, NULL,
OPEN_EXISTING, FILE_ATTRIBUTE_NORMAL, NULL);
if ( m_hWDT == INVALID_HANDLE_VALUE ) { DebugMsg(CString("WDT driver fail"));
return;
}
DWORD dwTemp; DWORD nIndex=2;
// Set the Watchdog Timer as 10 seconds. Number 2 means 10 seconds.
DeviceIoControl(m_hWDT, IOCTL_WDT_SET_TIMEOUT, &nIndex, sizeof(nIndex),
NULL, 0, &dwTemp, NULL);
// Enable the Watchdog timer
DeviceIoControl(m_hWDT, IOCTL_WDT_ENABLE, NULL, 0, NULL, 0, &dwTemp, NULL);
```

```
While (1) {  
    // do your job here.  
    Sleep(8000);  
    DeviceIoControl(m_hWDT, IOCTL_WDT_STROBE, NULL, 0, NULL, 0, &dwTemp, NULL);  
}  
DeviceIoControl(m_hWDT, IOCTL_WDT_DISABLE, NULL, , NULL, 0, &dwTemp, NULL);  
CloseHandle(m_hWDT);
```

Accessory Kit Assembly Procedure

This appendix explains how to connect to a CD-ROM via the CompactFlash slot.

CompactFlash to IDE Transfer Kit Assembly

Follow these steps to connect to a CD-ROM via the CompactFlash slot:

1. Connect the IDE cable to the adapter board.
2. Insert the adapter board into the CompactFlash slot.
3. Connect the CD-ROM to the IDE cable.
4. Connect the external power line to the CD-ROM.

Touchscreen Configuration

This appendix explains how to configure the TPC-2012 touchscreen using the PenMount Control Panel.

Touchscreen Calibration

To calibrate the TPC-2012, go to **Start»Control Panel»Stylus**, which displays the Stylus Properties screen. You can set the double-tap sensitivity in the **Double-Tap** tab. To recalibrate the stylus, use the **Calibration** tab. Press the **Recalibrate** button, then press and briefly hold the stylus on the center of each target as it appears on the screen. When finished, tap on the screen with the stylus to save the settings.

Fuse Replacement



Caution *Do not* replace the fuse unless it is damaged. *Do not* replace the fuse with a differently rated fuse. For more information, see the fuse specifications in Appendix A, *Specifications*.

Follow these steps to replace the fuse:

1. Remove the fuse cover.
2. Replace the damaged fuse with a new one.
3. Place the fuse cover back into position.



Technical Support and Professional Services

Visit the following sections of the National Instruments Web site at ni.com for technical support and professional services:

- **Support**—Online technical support resources at ni.com/support include the following:
 - **Self-Help Resources**—For answers and solutions, visit the award-winning National Instruments Web site for software drivers and updates, a searchable KnowledgeBase, product manuals, step-by-step troubleshooting wizards, thousands of example programs, tutorials, application notes, instrument drivers, and so on.
 - **Free Technical Support**—All registered users receive free Basic Service, which includes access to hundreds of Application Engineers worldwide in the NI Discussion Forums at ni.com/forums. National Instruments Application Engineers make sure every question receives an answer.

For information about other technical support options in your area, visit ni.com/services or contact your local office at ni.com/contact.

- **Training and Certification**—Visit ni.com/training for self-paced training, eLearning virtual classrooms, interactive CDs, and Certification program information. You also can register for instructor-led, hands-on courses at locations around the world.
- **System Integration**—If you have time constraints, limited in-house technical resources, or other project challenges, National Instruments Alliance Partner members can help. To learn more, call your local NI office or visit ni.com/alliance.

If you searched ni.com and could not find the answers you need, contact your local office or NI corporate headquarters. Phone numbers for our worldwide offices are listed at the front of this manual. You also can visit the Worldwide Offices section of ni.com/niglobal to access the branch office Web sites, which provide up-to-date contact information, support phone numbers, email addresses, and current events.

Index

A

accessory kit assembly, E-1

C

CE compliance specifications, A-5

cleaning, 1-2, A-6

COM1/COM2/COM3 connector pinout, B-1

COM4 connector pinout and settings, B-2

CompactFlash to IDE transfer kit

assembly, E-1

connectors, 3-1

function descriptions (table), 3-1

locations (table), 3-3, 3-4

control codes, using, D-3

conventions used in the manual, *v*

D

DeviceIOControl, D-1

control codes

IOCTL_WDT_DISABLE, D-3

IOCTL_WDT_ENABLE, D-3

IOCTL_WDT_GETTIMEOUT, D-3

IOCTL_WDT_REBOOT, D-5

IOCTL_WDT_SETTIMEOUT, D-4

IOCTL_WDT_STROBE, D-3

using, D-3

parameters, D-1

diagnostic tools (NI resources), H-1

dimensions, A-2

documentation

conventions used in the manual, *v*

NI resources, H-1

drivers (NI resources), H-1

E

electromagnetic compatibility
specifications, A-5

environmental specifications, A-4

example programs

watchdog timer, C-4

examples (NI resources), H-1

F

fuse

replacement, G-1

specifications, A-4

H

help, technical support, H-1

I

I/O ports, 1-1

arrangement (figure), 1-2

instrument drivers (NI resources), H-1

introduction, 1-1

IOCTL_WDT_DISABLE, D-3

IOCTL_WDT_ENABLE, D-3

IOCTL_WDT_GETTIMEOUT, D-3

IOCTL_WDT_REBOOT, D-5

IOCTL_WDT_SETTIMEOUT, D-4

IOCTL_WDT_STROBE, D-3

J

jumpers, 3-1

function descriptions (table), 3-1

locations (table), 3-3, 3-4

K

KnowledgeBase, H-1

L

LCD specifications, A-3

N

National Instruments support and services, H-1

P

panel mounting, 2-4

physical specifications, A-1

pinouts

COM1/COM2/COM3 connector, B-1

COM4 connector, B-2

power connector (figure), 2-3

power receptor (figure), 2-3

power specifications, A-4

programming examples (NI resources), H-1

S

safety

information, 2-1

specifications, A-5

serial port settings, B-1

setup, 2-2

software (NI resources), H-1

specifications,

CE compliance, A-5

cleaning, 1-2, A-6

dimensions, A-2

electromagnetic compatibility, A-5

environmental, A-4

fuse, A-4

LCD, A-3

physical, A-1

power, A-4

safety, A-5

system kernel, A-3

touchscreen, A-4

Waste Electrical and Electronic

Equipment compliance, A-6

system kernel specifications, A-3

system setup, 2-2

T

technical support, H-1

touchscreen

calibration, 2-3, F-1

specifications, A-4

TPC-2012

CE compliance specifications, A-5

cleaning specifications, 1-2, A-6

COM1/COM2/COM3 connector

pinout, B-1

COM4 connector pinout and settings, B-2

CompactFlash to IDE transfer kit

assembly, E-1

connectors, 3-1

dimensions, A-2

electromagnetic compatibility

specifications, A-5

environmental specifications, A-4

fuse

replacement, G-1

specifications, A-4

I/O ports, 1-1

introduction, 1-1

jumpers, 3-1

LCD specifications, A-3

panel mounting, 2-4

physical specifications, A-1

power connector (figure), 2-3

power receptor (figure), 2-3

power specifications, A-4

- safety
 - information, 2-1
 - specifications, A-5
- serial port settings, B-1
- specifications, A-1
- system kernel specifications, A-3
- system setup, 2-2
- touchscreen
 - calibration, 2-3
 - specifications, A-4
- Waste Electrical and Electronic Equipment specifications, A-6
- watchdog timer programming, C-1
 - example programs, C-4
 - on Win CE, D-1
 - DeviceIOControl, D-1
 - overview, C-1
 - procedure (figure), C-2
 - registers (table), C-2
- training and certification (NI resources), H-1
- troubleshooting (NI resources), H-1

W

- Waste Electrical and Electronic Equipment compliance specifications, A-6
- watchdog timer programming, C-1
 - example programs, C-4
 - enabling the keyboard to reset the watchdog timer, C-6
 - enabling the mouse to reset the watchdog timer, C-6
 - enabling the watchdog timer and setting 10 seconds as the timeout interval, C-4
 - enabling the watchdog timer and setting 5 minutes as the timeout interval, C-5
 - generating a timeout signal without timer counting, C-7
 - on WinCE, D-1
 - DeviceIOControl, D-1
 - programming example, D-5
 - overview, C-1
 - procedure (figure), C-2
 - registers (table), C-2
- Web resources, H-1