

CALIBRATION PROCEDURE

NI 5152/5153/5154

This document contains instructions for writing an external calibration procedure for National Instruments PXI/PCI-5152/5153/5154 digitizers. This calibration procedure is intended for metrology labs. For more information about calibration, visit ni.com/calibration.

Contents

Conventions	2
Software Requirements	3
Documentation Requirements	4
Password	4
Calibration Interval	5
External Calibration	5
Self-Calibration	5
Test Equipment	5
Test Conditions	7
Calibration Procedures	8
Initial Setup	8
Self-Calibration	8
MAX	9
NI-SCOPE SFP	9
NI-SCOPE	9
Verification	11
Vertical Offset and Vertical Gain Accuracy	11
Programmable Vertical Offset Accuracy (NI 5152 Only)	23
Timing Accuracy	28
Bandwidth	32
Trigger Accuracy	43
Trigger Sensitivity	54
Adjustment	58
Appendix A: Calibration Options	63
Complete Calibration	64
Optional Calibration	65

Appendix B: Calibration Utilities.....	67
MAX.....	67
NI-SCOPE.....	67
Where to Go for Support	68

Conventions

The following conventions appear in this manual:

» The » symbol leads you through nested menu items and dialog box options to a final action. The sequence **File»Page Setup»Options** directs you to pull down the **File** menu, select the **Page Setup** item, and select **Options** from the last dialog box.



This icon denotes a note, which alerts you to important information.



This icon denotes a caution, which advises you of precautions to take to avoid injury, data loss, or a system crash.

bold Bold text denotes items that you must select or click in the software, such as menu items and dialog box options. Bold text also denotes parameter names.

italic Italic text denotes variables, emphasis, a cross-reference, or an introduction to a key concept. Italic text also denotes text that is a placeholder for a word or value that you must supply.

monospace Text in this font denotes text or characters that you should enter from the keyboard, sections of code, programming examples, and syntax examples. This font is also used for the proper names of disk drives, paths, directories, programs, subprograms, subroutines, device names, functions, operations, variables, filenames, and extensions.

Platform Text in this font denotes a specific platform and indicates that the text following it applies only to that platform.

Software Requirements

Calibrating the NI 5152/5153/5154 requires installing the following versions of NI-SCOPE on the calibration system.

Device	NI-SCOPE Version
NI PXI-5152	3.2 or later
NI PCI-5152	3.3 or later
NI PXI/PCI-5153/5154	3.5 or later

You can download NI-SCOPE from the Instrument Driver Network at ni.com/idnet. NI-SCOPE supports programming the [Self-Calibration](#) and [Verification](#) sections in a number of programming languages; however, only LabVIEW and C are supported for the [Adjustment](#) section.

NI-SCOPE includes all the functions and attributes necessary for calibrating the NI 5152/5153/5154. LabVIEW support is installed in `niScopeCal.llb`, and all calibration functions appear in the function palette. For LabWindows™/CVI™, the NI-SCOPE function panel `niScopeCal.fp` provides further help on the functions available in CVI. Refer to Table 1 for installed file locations.

Calibration functions are LabVIEW VIs or C function calls in the NI-SCOPE driver. The C function calls are valid for any compiler capable of calling a 32-bit DLL. Many of the functions use constants defined in the `niScopeCal.h` file. To use these constants in C, you must include `niScopeCal.h` in your code when you write the calibration procedure.

For more information on the calibration VIs functions, refer to the *NI-SCOPE LabVIEW Reference Help* or the *NI-SCOPE Function Reference Help*. These references can be found in the *NI High-Speed Digitizers Help*. Refer to the *NI-SCOPE Readme* for the installed locations of these documents.

Table 1. Calibration File Locations after Installing NI-SCOPE

File Name and Location	Description
<code>IVI\Bin\niscope_32.dll</code>	NI-SCOPE driver containing the entire NI-SCOPE API, including calibration functions
<code>IVI\Lib\msc\niscope.lib</code>	NI-SCOPE library for Microsoft C containing the entire NI-SCOPE API, including calibration functions

Table 1. Calibration File Locations after Installing NI-SCOPE (Continued)

File Name and Location	Description
<LabVIEW>\examples\instr\niScope	Directory of LabVIEW NI-SCOPE example VIs, including self-calibration.
<LabVIEW>\instr.lib\niScope\Calibrate\niScopeCal.llb	LabVIEW VI library containing VIs for calling the NI-SCOPE calibration API.
IVI\Drivers\niScope\niScopeCal.fp	CVI function panel file that includes external calibration function prototypes and help on using NI-SCOPE in the CVI environment.
IVI\Include\niScopeCal.h	Calibration header file, which you must include in any C program accessing calibration functions. This file automatically includes niScope.h, which defines the rest of the NI-SCOPE interface.
IVI\Drivers\niScope\Examples	Directory of NI-SCOPE examples for CVI, C, Visual C++, and Visual Basic.

Documentation Requirements

You may find the following documentation helpful as you write your calibration procedure:

- *NI High-Speed Digitizers Getting Started Guide*
- *NI High-Speed Digitizers Help*
- *NI PXI/PCI-5152 Specifications*
- *NI 5153/5154 Specifications*
- *NI-SCOPE LabVIEW Reference Help (NI-SCOPE VIs and NI-SCOPE Properties)*
- *NI-SCOPE Function Reference Help*

These documents are installed with NI-SCOPE. You can also download the latest versions from ni.com/manuals.

Password

A password is required to open an external calibration session. If the password has not been changed since manufacturing, the password is NI.

Calibration Interval

External Calibration

The measurement accuracy requirements of your application determine how often you should externally calibrate the NI 5152/5153/5154. NI recommends that you perform a complete external calibration at least once every two years. You can shorten this interval based on the accuracy demands of your application. Refer to [Appendix A: Calibration Options](#) for more information.

Self-Calibration

Self-calibration can be performed whenever necessary to compensate for environmental changes.



Caution Although you can use self-calibration repeatedly, self-calibrating the NI 5152/5153/5154 more than a few times a day may cause excessive wear on the relays over time.

Test Equipment

Table 2 lists the equipment required for externally calibrating the NI 5152/5153/5154. If you do not have the recommended instruments, use these specifications to select a substitute calibration standard.

Table 2. Required Equipment Specifications for NI 5152/5153/5154 External Calibration

Required Equipment	Recommended Equipment		Parameter Measured	Specification
Signal Generator	NI 5152/5153: Fluke 9500B oscilloscope calibrator or Wavetek 9500 with high-stability reference option Fluke 9510 Test Head	NI 5154: Fluke 9500B/1100 oscilloscope calibrator or Wavetek 9500/1100 with high-stability reference option Fluke 9510 Test Head	DC Accuracy	DC $\pm(0.025\% + 25 \mu\text{V})$ into 1 M Ω or 50 Ω
			Bandwidth, Trigger Sensitivity	NI 5152: $\pm 2\%$ output amplitude flatness for leveled sine wave up to 300 MHz relative to 50 kHz into 50 Ω NI 5153: $\pm 3\%$ output amplitude flatness for leveled sine wave up to 500 MHz relative to 50 kHz into 50 Ω NI 5154: $\pm 4\%$ output amplitude flatness for leveled sine wave up to 1100 MHz relative to 50 kHz into 50 Ω
			Timing	± 2 ppm frequency accuracy
	NI 5402 Function Generator or Agilent 33220A Function Generator	Trigger Accuracy	$\pm 5\%$ output amplitude flatness for leveled sine wave up to 10 V _{pk-pk} and 11 MHz relative to 50 kHz into 50 Ω	
(3) BNC Cables	—		—	50 Ω , identical in length and cable material

Table 2. Required Equipment Specifications for NI 5152/5153/5154 External Calibration (Continued)

Required Equipment	Recommended Equipment	Parameter Measured	Specification
BNC Power Splitter	Mini-Circuits Power Splitter ZSC 2-1+	Trigger Accuracy	Insertion Loss: < 4 dB at 10 MHz Amplitude Imbalance: 0.2 dB
BNC Feedthrough Terminator	Pomona 4119 BNC Feedthrough Terminator	Trigger Accuracy	50 Ω Frequency Range: DC to 10.1 MHz VSWR: 1.1 at 10 MHz



Note The delay times indicated in this procedure apply specifically to the Fluke 9500B/Wavetek 9500 calibrator. If you use a different instrument, you may need to adjust these delay times.

Test Conditions

Follow these guidelines to optimize the connections and the environment during calibration:

- Always connect the calibrator test head directly to the input BNC of the digitizer, or use a short 50 Ω BNC coaxial cable if necessary. Long cables and wires act as antennae, picking up extra noise that can affect measurements.
- Keep relative humidity between 10 and 90% non-condensing, or consult the digitizer hardware specifications for the optimum relative humidity.
- Maintain an ambient temperature of 23 \pm 5 $^{\circ}$ C.
- Allow a warm-up time of at least 15 minutes after the NI-SCOPE driver is loaded. Unless manually disabled, NI-SCOPE automatically loads with the operating system and enables the device. The warm-up time ensures that the measurement circuitry of the digitizer is at a stable operating temperature.

For PXI digitizers:

- Ensure that the PXI chassis fan speed is set to HIGH, that the fan filters are clean, and that the empty slots contain filler panels. For more information, refer to the *Maintain Forced Air Cooling Note to Users*, which is available at ni.com/manuals.
- Plug the PXI chassis and the calibrator into the same power strip to avoid ground loops.

For PCI digitizers:

- Plug the PC and the calibrator into the same power strip to avoid ground loops.

Calibration Procedures

The calibration process includes the following steps.

1. *Initial Setup*—Install the device and configure it in Measurement & Automation Explorer (MAX).



Note Allow a 15-minute warm-up time before beginning self-calibration.

2. *Self-Calibration*—Adjust the self-calibration constants of the device.
3. *Verification*—Verify the existing operation of the device. This step confirms whether the device is operating within its specified range prior to calibration.
4. *Adjustment*—Perform an external adjustment of the device that adjusts the calibration constants with respect to a known voltage source. The adjustment procedure automatically stores the calibration date on the EEPROM to allow traceability.
5. *Reverification*—Repeat the verification procedure to ensure that the device is operating within its specifications after adjustment.

These steps are described in more detail in the following sections.



Note In some cases, the complete calibration procedure may not be required. Refer to [Appendix A: Calibration Options](#) for more information.

Initial Setup

Refer to the *NI High-Speed Digitizers Getting Started Guide* for information about how to install the software and hardware, and how to configure the device in MAX.

Self-Calibration

The NI 5152/5153/5154 includes precise internal circuits and references used during self-calibration to adjust for time and temperature drift.



Note Allow a 15 minute warm-up period before you begin self-calibration.



Note Self-calibrate the digitizer before you perform verification. NI-SCOPE includes self-calibration example programs for LabVIEW, CVI, and Microsoft Visual C.

You can initiate self-calibration using the following methods:

- MAX
- NI-SCOPE Soft Front Panel (SFP)
- NI-SCOPE

MAX

To initiate self-calibration from MAX, complete the following steps:

1. Disconnect or disable any AC inputs to the digitizer.
2. Launch MAX.
3. Select **My System»Devices and Interfaces»NI-DAQmx Devices**.
4. Select the device that you want to calibrate.
5. Initiate self-calibration using one of the following methods:
 - Click **Self-Calibrate** in the upper right corner of MAX.
 - Right-click the name of the device in the MAX configuration tree and select **Self-Calibrate** from the drop-down menu.

NI-SCOPE SFP

To initiate self-calibration from the NI-SCOPE SFP, complete the following steps:

1. Disconnect or disable any AC inputs to the digitizer.
2. Launch the Scope SFP, which is available at **Start»All Programs»National Instruments»NI-SCOPE»SCOPE Soft Front Panel**
3. Select the device you want to calibrate using the Device Configuration dialog box by selecting **Edit»Device Configuration**.
4. Launch the Calibration dialog box by selecting **Utility»Self Calibration**.
5. Click **OK** to begin self-calibration.

NI-SCOPE

To self-calibrate the digitizer programmatically using NI-SCOPE, complete the following steps:

1. Disconnect or disable any AC inputs to the digitizer.



Note Throughout the procedure, refer to the C/C++ function call parameters for the LabVIEW input values.

- Open a session and obtain a session handle using the niScope Initialize VI.

LabVIEW VI	C/C++ Function Call
	<p>Call <code>niScope_init</code> with the following parameters:</p> <p>vi: The returned session handle that you use to identify the instrument in all subsequent NI-SCOPE driver function calls</p> <p>resourceName: The device name assigned by MAX</p> <p>idQuery: <code>VI_FALSE</code></p> <p>resetDevice: <code>VI_TRUE</code></p>

- Self-calibrate the digitizer using niScope Cal Self Calibrate VI.

LabVIEW VI	C/C++ Function Call
	<p>Call <code>niScope_calSelfCalibrate</code> with the following parameters:</p> <p>sessionHandle: The instrument handle from <code>niScope_init</code></p> <p>channelList: <code>VI_NULL</code></p> <p>option: <code>VI_NULL</code></p>



Note Because the session is a standard session rather than an external calibration session, the new calibration constants are immediately stored in the EEPROM. Therefore, you can include this procedure in any application that uses the digitizer.

- End the session using the niScope Close VI.

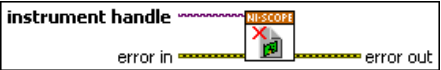
LabVIEW VI	C/C++ Function Call
	<p>Call <code>niScope_close</code> with the following parameters:</p> <p>vi: The instrument handle from <code>niScope_init</code></p>

Verification



Note After the 15 minute warm-up period, always self-calibrate the digitizer before beginning a verification procedure.

This section describes the program you must write to verify the performance of the NI 5152/5153/5154 to either the calibration test limits or the published specifications for the device. Refer to [Appendix A: Calibration Options](#) to determine which limits to use in these procedures.



Note If any of these tests fail immediately after you perform an external adjustment, make sure that you have met the requirements listed in the [Test Equipment](#) and [Test Conditions](#) sections before you return the digitizer to National Instruments for repair.

Vertical Offset and Vertical Gain Accuracy

Table 3 (NI 5152) and Table 4 (NI 5153/5154) contain the input parameters for verifying both vertical offset accuracy and vertical gain accuracy.

To verify vertical offset accuracy, complete the procedures described in the [Vertical Offset Accuracy](#) section for each of the iterations listed in Table 3 (NI 5152) or Table 4 (NI 5153/5154) for channel 0, then repeat the procedures for channel 1. The *Calibration Test Limits* and *Published Specifications* for vertical offset accuracy are shown in Table 5 (NI 5152) and Table 6 (NI 5153/5154).

To verify vertical gain accuracy, complete the procedures described in the [Vertical Gain Accuracy](#) section for each of the iterations listed in Table 3 (NI 5152) and Table 4 (NI 5153/5154) for channel 0, then repeat the procedures for channel 1. The *Calibration Test Limits* and *Published Specifications* for vertical gain accuracy are shown in Table 7 (NI 5152) and Table 8 (NI 5153/5154).

Table 3. NI 5152 Input Parameters for Vertical Offset Accuracy and Vertical Gain Accuracy Verification

Iteration	Input Impedance	Max Input Frequency	Range (V _{pp})
1	50 Ω	300 MHz	0.1
2	50 Ω	300 MHz	0.2
3	50 Ω	300 MHz	0.4
4	50 Ω	300 MHz	1
5	50 Ω	300 MHz	2

Table 3. NI 5152 Input Parameters for Vertical Offset Accuracy and Vertical Gain Accuracy Verification (Continued)

Iteration	Input Impedance	Max Input Frequency	Range (Vpp)
6	50 Ω	300 MHz	4
7	50 Ω	300 MHz	10
8	50 Ω	20 MHz	0.1
9	50 Ω	20 MHz	0.2
10	50 Ω	20 MHz	0.4
11	50 Ω	20 MHz	1
12	50 Ω	20 MHz	2
13	50 Ω	20 MHz	4
14	50 Ω	20 MHz	10
15	1 M Ω	300 MHz	0.1
16	1 M Ω	300 MHz	0.2
17	1 M Ω	300 MHz	0.4
18	1 M Ω	300 MHz	1
19	1 M Ω	300 MHz	2
20	1 M Ω	300 MHz	4
21	1 M Ω	300 MHz	10
22	1 M Ω	20 MHz	0.1
23	1 M Ω	20 MHz	0.2
24	1 M Ω	20 MHz	0.4
25	1 M Ω	20 MHz	1
26	1 M Ω	20 MHz	2
27	1 M Ω	20 MHz	4
28	1 M Ω	20 MHz	10

Table 4. NI 5153/5154 Input Parameters for Vertical Offset Accuracy and Vertical Gain Accuracy Verification

Iteration	NI 5153 Max Input Frequency	NI 5154 Max Input Frequency	Range (Vpp)
1	500 MHz	1 GHz	0.1
2	500 MHz	1 GHz	0.2
3	500 MHz	1 GHz	0.5
4	500 MHz	1 GHz	1
5	500 MHz	1 GHz	2
6	500 MHz	1 GHz	5
7	20 MHz	20 MHz	0.1
8	20 MHz	20 MHz	0.2
9	20 MHz	20 MHz	0.5
10	20 MHz	20 MHz	1
11	20 MHz	20 MHz	2
12	20 MHz	20 MHz	5

Vertical Offset Accuracy

Complete the following steps to verify vertical offset accuracy of the NI 5152/5153/5154. You must verify both channels with each iteration listed in Table 3 (NI 5152) or Table 4 (NI 5153/5154).

1. Open a session and obtain a session handle using the niScope Initialize VI.



Note Throughout the procedure, refer to the C/C++ function call parameters for the LabVIEW input values.

LabVIEW VI	C/C++ Function Call
	<p>Call <code>niScope_init</code> with the following parameters:</p> <p>resourceName: The device name assigned by MAX idQuery: <code>VI_FALSE</code> resetDevice: <code>VI_TRUE</code></p>

2. Configure the input impedance and input frequency for the channel using the niScope Configure Chan Characteristics VI.

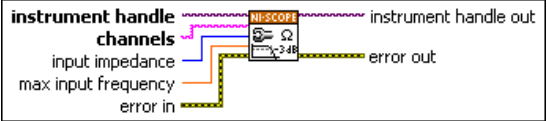
LabVIEW VI	NI-SCOPE Function Call
	<p>Call <code>niScope_ConfigureChan Characteristics</code> with the following parameters:</p> <p>vi: The instrument handle from <code>niScope_init</code> channelList: "0" inputImpedance: The <i>Input Impedance</i> value listed in Table 3 for the current iteration (NI 5152) or <code>NISCOPE_VAL_50_OHM</code> (NI 5153/5154) maxInputFrequency: The <i>Max Input Frequency</i> value listed in Table 3 (NI 5152) or Table 4 (NI 5153/5154) for the current iteration</p>

3. Configure the common vertical properties using the niScope Configure Vertical VI.

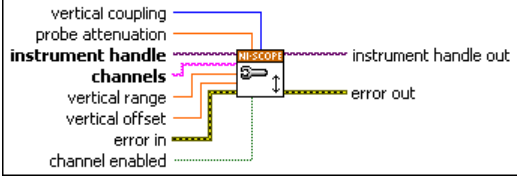
LabVIEW VI	NI-SCOPE Function Call
	<p>Call <code>niScope_ConfigureVertical</code> with the following parameters:</p> <p>vi: The instrument handle from <code>niScope_init</code></p> <p>channelList: "0"</p> <p>range: The <i>Range</i> value listed in Table 3 (NI 5152) or Table 4 (NI 5153/5154) for the current iteration</p> <p>offset: 0.0</p> <p>coupling: <code>NISCOPE_VAL_DC</code></p> <p>probeAttenuation: 1.0</p> <p>enabled: <code>NISCOPE_VAL_TRUE</code></p>

4. Configure the horizontal properties using the niScope Configure Horizontal Timing VI.

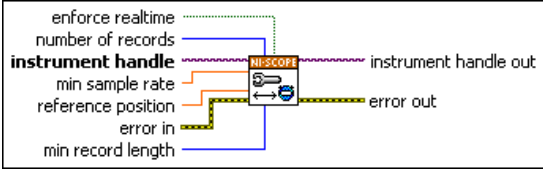
LabVIEW VI	NI-SCOPE Function Call
	<p>Call <code>niScope_ConfigureHorizontalTiming</code> with the following parameters:</p> <p>vi: The instrument handle from <code>niScope_init</code></p> <p>enforceRealtime: <code>NISCOPE_VAL_TRUE</code></p> <p>numRecords: 1</p> <p>minSampleRate: 10,000,000</p> <p>refPosition: 50.0</p> <p>minNumPts: 100,000</p>

5. Commit all the parameter settings to hardware using the niScope Commit VI.

LabVIEW VI	C/C++ Function Call
	<p>Call <code>niScope_Commit</code> with the following parameter:</p> <p>vi: The instrument handle from <code>niScope_init</code></p>

6. Short-circuit the channel 0 input of the digitizer by connecting the calibrator test head directly to the digitizer and grounding the output of the calibrator.
7. Wait 2,500 ms for the impedance matching of the calibrator to settle.



Note If the calibrator stays shorted, you do not need to repeat steps 6 and 7 for every iteration listed in Table 3 (NI 5152) or Table 4 (NI 5153/5154).

8. Initiate a waveform acquisition using the niScope Initiate Acquisition VI.

LabVIEW VI	C/C++ Function Call
	<p>Call <code>niScope_InitiateAcquisition</code> with the following parameter:</p> <p>vi: The instrument handle from <code>niScope_init</code></p>

9. Fetch a waveform from the digitizer and perform a voltage average measurement using the niScope Fetch Measurement (poly) VI. Select the Measurement Scalar DBL instance of the VI.

LabVIEW VI	C/C++ Function Call
	<p>Call <code>niScope_FetchMeasurement</code> with the following parameters:</p> <p>vi: The instrument handle from <code>niScope_init</code></p> <p>timeout: 1.0</p> <p>channelList: "0"</p> <p>scalarMeasFunction: <code>NISCOPE_VAL_VOLTAGE_AVERAGE</code></p>

Compare the resulting average voltage to the value listed under the *Calibration Test Limits* or *Published Specifications* column in Table 5 (NI 5152) or Table 6 (NI 5153/5154) that corresponds to the vertical range used. If the result is within the selected test limit, the device has passed this portion of the verification.



Note The **inputImpedance** and **maxInputFrequency** you configured in step 2 do not affect the test limit value.

10. Repeat steps 2 through 9 for each iteration in Table 3 (NI 5152) or Table 4 (NI 5153/5154).

11. Move the calibrator test head to the channel 1 input of the digitizer, and repeat steps 2 through 10 for every configuration in Table 3 (NI 5152) or Table 4 (NI 5153/5154), changing the value of the **channelList** parameter from "0" to "1".
12. End the session using the niScope Close VI.

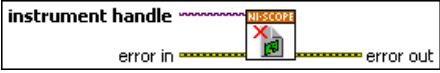
LabVIEW VI	C/C++ Function Call
	Call <code>niScope_close</code> with the following parameters: vi: The instrument handle from <code>niScope_init</code>

You have finished verifying the vertical offset accuracy of the NI 5152/5153/5154.

Table 5. NI 5152 Vertical Offset Calibration Test Limits and Published Specifications

Range (Vpp)	Calibration Test Limits (V)		Published Specification (V)	
	Positive	Negative	Positive	Negative
0.1	0.0006	-0.0006	0.0015	-0.0015
0.2	0.0012	-0.0012	0.0025	-0.0025
0.4	0.0024	-0.0024	0.0045	-0.0045
1	0.006	-0.006	0.0105	-0.0105
2	0.012	-0.012	0.025	-0.025
4	0.024	-0.024	0.045	-0.045
10	0.06	-0.06	0.105	-0.105

Table 6. NI 5153/5154 Vertical Offset Calibration Test Limits and Published Specifications

Range (Vpp)	Calibration Test Limits (V)		Published Specification (V)	
	Positive	Negative	Positive	Negative
0.1	0.00166	-0.00166	0.0018	-0.0018
0.2	0.00331	-0.00331	0.0036	-0.0036
0.5	0.00829	-0.00829	0.009	-0.009
1	0.0166	-0.0166	0.018	-0.018

Table 6. NI 5153/5154 Vertical Offset Calibration Test Limits and Published Specifications (Continued)

Range (Vpp)	Calibration Test Limits (V)		Published Specification (V)	
	Positive	Negative	Positive	Negative
2	0.0331	-0.0331	0.036	-0.036
5	0.0829	-0.0829	0.09	-0.09

Vertical Gain Accuracy

Complete the following steps to verify the vertical gain accuracy of the NI 5152/5153/5154. You must verify both channels with each iteration listed in Table 3 (NI 5152) or Table 4 (NI 5153/5154).

1. Open a session and obtain a session handle using the niScope Initialize VI.

LabVIEW VI	C/C++ Function Call
	<p>Call <code>niScope_init</code> with the following parameters:</p> <p>resourceName: The device name assigned by MAX</p> <p>idQuery: <code>VI_FALSE</code></p> <p>resetDevice: <code>VI_TRUE</code></p>

2. Configure the input impedance and input frequency for the channel using the niScope Configure Chan Characteristics VI.

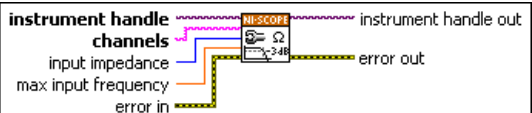
LabVIEW VI	NI-SCOPE Function Call
	<p>Call <code>niScope_ConfigureChanCharacteristics</code> with the following parameters:</p> <p>vi: The instrument handle from <code>niScope_init</code></p> <p>channelList: "0"</p> <p>inputImpedance: The <i>Input Impedance</i> value listed in Table 3 for the current iteration (NI 5152) or <code>NISCOPE_VAL_50_OHM</code> (NI 5153/5154)</p> <p>maxInputFrequency: The <i>Max Input Frequency</i> value listed in Table 3 (NI 5152) or Table 4 (NI 5153/5154) for the current iteration</p>

- Configure the common vertical properties using the niScope Configure Vertical VI.

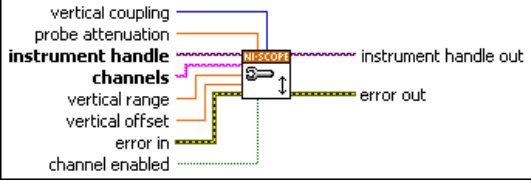
LabVIEW VI	C/C++ Function Call
	<p>Call <code>niScope_ConfigureVertical</code> with the following parameters:</p> <p>vi: The instrument handle from <code>niScope_init</code></p> <p>coupling: <code>NISCOPE_VAL_DC</code></p> <p>probeAttenuation: <code>1.0</code></p> <p>channelList: <code>"0"</code></p> <p>range: The <i>Range</i> value listed in Table 3 (NI 5152) or Table 4 (NI 5153/5154) for the current iteration</p> <p>offset: <code>0.0</code></p> <p>enabled: <code>NISCOPE_VAL_TRUE</code></p>

- Configure the horizontal properties using the niScope Configure Horizontal Timing VI.

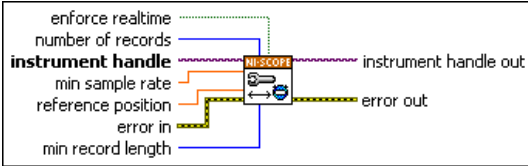
LabVIEW VI	NI-SCOPE Function Call
	<p>Call <code>niScope_ConfigureHorizontalTiming</code> with the following parameters:</p> <p>vi: The instrument handle from <code>niScope_init</code></p> <p>enforceRealtime: <code>NISCOPE_VAL_TRUE</code></p> <p>numRecords: <code>1</code></p> <p>minSampleRate: <code>10,000,000</code></p> <p>refPosition: <code>50.0</code></p> <p>minNumPts: <code>100,000</code></p>

- Commit all the parameter settings to hardware using the niScope Commit VI.

LabVIEW VI	C/C++ Function Call
	<p>Call <code>niScope_Commit</code> with the following parameter:</p> <p>vi: The instrument handle from <code>niScope_init</code></p>

6. Connect the calibrator test head directly to the channel 0 input of the digitizer and output the *Positive Input (V)* in Table 7 (NI 5152) or Table 8 (NI 5153/5154) that corresponds to the vertical range used. Be sure to configure the load impedance of the calibrator to match the input impedance of the digitizer.
7. Wait 2,500 ms for the impedance matching of the calibrator to settle.
8. Initiate a waveform acquisition using the niScope Initiate Acquisition VI.

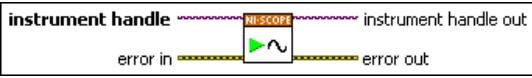
LabVIEW VI	C/C++ Function Call
	<p>Call <code>niScope_InitiateAcquisition</code> with the following parameter:</p> <p>vi: The instrument handle from <code>niScope_init</code></p>

9. Fetch a waveform from the digitizer and perform a voltage average measurement using the niScope Fetch Measurement (poly) VI. Select the Measurement Scalar DBL instance of the VI. The resulting value is the *Measured Positive Input Voltage* used in step 14.

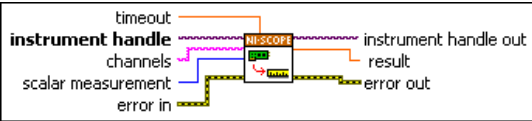
LabVIEW VI	C/C++ Function Call
	<p>Call <code>niScope_FetchMeasurement</code> with the following parameters:</p> <p>vi: The instrument handle from <code>niScope_init</code></p> <p>timeout: 1.0</p> <p>channelList: "0"</p> <p>scalarMeasFunction: NISCOPE_VAL_VOLTAGE_AVERAGE</p>

10. Using the calibrator, output the *Negative Input Voltage* listed in Table 7 (NI 5152) or Table 8 (NI 5153/5154) that corresponds to the vertical range used.
11. Wait 2,500 ms for the impedance matching of the calibrator to settle.

12. Initiate a waveform acquisition using the niScope Initiate Acquisition VI.

LabVIEW VI	C/C++ Function Call
	<p>Call <code>niScope_InitiateAcquisition</code> with the following parameter:</p> <p>vi: The instrument handle from <code>niScope_init</code></p>

13. Fetch a waveform from the digitizer and perform a voltage average measurement using the niScope Fetch Measurement (poly) VI. Select the Measurement Scalar DBL instance of the VI. The resulting value is the *Measured Negative Input Voltage* used in step 14.

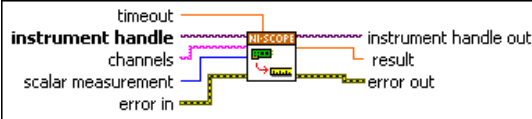
LabVIEW VI	C/C++ Function Call
	<p>Call <code>niScope_FetchMeasurement</code> with the following parameters:</p> <p>vi: The instrument handle from <code>niScope_init</code></p> <p>timeout: 1.0</p> <p>channelList: "0"</p> <p>scalarMeasFunction: <code>NISCOPE_VAL_VOLTAGE_AVERAGE</code></p>

14. Calculate the error in the vertical gain as a percentage of input using the following formula:

$$error = \left(\left(\frac{a-b}{c-d} \right) - 1 \right) \times 100$$

where

a = the *Measured Positive Input Voltage*

b = the *Measured Negative Input Voltage*

c = the applied *Positive Input Voltage*

d = the applied *Negative Input Voltage*

Compare the resulting percent error to the *Calibration Test Limits* or the *Published Specifications* listed in Table 7 (NI 5152) or Table 8 (NI 5153/5154). If the result is within the selected test limit, the device has passed this portion of the verification.

15. Repeat steps 2 through 14 for each iteration in Table 3 (NI 5152) or Table 4 (NI 5153/5154).

16. Move the calibrator test head to the digitizer input channel 1 and repeat steps 2 through 15 for every configuration in Table 3 (NI 5152) or Table 4 (NI 5153/5154), changing the value of the **channelList** parameter from "0" to "1".
17. End the session using the niScope Close VI.

LabVIEW VI	C/C++ Function Call
	Call niScope_close with the following parameter: vi: The instrument handle from niScope_init

Table 7. NI 5152 Vertical Gain Stimuli, Calibration Test Limits, and Published Specifications

Range (V)	Positive Input (V)	Negative Input (V)	Calibration Test Limits		Published Specifications	
			Positive	Negative	Positive	Negative
0.1	0.045	-0.045	1.00%	-1.00%	1.26%	-1.26%
0.2	0.09	-0.09	1.00%	-1.00%	1.26%	-1.26%
0.4	0.18	-0.18	1.00%	-1.00%	1.26%	-1.26%
1	0.45	-0.45	1.00%	-1.00%	1.26%	-1.26%
2	0.9	-0.9	1.00%	-1.00%	1.26%	-1.26%
4	1.8	-1.8	1.00%	-1.00%	1.26%	-1.26%
10	4.5	-4.5	1.00%	-1.00%	1.26%	-1.26%

Table 8. NI 5153/5154 Vertical Gain Stimuli, Calibration Test Limits, and Published Specifications

Range (Vpp)	Positive Input (V)	Negative Input (V)	Calibration Test Limits		Published Specifications	
			Positive	Negative	Positive	Negative
0.1	0.045	-0.045	1.025%	-1.025%	2.200%	-2.200%
0.2	0.09	-0.09	1.025%	-1.025%	2.200%	-2.200%
0.5	0.225	-0.225	1.025%	-1.025%	2.200%	-2.200%
1	0.45	-0.45	1.025%	-1.025%	2.200%	-2.200%

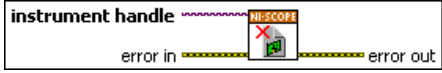
Table 8. NI 5153/5154 Vertical Gain Stimuli, Calibration Test Limits, and Published Specifications (Continued)

Range (Vpp)	Positive Input (V)	Negative Input (V)	Calibration Test Limits		Published Specifications	
			Positive	Negative	Positive	Negative
2	0.9	-0.9	1.732%	-1.732%	2.900%	-2.900%
5	2.25	-2.25	1.732%	-1.732%	2.900%	-2.900%

You have finished verifying the vertical gain accuracy of the NI 5152/5153/5154.

Programmable Vertical Offset Accuracy (NI 5152 Only)

Complete the following steps to verify the programmable vertical offset accuracy for each NI 5152 channel.

1. Open a session and obtain a session handle using the niScope Initialize VI.

LabVIEW VI	C/C++ Function Call
	<p>Call <code>niScope_init</code> with the following parameters:</p> <p>resourceName: The device name assigned by MAX idQuery: <code>VI_FALSE</code> resetDevice: <code>VI_TRUE</code></p>

2. Configure the input impedance and the maximum input frequency using the niScope Configure Chan Characteristics VI.

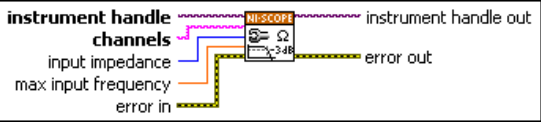
LabVIEW VI	C/C++ Function Call
	<p>Call <code>niScope_ConfigureChan Characteristics</code> with the following parameters:</p> <p>vi: The instrument handle from <code>niScope_init</code> channelList: "0" inputImpedance: <code>NISCOPE_VAL_1_MEG_OHM</code> maxInputFrequency: 20,000,000</p>

3. Configure the common vertical properties using the niScope Configure Vertical VI.

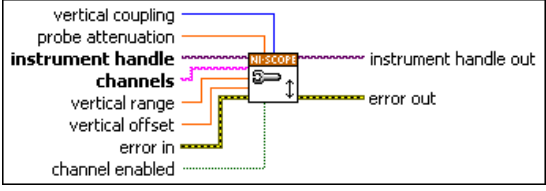
LabVIEW VI	C/C++ Function Call
	<p>Call <code>niScope_ConfigureVertical</code> with the following parameters:</p> <p>vi: The instrument handle from <code>niScope_init</code></p> <p>coupling: <code>NISCOPE_VAL_DC</code></p> <p>probeAttenuation: <code>1.0</code></p> <p>channelList: <code>"0"</code></p> <p>range: The <i>Range</i> value listed in Table 9 for the current iteration</p> <p>offset: The <i>Positive Offset</i> value listed in Table 9 for the current iteration</p> <p>enabled: <code>NISCOPE_VAL_TRUE</code></p>

4. Configure the horizontal properties using the niScope Configure Horizontal Timing VI.

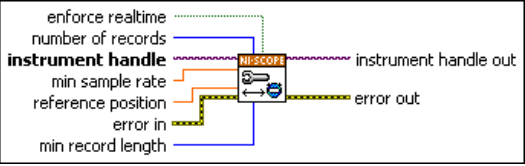
LabVIEW VI	C/C++ Function Call
	<p>Call <code>niScope_ConfigureHorizontalTiming</code> with the following parameters:</p> <p>vi: The instrument handle from <code>niScope_init</code></p> <p>enforceRealtime: <code>NISCOPE_VAL_TRUE</code></p> <p>numRecords: <code>1</code></p> <p>minSampleRate: <code>10,000,000</code></p> <p>refPosition: <code>50.0</code></p> <p>minNumPts: <code>100,000</code></p>

5. Commit all the parameter settings to hardware using the niScope Commit VI.

LabVIEW VI	C/C++ Function Call
	<p>Call <code>niScope_Commit</code> with the following parameter:</p> <p>vi: The instrument handle from <code>niScope_init</code></p>

6. Connect the calibrator test head directly to the channel 0 input of the digitizer.
7. Output the *Positive Offset* voltage listed in Table 9 for the current iteration with a 1 M Ω load impedance.
8. Wait 2,500 ms for the impedance matching of the calibrator to settle.
9. Initiate a waveform acquisition using the niScope Initiate Acquisition VI.

LabVIEW VI	C/C++ Function Call
	<p>Call <code>niScope_Initiate Acquisition</code> with the following parameter:</p> <p>vi: The instrument handle from <code>niScope_init</code></p>

10. Fetch a waveform from the digitizer and perform a voltage average measurement using the niScope Fetch Measurement (poly) VI. Select the Measurement Scalar DBL instance of the VI. The resulting value is the *Measured Positive Input Voltage* used in step 17.

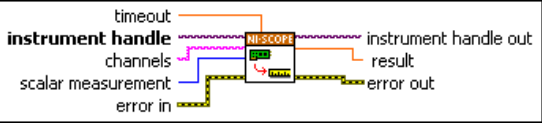
LabVIEW VI	C/C++ Function Call
	<p>Call <code>niScope_FetchMeasurement</code> with the following parameters:</p> <p>vi: The instrument handle from <code>niScope_init</code></p> <p>timeout: 1.0</p> <p>channelList: "0"</p> <p>scalarMeasFunction: <code>NISCOPE_VAL_VOLTAGE_AVERAGE</code></p>

11. Configure the common vertical properties using the niScope Configure Vertical VI.

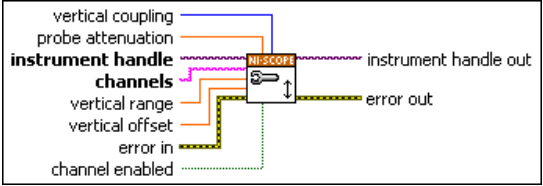
LabVIEW VI	C/C++ Function Call
	<p>Call <code>niScope_ConfigureVertical</code> with the following parameters:</p> <p>vi: The instrument handle from <code>niScope_init</code></p> <p>coupling: <code>NISCOPE_VAL_DC</code></p> <p>probeAttenuation: <code>1.0</code></p> <p>channelList: <code>"0"</code></p> <p>range: The <i>Range</i> value listed in Table 9 for the current iteration</p> <p>offset: The <i>Negative Offset</i> value listed in Table 9 for the current iteration</p> <p>enabled: <code>NISCOPE_VAL_TRUE</code></p>

12. Commit all the parameter settings to hardware using the niScope Commit VI.

LabVIEW VI	C/C++ Function Call
	<p>Call <code>niScope_Commit</code> with the following parameter:</p> <p>vi: The instrument handle from <code>niScope_init</code></p>

13. With the calibrator, output the *Negative Offset* voltage listed in Table 9 for the current iteration, with a 1 M Ω load impedance.
14. Wait 2,500 ms for the impedance matching of the calibrator to settle.
15. Initiate a waveform acquisition using the niScope Initiate Acquisition VI.

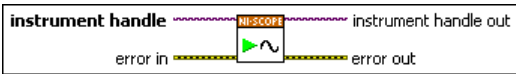
LabVIEW VI	C/C++ Function Call
	<p>Call <code>niScope_InitiateAcquisition</code> with the following parameter:</p> <p>vi: The instrument handle from <code>niScope_init</code></p>

16. Fetch a waveform from the digitizer and perform a voltage average measurement using the niScope Fetch Measurement (poly) VI. Select the Measurement Scalar DBL instance of the VI. The resulting value is the *Measured Negative Input Voltage* used in step 17.

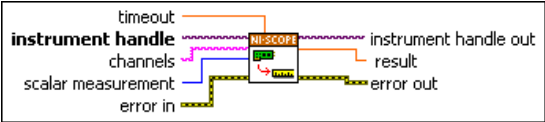
LabVIEW VI	C/C++ Function Call
	<p>Call <code>niScope_FetchMeasurement</code> with the following parameters:</p> <p>vi: The instrument handle from <code>niScope_init</code> timeout: 1.0 channelList: "0" scalarMeasFunction: NISCOPE_VAL_VOLTAGE_AVERAGE</p>

17. Calculate the error in the programmable vertical offset as a percentage of input using the formula:

$$error = \left(\left(\frac{a-b}{c-d} \right) - 1 \right) \times 100$$

where

a = the *Measured Positive Input Voltage*

b = the *Measured Negative Input Voltage*

c = the applied *Positive Offset*

d = the applied *Negative Offset*

Compare the resulting percent to the *Calibration Test Limits* or the *Published Specifications* listed in Table 9. If the result is within the selected test limit, the device has passed this portion of the verification.

18. Repeat steps 2 through 17 for each iteration in Table 9.
19. Move the calibrator test head to the channel 1 input of the digitizer and repeat steps 2 through 18, changing the **channelList** parameter from "0" to "1".
20. End the session using the niScope Close VI.

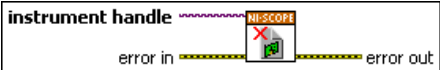
LabVIEW VI	C/C++ Function Call
	<p>Call <code>niScope_close</code> with the following parameters:</p> <p>vi: The instrument handle from <code>niScope_init</code></p>

You have finished verifying the programmable vertical offset accuracy of the NI 5152.

Table 9. NI 5152 Programmable Vertical Offset Accuracy Limits

Iteration	Range (Vpp)	Positive Offset (V)	Negative Offset (V)	Calibration Test Limits		Published Specifications	
				Positive	Negative	Positive	Negative
1	0.1	0.9	-0.9	0.8%	-0.8%	0.9%	-0.9%
2	0.2	0.9	-0.9	0.8%	-0.8%	0.9%	-0.9%
3	0.4	0.9	-0.9	0.8%	-0.8%	0.9%	-0.9%
4	1	0.9	-0.9	0.8%	-0.8%	0.9%	-0.9%
5	2	9	-9	0.8%	-0.8%	0.9%	-0.9%
6	4	9	-9	0.8%	-0.8%	0.9%	-0.9%
7	10	9	-9	0.8%	-0.8%	0.9%	-0.9%

Timing Accuracy

Complete the following steps to verify the timing accuracy for the NI 5152/5153/5154.

1. Open a session and obtain a session handle using the niScope Initialize VI.

LabVIEW VI	C/C++ Function Call
	<p>Call <code>niScope_init</code> with the following parameters:</p> <p>resourceName: The device name assigned by MAX</p> <p>idQuery: <code>VI_FALSE</code></p> <p>resetDevice: <code>VI_TRUE</code></p>

- Configure the input impedance and the maximum input frequency using the niScope Configure Chan Characteristics VI.

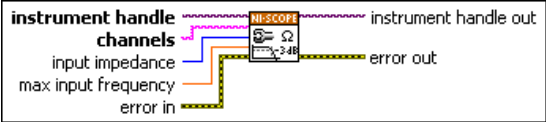
LabVIEW VI	C/C++ Function Call
	<p>Call <code>niScope_ConfigureChanCharacteristics</code> with the following parameters:</p> <p>vi: The instrument handle from <code>niScope_init</code> channelList: "0" inputImpedance: <code>NISCOPE_VAL_50_OHM</code> maxInputFrequency: 20,000,000</p>

- Configure the common vertical properties using the niScope Configure Vertical VI.

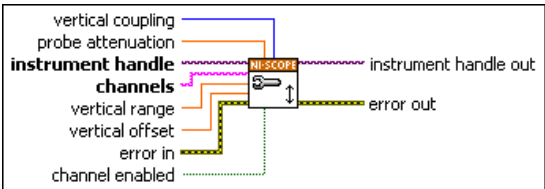
LabVIEW VI	C/C++ Function Call
	<p>Call <code>niScope_ConfigureVertical</code> with the following parameters:</p> <p>coupling: <code>NISCOPE_VAL_DC</code> probeAttenuation: 1.0 vi: The instrument handle from <code>niScope_init</code> channelList: "0" range: 2.0 offset: 0.0 enabled: <code>NISCOPE_VAL_TRUE</code></p>

- Configure the horizontal properties using the niScope Configure Horizontal Timing VI.

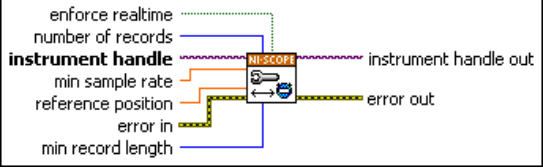
LabVIEW VI	C/C++ Function Call
	<p>Call <code>niScope_ConfigureHorizontalTiming</code> with the following parameters:</p> <p>enforceRealtime: NISCOPE_VAL_TRUE numRecords: 1 vi: The instrument handle from <code>niScope_init</code> minSampleRate: 250,000,000 refPosition: 50.0 minNumPts: 2,500,000</p>

- Commit all the parameter settings to hardware using the niScope Commit VI.

LabVIEW VI	C/C++ Function Call
	<p>Call <code>niScope_Commit</code> with the following parameter:</p> <p>vi: The instrument handle from <code>niScope_init</code></p>

- Connect the scope calibrator test head directly to the channel 0 input of the digitizer. Configure the calibrator to output an exact 11 MHz sine wave with 1 V_{pk-pk} amplitude and 50 Ω load impedance.
- Wait 2,500 ms for the impedance matching and frequency of the calibrator to settle.
- Initiate a waveform acquisition using the niScope Initiate Acquisition VI.

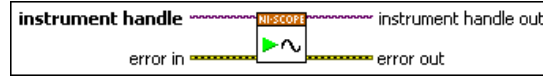
LabVIEW VI	C/C++ Function Call
	<p>Call <code>niScope_InitiateAcquisition</code> with the following parameter:</p> <p>vi: The instrument handle from <code>niScope_init</code></p>

- Retrieve a waveform using the niScope Fetch (poly) VI. Select the WDT instance of the VI. Use the default value (absolute) for the **timestamp Type** parameter.

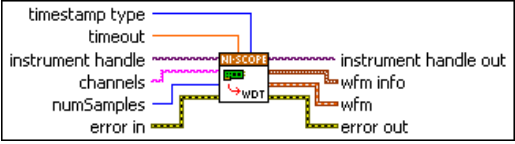
LabVIEW VI	C/C++ Function Call
	<p>Call <code>niScope_Fetch</code> with the following parameter:</p> <p>vi: The instrument handle from <code>niScope_init</code> channelList: "0" timeout: 5.0 numsamples: -1</p>

- Measure the exact frequency of the peak around 11 MHz using the Extract Single Tone Information VI with the following inputs.
 - advanced search»approx freq.:** -1
 - advanced search»search:** 5
 - export signals:** 0 (none)

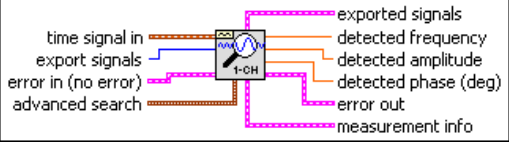
LabVIEW Block Diagram	C/C++ Function Call
	<p>Perform an FFT on the array of data from step 9.</p>

- Calculate the error in timing as parts per million (ppm) using the following formula:

$$error = (a - 11,000,000) / 11$$

where a = the measured frequency.

Compare the result to the *Calibration Test Limits* or the *Published Specifications* listed in Table 10. If the result is within the selected test limit, the device has passed this portion of the verification.



Note The same time source is used for both channel 0 and channel 1, so you only need to verify the timing accuracy on one channel.

12. End the session using the niScope Close VI.

LabVIEW VI	C/C++ Function Call
	<p>Call <code>niScope_close</code> with the following parameters:</p> <p>vi: The instrument handle from <code>niScope_init</code></p>

You have finished verifying the timing accuracy of the NI 5152/5153/5154.

Table 10. Timing Accuracy

Device	Calibration Test Limit	Published Specification
NI 5152	18.5 ppm	25 ppm
NI 5153/5154	18.5 ppm	30 ppm

Bandwidth

Complete the following steps to verify the bandwidth of the NI 5152/5153/5154. You must verify both channels with each iteration listed in Table 11 (NI 5152), Table 12 (NI 5153), or Table 13 (NI 5154).

1. Open a session and obtain a session handle using the niScope Initialize VI.

LabVIEW VI	C/C++ Function Call
	<p>Call <code>niScope_init</code> with the following parameters:</p> <p>resourceName: The device name assigned by MAX</p> <p>idQuery: <code>VI_FALSE</code></p> <p>resetDevice: <code>VI_TRUE</code></p>

- Configure the input impedance and the maximum input frequency using the niScope Configure Chan Characteristics VI.

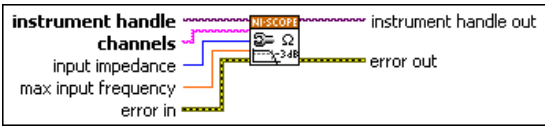
LabVIEW VI	C/C++ Function Call
	<p>Call <code>niScope_ConfigureChanCharacteristics</code> with the following parameters:</p> <p>vi: The instrument handle from <code>niScope_init</code></p> <p>channelList: "0"</p> <p>inputImpedance: The <i>Input Impedance</i> value from Table 11 (NI 5152), Table 12 (NI 5153), or Table 13 (NI 5154) for the current iteration</p> <p>maxInputFrequency: The <i>Max Input Frequency</i> value listed in Table 11 (NI 5152), Table 12 (NI 5153), or Table 13 (NI 5154) for the current iteration</p>

- Configure the common vertical properties using the niScope Configure Vertical VI.

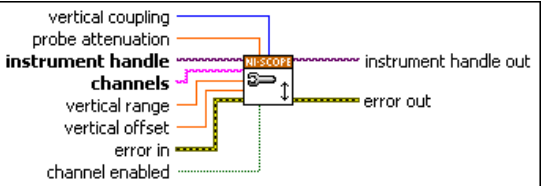
LabVIEW VI	C/C++ Function Call
	<p>Call <code>niScope_ConfigureVertical</code> with the following parameters:</p> <p>vi: The instrument handle from <code>niScope_init</code></p> <p>coupling: <code>NISCOPE_VAL_DC</code></p> <p>probeAttenuation: 1.0</p> <p>channelList: "0"</p> <p>range: The <i>Range</i> value listed in Table 11 (NI 5152), Table 12 (NI 5153), or Table 13 (NI 5154) for the current iteration</p> <p>offset: 0.0</p> <p>enabled: <code>NISCOPE_VAL_TRUE</code></p>

4. Configure the horizontal properties using the niScope Configure Horizontal Timing VI.

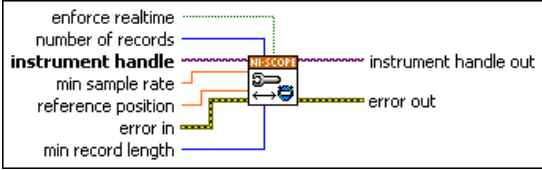
LabVIEW VI	C/C++ Function Call
	<p>Call <code>niScope_ConfigureHorizontalTiming</code> with the following parameters:</p> <p>enforceRealtime: <code>NISCOPE_VAL_TRUE</code> numRecords: 1 vi: The instrument handle from <code>niScope_init</code> minSampleRate: 10,000,000 refPosition: 50.0 minNumPts: 30,000</p>

5. Commit all the parameter settings to hardware using the niScope Commit VI.

LabVIEW VI	C/C++ Function Call
	<p>Call <code>niScope_Commit</code> with the following parameter:</p> <p>vi: The instrument handle from <code>niScope_init</code></p>

- Connect the scope calibrator test head directly to the channel 0 input of the digitizer. Configure the calibrator to output a 51 kHz sine wave with peak-to-peak voltage amplitude set to *Input Voltage* listed in Table 11 (NI 5152), Table 12 (NI 5153), or Table 13 (NI 5154).
Configure the load impedance of the calibrator to match the input impedance of the digitizer.
- Wait 2,500 ms for the impedance matching and frequency of the calibrator to settle.
- Initiate a waveform acquisition using the niScope Initiate Acquisition VI.

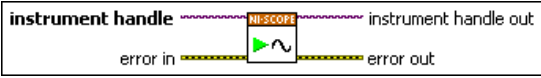
LabVIEW VI	C/C++ Function Call
	<p>Call <code>niScope_InitiateAcquisition</code> with the following parameter:</p> <p>vi: The instrument handle from <code>niScope_init</code></p>

- Fetch a waveform from the digitizer and perform a voltage RMS measurement using the niScope Fetch Measurement (poly) VI. Select the Measurement Scalar DBL instance of the VI. The resulting value is the *Measured RMS Voltage of 51 kHz Sine Wave* used in step 17.

LabVIEW VI	C/C++ Function Call
	<p>Call <code>niScope_FetchMeasurement</code> with the following parameters:</p> <p>vi: The instrument handle from <code>niScope_init</code> timeout: 1.0 channelList: "0" scalarMeasFunction: <code>NISCOPE_VAL_VOLTAGE_RMS</code></p>

- Configure the horizontal properties using the niScope Configure Horizontal Timing VI.

LabVIEW VI	C/C++ Function Call
	<p>Call <code>niScope_ConfigureHorizontalTiming</code> with the following parameters:</p> <p>vi: The instrument handle from <code>niScope_init</code> enforceRealtime: <code>NISCOPE_VAL_TRUE</code> numRecords: 1 minSampleRate: The <i>Sample Rate</i> value listed in Table 11 (NI 5152), Table 12 (NI 5153), or Table 13 (NI 5154) for the current iteration refPosition: 50.0 minNumPts: 300,000</p>

11. Set Time Interleaved Sampling using the niScope Property Node.

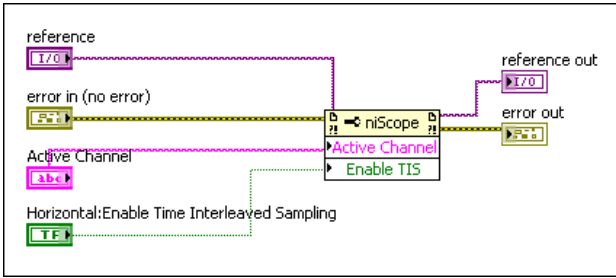
LabVIEW VI	C/C++ Function Call
	<p>Call <code>niScope_SetAttribute ViBoolean</code> with the following parameters:</p> <p>vi: The instrument handle from <code>niScope_init</code> channelList: "0" attributeID: <code>NISCOPE_ATTR_ENABLE_TIME_INTERLEAVED_SAMPLING</code> value: The <i>TIS Enabled</i> value listed in Table 11 (NI 5152), Table 12 (NI 5153), or Table 13 (NI 5154) for the current iteration</p>

12. Commit all the parameter settings to hardware using the niScope Commit VI.

LabVIEW VI	C/C++ Function Call
	<p>Call <code>niScope_Commit</code> with the following parameter:</p> <p>vi: The instrument handle from <code>niScope_init</code></p>

13. Configure the calibrator to output the *Input Frequency* listed in Table 11 (NI 5152), Table 12 (NI 5153), or Table 13 (NI 5154) for the current iteration.
14. Wait 2,500 ms for the impedance matching of the calibrator to settle.
15. Initiate a waveform acquisition using the niScope Initiate Acquisition VI.

LabVIEW VI	C/C++ Function Call
	<p>Call <code>niScope_Initiate Acquisition</code> with the following parameter:</p> <p>vi: The instrument handle from <code>niScope_init</code></p>

16. Fetch a waveform from the digitizer and perform a voltage RMS measurement using the niScope Fetch Measurement (poly) VI. Select the Measurement Scalar DBL instance of the VI. The resulting value is the *Measured RMS Voltage of Generated Sine Wave* used in step 17.

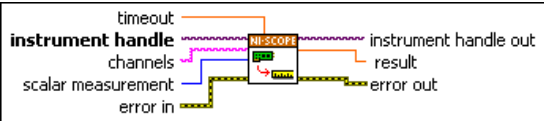
LabVIEW VI	C/C++ Function Call
	<p>Call <code>niScope_FetchMeasurement</code> with the following parameters:</p> <p>vi: The instrument handle from <code>niScope_init</code></p> <p>timeout: 1.0</p> <p>channelList: "0"</p> <p>scalarMeasFunction: NISCOPE_VAL_VOLTAGE_RMS</p>

17. Calculate the power difference using the following formula:

$$\text{power} = (20\log_{10} a) - (20\log_{10} b)$$

where

a = the *Measured RMS Voltage of Generated Sine Wave*

b = the *Measured RMS Voltage of 51 kHz Sine Wave*

If the result is within the test limits in Table 11 (NI 5152), Table 12 (NI 5153), or Table 13 (NI 5154), the device has passed this portion of the verification.

18. Disable Time Interleaved Sampling using the niScope Property Node.

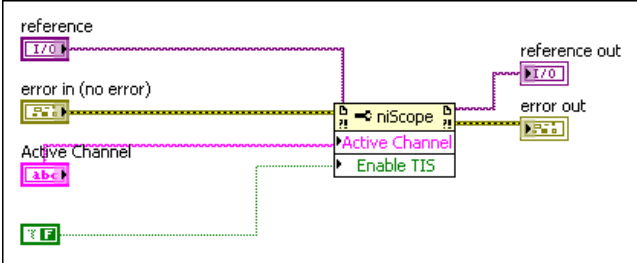
LabVIEW VI	C/C++ Function Call
	<p>Call <code>niScope_SetAttributeViBoolean</code> with the following parameters:</p> <p>vi: The instrument handle from <code>niScope_init</code></p> <p>channelList: "0"</p> <p>attributeID: NISCOPE_ATTR_ENABLE_TIME_INTERLEAVED_SAMPLING</p> <p>value: NISCOPE_VAL_FALSE</p>

19. Repeat steps 2 through 18 for each iteration in Table 11 (NI 5152), Table 12 (NI 5153), or Table 13 (NI 5154).

20. Move the calibrator test head to the channel 1 input of the digitizer and repeat steps 2 through 19, changing value of the **channelList** parameter from "0" to "1".
21. End the session using the niScope Close VI.

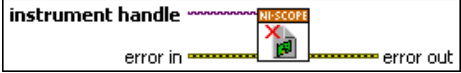
LabVIEW VI	C/C++ Function Call
	<p>Call <code>niScope_close</code> with the following parameters:</p> <p>vi: The instrument handle from <code>niScope_init</code></p>

You have finished verifying the bandwidth of the NI 5152/5153/5154.

Table 11. NI 5152 Bandwidth Stimuli and Limits

Iteration	Input Impedance	Max Input Frequency (MHz)	Range (V _{pp})	Input Frequency (MHz)	Input Voltage (V _{pp})	TIS Enabled	Sample Rate	Published Specifications	
								Max Level (dB)	Min Level (dB)
1	50 Ω	300	0.1	135	0.05	NISCOPE_VAL_FALSE	1 GS/s	N/A	-3
2	50 Ω	300	0.2	301	0.1	NISCOPE_VAL_FALSE	1 GS/s	N/A	-3
3	50 Ω	300	0.4	301	0.2	NISCOPE_VAL_FALSE	1 GS/s	N/A	-3
4	50 Ω	300	1	301	0.5	NISCOPE_VAL_FALSE	1 GS/s	N/A	-3
5	50 Ω	300	2	301	1	NISCOPE_VAL_FALSE	1 GS/s	N/A	-3
6	50 Ω	300	4	301	2	NISCOPE_VAL_FALSE	1 GS/s	N/A	-3
7	50 Ω	300	10	301	5	NISCOPE_VAL_FALSE	1 GS/s	N/A	-3
8	1 MΩ	300	0.1	110	0.05	NISCOPE_VAL_FALSE	1 GS/s	N/A	-3
9	1 MΩ	300	0.2	260	0.1	NISCOPE_VAL_FALSE	1 GS/s	N/A	-3
10	1 MΩ	300	0.4	260	0.2	NISCOPE_VAL_FALSE	1 GS/s	N/A	-3
11	1 MΩ	300	1	260	0.5	NISCOPE_VAL_FALSE	1 GS/s	N/A	-3
12	1 MΩ	300	2	260	1	NISCOPE_VAL_FALSE	1 GS/s	N/A	-3

Table 11. NI 5152 Bandwidth Stimuli and Limits (Continued)

Iteration	Input Impedance	Max Input Frequency (MHz)	Range (V _{pp})	Input Frequency (MHz)	Input Voltage (V _{pp})	TIS Enabled	Sample Rate	Published Specifications	
								Max Level (dB)	Min Level (dB)
13	1 MΩ	300	4	260	2	NISCOPE_ VAL_FALSE	1 GS/s	N/A	-3
14	1 MΩ	300	10	260	5	NISCOPE_ VAL_FALSE	1 GS/s	N/A	-3
15	50 Ω	20	1	18.8	0.5	NISCOPE_ VAL_FALSE	1 GS/s	N/A	-3*
16	50 Ω	20	1	21.8	0.5	NISCOPE_ VAL_FALSE	1 GS/s	-2.5*	N/A

* Published specifications value listed for validation of noise filter only. The specification is not included in the device specifications document.

Table 12. NI 5153 Bandwidth Stimuli and Limits

Iteration	Input Impedance	Max Input Frequency (MHz)	Range (V _{pp})	Input Frequency (MHz)	Input Voltage (V _{pp})	TIS Enabled	Sample Rate	Published Specifications	
								Max Level (dB)	Min Level (dB)
1	50 Ω	500 MHz	0.1	501	0.05	NISCOPE_ VAL_FALSE	1 GS/s	N/A	-3
2	50 Ω	500 MHz	0.1	501	0.05	NISCOPE_ VAL_TRUE	2 GS/s	N/A	-3
3	50 Ω	500 MHz	0.2	501	0.1	NISCOPE_ VAL_FALSE	1 GS/s	N/A	-3
4	50 Ω	500 MHz	0.5	501	0.25	NISCOPE_ VAL_FALSE	1 GS/s	N/A	-3
5	50 Ω	500 MHz	1	501	0.5	NISCOPE_ VAL_FALSE	1 GS/s	N/A	-3
6	50 Ω	500 MHz	2	501	1.0	NISCOPE_ VAL_FALSE	1 GS/s	N/A	-3
7	50 Ω	500 MHz	2	501	1.0	NISCOPE_ VAL_TRUE	2 GS/s	N/A	-3
8	50 Ω	500 MHz	5	501	2.5	NISCOPE_ VAL_FALSE	1 GS/s	N/A	-3
9	50 Ω	20 MHz	2	19.1	1.0	NISCOPE_ VAL_FALSE	1 GS/s	N/A	-3*
10	50 Ω	20 MHz	2	21.1	1.0	NISCOPE_ VAL_FALSE	1 GS/s	-2.5*	N/A

* Published specifications value listed for validation of noise filter only. The specification is not included in the device specifications document.

Table 13. NI 5154 Bandwidth Stimuli and Limits

Iteration	Input Impedance	Max Input Frequency	Range (Vpp)	Input Frequency	Input Voltage (Vpp)	TIS Enabled	Sample Rate	Published Specifications	
								Max Level (dB)	Min Level (dB)
1	50 Ω	1 GHz	0.1	1.001 GHz	0.05	NISCOPE_ VAL_FALSE	1 GS/s	N/A	-3
2	50 Ω	1 GHz	0.1	1.001 GHz	0.05	NISCOPE_ VAL_TRUE	2 GS/s	N/A	-3
3	50 Ω	1 GHz	0.2	300 MHz	0.1	NISCOPE_ VAL_FALSE	1 GS/s	N/A	-3
4	50 Ω	1 GHz	0.5	1.001 GHz	0.25	NISCOPE_ VAL_FALSE	1 GS/s	N/A	-3
5	50 Ω	1 GHz	1	1.001 GHz	0.5	NISCOPE_ VAL_FALSE	1 GS/s	N/A	-3
6	50 Ω	1 GHz	2	1.001 GHz	1.0	NISCOPE_ VAL_FALSE	1 GS/s	N/A	-3
7	50 Ω	1 GHz	2	1.001 GHz	1.0	NISCOPE_ VAL_TRUE	2 GS/s	N/A	-3
8	50 Ω	1 GHz	5	1.001 GHz	2.5	NISCOPE_ VAL_FALSE	1 GS/s	N/A	-3
9	50 Ω	20 MHz	2	19.1 MHz	1.0	NISCOPE_ VAL_FALSE	1 GS/s	N/A	-3*
10	50 Ω	20 MHz	2	21.1 MHz	1.0	NISCOPE_ VAL_FALSE	1 GS/s	-2.5*	N/A

* Published specifications value listed for validation of noise filter only. The specification is not included in the device specifications document.

Trigger Accuracy

Complete the following steps to verify the trigger accuracy for channel 0, channel 1, and the external trigger channel of the NI 5152/5153/5154.

1. Open a session and obtain a session handle using the niScope Initialize VI.

LabVIEW VI	C/C++ Function Call
	<p>Call <code>niScope_init</code> with the following parameters:</p> <p>resourceName: The device name assigned by MAX</p> <p>idQuery: <code>VI_FALSE</code></p> <p>resetDevice: <code>VI_TRUE</code></p>

2. Configure the input impedance and the maximum input frequency using the niScope Configure Chan Characteristics VI.

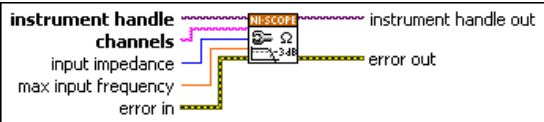
LabVIEW VI	C/C++ Function Call
	<p>Call <code>niScope_ConfigureChanCharacteristics</code> with the following parameters:</p> <p>vi: The instrument handle from <code>niScope_init</code></p> <p>channelList: The <i>Channel List</i> value in Table 14 (NI 5152) or Table 15 (NI 5153/5154) for the current iteration</p> <p>inputImpedance: <code>NISCOPE_VAL_50_OHM</code></p> <p>maxInputFrequency: 300,000,000 (NI 5152) 500,000,000 (NI 5153) 1,000,000,000 (NI 5154)</p>

3. Configure the common vertical properties using the niScope Configure Vertical VI.

LabVIEW VI	C/C++ Function Call
	<p>Call <code>niScope_ConfigureVertical</code> with the following parameters:</p> <p>vi: The instrument handle from <code>niScope_init</code></p> <p>coupling: <code>NISCOPE_VAL_DC</code></p> <p>probeAttenuation: <code>1.0</code></p> <p>channelList: The <i>ChannelList</i> value listed in Table 14 (NI 5152) or Table 15 (NI 5153/5154) for the current iteration</p> <p>range: The <i>Range</i> value listed in Table 14 (NI 5152) or Table 15 (NI 5153/5154) for the current iteration</p> <p>offset: <code>0.0</code></p> <p>enabled: <code>NISCOPE_VAL_TRUE</code></p>

4. Configure the horizontal properties using the niScope Configure Horizontal Timing VI.

LabVIEW VI	NI-SCOPE Function Call
	<p>Call <code>niScope_ConfigureHorizontalTiming</code> with the following parameters:</p> <p>vi: The instrument handle from <code>niScope_init</code></p> <p>enforceRealtime: <code>NISCOPE_VAL_FALSE</code></p> <p>numRecords: <code>1</code></p> <p>minSampleRate: <code>20,000,000,000</code></p> <p>refPosition: <code>0.0</code></p> <p>minNumPts: <code>2,000</code></p>

- Configure the number of averages for each bin in an RIS acquisition using the niScope Property Node.

LabVIEW VI	C/C++ Function Call
	<p>Call <code>niScope_SetAttributeViInt32</code> with the following parameters:</p> <p>vi: The instrument handle from <code>niScope_init</code></p> <p>channelList: The <i>Channel List</i> value in Table 14 (NI 5152) or Table 15 (NI 5153/5154) for the current iteration</p> <p>attributeID: <code>NISCOPE_ATTR_RIS_NUM_AVERAGES</code></p> <p>value: <code>100.0</code></p>

- Configure an edge trigger using the niScope Configure Trigger (poly) VI. Select the Analog Edge Ref Trigger instance of the VI.

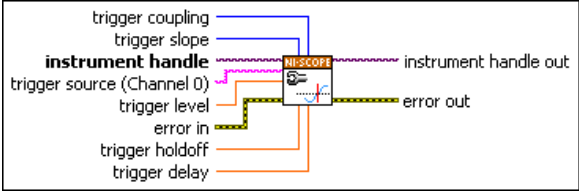
LabVIEW VI	C/C++ Function Call
	<p>Call <code>niScope_ConfigureTriggerEdge</code> with the following parameters:</p> <p>vi: The instrument handle from <code>niScope_init</code></p> <p>triggerCoupling: <code>NISCOPE_VAL_DC</code></p> <p>slope: The <i>Trigger Slope</i> value listed in Table 14 (NI 5152) or Table 15 (NI 5153/5154) for the current iteration</p> <p>triggerSource: The <i>Trigger Source</i> value listed in Table 14 (NI 5152) or Table 15 (NI 5153/5154) for the current iteration</p> <p>level: <code>0</code></p> <p>holdoff: <code>0</code></p> <p>delay: <code>0</code></p>

- Commit all the parameter settings to hardware using the niScope Commit VI.

LabVIEW VI	C/C++ Function Call
	<p>Call <code>niScope_Commit</code> with the following parameter:</p> <p>vi: The instrument handle from <code>niScope_init</code></p>

8. Connect the signal generator to the digitizer input as follows for the current **ChannelList** value:
 - Channel 0 and Channel 1
 - Connect the signal generator directly to the digitizer input for the channel you are testing.
 - External Trigger
 - Place a 50 Ω feedthrough terminator on the trigger input of the digitizer.
 - Connect a cable from the power splitter to the channel 0 input of the digitizer.
 - Connect a cable from the 50 Ω feedthrough terminator to the power splitter.
 - Connect a cable from the output of the signal generator to the power splitter.
9. Configure the signal generator to 50 Ω impedance and output a 10,001,000 Hz sine wave with the *Sine Wave Amplitude* value listed in Table 14 (NI 5152) or Table 15 (NI 5153/5154) for the current iteration.
10. Wait the amount of time the manufacturer recommends for the output of the signal generator to settle.
11. Initiate a waveform acquisition using the niScope Initiate Acquisition VI.

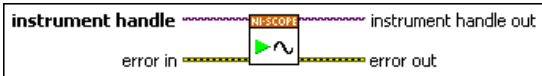
LabVIEW VI	C/C++ Function Call
	<p>Call <code>niScope_InitiateAcquisition</code> with the following parameter:</p> <p>vi: The instrument handle from <code>niScope_init</code></p>

12. Acquire a waveform using the niScope Fetch (poly) VI. Select the Cluster instance of the VI. The first point in the waveform array is the *Measured Trigger Offset* used in step 19 of this section, and in step 5 of the *Trigger Sensitivity* section.

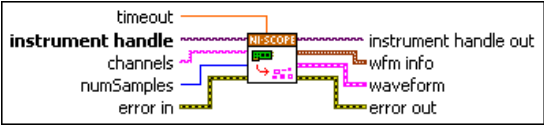
LabVIEW VI	C/C++ Function Call
	<p>Call niScope_Fetch with the following parameter:</p> <p>vi: The instrument handle from niScope_init</p> <p>timeout: 2.0</p> <p>channelList: The <i>Channel List</i> value in Table 14 (NI 5152) or Table 15 (NI 5153/5154) for the current iteration</p> <p>numSamples: -1</p>

13. Configure an edge trigger using the niScope Configure Trigger (poly) VI. Select the Analog Edge Ref Trigger instance of the VI.

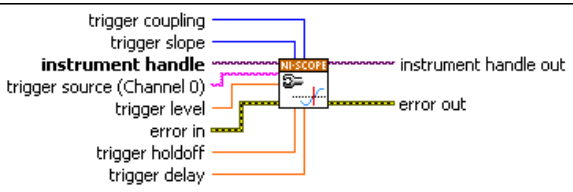
LabVIEW VI	C/C++ Function Call
	<p>Call niScope_ConfigureTriggerEdge with the following parameters:</p> <p>vi: The instrument handle from niScope_init</p> <p>triggerCoupling: NISCOPE_VAL_DC</p> <p>slope: The <i>Trigger Slope</i> value listed in Table 14 (NI 5152) or Table 15 (NI 5153/5154) for the current iteration</p> <p>triggerSource: The <i>Trigger Source</i> value listed in Table 14 (NI 5152) or Table 15 (NI 5153/5154)</p> <p>level: The <i>Positive Trigger Level</i> value in Table 14 (NI 5152) or Table 15 (NI 5153/5154) for the current iteration</p> <p>holdoff: 0</p> <p>delay: 0</p>

14. Initiate a waveform acquisition using the niScope Initiate Acquisition VI.

LabVIEW VI	C/C++ Function Call
	<p>Call <code>niScope_InitiateAcquisition</code> with the following parameter:</p> <p>vi: The instrument handle from <code>niScope_init</code></p>

15. Acquire a waveform using the niScope Fetch (poly) VI. Select the Cluster instance of the VI. The first point in the waveform array is the *Measured Positive Trigger Gain* used in step 19.

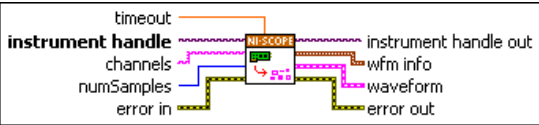
LabVIEW VI	C/C++ Function Call
	<p>Call <code>niScope_Fetch</code> with the following parameter:</p> <p>vi: The instrument handle from <code>niScope_init</code></p> <p>timeout: 2.0</p> <p>channelList: The <i>ChannelList</i> value listed in Table 14 (NI 5152) or Table 15 (NI 5153/5154) for the current iteration</p> <p>numSamples: -1</p>

16. Configure an edge trigger using the niScope Configure Trigger (poly) VI. Select the Analog Edge Ref Trigger instance of the VI.

LabVIEW VI	C/C++ Function Call
	<p>Call <code>niScope_ConfigureTriggerEdge</code> with the following parameters:</p> <p>vi: The instrument handle from <code>niScope_init</code></p> <p>triggerCoupling: <code>NISCOPE_VAL_DC</code></p> <p>slope: The <i>Trigger Slope</i> value in Table 14 (NI 5152) or Table 15 (NI 5154) for the current iteration</p> <p>triggerSource: The <i>Trigger Source</i> value listed in Table 14 (NI 5152) or Table 15 (NI 5153/5154) for the current iteration</p> <p>level: The <i>Negative Trigger Level</i> value in Table 14 (NI 5152) or Table 15 (NI 5153/5154) for the current iteration</p> <p>holdoff: "0"</p> <p>delay: "0"</p>

17. Initiate a waveform acquisition using the niScope Initiate Acquisition VI.

LabVIEW VI	C/C++ Function Call
	<p>Call <code>niScope_InitiateAcquisition</code> with the following parameter:</p> <p>vi: The instrument handle from <code>niScope_init</code></p>

18. Acquire a waveform using the niScope Fetch (poly) VI. Select the Cluster instance of the VI. The first point in the waveform array is the *Measured Negative Trigger Gain* used in step 19.

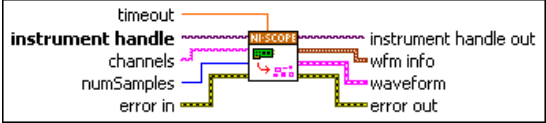
LabVIEW VI	C/C++ Function Call
	<p>Call niScope_Fetch with the following parameter:</p> <p>vi: The instrument handle from niScope_init</p> <p>timeout: 2.0</p> <p>channelList: The <i>ChannelList</i> value listed in Table 14 (NI 5152) or Table 15 (NI 5153/5154) for the current iteration</p> <p>numSamples: -1</p>

19. Calculate the error in the trigger accuracy as a percentage of full scale using the following formula:

$$error = \left| \frac{a \times 100}{b} \right| + \left| \frac{\left(\frac{c-d}{e-f} - 1 \right) \times 100}{2} \right|$$

where

- a = the *Measured Trigger Offset*
- b = the *Range* value listed in Table 14 (NI 5152) or Table 15 (NI 5153/5154) for the current iteration. **Note:** Change the range value used to 10 Vpp when the trigger source is set to NISCOPE_VAL_EXTERNAL.
- c = the *Measured Positive Trigger Gain*
- d = the *Measured Negative Trigger Gain*
- e = the *Positive Trigger Level*
- f = the *Negative Trigger Level*

Compare the resulting percent to the *Calibration Test Limits* or the *Published Specifications* listed in Table 14 (NI 5152) or Table 15 (NI 5154). If the result is within the selected test limit, the device has passed this portion of the verification.

20. Repeat steps 2 through 19, for each iteration in Table 14 (NI 5152) or Table 15 (NI 5153/5154).
21. End the session using the niScope Close VI.

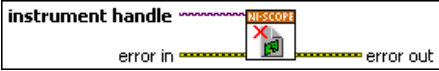
LabVIEW VI	C/C++ Function Call
	<p>Call <code>niScope_close</code> with the following parameters:</p> <p>vi: The instrument handle from <code>niScope_init</code></p>

You have finished verifying the trigger accuracy for the NI 5152/5153/5154.

Table 14. NI 5152 Trigger Accuracy

Iteration	Channel List	Trigger Source	Range (Vpp)	Sine Wave Amplitude (Vpp)	Trigger Level (V)		Trigger Slope	Calibration Test Limits	Published Specifications
					Positive	Negative			
1	0	0	1	0.95	0.35	-0.35	NISCOPE_ VAL_ POSITIVE	±4.7%	±5.0%
2							NISCOPE_ VAL_ NEGATIVE		
3	1	1	1	0.95	0.35	-0.35	NISCOPE_ VAL_ POSITIVE	±9.7%	±10.0%
4							NISCOPE_ VAL_ NEGATIVE		
5	0	NISCOPE_ VAL_ EXTERNAL	10	10	2.6	-2.6	NISCOPE_ VAL_ POSITIVE	±9.7%	±10.0%
6							NISCOPE_ VAL_ NEGATIVE		

Table 15. NI 5153/5154 Trigger Accuracy

Iteration	Channel List	Trigger Source	Range (Vpp)	Sine Wave Amplitude (Vpp)	Trigger Level (V)		Trigger Slope	Calibration Test Limits	Published Specifications
					Positive	Negative			
1	0	0	1	0.95	0.35	-0.35	NISCOPE_VAL_POSITIVE	±4.7%	±5.0%
2							NISCOPE_VAL_NEGATIVE		
3	1	1	1	0.95	0.35	-0.35	NISCOPE_VAL_POSITIVE	±9.7%	±10.0%
4							NISCOPE_VAL_NEGATIVE		
5	0	NISCOPE_VAL_EXTERNAL	5	7	1.78	-1.78	NISCOPE_VAL_POSITIVE	±9.7%	±10.0%
6							NISCOPE_VAL_NEGATIVE		

Trigger Sensitivity

Complete the following steps to verify the trigger sensitivity of the NI 5152/5153/5154. You must verify channel 0, channel 1, and the external trigger channel using the corresponding iterations listed in Table 16. Use the following inputs:

- For channel 0, use the entries for iterations 1 and 2.
 - For channel 1, use the entries for iterations 3 and 4.
 - For the external trigger channel, use the entries for iterations 5 and 6.
1. Open a session and obtain a session handle using the niScope Initialize VI.

LabVIEW VI	C/C++ Function Call
	<p>Call <code>niScope_init</code> with the following parameters:</p> <p>resourceName: The device name assigned by MAX</p> <p>idQuery: <code>VI_FALSE</code></p> <p>resetDevice: <code>VI_TRUE</code></p>

2. Configure the input impedance and the maximum input frequency using the niScope Configure Chan Characteristics VI.

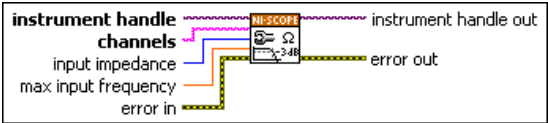
LabVIEW VI	C/C++ Function Call
	<p>Call <code>niScope_ConfigureChanCharacteristics</code> with the following parameters:</p> <p>vi: The instrument handle from <code>niScope_init</code></p> <p>channelList: The <i>channelList</i> value from Table 16 for the current iteration.</p> <p>inputImpedance: <code>NISCOPE_VAL_50_OHM</code></p> <p>maxInputFrequency: 300,000,000 (NI 5152) 500,000,000 (NI 5153) 1,000,000,000 (NI 5154)</p>

- Configure the common vertical properties using the niScope Configure Vertical VI.

LabVIEW VI	C/C++ Function Call
	<p>Call <code>niScope_ConfigureVertical</code> with the following parameters:</p> <p>vi: The instrument handle from <code>niScope_init</code></p> <p>coupling: <code>NISCOPE_VAL_DC</code></p> <p>probeAttenuation: <code>1.0</code></p> <p>channelList: The <i>channelList</i> value from Table 16 for the current iteration.</p> <p>range: <code>1</code></p> <p>offset: <code>0.0</code></p> <p>enabled: <code>NISCOPE_VAL_TRUE</code></p>

- Configure the horizontal properties using the niScope Configure Horizontal Timing VI.

LabVIEW VI	C/C++ Function Call
	<p>Call <code>niScope_ConfigureHorizontalTiming</code> with the following parameters:</p> <p>vi: The instrument handle from <code>niScope_init</code></p> <p>enforceRealtime: <code>NISCOPE_VAL_TRUE</code></p> <p>numRecords: <code>1</code></p> <p>minSampleRate: <code>1,000,000,000</code></p> <p>refPosition: <code>50.0</code></p> <p>minNumPts: <code>1,000</code></p>

- Configure an edge trigger using the niScope Configure Trigger (poly) VI. Select the Analog Edge Ref Trigger instance of the VI.

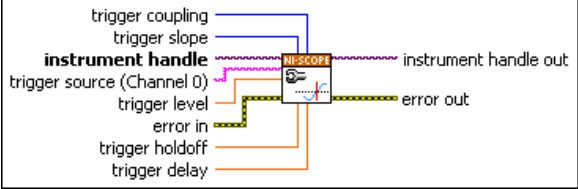
LabVIEW VI	C/C++ Function Call
	<p>Call <code>niScope_Configure TriggerEdge</code> with the following parameters:</p> <p>vi: The instrument handle from <code>niScope_init</code></p> <p>triggerCoupling: <code>NISCOPE_VAL_DC</code></p> <p>slope: The <i>Trigger Slope</i> value listed in Table 16 for the current iteration</p> <p>triggerSource: The <i>Trigger Source</i> value listed in Table 16 for the current iteration</p> <p>level: The <i>Measured Trigger Offset</i> value from step 12 in the Trigger Accuracy section for the current <i>Trigger Slope</i> and <i>Trigger Source</i> listed in Table 16</p> <p>holdoff: 0</p> <p>delay: 0</p>

- Commit all the parameter settings to hardware using the niScope Commit VI.

LabVIEW VI	C/C++ Function Call
	<p>Call <code>niScope_Commit</code> with the following parameter:</p> <p>vi: The instrument handle from <code>niScope_init</code></p>

- Connect the scope calibrator to the digitizer input as follows for the current *Trigger Source* value from Table 16:
 - Channel 0 and Channel 1—Connect the scope calibrator directly to the digitizer input channel as specified by the *Trigger Source* value from Table 16 for the current iteration.
 - External Trigger—Connect the scope calibrator to the external trigger channel (TRIG).
- Configure the scope calibrator to output the signal listed under the *Calibration Test Limits* or the *Published Specifications* in Table 16.

9. Wait 2,500 ms for the impedance matching and frequency of the calibrator to settle.
10. Initiate a waveform acquisition using the niScope Initiate Acquisition VI.

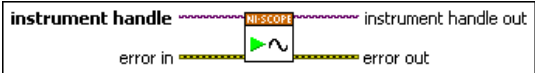
LabVIEW VI	C/C++ Function Call
	<p>Call <code>niScope_InitiateAcquisition</code> with the following parameter:</p> <p>vi: The instrument handle from <code>niScope_init</code></p>

11. Fetch a waveform from the digitizer using the niScope Fetch (poly) VI. Select the Cluster instance of the VI.

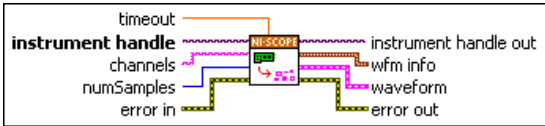
LabVIEW VI	C/C++ Function Call
	<p>Call <code>niScope_Fetch</code> with the following parameter:</p> <p>vi: The instrument handle from <code>niScope_init</code></p> <p>timeout: 2.0</p> <p>channelList: The <i>channelList</i> value from Table 16 for the current iteration.</p> <p>numSamples: -1</p>

If the digitizer does not time out, the digitizer has passed this portion of the verification. If the digitizer times out, you must call niScope Abort VI (`niScope_Abort` function) to end the acquisition.

12. Repeat steps 2 through 11 for each iteration in Table 16.
13. End the session using the niScope Close VI.

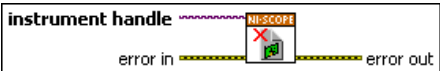
LabVIEW VI	C/C++ Function Call
	<p>Call <code>niScope_close</code> with the following parameters:</p> <p>vi: The instrument handle from <code>niScope_init</code></p>

You have finished verifying the trigger sensitivity for the NI 5152/5153/5154.

Table 16. NI 5152/5153/5154 Trigger Sensitivity Inputs

Iteration	Channel List	Trigger Source	Trigger Slope	Calibrator Signal	
				Calibration Test Limits	Published Specifications
1	0	0	NISCOPE_ VAL_POSITIVE	98.5 mV _{pp} 300 MHz Sinewave	100 mV _{pp} 300 MHz Sinewave
2	0	0	NISCOPE_ VAL_NEGATIVE	98.5 mV _{pp} 300 MHz Sinewave	100 mV _{pp} 300 MHz Sinewave
3	1	1	NISCOPE_ VAL_POSITIVE	98.5 mV _{pp} 300 MHz Sinewave	100 mV _{pp} 300 MHz Sinewave
4	1	1	NISCOPE_ VAL_NEGATIVE	98.5 mV _{pp} 300 MHz Sinewave	100 mV _{pp} 300 MHz Sinewave
5	1	NISCOPE_ VAL_EXTERNAL	NISCOPE_ VAL_POSITIVE	985 mV _{pp} 300 MHz Sinewave	1.0 V _{pp} 300 MHz Sinewave
6	1	NISCOPE_ VAL_EXTERNAL	NISCOPE_ VAL_NEGATIVE	985 mV _{pp} 300 MHz Sinewave	1.0 V _{pp} 300 MHz Sinewave

Adjustment

If the NI 5152/5153/5154 successfully passed each of the verification procedures within the calibration test limits, then an adjustment is recommended but not required to warrant the published specifications for the next two years. If the digitizer was not within the calibration test limits for each of the verification procedures, you can perform the adjustment procedure to improve the accuracy of the digitizer. Refer to [Appendix A: Calibration Options](#) to determine which procedures to perform.

An adjustment is required only once every two years. Following the adjustment procedure automatically updates the calibration date and temperature in the EEPROM of the digitizer.



Note If the digitizer passed the entire verification procedure within the calibration test limits and you do not want to perform an adjustment, you can update the calibration date and onboard calibration temperature without making any adjustments by calling *only* niScope Cal Start and niScope Cal End VIs.

Complete the following steps to externally adjust the NI 5152/5153/5154.

1. Obtain a calibration session handle using the niScope Cal Start VI.

LabVIEW VI	C/C++ Function Call
 <p>The diagram shows a LabVIEW VI named 'niScope Cal Start'. It has three input terminals on the left: 'resource name' (purple), 'password' (magenta), and 'error in' (yellow). It has two output terminals on the right: 'instrument handle' (purple) and 'error out' (yellow). The 'Start' control is connected to the 'niSCOPE' function block.</p>	<p>Call <code>niScope_CalStart</code> with the following parameters:</p> <p>resourceName: The device number assigned by MAX password: "NI "</p>

2. Connect the calibrator test head directly to the digitizer input channel 0.
3. Configure the calibrator to output the voltage listed under *Input (V)* in Table 17 (NI 5152), or Table 18 (NI 5153/5154) for the current iteration. Configure the load impedance of the calibrator to 1 M Ω (NI 5152), or 50 Ω (NI 5153/5154).
4. Wait 2,500 ms for the impedance matching of the calibrator to settle.
5. Adjust the vertical range using the niScope Cal Adjust Range VI.

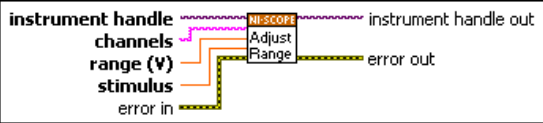
LabVIEW VI	C/C++ Function Call
 <p>The diagram shows a LabVIEW VI named 'niScope Cal Adjust Range'. It has four input terminals on the left: 'instrument handle' (purple), 'channels' (magenta), 'range (V)' (orange), and 'stimulus' (red). It has two output terminals on the right: 'instrument handle out' (purple) and 'error out' (yellow). The 'Adjust Range' control is connected to the 'niSCOPE' function block.</p>	<p>Call <code>niScope_CalAdjustRange</code> with the following parameters:</p> <p>vi: The instrument handle from <code>niScope_CalStart</code> channelName: "0" range: The <i>Range</i> value listed in Table 17 (NI 5152), Table 18 (NI 5153/5154) for the current iteration stimulus: The <i>Input (V)</i> value listed in Table 17 (NI 5152), Table 18 (NI 5153/5154) for the current iteration</p>

6. Repeat steps 3 through 5 for each iteration in Table 17 (NI 5152) or Table 18 (NI 5153/5154).
7. Move the scope calibrator test head to the digitizer input channel 1 and repeat steps 3 through 6, changing the value of the **channelName** parameter from "0" to "1".
8. Move the scope calibrator test head to the external trigger channel input on the digitizer.

9. Configure the calibrator to output the voltage listed under *Input (V)* in Table 19 (NI 5152), or Table 20 (NI 5153/5154) for the current iteration. Configure the load impedance of the calibrator to 1 MΩ.
10. Wait 2,500 ms for the impedance matching of the calibrator to settle.
11. Adjust the vertical range using the niScope Cal Adjust Range VI.

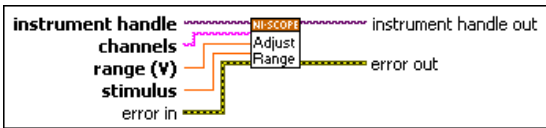
LabVIEW VI	C/C++ Function Call
	<p>Call <code>niScope_CalAdjustRange</code> with the following parameters:</p> <p>vi: The instrument handle from <code>niScope_CalStart</code></p> <p>channelName: "NISCOPE_VAL_EXTERNAL"</p> <p>range: The <i>Range</i> value listed in Table 19 (NI 5152), Table 20 (NI 5153/5154) for the current iteration</p> <p>stimulus: The <i>Input (V)</i> value listed in Table 19 (NI 5152), Table 20 (NI 5153/5154) for the current iteration</p>

12. Repeat steps 9 through 11 for each iteration in Table 19 (NI 5152), or Table 20 (NI 5153/5154).
13. Using a BNC cable, connect REF FREQUENCY OUTPUT on the back of the calibrator to the channel 0 input of the digitizer. Make sure the output of the reference frequency is enabled and set to 10 MHz. If you are not using a Fluke 9500B/Wavetek 9500 calibrator, connect a precise 10 MHz, 1 V_{pk-pk} sine or square wave source to the channel 0 input.
14. Calibrate the sample rate of the digitizer using the niScope Cal Adjust VCXO VI.

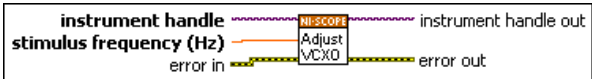
LabVIEW VI	C/C++ Function Call
	<p>Call <code>niScope_CalAdjustVCXO</code> with the following parameters:</p> <p>vi: The instrument handle from <code>niScope_CalStart</code></p> <p>stimulusFreq: 10,000,000</p>



Note The 10 MHz stimulus is automatically taken from channel 0.

15. Disconnect or disable all inputs to the digitizer.

16. Self-calibrate the digitizer using niScope Cal Self Calibrate VI.

LabVIEW VI	C/C++ Function Call
	<p>Call <code>niScope_CalSelfCalibrate</code> with the following parameters:</p> <p>vi: The instrument handle from <code>niScope_CalStart</code> channelList: <code>VI_NULL</code> option: <code>VI_NULL</code></p>

17. End the calibration session by calling the niScope Cal End VI.

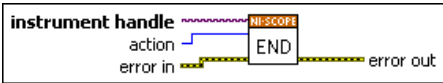
LabVIEW VI	C/C++ Function Call
	<p>Call <code>niScope_CalEnd</code> with the following parameters:</p> <p>sessionHandle: The instrument handle from <code>niScope_CalStart</code> action: <code>NISCOPE_VAL_ACTION_STORE</code> to save the results of the calibration</p>

You have finished adjusting the NI 5152/5153/5154. Repeat the [Verification](#) section to reverify the performance of the digitizer after adjustments.

Table 17. NI 5152 Input Parameters for Input Channel External Adjustment

Iteration	Range (Vpp)	Input (V)
1	10	4.5
2	4	1.8
3	2	0.9
4	1	0.45
5	0.4	0.18
6	0.2	0.09
7	0.1	0.045
8	10	-4.5
9	4	-1.8
10	2	-0.9

Table 17. NI 5152 Input Parameters for Input Channel External Adjustment (Continued)

Iteration	Range (Vpp)	Input (V)
11	1	-0.45
12	0.4	-0.18
13	0.2	-0.09
14	0.1	-0.045

Table 18. NI 5153/5154 Input Parameters for Input Channel External Adjustment

Iteration	Range (Vpp)	Input (V)
1	5	0.45
2	2	0.45
3	1	0.45
4	0.5	0.18
5	0.2	0.09
6	0.1	0.045
7	5	-0.45
8	2	-0.45
9	1	-0.45
10	0.5	-0.18
11	0.2	-0.09
12	0.1	-0.045

Table 19. NI 5152 Input Parameters for External Trigger Channel External Adjustment

Iteration	Range (Vpp)	Input (V)
1	10	4.5
2	10	-4.5

Table 20. NI 5153/5154 Input Parameters for External Trigger Channel External Adjustment

Iteration	Range (Vpp)	Input (V)
1	10	4.5
2	10	0

Appendix A: Calibration Options

External calibration involves verification and if necessary, adjustment and reverification. Adjustment is the process of measuring and compensating for device performance to improve the measurement accuracy. Performing an adjustment updates the calibration date, effectively resetting the calibration interval. The device is warranted to meet or exceed its published specifications for the duration of the calibration interval. Verification is the process of testing the device to ensure that the measurement accuracy is within certain specifications. Verification can be used to ensure that the adjustment process was successful or to determine if the adjustment process needs to be performed at all.

This document provides two sets of test limits for most verification stages—the *calibration test limits* and the *published specifications*. The calibration test limits are more restrictive than the published specifications. If all of the measurement errors determined during verification fall within the calibration test limits, the device is warranted to meet or exceed its published specifications for a full calibration interval (two years). For this reason, you must verify against the calibration test limits when performing verification after adjustment. If all of the measurement errors determined during verification fall within the published specifications, but not within the calibration test limits, the device is meeting its published specifications. However, the device will not necessarily remain within these specifications for an additional two years. The device will meet published specifications for the remainder of the current calibration interval. In this case, you can perform an adjustment if you want to further improve the measurement accuracy or reset the calibration interval. If some measurement errors determined during verification do not fall within the published specifications, you must perform an adjustment to restore the device operation to its published specifications.

The *Complete Calibration* section describes the recommended calibration procedure. The *Optional Calibration* section describes alternative procedures that allow you to skip adjustment if the device already meets its calibration test limits or published specifications.

Complete Calibration

Performing a complete calibration is the recommended way to warrant that the NI 5152/5153/5154 will meet or exceed its published specifications for a two-year calibration interval. At the end of the complete calibration procedure, you verify that the measurement error falls within the calibration test limits. Figure 1 shows the programming flow for complete calibration.

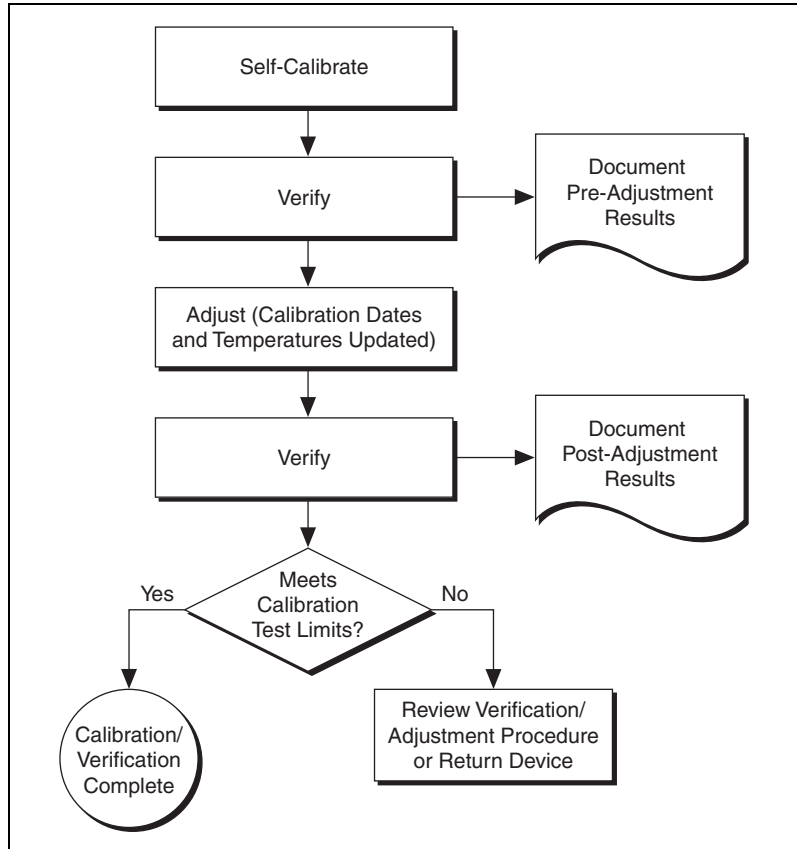

Figure 1. Complete Calibration Programming Flow

Optional Calibration

You can choose to skip the adjustment steps of the calibration procedure if the measurement error is within the calibration test limits or the published specifications during the first verification. If all of the measurement errors determined during the first verification fall within the calibration test limits, the device is warranted to meet or exceed its published specifications for a full calibration interval. In this case, you can update the calibration date, effectively resetting the calibration interval, without actually performing an adjustment. Refer to the [Adjustment](#) section for more information.

If all of the measurement errors determined during the first verification fall within the published specifications, but not within the calibration test limits, adjustment is also optional. However, you cannot update the calibration date because the device will not necessarily operate within the published specifications for an additional two years.



Note Regardless of the results of the first verification, if you choose to perform an adjustment, you must verify that the measurement error falls within the calibration test limits at the end of the calibration procedure.

Figure 2 shows the programming flow for the optional calibration.

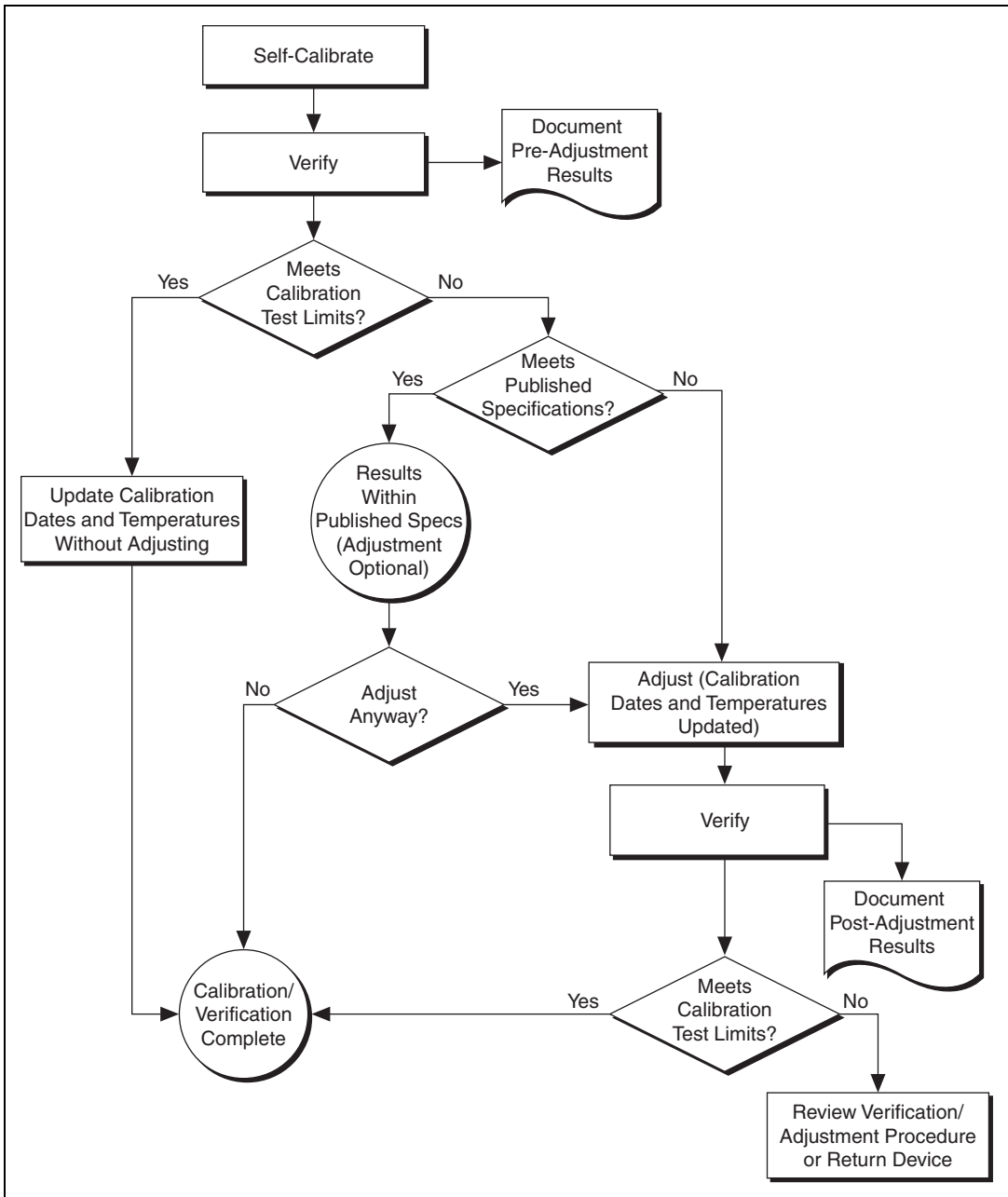

Figure 2. Optional Calibration Programming Flow

Appendix B: Calibration Utilities

NI-SCOPE supports several calibration utilities you can use to retrieve information about adjustments performed on the NI 5152/5153/5154, change the external calibration password, and store small amounts of information in the onboard EEPROM. Although you can retrieve some data using MAX, you can retrieve all the data programmatically using NI-SCOPE functions.

MAX

To retrieve data using MAX, complete the following steps:

1. Select the device from which you want to retrieve information from **My System»Devices and Interfaces»NI-DAQmx Devices**.
2. Select the **Calibration** tab in the lower right corner.

You should see information about the last date and temperature for both external and self-calibration.

NI-SCOPE

NI-SCOPE provides a full complement of calibration utility functions and VIs. Refer to the *NI High-Speed Digitizers Help* for the complete function reference and VI reference. The utility functions include:

- niScope Cal Change Password VI (niScope_CalChangePassword)
- niScope Cal Fetch Count VI (niScope_CalFetchCount)
- niScope Cal Fetch Date VI (niScope_CalFetchDate)
- niScope Cal Fetch Misc Info VI (niScope_CalFetchMiscInfo)
- niScope Cal Fetch Temperature VI (niScope_CalFetchTemperature)
- niScope Cal Store Misc Info VI (niScope_CalStoreMiscInfo)

Where to Go for Support

The National Instruments Web site is your complete resource for technical support. At ni.com/support you have access to everything from troubleshooting and application development self-help resources to email and phone assistance from NI Application Engineers.

A Declaration of Conformity (DoC) is our claim of compliance with the Council of the European Communities using the manufacturer's declaration of conformity. This system affords the user protection for electronic compatibility (EMC) and product safety. You can obtain the DoC for your product by visiting ni.com/certification. If your product supports calibration, you can obtain the calibration certificate for your product at ni.com/calibration.

National Instruments corporate headquarters is located at 11500 North Mopac Expressway, Austin, Texas, 78759-3504. National Instruments also has offices located around the world to help address your support needs. For telephone support in the United States, create your service request at ni.com/support and follow the calling instructions or dial 512 795 8248. For telephone support outside the United States, contact your local branch office:

Australia 1800 300 800, Austria 43 662 457990-0,
Belgium 32 (0) 2 757 0020, Brazil 55 11 3262 3599,
Canada 800 433 3488, China 86 21 5050 9800,
Czech Republic 420 224 235 774, Denmark 45 45 76 26 00,
Finland 358 (0) 9 725 72511, France 01 57 66 24 24,
Germany 49 89 7413130, India 91 80 41190000, Israel 972 3 6393737,
Italy 39 02 41309277, Japan 0120-527196, Korea 82 02 3451 3400,
Lebanon 961 (0) 1 33 28 28, Malaysia 1800 887710,
Mexico 01 800 010 0793, Netherlands 31 (0) 348 433 466,
New Zealand 0800 553 322, Norway 47 (0) 66 90 76 60,
Poland 48 22 328 90 10, Portugal 351 210 311 210,
Russia 7 495 783 6851, Singapore 1800 226 5886,
Slovenia 386 3 425 42 00, South Africa 27 0 11 805 8197,
Spain 34 91 640 0085, Sweden 46 (0) 8 587 895 00,
Switzerland 41 56 2005151, Taiwan 886 02 2377 2222,
Thailand 662 278 6777, Turkey 90 212 279 3031,
United Kingdom 44 (0) 1635 523545

National Instruments, NI, ni.com, and LabVIEW are trademarks of National Instruments Corporation. Refer to the *Terms of Use* section on ni.com/legal for more information about National Instruments trademarks. Other product and company names mentioned herein are trademarks or trade names of their respective companies. For patents covering National Instruments products/technology, refer to the appropriate location: **Help»Patents** in your software, the `patents.txt` file on your media, or the *National Instruments Patent Notice* at ni.com/patents.