

CALIBRATION PROCEDURE

Isolated M/S Series

This document contains instructions for calibrating National Instruments isolated M/S Series data acquisition (DAQ) devices, which include the NI 6154, NI 6230, NI 6232, NI 6233, NI 6236, NI 6238, and NI 6239.

This document does not discuss programming techniques or compiler configuration. The NI-DAQmx driver contains online help files that provide compiler-specific instructions and detailed function explanations. You can add these help files when you install NI-DAQmx on the calibration computer.

Contents

Conventions	2
Software	2
Documentation	3
Calibration Interval	3
Password	3
Test Equipment	3
Test Conditions	5
Calibration Procedure	5
Initial Setup	6
Self-Calibration	6
Checking Device Temperature Changes	7
Verification Procedure	8
Analog Input Verification	8
Analog Output Verification	13
Counter Verification	17
Adjustment Procedure	20
Test Limits	23
Isolated M Series Test Limits	24
NI 6230 Test Limits	24
NI 6232/6233 Test Limits	26
NI 6236 Test Limits	28
NI 6238/6239 Test Limits	29
Isolated S Series Test Limits	30
NI 6154 Test Limits	30

Conventions

The following conventions appear in this manual:

- <> Angle brackets that contain numbers separated by an ellipsis represent a range of values associated with a bit or signal name—for example, AO <3..0>.
- » The » symbol leads you through nested menu items and dialog box options to a final action. The sequence **File»Page Setup»Options** directs you to pull down the **File** menu, select the **Page Setup** item, and select **Options** from the last dialog box.
-  This icon denotes a note, which alerts you to important information.
- bold** Bold text denotes items that you must select or click in the software, such as menu items and dialog box options. Bold text also denotes parameter names.
- italic* Italic text denotes variables, emphasis, a cross-reference, or an introduction to a key concept. Italic text also denotes text that is a placeholder for a word or value that you must supply.
- monospace Text in this font denotes text or characters that you should enter from the keyboard, sections of code, programming examples, and syntax examples. This font is also used for the proper names of disk drives, paths, directories, programs, subprograms, subroutines, device names, functions, operations, variables, filenames, and extensions.
- monospace italic* Italic text in this font denotes text that is a placeholder for a word or value that you must supply.
- Platform** Text in this font denotes a specific platform and indicates that the text following it applies only to that platform.

Software

Calibration requires the latest NI-DAQmx driver. NI-DAQmx includes high-level function calls to simplify the task of writing software to calibrate devices. The driver supports many programming languages, including LabVIEW, LabWindows™/CVI™, C/C++, C#, and Visual Basic .NET.

Documentation

The following documents are your primary references for writing your calibration utility with NI-DAQmx:

- The *DAQ Getting Started Guide* for NI-DAQ 8.3 or later provides instructions for installing and configuring NI-DAQ devices.
- The *NI-DAQmx Help* includes information about creating applications that use the NI-DAQmx driver.
- The *NI-DAQmx C Reference Help* includes information about the functions in the driver.
- The following DAQ documentation provides information about your DAQ device:
 - The *NI 6230 User Manual* and *NI 6230 Specifications* for PCI/PXI-6230 devices
 - The *NI 6232/6233 User Manual* and *NI 6232/6233 Specifications* for PCI/PXI-6232 and PCI/PXI-6233 devices
 - The *NI 6236 User Manual* and *NI 6236 Specifications* for PCI/PXI-6236 devices
 - The *NI 6238/6239 User Manual* and *NI 6238/6239 Specifications* for PCI/PXI-6238 and PCI/PXI-6239 devices
 - The *S Series User Manual* and *NI 6154 Specifications* for PCI-6154 devices

Calibration Interval

Isolated M/S Series devices should be calibrated at regular intervals as defined by the measurement accuracy requirements of your application. National Instruments recommends that you routinely perform a complete calibration at least once every year. You can shorten this interval based on the accuracy demands of your application or requirements of your processes.

Password

The default password for password-protected operations is NI.

Test Equipment

National Instruments recommends that you use the instruments in Table 1 for calibrating an isolated M/S Series device.

Table 1. Recommended Calibration Equipment

Equipment	Recommended Model	Comments
Calibrator	Fluke 5700A	If this instrument is unavailable, use a voltage source that is at least 10 ppm accurate for 16-bit voltage input devices, or use a current source that is at least 100 ppm accurate for 16-bit current input devices.
DMM	NI 4070	If this instrument is unavailable, use a multiranging 6½-digit DMM with an accuracy of 40 ppm or better.
Counter	Agilent 53131A	If this instrument is unavailable, use a counter accurate to 0.01%.
PXI chassis	NI PXI-1042, NI PXI-1042Q	Use with PXI modules.
Power supply	NI 4110	(NI 6238/6239 Devices) For analog output verification, use any 10–30 VDC, 100 mA power supply. (NI 6232/6233/6238/6239 Devices) For counter verification, use any 5 VDC, 200 mA power supply.
Resistor	—	(NI 6238/6239 Devices) For analog output verification, use any 100 Ω resistor. (NI 6232/6233/6238/6239 Devices) For counter verification, use any 1 kΩ resistor.
Low thermal copper EMF plug-in cable	Fluke 5440A-7002	Do <i>not</i> use standard banana cables.
Shielded DAQ cable	NI DB37M-DB37F-EP	Use with NI 6154/6230/6236 devices.*
	NI SH37F-37M-1	Use with NI 6232/6233/6238/6239 devices.
DAQ accessory	NI CB-37F-LP	Low profile terminal block with 37 screw terminals.
	NI CB-37FH	Horizontal DIN-mountable terminal block with 37 screw terminals.
	NI CB-37FV	Vertical DIN-mountable terminal block with 37 screw terminals.
	NI CB-37F-HVD	37-pin DIN rail screw terminal block, UL Recognized derated to 30 V _{rms} , 42.4 V _{pk} , or 60 VDC.

* You can also use the NI SH37F-37M-1 cable with NI 6230/6236 devices.

Test Conditions

Follow these guidelines to optimize the connections and the environment during calibration:

- Keep connections to the device as short as possible. Long cables and wires can act as antennae, which could pick up extra noise that might affect measurements.
- Use shielded copper wire for all cable connections to the device. Use twisted-pair wire to eliminate noise and thermal offsets.
- Maintain the ambient temperature between 18–28 °C. The device temperature will be greater than the ambient temperature.
- Keep relative humidity below 80%.
- Allow a warm-up time of at least 15 minutes to ensure that the measurement circuitry is at a stable operating temperature.
- **(PXI Devices)** Ensure that the PXI chassis fan speed is set to HIGH, the fan filters are clean, and the empty PXI slots contain filler panels.

Calibration Procedure

The calibration process has six steps.

1. *Initial Setup*—Configure your device in NI-DAQmx.
2. *Self-Calibration*—Adjust the device to account for short-term environmental changes. No external signal is required.
3. *Checking Device Temperature Changes*—Verify that the current device temperature will not cause you to incorrectly calibrate your device.
4. *Verification Procedure*—Verify the existing operation of the device. This step allows you to confirm that the device was operating within its specified range prior to calibration.
5. *Adjustment Procedure*—Perform an external calibration that adjusts the device calibration constants with respect to a known voltage source.
6. *Reverification*—Perform another verification to ensure that the device is operating within its specifications after adjustment.

These steps are described in detail in the following sections. Although NI recommends that you verify all ranges, you can save time by checking only the ranges used in your application.

Initial Setup

Configure your isolated M/S Series device in Measurement & Automation Explorer (MAX) to communicate with NI-DAQmx.

The following procedure describes how to configure a device in MAX.

1. Install the NI-DAQmx driver software.
2. Power off the computer/chassis that will hold the device and install the device in an available slot.
3. Power on the computer and launch MAX.
4. Configure the device identifier and select **Self-Test** to ensure that the device is working properly.



Note When a device is configured with MAX, it is assigned a device identifier. Each function call uses this identifier to determine which DAQ device to calibrate.

Self-Calibration

Self-calibration should be performed after the device has warmed up for the recommended time period of 15 minutes. Call self-calibration before doing the first verification. This function measures the onboard reference voltage of the device and adjusts the self-calibration constants to account for any errors caused by short-term fluctuations in the environment. Disconnect all external signals when you self-calibrate a device.

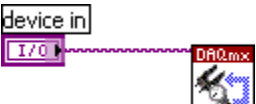
LabVIEW Block Diagram	NI-DAQmx Function Call
	Call DAQmxSelfCal with the following parameters: Device_Name[]: dev1

You also can initiate self-calibration using MAX, by completing the following steps.

1. Launch MAX.
2. Select **My System»Devices and Interfaces»NI-DAQmx Devices»your device**.
3. Initiate self-calibration using one of the following methods:
 - Click **Self-Calibrate** in the upper right corner of MAX.
 - Right-click the name of the device in the MAX configuration tree and select **Self-Calibrate** from the drop-down menu.

Checking Device Temperature Changes

Device temperature changes (greater than ± 10 °C since the previous external calibration or greater than ± 1 °C since the previous self-calibration) can cause you to incorrectly calibrate your device. After self-calibrating your device (as described in the [Self-Calibration](#) section), complete the following steps to compare the current device temperature to the temperatures measured during the last self-calibration and external calibration.

1. Read the current temperature measured by the device by using the DevTemp property node.

LabVIEW Block Diagram	NI-DAQmx Function Call
<p>The LabVIEW block diagram shows an 'ActiveDev' block with an 'I/O' icon on its left side. A dashed arrow points from the 'ActiveDev' block to a 'DAQmx Calibration Info' block. Inside the 'DAQmx Calibration Info' block, there is a sub-block labeled 'ActiveDev' and another labeled 'DevTemp'. An arrow points from the 'DevTemp' sub-block to a 'DBL' (Double) data type icon.</p>	<p>Call DAQmxGetCalDevTemp with the following parameter:</p> <p>deviceName: dev1</p>

2. Get the temperature of the device recorded during the last self-calibration by using the SelfCal.LastTemp property node.

LabVIEW Block Diagram	NI-DAQmx Function Call
<p>The LabVIEW block diagram shows an 'ActiveDev' block with an 'I/O' icon on its left side. A dashed arrow points from the 'ActiveDev' block to a 'DAQmx Calibration Info' block. Inside the 'DAQmx Calibration Info' block, there is a sub-block labeled 'ActiveDev' and another labeled 'SelfCal.LastTemp'. An arrow points from the 'SelfCal.LastTemp' sub-block to a 'DBL' (Double) data type icon.</p>	<p>Call DAQmxGetSelfCalLastTemp with the following parameter:</p> <p>deviceName: dev1</p>

If the difference between the current temperature and the temperature from the last self-calibration is greater than 1 °C, the limits in the calibration tables are not valid.

3. Get the temperature of the device recorded during the last external calibration by using the ExtCal.LastTemp property node.

LabVIEW Block Diagram	NI-DAQmx Function Call
<p>The LabVIEW block diagram shows an 'ActiveDev' block with an 'I/O' icon on its left side. A dashed arrow points from the 'ActiveDev' block to a 'DAQmx Calibration Info' block. Inside the 'DAQmx Calibration Info' block, there is a sub-block labeled 'ActiveDev' and another labeled 'ExtCal.LastTemp'. An arrow points from the 'ExtCal.LastTemp' sub-block to a 'DBL' (Double) data type icon.</p>	<p>Call DAQmxGetExtCalLastTemp with the following parameter:</p> <p>deviceName: dev1</p>

If the difference between the current temperature and the temperature from the last external calibration is greater than 10 °C, the limits in the calibration tables are not valid.



Note $\pm 10^{\circ}\text{C}$ is the maximum temperature change for most DAQ devices. To find the valid temperature drifts for your isolated M/S device, refer to the Absolute Accuracy table(s) in your DAQ device specifications document.



Note You also can read the current device temperature, the temperature during the last self-calibration, and the temperature during the last external calibration in MAX. Launch MAX, select **Select My System»Devices and Interfaces»NI-DAQmx Devices» your device**, then click the **Calibration** tab.

If the device temperature is outside the maximum range, you should choose one of the following options:

- Change the test limits to include the additional error due to temperature drift. Refer to your DAQ device specifications document for more information.
- Change the system so that the temperature will be closer to the temperature recorded during the last external calibration.

Verification Procedure

Verification determines how well the DAQ device is meeting its specifications. By performing this procedure, you can see how your device has operated over time. You can use this information to help determine the appropriate calibration interval for your application.

The verification procedure is divided into the major functions of the device. Throughout the verification process, use the appropriate table in the [Test Limits](#) section to determine if your device needs to be adjusted.

Analog Input Verification

Since isolated M/S Series devices have many different ranges, you must verify measurements for each available range. Isolated M/S Series devices have two analog input types—voltage and current. Table 2 lists the isolated M/S Series device analog input types.

Table 2. Isolated M/S Series Device Analog Input Types

Device	Analog Input Type
NI 6154, NI 6230, NI 6232, NI 6233	Voltage Input
NI 6236, NI 6238, NI 6239	Current Input

(NI 6154 Devices Only) NI 6154 devices have one analog-to-digital converter (ADC) per analog input channel, so you must perform verification on each channel.

(NI 6230/6232/6233 Devices Only) NI 6230/6232/6233 devices have one ADC, so you only need to perform verification on one analog input channel.

(NI 6236/6238/6239 Devices Only) You must perform verification on all analog input channels of the current input devices because each analog input channel has its own sense resistor.

Complete the following steps to verify analog input performance.

1. Refer to Table 3 to determine connections between the device and the calibrator.



Note (NI 6154 Devices Only) If your calibrator has a guard connection, leave it unconnected.



Note (NI 623x Devices Only) If your calibrator has a guard connection, connect that terminal to AI GND. If your calibrator does not have a guard connection, connect the negative output to AI GND. For more information, refer to your DAQ device user manual.

Table 3. Analog Input Connections

Device	Analog Input	Calibrator		
		Positive Output	Negative Output	Guard Connection
NI 6154*	AI 0	Pin 20	Pin 1	—
	AI 1	Pin 3	Pin 21	
	AI 2	Pin 23	Pin 4	
	AI 3	Pin 6	Pin 24	
NI 6230*	AI 0	Pin 20	Pin 1	AI GND (pin 2)
NI 6232*, NI 6233*	AI 0	Pin 1	Pin 20	AI GND (pin 3)
NI 6236†	AI 0+, AI 0–	Pin 20	Pin 1	AI GND (pin 2)
	AI 1+, AI 1–	Pin 3	Pin 21	
	AI 2+, AI 2–	Pin 23	Pin 4	
	AI 3+, AI 3–	Pin 6	Pin 24	

Table 3. Analog Input Connections (Continued)

Device	Analog Input	Calibrator		
		Positive Output	Negative Output	Guard Connection
NI 6238 [†] , NI 6239 [†]	AI 0+, AI 0-	Pin 1	Pin 20	AI GND (pin 3)
	AI 1+, AI 1-	Pin 21	Pin 2	
	AI 2+, AI 2-	Pin 22	Pin 4	
	AI 3+, AI 3-	Pin 5	Pin 23	
	AI 4+, AI 4-	Pin 6	Pin 25	
	AI 5+, AI 5-	Pin 26	Pin 7	
	AI 6+, AI 6-	Pin 27	Pin 9	
	AI 7+, AI 7-	Pin 28	Pin 10	
<p>* NI 6154/6230/6232/6233 devices connect to calibrator positive and negative voltage outputs. [†] NI 6236/6238/6239 devices connect to calibrator positive and negative current outputs.</p>				

- Choose the table from the *Test Limits* section that corresponds to the device you are verifying. This table shows all acceptable settings for the device type. NI recommends that you verify all ranges, although you may want to save time by checking only the ranges used in your application.
- Create a task using `DAQmxCreateTask`.

LabVIEW Block Diagram	NI-DAQmx Function Call
LabVIEW does not require this step.	<p>Call <code>DAQmxCreateTask</code> with the following parameters:</p> <p>taskName: <code>AIVerificationTask</code> taskHandle: <code>&taskHandle</code></p>

- (NI 6154/6230/6232/6233 Devices Only)** Add a voltage channel to the task using the `DAQmx Create Virtual Channel VI` and configure the channel. Use the appropriate analog input table in the *Test Limits* section to determine the minimum and maximum values for the input range being verified on your device.

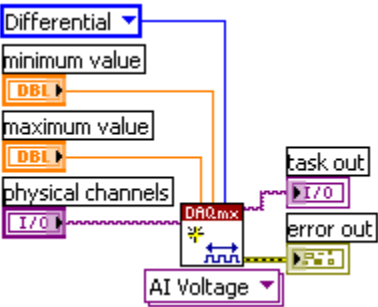

Note Throughout the procedure, refer to the NI-DAQmx function call parameters for the LabVIEW input values.

LabVIEW Block Diagram	NI-DAQmx Function Call
 <p>The diagram shows a DAQmx Create AI Voltage Channel block. It has several input controls: a 'Differential' dropdown menu, 'minimum value' and 'maximum value' numeric inputs (each with a DB1 control), a 'physical channels' dropdown menu, and an 'I/O' dropdown menu. The block is connected to a 'task out' control, an 'error out' control, and an 'AI Voltage' dropdown menu.</p>	<p>Call DAQmxCreateAIVoltageChan with the following parameters:</p> <p>taskHandle: taskHandle physicalChannel: dev1/ai0 nameToAssignToChannel: myVoltageChannel terminalConfig: DAQmx_Val_InputTermCfg_Diff minVal: -10.0 maxVal: 10.0 units: DAQmx_Val_Volts customScaleName: NULL</p>

- (NI 6236/6238/6239 Devices Only) Add a current channel to the task using the DAQmx Create Virtual Channel VI and configure the channel. Use the appropriate analog input table in the *Test Limits* section to determine the minimum and maximum values for your device.

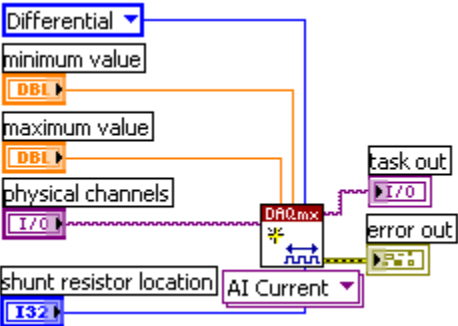
LabVIEW Block Diagram	NI-DAQmx Function Call
 <p>The diagram shows a DAQmx Create AI Current Channel block. It has several input controls: a 'Differential' dropdown menu, 'minimum value' and 'maximum value' numeric inputs (each with a DB1 control), a 'physical channels' dropdown menu, an 'I/O' dropdown menu, and a 'shunt resistor location' dropdown menu (with an I32 control). The block is connected to a 'task out' control, an 'error out' control, and an 'AI Current' dropdown menu.</p>	<p>Call DAQmxCreateAICurrentChan with the following parameters:</p> <p>taskHandle: taskHandle physicalChannel: dev1/ai0 nameToAssignToChannel: myCurrentChannel terminalConfig: DAQmx_Val_InputTermCfg_Diff minVal: -.02 maxVal: .02 units: DAQmx_Val_Amps customScaleName: NULL ShuntResistorLocation: Internal</p>

6. Configure timing for the acquisition using the DAQmx Timing VI.

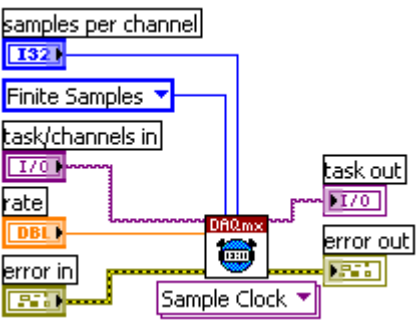
LabVIEW Block Diagram	NI-DAQmx Function Call
	<p>Call DAQmxCfgSampClkTiming with the following parameters:</p> <p>taskHandle: taskHandle source: NULL rate: 100000.0 activeEdge: DAQmx_Val_Rising sampleMode: DAQmx_Val_FiniteSamps sampsPerChan: 10000</p>

7. Set the calibrator voltage or current to the test value indicated in the device table from the *Test Limits* section.
8. Ensure that the calibrator output is enabled.
9. Start the acquisition using the DAQmx Start Task VI.

LabVIEW Block Diagram	NI-DAQmx Function Call
	<p>Call DAQmxStartTask with the following parameter:</p> <p>taskHandle: taskHandle</p>

10. Acquire 10,000 points of voltage or current data, depending on which device you are verifying, using the DAQmx Read VI.

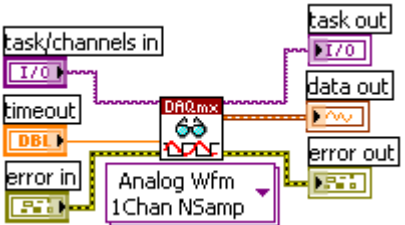
LabVIEW Block Diagram	NI-DAQmx Function Call
	<p>Call DAQmxReadAnalogF64 with the following parameters:</p> <p>taskHandle: taskHandle numSampsPerChan: -1 timeout: 10.0 fillMode: DAQmx_Val_GroupByChannel readArray: data arraySizeInSamples: 10000 sampsPerChanRead: &read reserved: NULL</p>

11. Average the acquired values. Compare the resulting average to the upper and lower limits listed in the table. If the result is between these values, the device passes the test.
12. Clear the acquisition using the DAQmx Clear Task VI.

LabVIEW Block Diagram	NI-DAQmx Function Call
	<p>Call DAQmxClearTask with the following parameter:</p> <p>taskHandle: taskHandle</p>

13. Repeat steps 3 through 12 until all values listed in the table have been verified.
14. **(NI 6154/6236/6238/6239 Devices Only)** Disconnect the calibrator from AI 0 and reconnect it to AI 1, making the connections in Table 3.
Repeat steps 3 through 13 for all AI channels on the device.
15. Disconnect the calibrator from the device.

You have finished verifying the analog input levels on your device.

Analog Output Verification

This procedure verifies the performance of all analog output channels. Isolated M/S Series devices have two analog output types—voltage and current. Table 4 lists the isolated M/S Series device analog output type and channel number.

Table 4. Isolated M/S Series Device Analog Output Type and Channel Number

Device	Analog Output Type	Analog Output Channels
NI 6154, NI 6230, NI 6236	Voltage Output	Four, AO <0..3>
NI 6232, NI 6233	Voltage Output	Two, AO <0..1>
NI 6238, NI 6239	Current Output	Two, AO <0..1>

Complete the following steps to verify analog output measurements.

1. Connect the power supply (if needed) and resistor (if needed), and connect the DMM to AO 0, as shown in Table 5. Make sure that the connection matches the type of output of your device.

Table 5. Analog Output Connections

Device	Analog Output	DMM		100 Ω Resistor	Power Supply	
		Positive Input	Negative Input		Positive Input	Negative Input
NI 6154*	AO 0	Pin 26	Pin 7	N/A	N/A	N/A
	AO 1	Pin 9	Pin 27			
	AO 2	Pin 29	Pin 10			
	AO 3	Pin 12	Pin 30			
NI 6230*, NI 6236*	AO 0	Pin 26	Pin 27	N/A	N/A	N/A
	AO 1	Pin 9	Pin 27			
	AO 2	Pin 29	Pin 27			
	AO 3	Pin 12	Pin 27			
NI 6232*, NI 6233*	AO 0	Pin 30	Pin 31	N/A	N/A	N/A
	AO 1	Pin 12	Pin 31			
NI 6238†, NI 6239†	AO 0	Pin 30	Pin 31	Between pin 30 and DMM+	AO Power Supply (pin 29)	AO GND (pin 31)
	AO 1	Pin 12	Pin 31	Between pin 12 and DMM+		

* NI 6154/6230/6232/6233/6236 devices connect to DMM positive and negative voltage inputs.
† NI 6238/6239 devices connect to DMM positive and negative current inputs. Refer to Figure 1 for resistor location.

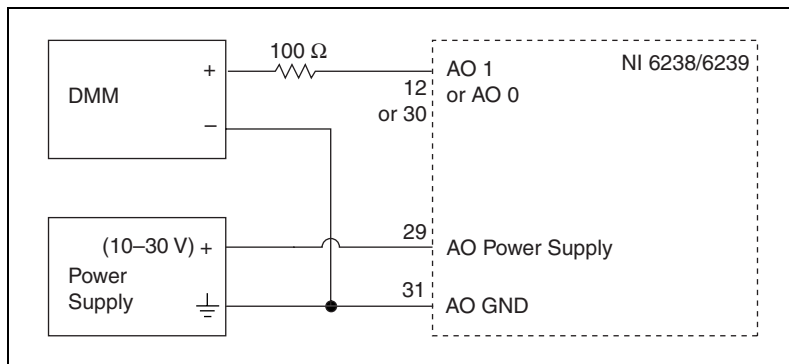

Figure 1. NI 6238/6239 Resistor Location

- Choose the table from the *Test Limits* section that corresponds to the device you are verifying. This table shows all acceptable settings for the device. NI recommends that you verify all ranges, although you may want to save time by verifying only the ranges used in your application.
- Create a task using DAQmxCreateTask.

LabVIEW Block Diagram	NI-DAQmx Function Call
LabVIEW does not require this step.	Call DAQmxCreateTask with the following parameters: taskName: <i>MyAOTask</i> taskHandle: <i>&taskHandle</i>

- (NI 6154/6230/6232/6233/6236 Devices Only) Add an AO voltage task using the DAQmx Create Virtual Channel VI and configure AO 0. Use the appropriate analog output table in the *Test Limits* section to determine the minimum and maximum values for your device.



Note Throughout the procedure, refer to the NI-DAQmx function call parameters for the LabVIEW input values.

LabVIEW Block Diagram	NI-DAQmx Function Call
	Call DAQmxCreateAOVoltageChan with the following parameters: taskHandle: <i>taskHandle</i> physicalChannel: <i>dev1/ao0</i> nameToAssignToChannel: <i>AOVoltageChannel</i> minVal: <i>-10.0</i> maxVal: <i>10.0</i> units: <i>DAQmx_Val_Volts</i> customScaleName: <i>NULL</i>

- (NI 6238/6239 Devices Only) Add an AO current task using the DAQmx Create Virtual Channel VI and configure AO 0. Use the appropriate analog output table in the *Test Limits* section to determine the minimum and maximum values for your device.

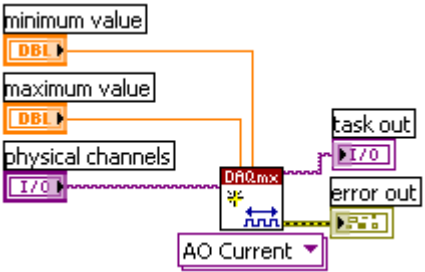
LabVIEW Block Diagram	NI-DAQmx Function Call
	<p>Call DAQmxCreateAOCurrentChan with the following parameters:</p> <p>taskHandle: taskHandle physicalChannel: dev1/ao0 nameToAssignToChannel: AOVoltageChannel minVal: 0 maxVal: .02 units: DAQmx_Val_Amps customScaleName: NULL</p>

6. Start the generation using the DAQmx Start Task VI.

LabVIEW Block Diagram	NI-DAQmx Function Call
	<p>Call DAQmxStartTask with the following parameters:</p> <p>taskHandle: taskHandle</p>

7. Write a voltage or current test point value from the table in the [Test Limits](#) section to the AO channel using the DAQmx Write VI.

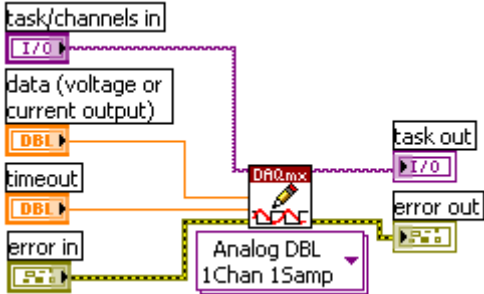
LabVIEW Block Diagram	NI-DAQmx Function Call
	<p>Call DAQmxWriteAnalogF64 with the following parameters:</p> <p>taskHandle: taskHandle numSampsPerChan: 1 autoStart: 1 timeout: 10.0 dataLayout: DAQmx_Val_GroupByChannel writeArray: &data sampsPerChanWritten: &samplesWritten reserved: NULL</p>

8. Compare the resulting value shown by the DMM to the upper and lower limits in the table in the [Test Limits](#) section. If the value is between these limits, the device passes the test.

- Clear the acquisition using the DAQmx Clear Task VI.

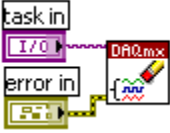
LabVIEW Block Diagram	NI-DAQmx Function Call
	<p>Call DAQmxClearTask with the following parameter:</p> <p>taskHandle: taskHandle</p>

- Repeat steps 3 through 9 until all values have been tested.
- Disconnect the DMM from AO 0, and reconnect it to AO 1, making the connections shown in Table 5.
- Repeat steps 3 through 11 for AO 1.

(NI 6154/6230/6236 Devices Only) Repeat steps 3 through 11 for both AO 2 and AO 3.
- Disconnect your DMM from the device.

You have finished verifying the analog output levels on your device.

Counter Verification

This procedure verifies the performance of the counter. Isolated M/S Series devices have only one timebase to verify, so only Counter 0 needs to be verified. It is not possible to adjust this timebase, so only verification can be performed. Complete the following steps to verify the counter.

- Connect the counter, power supply (if needed), and resistor (if needed) to your DAQ device as shown in Table 6.

Table 6. Counter Connections

Device	Counter		Power Supply		1 k Ω Resistor
	Positive Output	Negative Output	Positive Source	Negative Source	
NI 6154, NI 6230, NI 6236	CTR 0 OUT (pin 17)	D GND (pin 18)	N/A	N/A	N/A
NI 6232, NI 6238	CTR 0 OUT (pin 17)	P1.GND (pin 19)	P1.VCC (pin 35)	P1.GND (pin 19)	Between pin 17 and pin 19. Refer to Figure 2.
NI 6233, NI 6239	CTR 0 OUT (pin 17)	P1.GND (pin 35)	P1.VCC (pin 19)	P1.GND (pin 35)	Between pin 17 and pin 19. Refer to Figure 3.

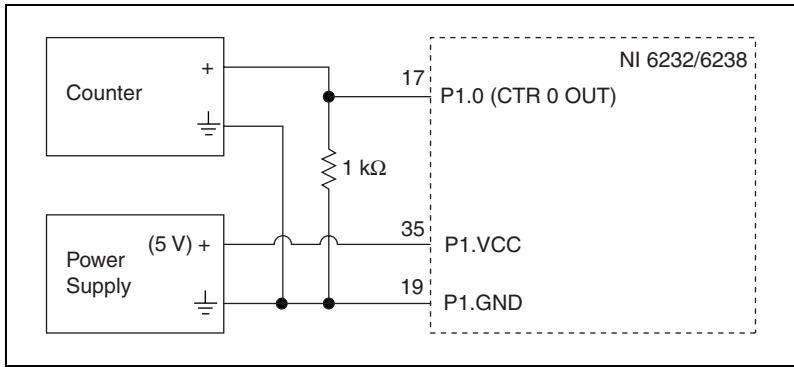

Figure 2. NI 6232/6238 Resistor Location

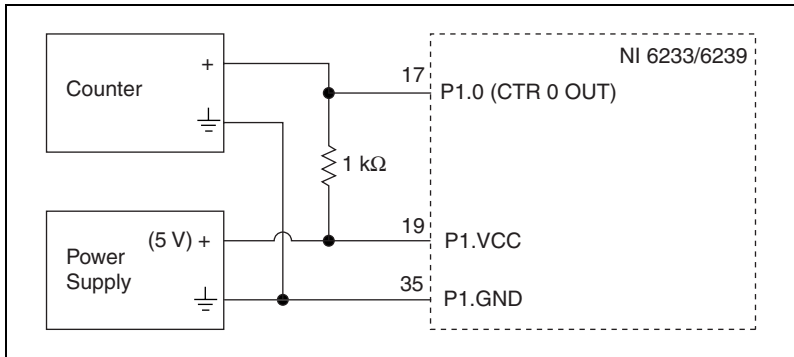

Figure 3. NI 6233/6239 Resistor Location

2. Create a task using `DAQmxCreateTask`.

LabVIEW Block Diagram	NI-DAQmx Function Call
LabVIEW does not require this step.	Call <code>DAQmxCreateTask</code> with the following parameters: taskName: <code>MyCounterOutputTask</code> taskHandle: <code>&taskHandle</code>

3. Add a counter output channel to the task using the DAQmx Create Virtual Channel VI and configure the channel.

(NI 6154/6230/6236 Devices Only) Use a frequency of 5 MHz.

(NI 6232/6233/6238/6239 Devices Only) Use a frequency of 10 kHz.

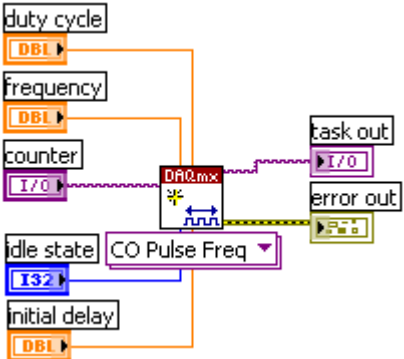

Note Throughout the procedure, refer to the NI-DAQmx function call parameters for the LabVIEW input values.

LabVIEW Block Diagram	NI-DAQmx Function Call
 <p>The diagram shows a DAQmx block with several inputs: 'duty cycle' (DBI), 'frequency' (DBI), 'counter' (I/O), 'idle state' (I32), and 'initial delay' (DBI). The DAQmx block is connected to a 'CO Pulse Freq' dropdown menu. The output of the DAQmx block is connected to a 'task out' (I/O) and an 'error out' (I/O) block.</p>	<p>Call DAQmxCreateCOPulseChanFreq with the following parameters:</p> <p>taskHandle: taskHandle counter: dev1/ctr0 nameToAssignToChannel: CounterOutputChannel units: DAQmx_Val_Hz idleState: DAQmx_Val_Low initialDelay: 0.0 freq: 5000000.0 or 10000.0 dutyCycle: .5</p>

- Configure the counter for continuous square wave generation using the DAQmx Timing VI.

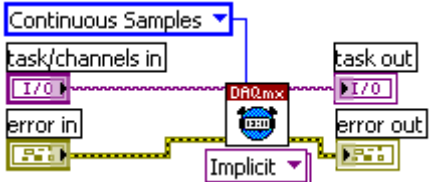
LabVIEW Block Diagram	NI-DAQmx Function Call
 <p>The diagram shows a DAQmx block with inputs: 'Continuous Samples' (dropdown), 'task/channels in' (I/O), and 'error in' (I/O). The DAQmx block is connected to an 'Implicit' dropdown menu. The output of the DAQmx block is connected to a 'task out' (I/O) and an 'error out' (I/O) block.</p>	<p>Call DAQmxCfgImplicitTiming with the following parameters:</p> <p>taskHandle: taskHandle sampleMode: DAQmx_Val_ContSamps sampsPerChan: 10000</p>

- Start the generation of a square wave using the DAQmx Start Task VI.

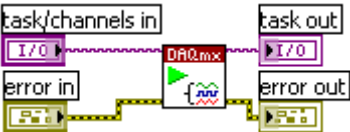
LabVIEW Block Diagram	NI-DAQmx Function Call
 <p>The diagram shows a DAQmx block with inputs: 'task/channels in' (I/O) and 'error in' (I/O). The DAQmx block is connected to a 'Start Task' button. The output of the DAQmx block is connected to a 'task out' (I/O) and an 'error out' (I/O) block.</p>	<p>Call DAQmxStartTask with the following parameter:</p> <p>taskHandle: taskHandle</p>

- Configure the counter to measure frequency and use a 1 MΩ impedance.
- Take the measurement of the square wave.
- Compare the value read by your counter to the test limits shown on the table in the *Test Limits* section. If the value falls between these limits, the device passes the test.

- Stop the generation using the DAQmx Stop Task VI.

LabVIEW Block Diagram	NI-DAQmx Function Call
	<p>Call DAQmxStopTask with the following parameter:</p> <p>taskHandle: taskHandle</p>

- Clear the generation using the DAQmx Clear Task VI.

LabVIEW Block Diagram	NI-DAQmx Function Call
	<p>Call DAQmxClearTask with the following parameter:</p> <p>taskHandle: taskHandle</p>

- Disconnect the counter from your device.
- (NI 6232/6233/6238/6239 Devices Only)** Disconnect the power supply.

You have verified the counter on your device.

Adjustment Procedure

Use the isolated M/S Series adjustment procedure to adjust the analog input and output calibration constants. At the end of each calibration procedure, these new constants are stored in the external calibration area of the EEPROM. These values are password-protected, which prevents the accidental access or modification of any calibration constants adjusted by the metrology laboratory. The default password is NI.

Complete the following steps to perform device adjustment with a calibrator.

- Connect the calibrator to the device using the connections listed in Table 7.



Note (NI 6154 Devices Only) If your calibrator has a guard connection, leave it unconnected.



Note (NI 623x Devices Only) If your calibrator has a guard connection, connect AI GND to the guard instead of the negative output. For more information, refer to your DAQ device user manual.

Table 7. Calibrator Connections

Device	Calibrator		
	Positive Output	Negative Output	Guard Connection
NI 6154*	Pin 20, pin 3, pin 23, and pin 6	Pin 1, pin 21, pin 4, and pin 24	—
NI 6230*	Pin 20	Pin 1	AI GND (pin 2)
NI 6232*, NI 6233*	Pin 1	Pin 20	AI GND (pin 3)
NI 6236†	Pin 20	Pin 8	AI GND (pin 2)
NI 6238†, NI 6239†	Pin 1	Pin 8	AI GND (pin 3)

* NI 6154/6230/6232/6233 devices connect to calibrator positive and negative voltage outputs.
† NI 6236/6238/6239 devices connect to calibrator positive and negative current outputs.

2. Set your calibrator to output 7.50 V.



Note (NI 6238/6239 Devices Only) Current input/output devices use a voltage for adjustment.

3. Open a calibration session on your device using the DAQmx Initialize External Calibration VI. The default password is NI.



Note Throughout the procedure, refer to the NI-DAQmx function call parameters for the LabVIEW input values.

LabVIEW Block Diagram	NI-DAQmx Function Call
	<p>Call DAQmxInitExtCal with the following parameters:</p> <p>deviceName: dev1 password: NI calHandle: &calHandle</p>

- Perform an external calibration adjustment.

(NI 6154 Devices Only) Use the DAQmx Adjust S-Series Calibration VI.

(NI 623x Devices Only) Use the DAQmx Adjust M-Series Calibration VI.

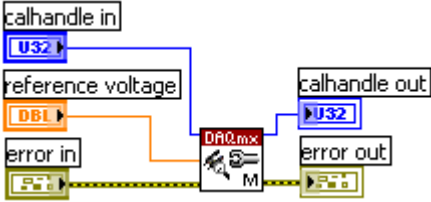
LabVIEW Block Diagram	NI-DAQmx Function Call
	<p>Call DAQmxMSeriesCalAdjust or DAQmxSSeriesCalAdjust with the following parameters:</p> <p>calHandle: calHandle referenceVoltage: 7.5</p>

- Save the adjustment to the EEPROM using the DAQmx Close External Calibration VI. This VI also saves the date, time, and temperature of the adjustment to the onboard memory.

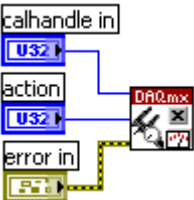

Note If an error occurs during the adjustment procedure, no constants are written to the EEPROM.

LabVIEW Block Diagram	NI-DAQmx Function Call
	<p>Call DAQmxCloseExtCal with the following parameters:</p> <p>calHandle: calHandle action: DAQmx_Val_Action_Commit</p>

- Disconnect the calibrator from the device.

The device is now calibrated with respect to your external source.

After calibrating the device, you may want to verify the analog input and output operation. To do this, repeat the [Verification Procedure](#) section.

Test Limits

The tables in this section list the specifications for isolated M/S Series devices. The specifications are divided into analog input, analog output, and counter/timer tables of values.

The following definitions describe how to use the information from the tables in this section:

- **Range**—Refers to the maximum allowable voltage range of an input or output signal.
- **Test Point**—The voltage value that is input or output for verification purposes. This value is broken down into two columns—*Location* and *Value*. Location refers to where the test value fits within the test range. Value refers to the voltage value to be verified and is in volts. Pos FS stands for positive full-scale and Neg FS stands for negative full-scale.
- **24-Hour Limits**—The values shown in the 24-hour tables are the valid specifications when a device has been calibrated with an external source. The *24-Hour Limits* column contains the *Upper Limits* and *Lower Limits* for the test point value. That is, when the device is within its 24-hour calibration interval, the test point value should fall between the upper and lower limit values. Upper and lower limits are expressed in volts or amps, depending on the device.



Note (NI 6154 Devices Only) NI 6154 devices only have 1-year limits specifications.

- **1-Year Limits**—The specifications that the devices should meet if it has been one year between calibrations. The *1-Year Limits* column contains the *Upper Limits* and *Lower Limits* for the test point value. That is, when the device is within its one year calibration interval, the test point value should fall between the upper and lower limit values. Upper and lower limits are expressed in volts or amps, depending on the device.

(NI 623x Devices Only) For M Series devices, calibration limits are valid only if the temperature of the device (as measured by the onboard temperature sensor) is within 10 °C of the last external calibration. You can find the data from the last external calibration in MAX.

- **Counters**—It is not possible to adjust the resolution of the counter/timers. Therefore, these values do not have a 1-year or 24-hour calibration period. However, the test point and upper and lower limits are provided for verification purposes.

Isolated M Series Test Limits

NI 6230 Test Limits

Tables 8 through 10 include values for the PCI-6230 and PXI-6230.

Table 8. NI 6230 Analog Input Values

Range (V)		Test Point		24-Hour Limits		1-Year Limits	
Minimum	Maximum	Location	Value (V)	Lower Limit (V)	Upper Limit (V)	Lower Limit (V)	Upper Limit (V)
-10	10	Pos FS	9.98	9.977798	9.982202	9.976900	9.983100
-10	10	0	0	-0.001603	0.001603	-0.001603	0.001603
-10	10	Neg FS	-9.98	-9.982202	-9.977798	-9.983100	-9.976900
-5	5	Pos FS	4.99	4.988834	4.991166	4.988385	4.991615
-5	5	0	0	-0.000817	0.000817	-0.000817	0.000817
-5	5	Neg FS	-4.99	-4.991166	-4.988834	-4.991615	-4.988385
-1	1	Pos FS	0.998	0.997731	0.998269	0.997641	0.998359
-1	1	0	0	-0.000189	0.000189	-0.000189	0.000189
-1	1	Neg FS	-0.998	-0.998269	-0.997731	-0.998359	-0.997641
-0.200	0.200	Pos FS	0.1996	0.199506	0.199694	0.199488	0.199712
-0.200	0.200	0	0	-0.000070	0.000070	-0.000070	0.000070
-0.200	0.200	Neg FS	-0.1996	-0.199694	-0.199506	-0.199712	-0.199488

Table 9. NI 6230 Analog Output Values

Range (V)		Test Point		24-Hour Limits		1-Year Limits	
Minimum	Maximum	Location	Value (V)	Lower Limit (V)	Upper Limit (V)	Lower Limit (V)	Upper Limit (V)
-10	10	Pos FS	9.98	9.977671	9.982329	9.976773	9.983227
-10	10	0	0	-0.001730	0.001730	-0.001730	0.001730
-10	10	Neg FS	-9.98	-9.982329	-9.977671	-9.983227	-9.976773

Table 10. NI 6230 Counter Values

Set Point (MHz)	Lower Limit (MHz)	Upper Limit (MHz)
5	4.99975	5.00025

NI 6232/6233 Test Limits

Tables 11 through 13 include values for the PCI-6232, PXI-6232, PCI-6233, and PXI-6233.

Table 11. NI 6232/6233 Analog Input Values

Range (V)		Test Point		24-Hour Limits		1-Year Limits	
Minimum	Maximum	Location	Value (V)	Lower Limit (V)	Upper Limit (V)	Lower Limit (V)	Upper Limit (V)
-10	10	Pos FS	9.980000	9.977798	9.982202	9.976900	9.983100
-10	10	0	0	-0.001603	0.001603	-0.001603	0.001603
-10	10	Neg FS	-9.98	-9.982202	-9.977798	-9.983100	-9.976900
-5	5	Pos FS	4.99	4.988834	4.991166	4.988385	4.991615
-5	5	0	0	-0.000817	0.000817	-0.000817	0.000817
-5	5	Neg FS	-4.99	-4.991166	-4.988834	-4.991615	-4.988385
-1	1	Pos FS	0.998	0.997731	0.998269	0.997641	0.998359
-1	1	0	0	-0.000189	0.000189	-0.000189	0.000189
-1	1	Neg FS	-0.998	-0.998269	-0.997731	-0.998359	-0.997641
-0.200	0.200	Pos FS	0.1996	0.199506	0.199694	0.199488	0.199712
-0.200	0.200	0	0	-0.000070	0.000070	-0.000070	0.000070
-0.200	0.200	Neg FS	-0.1996	-0.199694	-0.199506	-0.199712	-0.199488

Table 12. NI 6232/6233 Analog Output Values

Range (V)		Test Point		24-Hour Limits		1-Year Limits	
Minimum	Maximum	Location	Value (V)	Lower Limit (V)	Upper Limit (V)	Lower Limit (V)	Upper Limit (V)
-10	10	Pos FS	9.98	9.977671	9.982329	9.976773	9.983227
-10	10	0	0	-0.001730	0.001730	-0.001730	0.001730
-10	10	Neg FS	-9.98	-9.982329	-9.977671	-9.983227	-9.976773

Table 13. NI 6232/6233 Counter Values

Set Point (kHz)	Lower Limit (kHz)	Upper Limit (kHz)
10	9.9995	10.0005

NI 6236 Test Limits

Tables 14 through 16 include values for the PCI-6236 and PXI-6236.

Table 14. NI 6236 Analog Input Values

Range (A)		Test Point		24-Hour Limits		1-Year Limits	
Minimum	Maximum	Location	Value (A)	Lower Limit (A)	Upper Limit (A)	Lower Limit (A)	Upper Limit (A)
-0.02	0.02	Pos FS	0.01996	0.019942944	0.019977056	0.019941147	0.019978853
-0.02	0.02	0	0	-0.000005280	0.000005280	-0.000005280	0.000005280
-0.02	0.02	Neg FS	-0.01996	-0.019977056	-0.019942944	-0.019978853	-0.019941147

Table 15. NI 6236 Analog Output Values

Range (V)		Test Point		24-Hour Limits		1-Year Limits	
Minimum	Maximum	Location	Value (V)	Lower Limit (V)	Upper Limit (V)	Lower Limit (V)	Upper Limit (V)
-10	10	Pos FS	9.98	9.977671	9.982329	9.976773	9.983227
-10	10	0	0	-0.001730	0.001730	-0.001730	0.001730
-10	10	Neg FS	-9.98	-9.982329	-9.977671	-9.983227	-9.976773

Table 16. NI 6236 Counter Values

Set Point (MHz)	Lower Limit (MHz)	Upper Limit (MHz)
5	4.99975	5.00025

NI 6238/6239 Test Limits

Tables 17 through 19 include values for the PCI-6238, PXI-6238, PCI-6239, and PXI-6239.

Table 17. NI 6238/6239 Analog Input Values

Range (A)	Test Point		24-Hour Limits		1-Year Limits		
	Maximum	Location	Value (A)	Lower Limit (A)	Upper Limit (A)	Lower Limit (A)	Upper Limit (A)
-0.02	0.02	Pos FS	0.01996	0.019942944	0.019977056	0.019941147	0.019978853
-0.02	0.02	0	0	-0.000005280	0.000005280	-0.000005280	0.000005280
-0.02	0.02	Neg FS	-0.01996	-0.019977056	-0.019942944	-0.019978853	-0.019941147

Table 18. NI 6238/6239 Analog Output Values

Range (V)	Test Point		24-Hour Limits		1-Year Limits		
	Maximum	Location	Value (A)	Lower Limit (A)	Upper Limit (A)	Lower Limit (A)	Upper Limit (A)
0	0.02	Pos FS	0.0198	0.019755850	0.019844150	0.019754068	0.019845932
0	0.02	0	0	-0.000013460	0.000013460	-0.000013460	0.000013460

Table 19. NI 6238/6239 Counter Values

Set Point (kHz)	Lower Limit (kHz)	Upper Limit (kHz)
10	9.9995	10.0005

Isolated S Series Test Limits

NI 6154 Test Limits

Tables 20 through 22 include values for the PCL-6154.

Table 20. NI 6154 Analog Input Values

Range (V)		Test Point			1-Year Limits	
Minimum	Maximum	Location	Value (V)	Lower Limit (V)	Upper Limit (V)	
-10	10	Pos FS	9.98	9.974799	9.985201	
-10	10	0	0	-0.001648	0.001648	
-10	10	Neg FS	-9.98	-9.985201	-9.974799	
-5	5	Pos FS	4.99	4.986993	4.993007	
-5	5	0	0	-0.000981	0.000981	
-5	5	Neg FS	-4.99	-4.993007	-4.986993	
-2	2	Pos FS	1.99	1.988743	1.991257	
-2	2	0	0	-0.000461	0.000461	
-2	2	Neg FS	-1.99	-1.991257	-1.988743	
-1	1	Pos FS	0.998	0.997334	0.998666	
-1	1	0	0	-0.000267	0.000267	
-1	1	Neg FS	-0.998	-0.998666	-0.997334	

Table 21. NI 6154 Analog Output Values

Range (V)		Test Point			1-Year Limits	
Minimum	Maximum	Location	Value (V)	Lower Limit (V)	Upper Limit (V)	
-10	10	Pos FS	9.98	9.972017	9.987983	
-10	10	0	0	-0.004350	0.004350	
-10	10	Neg FS	-9.98	-9.987983	-9.972017	

Table 22. NI 6154 Counter Values

Set Point (MHz)	Lower Limit (MHz)	Upper Limit (MHz)
5	4.99975	5.00025

National Instruments, NI, ni.com, and LabVIEW are trademarks of National Instruments Corporation. Refer to the *Terms of Use* section on ni.com/legal for more information about National Instruments trademarks. Other product and company names mentioned herein are trademarks or trade names of their respective companies. For patents covering National Instruments products, refer to the appropriate location: **Help»Patents** in your software, the `patents.txt` file on your media, or ni.com/patents.