



MXI-Express x4 for PXI Express Series User Manual

MXI-Express for PXI Express: Multisystem eXtension Interface for PCI Express, Compact PCI Express, and PXI Express Bus Systems

NI PCIe-8371/8372

NI PXIe-8370

Worldwide Technical Support and Product Information

ni.com

National Instruments Corporate Headquarters

11500 North Mopac Expressway Austin, Texas 78759-3504 USA Tel: 512 683 0100

Worldwide Offices

Australia 1800 300 800, Austria 43 0 662 45 79 90 0, Belgium 32 0 2 757 00 20, Brazil 55 11 3262 3599, Canada 800 433 3488, China 86 21 6555 7838, Czech Republic 420 224 235 774, Denmark 45 45 76 26 00, Finland 385 0 9 725 725 11, France 33 0 1 48 14 24 24, Germany 49 0 89 741 31 30, India 91 80 41190000, Israel 972 0 3 6393737, Italy 39 02 413091, Japan 81 3 5472 2970, Korea 82 02 3451 3400, Lebanon 961 0 1 33 28 28, Malaysia 1800 887710, Mexico 01 800 010 0793, Netherlands 31 0 348 433 466, New Zealand 0800 553 322, Norway 47 0 66 90 76 60, Poland 48 22 3390150, Portugal 351 210 311 210, Russia 7 095 783 68 51, Singapore 1800 226 5886, Slovenia 386 3 425 4200, South Africa 27 0 11 805 8197, Spain 34 91 640 0085, Sweden 46 0 8 587 895 00, Switzerland 41 56 200 51 51, Taiwan 886 02 2377 2222, Thailand 662 278 6777, United Kingdom 44 0 1635 523545

For further support information, refer to the *Technical Support and Professional Services* appendix. To comment on National Instruments documentation, refer to the National Instruments Web site at ni.com/info and enter the info code `feedback`.

Important Information

Warranty

The NI PCIe-8371/8372 and NI PXIe-8370 are warranted against defects in materials and workmanship for a period of one year from the date of shipment, as evidenced by receipts or other documentation. National Instruments will, at its option, repair or replace equipment that proves to be defective during the warranty period. This warranty includes parts and labor.

The media on which you receive National Instruments software are warranted not to fail to execute programming instructions, due to defects in materials and workmanship, for a period of 90 days from date of shipment, as evidenced by receipts or other documentation. National Instruments will, at its option, repair or replace software media that do not execute programming instructions if National Instruments receives notice of such defects during the warranty period. National Instruments does not warrant that the operation of the software shall be uninterrupted or error free.

A Return Material Authorization (RMA) number must be obtained from the factory and clearly marked on the outside of the package before any equipment will be accepted for warranty work. National Instruments will pay the shipping costs of returning to the owner parts which are covered by warranty.

National Instruments believes that the information in this document is accurate. The document has been carefully reviewed for technical accuracy. In the event that technical or typographical errors exist, National Instruments reserves the right to make changes to subsequent editions of this document without prior notice to holders of this edition. The reader should consult National Instruments if errors are suspected. In no event shall National Instruments be liable for any damages arising out of or related to this document or the information contained in it.

EXCEPT AS SPECIFIED HEREIN, NATIONAL INSTRUMENTS MAKES NO WARRANTIES, EXPRESS OR IMPLIED, AND SPECIFICALLY DISCLAIMS ANY WARRANTY OF MERCHANTABILITY OR FITNESS FOR A PARTICULAR PURPOSE. CUSTOMER'S RIGHT TO RECOVER DAMAGES CAUSED BY FAULT OR NEGLIGENCE ON THE PART OF NATIONAL INSTRUMENTS SHALL BE LIMITED TO THE AMOUNT THEREOF PAID BY THE CUSTOMER. NATIONAL INSTRUMENTS WILL NOT BE LIABLE FOR DAMAGES RESULTING FROM LOSS OF DATA, PROFITS, USE OF PRODUCTS, OR INCIDENTAL OR CONSEQUENTIAL DAMAGES, EVEN IF ADVISED OF THE POSSIBILITY THEREOF. This limitation of the liability of National Instruments will apply regardless of the form of action, whether in contract or tort, including negligence. Any action against National Instruments must be brought within one year after the cause of action accrues. National Instruments shall not be liable for any delay in performance due to causes beyond its reasonable control. The warranty provided herein does not cover damages, defects, malfunctions, or service failures caused by owner's failure to follow the National Instruments installation, operation, or maintenance instructions; owner's modification of the product; owner's abuse, misuse, or negligent acts; and power failure or surges, fire, flood, accident, actions of third parties, or other events outside reasonable control.

Copyright

Under the copyright laws, this publication may not be reproduced or transmitted in any form, electronic or mechanical, including photocopying, recording, storing in an information retrieval system, or translating, in whole or in part, without the prior written consent of National Instruments Corporation.

National Instruments respects the intellectual property of others, and we ask our users to do the same. NI software is protected by copyright and other intellectual property laws. Where NI software may be used to reproduce software or other materials belonging to others, you may use NI software only to reproduce materials that you may reproduce in accordance with the terms of any applicable license or other legal restriction.

Trademarks

National Instruments, NI, ni.com, and LabVIEW are trademarks of National Instruments Corporation. Refer to the *Terms of Use* section on ni.com/legal for more information about National Instruments trademarks.

Other product and company names mentioned herein are trademarks or trade names of their respective companies.

Members of the National Instruments Alliance Partner Program are business entities independent from National Instruments and have no agency, partnership, or joint-venture relationship with National Instruments.

Patents

For patents covering National Instruments products, refer to the appropriate location: **Help»Patents** in your software, the `patents.txt` file on your CD, or ni.com/patents.

WARNING REGARDING USE OF NATIONAL INSTRUMENTS PRODUCTS

(1) NATIONAL INSTRUMENTS PRODUCTS ARE NOT DESIGNED WITH COMPONENTS AND TESTING FOR A LEVEL OF RELIABILITY SUITABLE FOR USE IN OR IN CONNECTION WITH SURGICAL IMPLANTS OR AS CRITICAL COMPONENTS IN ANY LIFE SUPPORT SYSTEMS WHOSE FAILURE TO PERFORM CAN REASONABLY BE EXPECTED TO CAUSE SIGNIFICANT INJURY TO A HUMAN.

(2) IN ANY APPLICATION, INCLUDING THE ABOVE, RELIABILITY OF OPERATION OF THE SOFTWARE PRODUCTS CAN BE IMPAIRED BY ADVERSE FACTORS, INCLUDING BUT NOT LIMITED TO FLUCTUATIONS IN ELECTRICAL POWER SUPPLY, COMPUTER HARDWARE MALFUNCTIONS, COMPUTER OPERATING SYSTEM SOFTWARE FITNESS, FITNESS OF COMPILERS AND DEVELOPMENT SOFTWARE USED TO DEVELOP AN APPLICATION, INSTALLATION ERRORS, SOFTWARE AND HARDWARE COMPATIBILITY PROBLEMS, MALFUNCTIONS OR FAILURES OF ELECTRONIC MONITORING OR CONTROL DEVICES, TRANSIENT FAILURES OF ELECTRONIC SYSTEMS (HARDWARE AND/OR SOFTWARE), UNANTICIPATED USES OR MISUSES, OR ERRORS ON THE PART OF THE USER OR APPLICATIONS DESIGNER (ADVERSE FACTORS SUCH AS THESE ARE HEREAFTER COLLECTIVELY TERMED "SYSTEM FAILURES"). ANY APPLICATION WHERE A SYSTEM FAILURE WOULD CREATE A RISK OF HARM TO PROPERTY OR PERSONS (INCLUDING THE RISK OF BODILY INJURY AND DEATH) SHOULD NOT BE RELIANT SOLELY UPON ONE FORM OF ELECTRONIC SYSTEM DUE TO THE RISK OF SYSTEM FAILURE. TO AVOID DAMAGE, INJURY, OR DEATH, THE USER OR APPLICATION DESIGNER MUST TAKE REASONABLY PRUDENT STEPS TO PROTECT AGAINST SYSTEM FAILURES, INCLUDING BUT NOT LIMITED TO BACK-UP OR SHUT DOWN MECHANISMS, BECAUSE EACH END-USER SYSTEM IS CUSTOMIZED AND DIFFERS FROM NATIONAL INSTRUMENTS' TESTING PLATFORMS AND BECAUSE A USER OR APPLICATION DESIGNER MAY USE NATIONAL INSTRUMENTS PRODUCTS IN COMBINATION WITH OTHER PRODUCTS IN A MANNER NOT EVALUATED OR CONTEMPLATED BY NATIONAL INSTRUMENTS, THE USER OR APPLICATION DESIGNER IS ULTIMATELY RESPONSIBLE FOR VERIFYING AND VALIDATING THE SUITABILITY OF NATIONAL INSTRUMENTS PRODUCTS WHENEVER NATIONAL INSTRUMENTS PRODUCTS ARE INCORPORATED IN A SYSTEM OR APPLICATION, INCLUDING, WITHOUT LIMITATION, THE APPROPRIATE DESIGN, PROCESS AND SAFETY LEVEL OF SUCH SYSTEM OR APPLICATION.

Compliance

Compliance with FCC/Canada Radio Frequency Interference Regulations

Determining FCC Class

The Federal Communications Commission (FCC) has rules to protect wireless communications from interference. The FCC places digital electronics into two classes. These classes are known as Class A (for use in industrial-commercial locations only) or Class B (for use in residential or commercial locations). All National Instruments (NI) products are FCC Class A products.

Depending on where it is operated, this Class A product could be subject to restrictions in the FCC rules. (In Canada, the Department of Communications (DOC), of Industry Canada, regulates wireless interference in much the same way.) Digital electronics emit weak signals during normal operation that can affect radio, television, or other wireless products.

All Class A products display a simple warning statement of one paragraph in length regarding interference and undesired operation. The FCC rules have restrictions regarding the locations where FCC Class A products can be operated.

Consult the FCC Web site at www.fcc.gov for more information.

FCC/DOC Warnings

This equipment generates and uses radio frequency energy and, if not installed and used in strict accordance with the instructions in this manual and the CE marking Declaration of Conformity*, may cause interference to radio and television reception. Classification requirements are the same for the Federal Communications Commission (FCC) and the Canadian Department of Communications (DOC).

Changes or modifications not expressly approved by NI could void the user's authority to operate the equipment under the FCC Rules.

Class A

Federal Communications Commission

This equipment has been tested and found to comply with the limits for a Class A digital device, pursuant to part 15 of the FCC Rules. These limits are designed to provide reasonable protection against harmful interference when the equipment is operated in a commercial environment. This equipment generates, uses, and can radiate radio frequency energy and, if not installed and used in accordance with the instruction manual, may cause harmful interference to radio communications. Operation of this equipment in a residential area is likely to cause harmful interference in which case the user is required to correct the interference at their own expense.

Canadian Department of Communications

This Class A digital apparatus meets all requirements of the Canadian Interference-Causing Equipment Regulations.

Cet appareil numérique de la classe A respecte toutes les exigences du Règlement sur le matériel brouilleur du Canada.

Compliance with EU Directives

Users in the European Union (EU) should refer to the Declaration of Conformity (DoC) for information* pertaining to the CE marking. Refer to the Declaration of Conformity (DoC) for this product for any additional regulatory compliance information. To obtain the DoC for this product, visit ni.com/certification, search by model number or product line, and click the appropriate link in the Certification column.

* The CE marking Declaration of Conformity contains important supplementary information and instructions for the user or installer.

Contents

About This Manual

| | |
|----------------------------|------|
| Conventions | vii |
| Related Documentation..... | viii |

Chapter 1 Introduction

| | |
|---------------------------------------|-----|
| About the MXI-Express x4 Series | 1-1 |
| Description and Features | 1-1 |
| Basic MXI-Express x4 System..... | 1-2 |
| Larger MXI-Express x4 Systems | 1-2 |
| What You Need to Get Started | 1-3 |
| Unpacking | 1-4 |

Chapter 2 Hardware Installation

| | |
|--|-----|
| Hardware Installation..... | 2-1 |
| Installing an NI PCIe-8371/8372..... | 2-1 |
| Installing an NI PXIe-8370 | 2-3 |
| Cabling | 2-4 |
| Powering Up the MXI-Express x4 System | 2-5 |
| Powering Down the MXI-Express x4 System..... | 2-5 |

Chapter 3 Hardware Overview

| | |
|---|-----|
| Functional Overview..... | 3-1 |
| Functional Unit Descriptions | 3-2 |
| PCI Express x4 Card Edge Connector..... | 3-2 |
| PCI Express Switch | 3-2 |
| Cabled MXI-Express x4 Connector | 3-3 |
| PCI Express-to-PCI Bridge | 3-3 |
| SMBus Master | 3-3 |
| LED Indicators..... | 3-3 |
| Cable Options | 3-4 |

Appendix A Specifications

**Appendix B
Common Questions**

**Appendix C
Technical Support and Professional Services**

Glossary



Index

About This Manual

This manual describes the features, functions, and operation of the MXI-Express x4 for PXI Express series of products. The products in this series are the NI PCIe-8371/8372 and the NI PXIe-8370.

Conventions

The following conventions appear in this manual:

| | |
|---|---|
| » | The » symbol leads you through nested menu items and dialog box options to a final action. The sequence File»Page Setup»Options directs you to pull down the File menu, select the Page Setup item, and select Options from the last dialog box. |
|  | This icon denotes a note, which alerts you to important information. |
|  | This icon denotes a caution, which advises you of precautions to take to avoid injury, data loss, or a system crash. |
| bold | Bold text denotes items that you must select or click in the software, such as menu items and dialog box options. Bold text also denotes parameter names. |
| CompactPCI Express/ CPCIe | The terms <i>CompactPCI Express</i> and <i>CPCIe</i> are interchangeable in this manual. |
| <i>italic</i> | Italic text denotes variables, emphasis, a cross-reference, or an introduction to a key concept. Italic text also denotes text that is a placeholder for a word or value that you must supply. |
| monospace | Text in this font denotes text or characters that you should enter from the keyboard, sections of code, programming examples, and syntax examples. This font is also used for the proper names of disk drives, paths, directories, programs, subprograms, subroutines, device names, functions, operations, variables, filenames and extensions, and code excerpts. |
| NI PCIe-8370 | The name <i>NI PCIe-8370</i> may be used in this manual when the material would refer to either the NI PCIe-8371 or NI PCIe-8372. |
| PCI Express/PCIe | The terms <i>PCI Express</i> and <i>PCIe</i> are interchangeable in this manual. |

| | |
|---------------------|---|
| PXI Express chassis | In this manual, whenever a PXI Express chassis is referenced, a CompactPCI Express chassis could be used instead. |
| PXI Express/PXIe | The terms <i>PXI Express</i> and <i>PXIe</i> are interchangeable in this manual. |

Related Documentation

The following documents contain information that you might find helpful as you read this manual:

- *Set Up Your MXI-Express System*
- Your computer or chassis documentation
- *PXI Express Hardware Specification*, Revision 1.0
- *PXI-2 PXI Software Specification*, Revision 2.1
- *PXI-6 PXI Express Software Specification*
- *PCI Specification*, Revision 2.3
- *PCI-PCI Bridge Architecture Specification*, Revision 1.1
- *PICMG CompactPCI Express EXP.0 R1.0 Specification*
- *PCI Express Specification*, Revision 1.0a

Introduction

This chapter describes the MXI-Express x4 series of products, lists what you need to get started, and explains how to unpack and set up your hardware.

The MXI-Express x4 series is an extension of the MXI-Express series of remote controllers. The two products in this series are the NI PCIe-8371/8372 and NI PXIe-8370. For the remainder of this manual the term *MXI-Express x4* refers to any product in the MXI-Express x4 series.

MXI-Express x4 cards must always be installed as a PCI Express card and a PXI Express card.

About the MXI-Express x4 Series

Description and Features

MXI-Express x4 uses PCI Express signals over a cable of up to 7 m with a PCI Express-to-PCI Express switch. You can do the following with MXI-Express x4:

- Control a PXI Express or CompactPCI Express backplane with a PCI Express-based PC
- Physically separate the measurement or automation system from a host PC

Basic MXI-Express x4 System

The simplest MXI-Express x4 system consists of an NI PCIe-8371/8372 in a PC connected to an NI PXIe-8370 in the controller slot of a PXI Express or CompactPCI Express chassis, as shown in Figure 1-1.

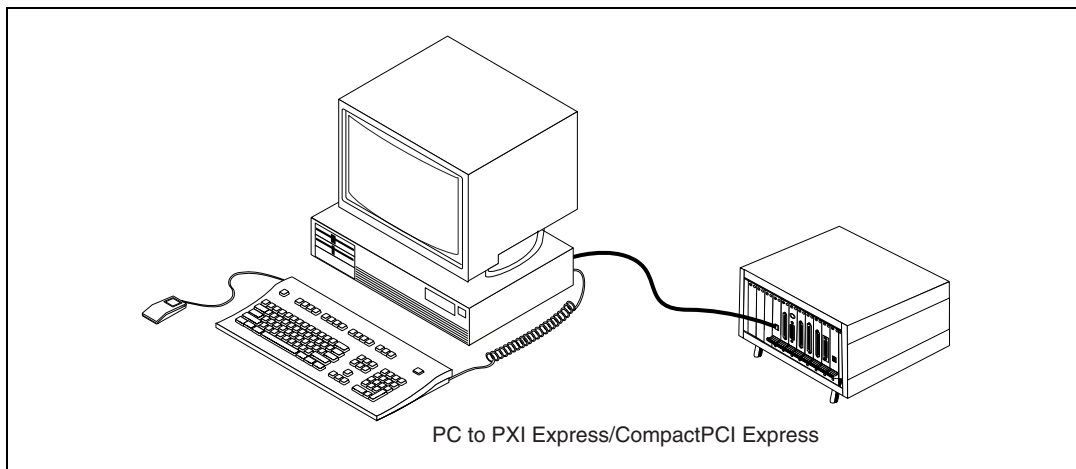

Figure 1-1. Basic MXI-Express x4 Configuration

Larger MXI-Express x4 Systems

The NI PCIe-8372 has two MXI-Express x4 connectors, allowing one NI PCIe-8372 to host two different NI PXIe-8370 cards in separate PXI Express or CompactPCI Express chassis. If multiple PCI Express slots are available in the host PC, additional PXI Express chassis can be connected by installing an additional NI PCIe-8371/8372 in any available PCI Express slot.

Figure 1-2 shows how you can use MXI-Express x4 cards to connect multiple CPCIe or PXIe expansion chassis to a PC in a star topology. The star topology is the only supported topology due to the point-to-point nature of PCI Express.

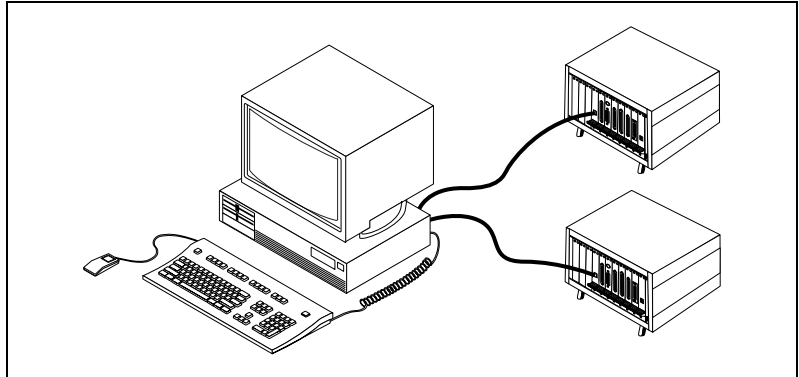

Figure 1-2. Star Topology MXI-Express x4 Configuration

What You Need to Get Started

To set up and use your MXI-Express x4 cards, you need the following:

- One NI PCIe-8371/8372 and one NI PXIe-8370
- A MXI-Express x4 cable
- A host PC with an available x4 (or wider) PCI Express slot



Note Using a PCI Express slot wider than x4 may result in negotiation down to x1 width.

- An expansion chassis—the PXI Express or CompactPCI Express chassis that you control with MXI-Express x4



Note Your PXI Express MXI-Express x4 card will work in any standard CompactPCI Express chassis adhering to the *PICMG CompactPCI Express EXP.0 R1.0 Specification*, or in a PXI Express chassis compatible with the *PXI Express Hardware Specification*, Revision 1.0 or later. Your PCI Express MXI-Express x4 card will work in systems compliant with the *PCI Express Specification*, Revision 1.0a or later.

Unpacking

Your MXI-Express x4 cards are shipped in antistatic packages to prevent electrostatic damage (ESD) to the devices. ESD can damage several components on the device.



Caution *Never* touch the exposed pins of connectors. Doing so may damage the device.

To avoid such damage in handling the device, take the following precautions:

- Ground yourself using a grounding strap or by holding a grounded object.
- Touch the antistatic package to a metal part of the computer chassis before removing the device from the package.

Remove the device from the package and inspect the device for loose components or any sign of damage. Notify NI if the device appears damaged in any way. Do *not* install a damaged device into the computer or into a PXI Express or CompactPCI Express chassis.

Store the device in the antistatic envelope when not in use.

Hardware Installation

This chapter explains how to install the MXI-Express x4 hardware.

Hardware Installation

The following are general instructions for installing the MXI-Express x4 cards. Consult your computer user manual or technical reference manual for specific instructions and warnings.



Note The PXI Platform Services software on the *PXI Platform Services* CD or driver CD included with your PXI Express MXI-Express x4 hardware is required to provide chassis and controller identification for PXI features such as trigger routing and slot detection. The PXI Platform Services software is also included with the NI-DAQmx and NI-VISA drivers. For more information, refer to KnowledgeBase 3TJDONDS at ni.com.

Installing an NI PCIe-8371/8372

1. Power off your computer, but leave it plugged in while installing the NI PCIe-8371/8372. The power cord grounds the computer and protects it from electrical damage while you install the card.



Caution To protect both yourself and the computer from electrical hazards, your computer should remain off until you finish installing the NI PCIe-8371/8372.

2. Remove the top cover or access port to the PCI Express bus.
3. Select any available PCI Express expansion slot (x4 or wider).



Notes Using a PCI Express slot wider than x4 may result in negotiation down to x1 width.

The BIOS or motherboard may not support the NI PCIe-8371/8372 in a slot intended for a graphics card.

4. Locate the metal bracket that covers the cut-out in the back panel of the computer for the slot you have selected. Remove and save the bracket-retaining screw and the bracket cover.

5. Touch the metal part of the power supply case inside the computer to discharge any static electricity that might be on your clothes or body.
6. Line up the NI PCIe-8371/8372 with the slot on the back panel. Slowly lower the NI PCIe-8371/8372 until its card-edge connector is resting on the expansion slot receptacle. Using slow, evenly distributed pressure, press the NI PCIe-8371/8372 straight down until it seats in the expansion slot.
7. Reinstall the bracket-retaining screw to secure the NI PCIe-8371/8372 to the back panel rail.
8. Replace the computer cover.

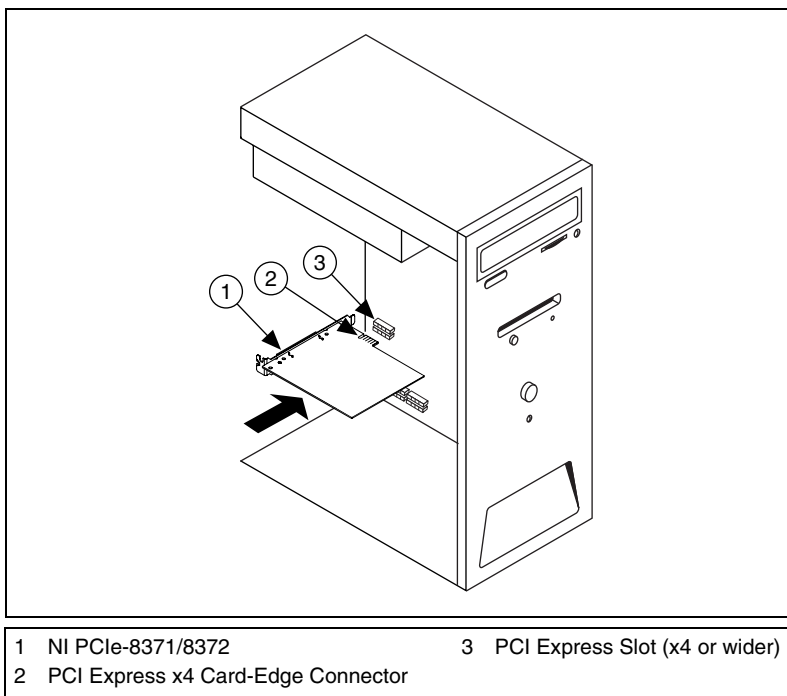

Figure 2-1. Installing the NI PCIe-8371/8372

Installing an NI PXIe-8370

Complete the following steps to install the NI PXIe-8370 in your PXI Express or CompactPCI Express chassis.

1. Power off your PXI Express or CompactPCI Express chassis, but leave it plugged in while installing the NI PXIe-8370. The power cord grounds the chassis and protects it from electrical damage while you install the module.
2. Locate the System Controller slot of the chassis. The NI PXIe-8370 must be installed in the controller slot (slot 1 in a PXI Express chassis).



Caution To protect both yourself and the chassis from electrical hazards, leave the chassis off until you finish installing the NI PXIe-8370.

3. Remove or open any doors or covers blocking access to the slot in which you intend to install the NI PXIe-8370.
4. Touch the metal part of the case to discharge any static electricity that might be on your clothes or body.
5. Make sure the injector/ejector handle is in its downward position. Be sure to remove all connector packaging and protective caps from retaining screws on the module. Align the NI PXIe-8370 with the card guides on the top and bottom of the system controller slot.



Caution Do *not* raise the injector/ejector handle as you insert the NI PXIe-8370. It will not insert properly unless the handle is in its downward position so that it does not interfere with the injector/ejector rail on the chassis, as shown in Figure 2-2.

6. Hold the handle as you slowly slide the module into the chassis until the handle catches on the injector/ejector rail.
7. Raise the injector/ejector handle until the module firmly seats into the backplane receptacle connectors. The front panel of the NI PXIe-8370 should be even with the front panel of the chassis.



Note LEDs on the back side of the PXI-8370 card will light, indicating the presence of 5V auxiliary power.

8. Tighten the bracket-retaining screws on the top and bottom of the front panel to secure the NI PXIe-8370 to the chassis.
9. Replace or close any doors or covers to the chassis.

Figure 2-2 shows an NI PXIe-8370 just before installation in the system controller slot of a National Instruments PXI Express chassis.

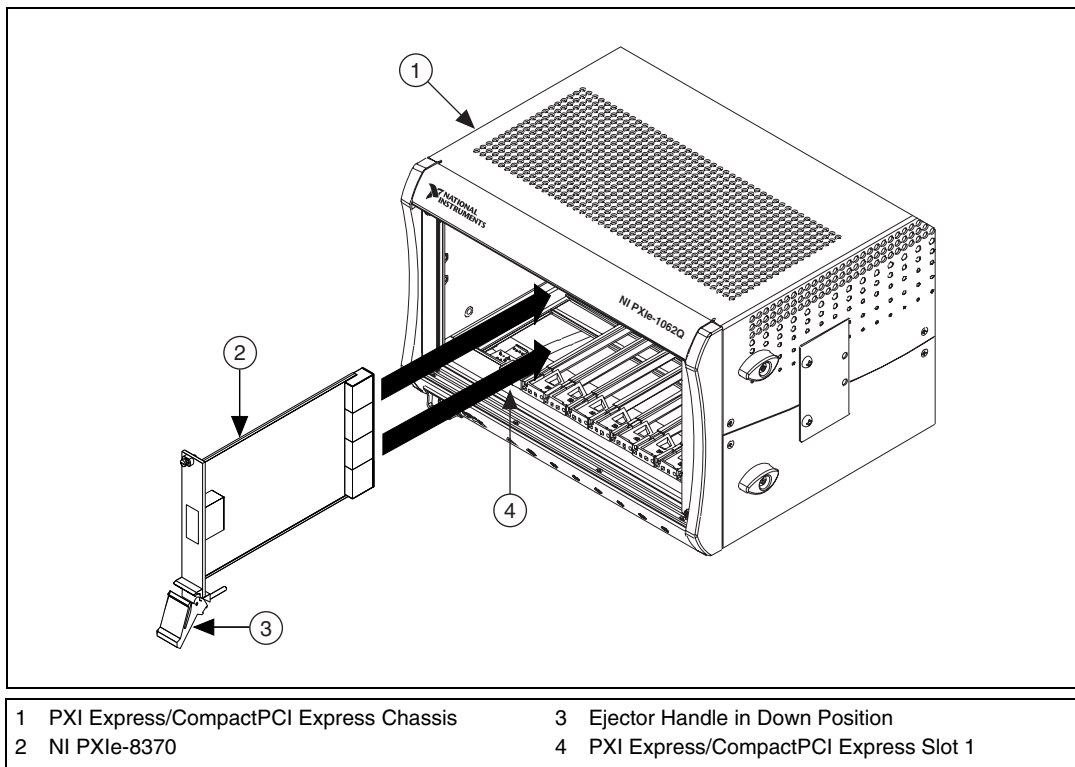

Figure 2-2. NI PXIe-8370 Card Before Installation

Cabling

Connect the MXI-Express x4 cable to both MXI-Express x4 cards. The cables have no polarity, so either end may be connected to either card.



Caution Do *not* remove the cable after the system is powered on. Doing so can hang or cause errors in applications communicating with devices behind MXI-Express x4. If a cable becomes unplugged, plug it back into the system. (You may need to restart your computer.)



Note For more information about cables, refer to the [Cable Options](#) section of Chapter 3, [Hardware Overview](#).

Powering Up the MXI-Express x4 System

1. Power-on all of the expansion chassis in any order you choose.
2. Power-on the host.

Typical PCI-PCI bridges and switches are used to add PCI devices to a PCI hierarchy in which all the bridges and devices are contained within a single chassis. Because of this, BIOSes and operating systems make the assumption that all PCI devices in the entire hierarchy will be available as soon as code execution begins at power-up. This assumption means that all of the expansion chassis must be turned on before the host PC for the BIOS and OS to correctly configure a MXI-Express x4 system.



Note There are no requirements on how MXI-Express x4 expansion chassis are powered up relative to each other, as long as they are all on before the computer is powered on.

Powering Down the MXI-Express x4 System

Because operating systems and drivers commonly make the assumption that PCI devices will be present in the system from power-up to power-down, it is important to not power off the expansion chassis until after the host PC is powered off. Powering off the expansion chassis while the host is still on can cause crashes or hangs. The order in which expansion chassis are powered off, relative to each other, is not important.

Hardware Overview

This chapter presents an overview of MXI-Express x4 hardware functionality and explains the operation of each functional unit.

Functional Overview

MXI-Express x4 is based on PCI Express technology. A MXI-Express x4 kit uses PCI Express switches to enable control of a PXI Express or CompactPCI Express chassis from a PC with an available PCI Express slot. The PCI Express switch architecture is transparent to device drivers, so no additional software is needed to support using PXI Express and CompactPCI Express devices in a chassis connected using MXI-Express x4.



Note The PXI Platform Services software on the *PXI Platform Services* CD or driver CD included with your PXI Express MXI-Express x4 hardware is required to provide chassis and controller identification for PXI features such as trigger routing and slot detection. The PXI Platform Services software is also included with the NI-DAQmx and NI-VISA drivers. For more information, refer to KnowledgeBase 3TJDONDS at ni.com.

The link between the PC and the chassis is a x4 PCI Express link. This link is a dual-simplex communication channel comprised of low-voltage, differentially driven signal pairs. The link can transmit at a rate of 10 Gbps in each direction simultaneously. This connector is compatible with the cabled PCI Express specification under development by the PCI-SIG.

Figure 3-1 shows the basic architecture of MXI-Express x4. The NI PCIe-8371/8372 consists of a PCI Express x4 card edge connector, a PCI Express switch, and one or two cabled MXI-Express x4 connectors. The NI PXIe-8370 consists of one cabled MXI-Express x4 connector, a PCI Express switch, and PXI Express connectors.

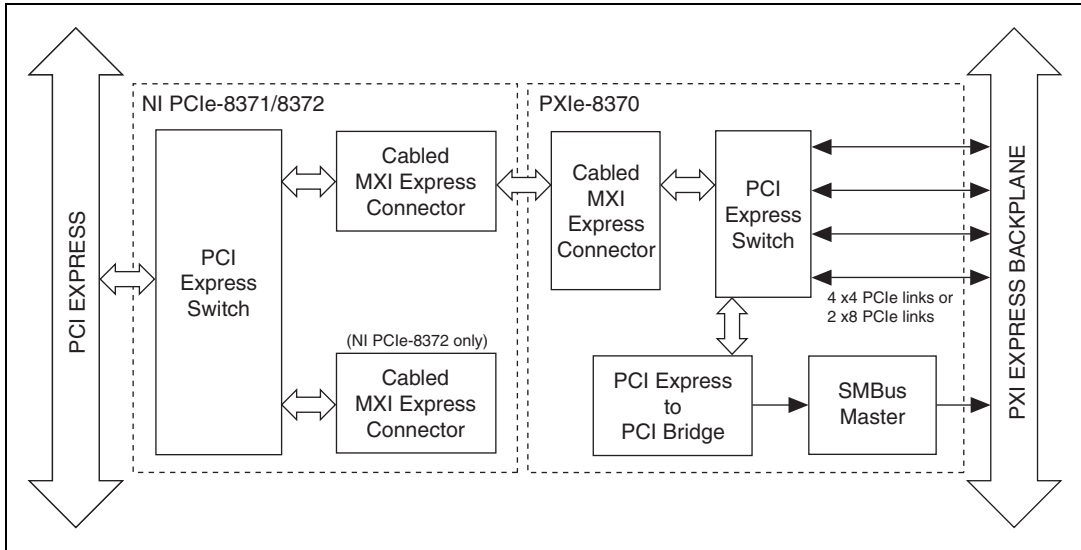

Figure 3-1. MXI-Express x4 Block Diagram

Functional Unit Descriptions

PCI Express x4 Card Edge Connector

The card edge connector allows you to use the NI PCIe-8371/8372 in a x4 or wider PCI Express slot in a PC. The PCI Express Card Electromechanical Specification defines this connector.

PCI Express Switch

The PCI Express Base Specification defines a PCI Express switch as a logical collection of PCI Express-to-PCI Express bridge devices. On the NI PCIe-8371/8372, the upstream port of the switch is connected to the PCI Express x4 card edge connector, and the two downstream ports are connected to the two cabled MXI-Express x4 connectors.

On the NI PXIe-8370, the upstream part of the switch is connected to the cable. One downstream port is connected to the SMBus Master, and either 4 x4 ports or 2 x8 ports are connected to the backplane, depending on the chassis backplane configuration.

Cabled MXI-Express x4 Connector

The cabled MXI-Express x4 connector provides all necessary signals to connect an NI PCIe-8371/8372 and an NI PXIe-8370. These signals include the PCI Express transmit and receive pairs, the system clock, presence detect signals, reset, and a wake-up signal. This connector is compatible with the 0.7 draft of the cabled PCI Express specification being defined by the PCI-SIG.

PCI Express-to-PCI Bridge

The PCI Express Base Specification defines a PCI Express-to-PCI bridge as a device that connects a PCI Express fabric and a PCI hierarchy. On the NI PXIe-8370, the PCI Express-to-PCI bridge connects the x4 PCI Express link and an SMBus Master on the card.

SMBus Master

The SMBus is a low-speed bus for reading and configuring devices outside the normal PCI Express mechanism. The PXI Express specification requires controllers to supply an SMBus for reading chassis configuration information from an EPROM. It may also be used for fan control, power monitors, or other system devices. In addition, devices on plug-in boards may connect to the SMBus for purposes specific to those devices.

LED Indicators

The LEDs on MXI-Express x4 cards give status information about power supplies and link state. The NI PCIe-8372 has two tri-color LEDs, one for each port on the panel. The NI PXIe-8370 has two LEDs, one for power supply status and one for link state.

The LEDs on the NI PCIe-8372 indicate the following:

Table 3-1. NI PCIe-8372 Status LED Messages

| Color | Meaning |
|-------|--|
| Off | Power is off |
| Red | Power is out of spec |
| Amber | Power is within spec; no link to chassis |
| Green | Power is within spec; link established |

The front-panel LEDs on the NI PXIe-8370 indicate the following:

Table 3-2. NI PXIe-8370 Status LED Messages

| LED | Color | Meaning |
|------|---------------|----------------------|
| PWR | Off | No power |
| | Red, blinking | Power is out of spec |
| | Green | Power is within spec |
| LINK | Off | Link not established |
| | Green | Link established |

The NI PXIe-8370 has some additional LEDs on the back side of the board near the front-panel connector. These LEDs give additional information about the link status of the PCI Express lanes on the module to the backplane. For more information, refer to KnowledgeBase 3U7CDCD8 at ni.com.

Cable Options

MXI-Express x4 is available with cables of various lengths. Table 3-3 shows the cables available from National Instruments.

Table 3-3. National Instruments MXI-Express x4 Cables

| Cable Length (Meters) | Description |
|-----------------------|---|
| 3 m | MXI-Express x4 copper cable (part number 779725-03) |
| 7 m | MXI-Express x4 copper cable (part number 779725-07) |

Specifications

This appendix lists the system specifications for NI PCIe-8371/8372 and NI PXIe-8370 cards. These specifications are typical at 25 °C, unless otherwise stated.

Physical

Dimensions

NI PXIe-8370..... 10.0 × 16.0 cm (3.9 × 6.3 in.)

NI PCIe-8371/8372..... 10.7 × 17.5 cm (4.4 × 6.9 in.)

Maximum cable length..... 7 m

Slot requirements

NI PXIe-8370..... One system slot (PXI Express or CompactPCI Express)

NI PCIe-8371/8372..... One slot (PCI Express)

Compatibility Fully compatible with the *PXI Express Hardware Specification, Revision 1.0* and the *PICMG CompactPCI Express EXP.0 R1.0 Specification*

Weight

NI PXIe-8370..... 0.17 Kg (0.37 lb) typical

NI PCIe-8371/8372..... 0.19 Kg (0.42 lb) typical

Power requirements

NI PXIe-8370

| Power Rail | Typical Current | Maximum Current |
|------------|-----------------|-----------------|
| +3.3 V | 2.5 A | 3 A |
| +5 V | 0 mA | 5 mA |

| Power Rail | Typical Current | Maximum Current |
|---------------------|-----------------|-----------------|
| +12 V | 0 mA | 1 mA |
| +5 V _{aux} | 0.3 A | 0.4 A |

NI PCIe-8371/8372

| Power Rail | Typical Current | Maximum Current |
|-----------------------|-----------------|-----------------|
| +3.3 V | 1.800 A | 2.000 A |
| +3.3 V _{aux} | 1 mA | 25 mA |
| +12 V | 0 A | 0 A |

Environment

NI PXIe-8370

Maximum altitude.....2,000 m (800 mbar)
(at 25 °C ambient temperature)

Pollution Degree2

Indoor use only.

Operating Environment

Ambient temperature range0 to 55 °C (Tested in accordance with IEC-60068-2-1 and IEC-60068-2-2. Meets MIL-PRF-28800F Class 3 low temperature limit and MIL-PRF-28800F Class 2 high temperature limit.)

Relative humidity range.....10 to 90%, noncondensing
(Tested in accordance with IEC-60068-2-56)

Storage Environment

| | |
|--------------------------------|--|
| Ambient temperature range..... | -40 to 71 °C (Tested in accordance with IEC-60068-2-1 and IEC-60068-2-2. Meets MIL-PRF-28800F Class 3 limits.) |
| Relative humidity range | 5 to 95%, noncondensing (Tested in accordance with IEC-60068-2-56) |

Shock and Vibration

| | |
|-------------------------|--|
| Operational shock | 30 g peak, half-sine, 11 ms pulse (Tested in accordance with IEC-60068-2-27. Meets MIL-PRF-28800F Class 2 limits.) |
|-------------------------|--|

Random Vibration

| | |
|-------------------|--|
| Operating..... | 5 to 500 Hz, 0.3 g _{rms} |
| Nonoperating..... | 5 to 500 Hz, 2.4 g _{rms} (Tested in accordance with IEC-60068-2-64. Nonoperating test profile exceeds the requirements of MIL-PRF-28800F, Class 3.) |

NI PCIe-8371/8372

| | |
|------------------------|--|
| Maximum altitude | 2,000 m (at 25 °C ambient temperature) |
| Pollution Degree | 2 |

Indoor use only

Operating Environment

| | |
|--------------------------------|--|
| Ambient temperature range..... | 0 to 40 °C (Tested in accordance with IEC-60068-2-1 and IEC-60068-2-2) |
| Relative humidity range | 10 to 90%, noncondensing (Tested in accordance with IEC-60068-2-56) |

Storage Environment

Ambient temperature range-20 to 70 °C (Tested in accordance with IEC-60068-2-1 and IEC-60068-2-2)

Relative humidity range.....5 to 95%, noncondensing (Tested in accordance with IEC-60068-2-56)



Caution Clean the NI PXIe-8370 and NI PCIe-8371/8372 with a soft nonmetallic brush. Make sure that the device is completely dry and free from contaminants before returning it to service.



Note For full EMC compliance, operate this device with shielded cabling. In addition, all covers and filler panels must be installed. To obtain the DoC for this product, visit ni.com/certification, search by model number or product line, and click the appropriate link in the Certification column.

Safety

This product is designed to meet the requirements of the following standards of safety for electrical equipment for measurement, control, and laboratory use:

- EN 61010-1, IEC 61010-1
- UL 61010-1, CAN/CSA-C22.2 No. 61010-1



Note For UL and other safety certifications, refer to the product label, or visit ni.com/certification, search by model number or product line, and click the appropriate link in the Certification column.

Electromagnetic Compatibility

This product is designed to meet the requirements of the following standards of EMC for electrical equipment for measurement, control, and laboratory use:

- EN 61326 EMC requirements; Minimum Immunity
- EN 55011 Emissions; Group 1, Class A
- CE, C-Tick, ICES, and FCC Part 15 Emissions; Class A



Note For EMC compliance, operate this device according to printed documentation.

CE Compliance

This product meets the essential requirements of applicable European Directives, as amended for CE marking, as follows:

- 73/23/EEC; Low-Voltage Directive (safety)
- 89/336/EEC; Electromagnetic Compatibility Directive (EMC)



Note Refer to the Declaration of Conformity (DoC) for this product for any additional regulatory compliance information. To obtain the DoC for this product, visit ni.com/certification, search by model number or product line, and click the appropriate link in the Certification column.

Waste Electrical and Electronic Equipment (WEEE)



EU Customers At the end of their life cycle, all products *must* be sent to a WEEE recycling center. For more information about WEEE recycling centers and National Instruments WEEE initiatives, visit ni.com/environment/weee.htm.

Common Questions

This appendix lists common questions related to the use of the MXI-Express x4 controllers.

General Hardware

What are the board names of the MXI-Express x4 remote controllers?

- NI PCIe-8371/8372: PCI Express MXI-Express x4 interface
- NI PXIe-8370: PXI Express MXI-Express x4 interface

How many PXI bus segments can I connect together with MXI-Express x4?

The PCI specification allows up to 255 bus segments. MXI-Express x4 does not limit this number, but the maximum number of bus segments allowed can be BIOS or operating system dependent. Also, a computer may already have several PCI bus segments internally, and the MXI-Express x4 link also has multiple PCI buses internally. Every PCI Express device has at least 1 bus segment, though it will have more if it includes a bridge or switch.

What host PCs are compatible with MXI-Express x4 for PXI Express?

Refer to KnowledgeBase 3U7CI4D8 at ni.com.



Note Due to the point-to-point nature of PCI Express, MXI-Express x4 supports only the star configuration. You must use traditional MXI for the daisy chain configuration.

General Cabling

What is the maximum length of a MXI-Express x4 copper cable?

The maximum length for a MXI-Express x4 copper cable is 7 m. National Instruments offers 3 m and 7 m copper cables.

General Software

Under which operating systems will MXI-Express x4 work?

MXI-Express x4 will be recognized as a collection of PCI-to-PCI bridges to the majority of operating systems. It should automatically work with most systems like Windows, Macintosh OS X, Linux, and Solaris, but only Windows XP has been verified in the initial release of MXI-Express x4.

What software is required to use my MXI-Express x4 kit?

For Windows and LabVIEW RT, the required software is included as part of the latest version of NI PXI Platform Services included with your kit. The software for your MXI-Express x4 controller enhances the product, allowing you to view information about the organization of your PXI system and programmatically retrieve data about the chassis and modules you have installed.

If the MXI-Express x4 software does not support your operating system, you can still use MXI-Express x4 and the operating system will provide a mechanism for you to ignore the SMBus master that is built into the MXI-Express x4 hardware.

MXI-3 required optimization software. Does MXI-Express x4 require the same?

No. The necessary optimization is now done automatically by the MXI-Express x4 hardware.

How does my MXI-Express x4 board show up in the Windows Device Manager?

MXI-Express x4 boards contain two types of PCI devices onboard and will have several listings in the Windows Device Manager (WDM). The first devices show up in the WDM listed under System devices as **PCI standard PCI-to-PCI bridges**. The second device type shows up in the WDM as an **NI PXIe-8370 SMBus Controller** when the correct MXI-Express x4 driver is installed. This second device provides configuration information about the chassis. The NI PCIe-8371 includes two PCI standard PCI-to-PCI bridges. The NI PCIe-8372 includes three PCI standard

PCI-to-PCI bridges. The NI PXIe-8370 includes five to seven bridges and one NI PXIe-8370 SMBus Controller device.

If the MXI-Express x4 software is not installed, the PCI-to-PCI function will still be detected and work correctly, but the SMBus master will be detected as an unknown device.

MXI-3 and MXI-4 to MXI-Express x4 Upgrade Questions

What are some of the improvements from MXI-3 and MXI-4 to MXI-Express x4?

MXI-Express x4 incorporates the latest technology to include:

- Support for PCI Express slots.
- Support for PXI Express and CompactPCI Express chassis.
- Improved error correction and handling for noisy or harsh environments.
- Improved mechanical connectivity.
- Improved performance.
- Support for two chassis from a single card in the host PC.

Can a MXI-3, MXI-4, and MXI-Express x4 board be used together directly?

No. MXI-3, MXI-4, and MXI-Express x4 boards use different cable connectors and cannot be connected together. Additionally, the board-to-board communication protocols differ.

Can I use a MXI-3, MXI-4, and MXI-Express x4 kit in the same multichassis PXI system?

Yes. Different MXI kits can be intermixed to connect multiple PXI and PXI Express chassis together. As mentioned previously, an individual MXI-3 or MXI-4 board will not cable directly to a MXI-Express x4 board.

MXI-3 and MXI-4 systems required the use of a specific boot ordering. Is this a requirement with MXI-Express x4?

Yes. The requirements of the PCI bus still mandate that you must power-on secondary PXI/PXIe chassis before powering on the host PC when using MXI-Express x4.

With MXI-3 and several chassis connected in series (daisy chain configuration), you were required to power-on the chassis in order starting with the chassis at the end of the chain and move towards the host controller. Now with MXI-Express x4, multiple chassis are connected in parallel and can be powered on in any order, except that you need to ensure that the last component powered on is the host PC.

For more details, refer to the *Powering Up the MXI-Express x4 System* section of Chapter 2, *Hardware Installation*.



Technical Support and Professional Services

Visit the following sections of the National Instruments Web site at ni.com for technical support and professional services:

- **Support**—Online technical support resources at ni.com/support include the following:
 - **Self-Help Resources**—For answers and solutions, visit the award-winning National Instruments Web site for software drivers and updates, a searchable KnowledgeBase, product manuals, step-by-step troubleshooting wizards, thousands of example programs, tutorials, application notes, instrument drivers, and so on.
 - **Free Technical Support**—All registered users receive free Basic Service, which includes access to hundreds of Application Engineers worldwide in the NI Developer Exchange at ni.com/exchange. National Instruments Application Engineers make sure every question receives an answer.

For information about other technical support options in your area, visit ni.com/services or contact your local office at ni.com/contact.

- **Training and Certification**—Visit ni.com/training for self-paced training, eLearning virtual classrooms, interactive CDs, and Certification program information. You also can register for instructor-led, hands-on courses at locations around the world.
- **System Integration**—If you have time constraints, limited in-house technical resources, or other project challenges, National Instruments Alliance Partner members can help. To learn more, call your local NI office or visit ni.com/alliance.
- **Declaration of Conformity (DoC)**—A DoC is our claim of compliance with the Council of the European Communities using the manufacturer's declaration of conformity. This system affords the user protection for electronic compatibility (EMC) and product safety. You can obtain the DoC for your product by visiting ni.com/certification.

- **Calibration Certificate**—If your product supports calibration, you can obtain the calibration certificate for your product at ni.com/calibration.

If you searched ni.com and could not find the answers you need, contact your local office or NI corporate headquarters. Phone numbers for our worldwide offices are listed at the front of this manual. You also can visit the Worldwide Offices section of ni.com/niglobal to access the branch office Web sites, which provide up-to-date contact information, support phone numbers, email addresses, and current events.

Glossary

| Symbol | Prefix | Value |
|--------|--------|-----------|
| n | nano | 10^{-9} |
| μ | micro | 10^{-6} |
| m | milli | 10^{-3} |
| k | kilo | 10^3 |
| M | mega | 10^6 |

Symbols

| | |
|--------|-----------------------|
| ° | Degrees |
| \geq | Equal or greater than |
| \leq | Equal or less than |
| % | Percent |

B

| | |
|------------|---|
| bus | the group of conductors that interconnect individual circuitry in a computer. Typically, a bus is the expansion vehicle to which I/O or other devices are connected. Examples of PC buses are the PCI, PCI Express, AT bus, NuBus, Micro Channel, and EISA bus. |
| bus master | a type of a plug-in board or controller with the ability to read and write devices on the computer bus |

C

| | |
|---------------|---|
| C | Celsius |
| clock | hardware component that controls timing for reading from or writing to groups |
| counter/timer | a circuit that counts external pulses or clock pulses (timing) |

D

device a plug-in instrument card or pad that can contain multiple channels and conversion devices. Plug-in boards and PCMCIA cards are examples of devices.

digital trigger a TTL level signal having two discrete levels—a high and a low level

DMA Direct Memory Access—a method by which data can be transferred to/from computer memory from/to a device or memory on the bus while the processor does something else. DMA is the fastest method of transferring data to/from computer memory.

F

FPGA Field Programmable Gate Array—a logic device that has its functionality defined after it is manufactured.

I

IEEE Institute of Electrical and Electronics Engineers

P

PCI Peripheral Component Interconnect—a high-performance expansion bus architecture originally developed by Intel to replace ISA and EISA. It is achieving widespread acceptance as a standard for PCs and workstations; it offers a theoretical maximum transfer rate of 132 Mbytes/s.

PCI Express a scalable full-simplex serial bus standard that operates at 2.5 Gbps and offers both asynchronous and isochronous data transfers

PCI-PCI bridge a device that transparently expands the PCI bus on a computer motherboard to another bus segment in the same machine. The bridge expands the number of PCI expansion slots, but remains transparent to the end user.

PXI PCI eXtensions for Instrumentation. PXI is an open specification that builds off the CompactPCI specification by adding instrumentation-specific features.

X

x4 a link or port with four physical lanes

Index

A

additional MXI-Express x4 configuration
(figure), 1-3

B

basic MXI-Express x4 configuration
(figure), 1-2
basic MXI-Express x4 system, 1-2
block diagram (figure), 3-2

C

cable options (table), 3-4
cabled MXI-Express x4 connector, 3-3
cabling common questions, B-1
calibration certificate (NI resources), C-2
card edge connector, 3-2
CE compliance specifications, A-5
cleaning, A-4
common questions
 general cabling, B-1
 general hardware, B-1
 general software, B-2
 MXI-3 to MXI-Express x4, B-3
configuration, additional
 star (figure), 1-3
configuration, basic (figure), 1-2
conventions used in the manual, *vii*

D

Declaration of Conformity (NI resources), C-1
diagnostic tools (NI resources), C-1
documentation
 conventions used in manual, *vii*

NI resources, C-1
 related documentation, *viii*
drivers (NI resources), C-1

E

electromagnetic compatibility, A-4
environmental specifications, A-2
 NI PCIe-8371/8372, A-3
 NI PXIe-8370, A-2
examples (NI resources), C-1

F

functional unit descriptions, 3-2

G

getting started, 1-3

H

hardware common questions, B-1
help, technical support, C-1

I

installation
 cabling, 2-4
 hardware, 2-1
 of an NI PCIe-8371/8372, 2-1
 of an NI PXIe-8370, 2-3
 powering down the MXI-Express x4
 system, 2-5
 powering up the MXI-Express x4
 system, 2-5
instrument drivers (NI resources), C-1

K

KnowledgeBase, C-1

L

larger MXI-Express x4 systems, 1-2

LED indicators, 3-3

M

MXI-3 to MXI-Express x4 common questions, B-3

MXI-Express x4

- basic system, 1-2

- block diagram (figure), 3-2

- cable options (table), 3-4

- hardware overview, 3-1

- larger systems, 1-2

- specifications, A-1

- system

 - description, 1-1

 - getting started, 1-3

N

National Instruments support and services, C-1

NI PCIe-8371/8372

- installation, 2-1

- figure, 2-2

NI PXIe-8370

- installation, 2-3

- figure, 2-4

NI support and services, C-1

O

operating environment specifications

- NI PCIe-8371/8372, A-3

- NI PXIe-8370, A-2

overview

- functional, 3-1

- functional unit descriptions, 3-2

- hardware, 3-1

P

PCI Express switch, 3-2

PCI Express x4 card edge connector, 3-2

PCI Express-to-PCI bridge, 3-3

physical specifications, A-1

programming examples (NI resources), C-1

R

random vibration specifications

- NI PXIe-8370, A-3

related documentation, *viii*

S

safety specifications, A-4

shock and vibration specifications

- NI PXIe-8370, A-3

SMBus Master, 3-3

software

- common questions, B-2

- NI resources, C-1

specifications

- CE compliance, A-5

- cleaning, A-4

- electromagnetic compatibility, A-4

- environmental, A-2

 - NI PCIe-8371/8372, A-3

 - NI PXIe-8370, A-2

- physical, A-1

- safety, A-4

- waste electrical and electronic equipment, A-5

storage environment specifications

- NI PCIe-8371/8372, A-4

NI PXIe-8370, A-3
support, technical, C-1
switch, PCI Express, 3-2

T

technical support, C-1
training and certification (NI resources), C-1
troubleshooting (NI resources), C-1

U

unpacking, 1-4

W

waste electrical and electronic equipment
specifications, A-5
Web resources, C-1