

# QUICK START GUIDE

# BNC-2090A

## Rack-Mount Connector Accessory for E/M Series DAQ Devices

The National Instruments BNC-2090A is a desktop or rack-mount analog breakout accessory you can connect to E/M Series multifunction DAQ devices. This quick start guide describes how to install and configure your BNC-2090A accessory with a DAQ device.

Refer to the *BNC-2090A User Manual* for in-depth information about accessory installation, cable connections, jumper settings, signals, and signal conditioning, as well as accessory specifications.

Figure 1 shows the BNC-2090A front panel and enclosure back.

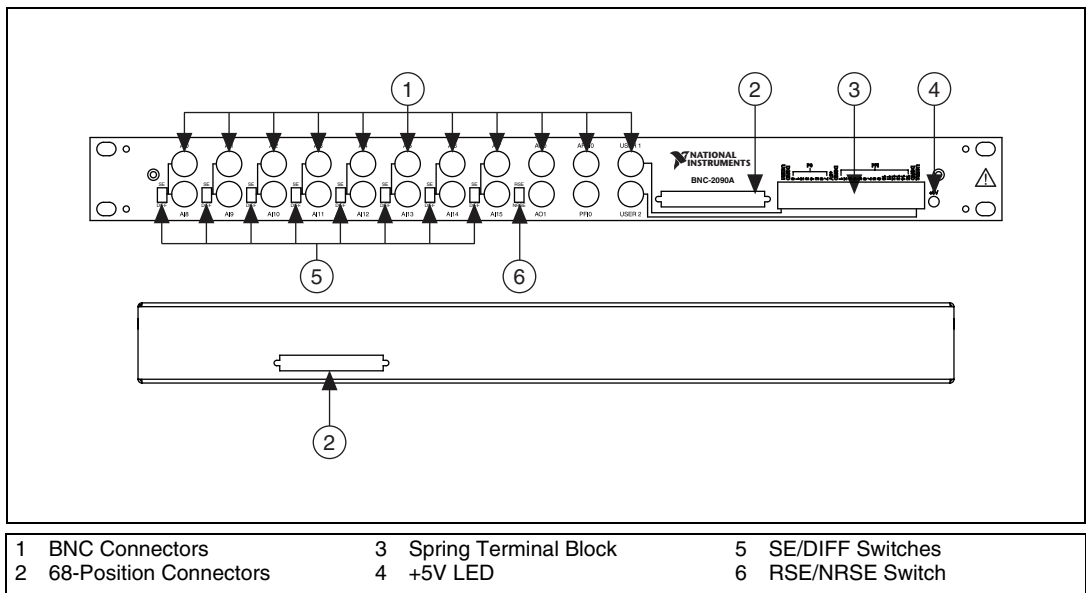

**Figure 1.** BNC-2090A Front Panel and Back of Enclosure

# Installing the BNC-2090A

To connect the BNC-2090A to your DAQ device, refer to Figure 2 as you complete the following steps. Consult your computer user manual or technical reference manual for specific instructions and warnings.



**Note** If you have not already installed your DAQ device, refer to the *DAQ Getting Started Guide* for instructions.

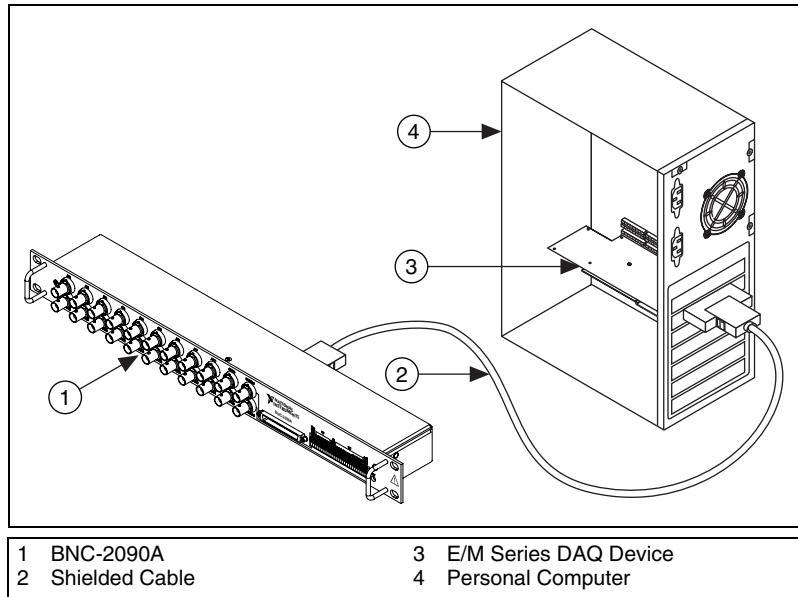

**Figure 2.** Connecting the BNC-2090A to Your DAQ Device

1. Place the BNC-2090A near the host computer or mount the BNC-2090A into a 19 inch rack. If you do not rack-mount the accessory, attach the four adhesive rubber feet included in the BNC-2090A kit to the bottom of the accessory.
2. Connect the BNC-2090A to the DAQ device using the front or rear 68-position connector, shown in Figure 1. Refer to Table 1 to verify that you have the appropriate cable for your DAQ device.

**Table 1.** BNC-2090A Cabling Options

DAQ Device	Required Cable(s)
68-pin PCI, PCIe, PXI, or PXIe M Series*	SHC68-68-EPM or RC68-68
68-pin PCI or PXI E Series	SH68-68-EP or R6868
* Two-connector M Series devices can be cabled to two BNC-2090A accessories with two cables. <b>Note:</b> Refer to the <i>BNC-2090A User Manual</i> for information about other E/M Series device connections.	

If the +5V LED does not light, check the cable connections.

When you have finished using the BNC-2090A, power off any external signals connected to the BNC-2090A before you power off your computer.



**Caution** Do *not* connect input voltages greater than  $42.4 V_{pk}/60$  VDC to the BNC-2090A. The BNC-2090A is not designed for any input voltages greater than  $42.4 V_{pk}/60$  VDC, even if a user-installed voltage divider reduces the voltage to within the input range of the DAQ device. Input voltages greater than  $42.4 V_{pk}/60$  VDC can damage the BNC-2090A, all devices connected to it, and the host computer. Overvoltage can also cause an electric shock hazard for the operator. National Instruments is *not* liable for damage or injury resulting from such misuse.

# Connecting Differential Analog Input Signals

Complete the following steps to measure a differential (DIFF) analog input signal.

1. Connect the BNC cable to one of the AI <0..7> BNC connectors on the front panel.

Do not connect anything to the corresponding AI <8..15> BNC connector below the AI <0..7> BNC connector you use.

2. Move the corresponding SE/DIFF switch to the DIFF position. On the BNC-2090A front panel, a line indicates which SE/DIFF switch corresponds to each AI <0..7> BNC connector.
3. Configure your software to measure this channel differentially.

Figure 3 shows how differential AI signals are routed to the DAQ device.

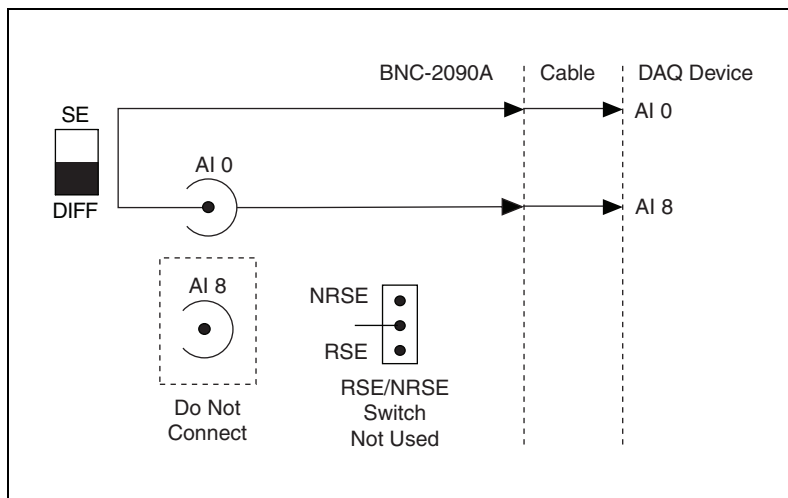

**Figure 3.** Analog Input Differential Mode

# Connecting Single-Ended Analog Input Signals

Complete the following steps to measure a single-ended (SE) analog input signal.

1. Connect the BNC cable to one of the AI <0..15> BNC connectors on the front panel.
2. Move the corresponding SE/DIFF switch to the SE position. On the BNC-2090A front panel, a line indicates which SE/DIFF switch corresponds to each AI <0..15> BNC connector.
3. Move the RSE/NRSE switch to select how the ground signal is routed. All single-ended signals share the one RSE/NRSE switch. For more information about non-referenced single-ended (NRSE) and referenced single-ended (RSE) modes, refer to the *E Series User Manual* or the *M Series User Manual*.
4. Configure your software to measure this channel in RSE or NRSE mode.

Figure 4 shows how single-ended AI signals are routed to the DAQ device.

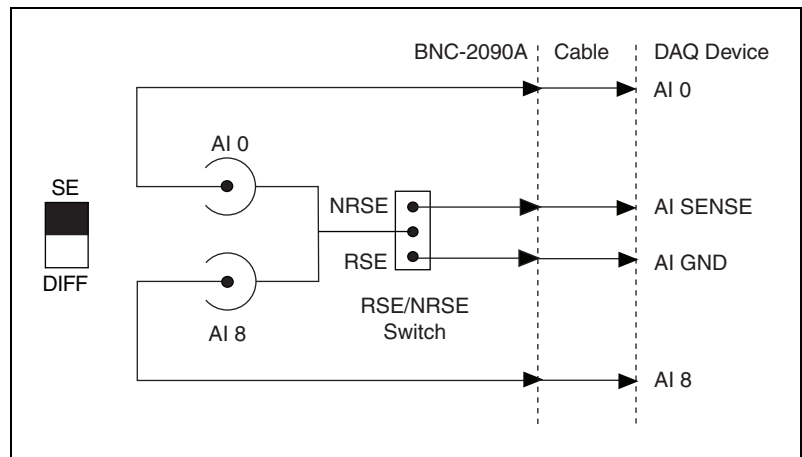

**Figure 4.** Analog Input Single-Ended Mode

# Connecting Analog Output, APFI, and PFI Signals

Use the BNC-2090A BNC connectors on the front panel to connect AO <0..1>, APFI 0, and PFI 0 signals to your DAQ device. Refer to your DAQ device documentation for information on the use of these signals.

Figure 5 shows how AO 0, AO 1, APFI 0, and PFI 0 signals are routed to the DAQ device.

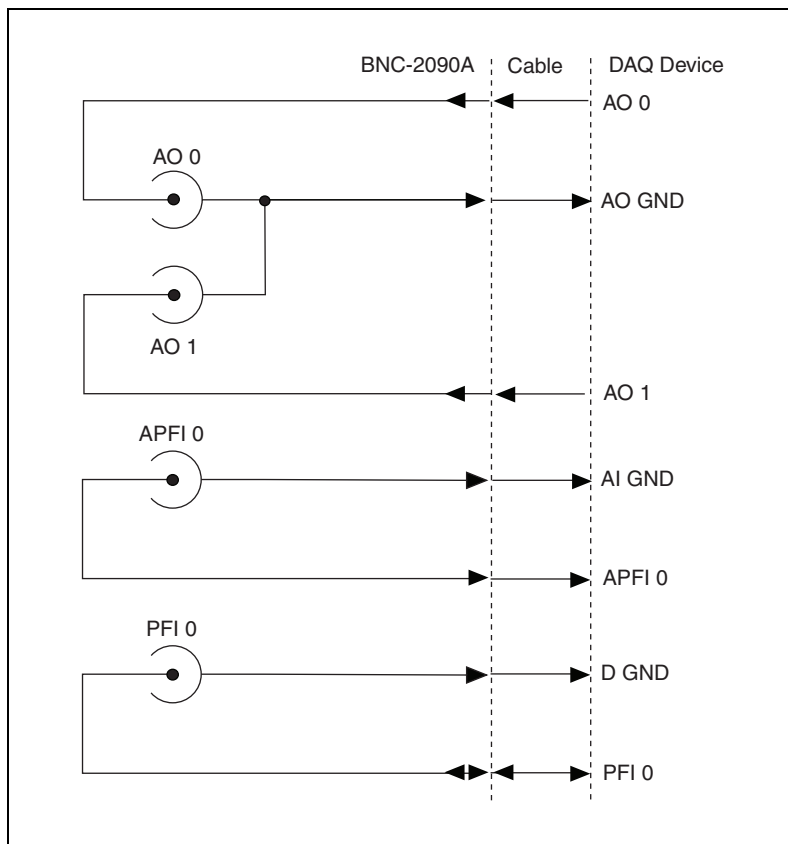

Figure 5. Analog Output, APFI 0, and PFI 0

# Connecting Digital Signals

Use the BNC-2090A spring terminal block on the front panel to connect digital signals to your DAQ device. Refer to your DAQ device documentation for information on the use of these signals.

When connecting signals to the spring terminal blocks, you can use up to 20 AWG wire with the insulation stripped to 0.5 in.

# Using the USER 1 and USER 2 BNC Connectors

The USER 1 and USER 2 BNC connectors allow you to use a BNC connector for a digital or timing I/O signal of your choice. The USER 1 and USER 2 BNC connectors are routed (internal to the BNC-2090A) to the USER1 and USER2 spring terminals, as shown in Figure 6.

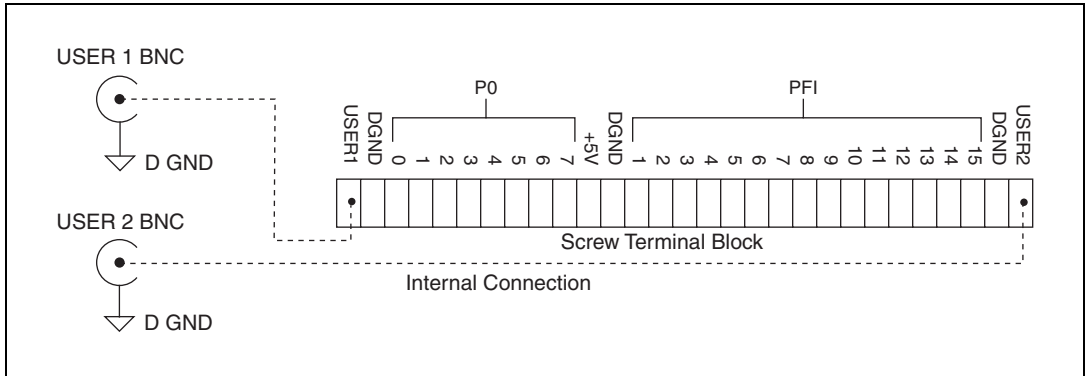

**Figure 6.** USER <1..2> BNC Connections

Figure 7 shows an example of how to use the USER <1..2> BNCs. To access the PFI 5 signal from a BNC, connect USER1 on the spring terminal block to PFI 5 with a wire.

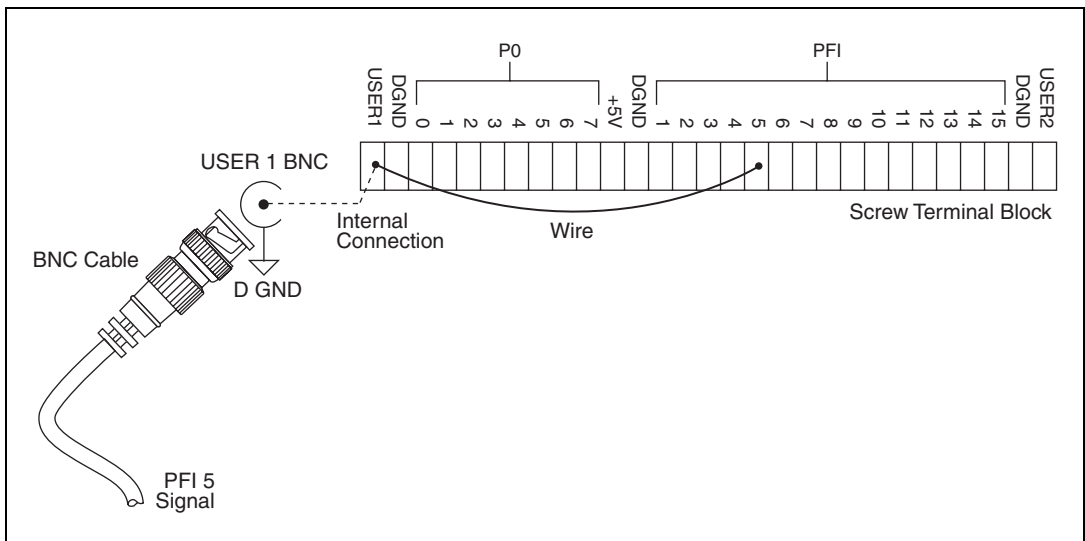

**Figure 7.** Connecting PFI 5 to USER 1 BNC

# Where to Go from Here

---

Refer to the *BNC-2090A User Manual* for information about the following subjects:

- Detailed installation instructions
- In-depth signal information
- Using the BNC-2090A with DAQCard and 100-pin E Series devices and USB Mass Termination M Series devices
- Changing the shield ground jumper setting
- Installing signal conditioning components
- BNC-2090A specifications

You can find the *BNC-2090A User Manual* on [ni.com/manuals](http://ni.com/manuals).