

# IMAQ™

## **IMAQ PCI-1424 User Manual**

*High-Quality Digital Image Acquisition Device for PCI*

## **Worldwide Technical Support and Product Information**

ni.com

### **National Instruments Corporate Headquarters**

11500 North Mopac Expressway Austin, Texas 78759-3504 USA Tel: 512 683 0100

### **Worldwide Offices**

Australia 1800 300 800, Austria 43 0 662 45 79 90 0, Belgium 32 0 2 757 00 20, Brazil 55 11 3262 3599,  
Canada (Calgary) 403 274 9391, Canada (Ottawa) 613 233 5949, Canada (Québec) 450 510 3055,  
Canada (Toronto) 905 785 0085, Canada (Vancouver) 604 685 7530, China 86 21 6555 7838,  
Czech Republic 420 224 235 774, Denmark 45 45 76 26 00, Finland 385 0 9 725 725 11,  
France 33 0 1 48 14 24 24, Germany 49 0 89 741 31 30, India 91 80 51190000, Israel 972 0 3 6393737,  
Italy 39 02 413091, Japan 81 3 5472 2970, Korea 82 02 3451 3400, Malaysia 603 9131 0918,  
Mexico 01 800 010 0793, Netherlands 31 0 348 433 466, New Zealand 0800 553 322, Norway 47 0 66 90 76 60,  
Poland 48 22 3390150, Portugal 351 210 311 210, Russia 7 095 783 68 51, Singapore 65 6226 5886,  
Slovenia 386 3 425 4200, South Africa 27 0 11 805 8197, Spain 34 91 640 0085, Sweden 46 0 8 587 895 00,  
Switzerland 41 56 200 51 51, Taiwan 886 2 2528 7227, Thailand 662 992 7519,  
United Kingdom 44 0 1635 523545

For further support information, refer to the *Technical Support and Professional Services* appendix. To comment on National Instruments documentation, refer to the National Instruments Web site at [ni.com/info](http://ni.com/info) and enter the info code `feedback`.

# Important Information

---

## Warranty

The IMAQ PCI-1424 is warranted against defects in materials and workmanship for a period of one year from the date of shipment, as evidenced by receipts or other documentation. National Instruments will, at its option, repair or replace equipment that proves to be defective during the warranty period. This warranty includes parts and labor.

The media on which you receive National Instruments software are warranted not to fail to execute programming instructions, due to defects in materials and workmanship, for a period of 90 days from date of shipment, as evidenced by receipts or other documentation. National Instruments will, at its option, repair or replace software media that do not execute programming instructions if National Instruments receives notice of such defects during the warranty period. National Instruments does not warrant that the operation of the software shall be uninterrupted or error free.

A Return Material Authorization (RMA) number must be obtained from the factory and clearly marked on the outside of the package before any equipment will be accepted for warranty work. National Instruments will pay the shipping costs of returning to the owner parts which are covered by warranty.

National Instruments believes that the information in this document is accurate. The document has been carefully reviewed for technical accuracy. In the event that technical or typographical errors exist, National Instruments reserves the right to make changes to subsequent editions of this document without prior notice to holders of this edition. The reader should consult National Instruments if errors are suspected. In no event shall National Instruments be liable for any damages arising out of or related to this document or the information contained in it.

EXCEPT AS SPECIFIED HEREIN, NATIONAL INSTRUMENTS MAKES NO WARRANTIES, EXPRESS OR IMPLIED, AND SPECIFICALLY DISCLAIMS ANY WARRANTY OF MERCHANTABILITY OR FITNESS FOR A PARTICULAR PURPOSE. CUSTOMER'S RIGHT TO RECOVER DAMAGES CAUSED BY FAULT OR NEGLIGENCE ON THE PART OF NATIONAL INSTRUMENTS SHALL BE LIMITED TO THE AMOUNT THEREFORE PAID BY THE CUSTOMER. NATIONAL INSTRUMENTS WILL NOT BE LIABLE FOR DAMAGES RESULTING FROM LOSS OF DATA, PROFITS, USE OF PRODUCTS, OR INCIDENTAL OR CONSEQUENTIAL DAMAGES, EVEN IF ADVISED OF THE POSSIBILITY THEREOF. This limitation of the liability of National Instruments will apply regardless of the form of action, whether in contract or tort, including negligence. Any action against National Instruments must be brought within one year after the cause of action accrues. National Instruments shall not be liable for any delay in performance due to causes beyond its reasonable control. The warranty provided herein does not cover damages, defects, malfunctions, or service failures caused by owner's failure to follow the National Instruments installation, operation, or maintenance instructions; owner's modification of the product; owner's abuse, misuse, or negligent acts; and power failure or surges, fire, flood, accident, actions of third parties, or other events outside reasonable control.

## Copyright

Under the copyright laws, this publication may not be reproduced or transmitted in any form, electronic or mechanical, including photocopying, recording, storing in an information retrieval system, or translating, in whole or in part, without the prior written consent of National Instruments Corporation.

## Trademarks

CVI™, IMAQ™, LabVIEW™, Measurement Studio™, National Instruments™, National Instruments Alliance Partner™, NI™, ni.com™, NI-DAQ™, NI-IMAQ™, and RTSI™ are trademarks of National Instruments Corporation.

Product and company names mentioned herein are trademarks or trade names of their respective companies.

Members of the National Instruments Alliance Partner Program are business entities independent from National Instruments and have no agency, partnership, or joint-venture relationship with National Instruments.

## Patents

For patents covering National Instruments products, refer to the appropriate location: **Help»Patents** in your software, the `patents.txt` file on your CD, or [ni.com/patents](http://ni.com/patents).

## WARNING REGARDING USE OF NATIONAL INSTRUMENTS PRODUCTS

(1) NATIONAL INSTRUMENTS PRODUCTS ARE NOT DESIGNED WITH COMPONENTS AND TESTING FOR A LEVEL OF RELIABILITY SUITABLE FOR USE IN OR IN CONNECTION WITH SURGICAL IMPLANTS OR AS CRITICAL COMPONENTS IN ANY LIFE SUPPORT SYSTEMS WHOSE FAILURE TO PERFORM CAN REASONABLY BE EXPECTED TO CAUSE SIGNIFICANT INJURY TO A HUMAN.

(2) IN ANY APPLICATION, INCLUDING THE ABOVE, RELIABILITY OF OPERATION OF THE SOFTWARE PRODUCTS CAN BE IMPAIRED BY ADVERSE FACTORS, INCLUDING BUT NOT LIMITED TO FLUCTUATIONS IN ELECTRICAL POWER SUPPLY, COMPUTER HARDWARE MALFUNCTIONS, COMPUTER OPERATING SYSTEM SOFTWARE FITNESS, FITNESS OF COMPILERS AND DEVELOPMENT SOFTWARE USED TO DEVELOP AN APPLICATION, INSTALLATION ERRORS, SOFTWARE AND HARDWARE COMPATIBILITY PROBLEMS, MALFUNCTIONS OR FAILURES OF ELECTRONIC MONITORING OR CONTROL DEVICES, TRANSIENT FAILURES OF ELECTRONIC SYSTEMS (HARDWARE AND/OR SOFTWARE), UNANTICIPATED USES OR MISUSES, OR ERRORS ON THE PART OF THE USER OR APPLICATIONS DESIGNER (ADVERSE FACTORS SUCH AS THESE ARE HEREAFTER COLLECTIVELY TERMED "SYSTEM FAILURES"). ANY APPLICATION WHERE A SYSTEM FAILURE WOULD CREATE A RISK OF HARM TO PROPERTY OR PERSONS (INCLUDING THE RISK OF BODILY INJURY AND DEATH) SHOULD NOT BE RELIANT SOLELY UPON ONE FORM OF ELECTRONIC SYSTEM DUE TO THE RISK OF SYSTEM FAILURE. TO AVOID DAMAGE, INJURY, OR DEATH, THE USER OR APPLICATION DESIGNER MUST TAKE REASONABLY PRUDENT STEPS TO PROTECT AGAINST SYSTEM FAILURES, INCLUDING BUT NOT LIMITED TO BACK-UP OR SHUT DOWN MECHANISMS. BECAUSE EACH END-USER SYSTEM IS CUSTOMIZED AND DIFFERS FROM NATIONAL INSTRUMENTS' TESTING PLATFORMS AND BECAUSE A USER OR APPLICATION DESIGNER MAY USE NATIONAL INSTRUMENTS PRODUCTS IN COMBINATION WITH OTHER PRODUCTS IN A MANNER NOT EVALUATED OR CONTEMPLATED BY NATIONAL INSTRUMENTS, THE USER OR APPLICATION DESIGNER IS ULTIMATELY RESPONSIBLE FOR VERIFYING AND VALIDATING THE SUITABILITY OF NATIONAL INSTRUMENTS PRODUCTS WHENEVER NATIONAL INSTRUMENTS PRODUCTS ARE INCORPORATED IN A SYSTEM OR APPLICATION, INCLUDING, WITHOUT LIMITATION, THE APPROPRIATE DESIGN, PROCESS AND SAFETY LEVEL OF SUCH SYSTEM OR APPLICATION.

# Compliance

---

## Compliance with FCC/Canada Radio Frequency Interference Regulations

### Determining FCC Class

The Federal Communications Commission (FCC) has rules to protect wireless communications from interference. The FCC places digital electronics into two classes. These classes are known as Class A (for use in industrial-commercial locations only) or Class B (for use in residential or commercial locations). All National Instruments (NI) products are FCC Class A products.

Depending on where it is operated, this Class A product could be subject to restrictions in the FCC rules. (In Canada, the Department of Communications (DOC), of Industry Canada, regulates wireless interference in much the same way.) Digital electronics emit weak signals during normal operation that can affect radio, television, or other wireless products.

All Class A products display a simple warning statement of one paragraph in length regarding interference and undesired operation. The FCC rules have restrictions regarding the locations where FCC Class A products can be operated.

Consult the FCC Web site at [www.fcc.gov](http://www.fcc.gov) for more information.

### FCC/DOC Warnings

This equipment generates and uses radio frequency energy and, if not installed and used in strict accordance with the instructions in this manual and the CE marking Declaration of Conformity\*, may cause interference to radio and television reception. Classification requirements are the same for the Federal Communications Commission (FCC) and the Canadian Department of Communications (DOC).

Changes or modifications not expressly approved by NI could void the user's authority to operate the equipment under the FCC Rules.

### Class A

#### Federal Communications Commission

This equipment has been tested and found to comply with the limits for a Class A digital device, pursuant to part 15 of the FCC Rules. These limits are designed to provide reasonable protection against harmful interference when the equipment is operated in a commercial environment. This equipment generates, uses, and can radiate radio frequency energy and, if not installed and used in accordance with the instruction manual, may cause harmful interference to radio communications. Operation of this equipment in a residential area is likely to cause harmful interference in which case the user is required to correct the interference at their own expense.

#### Canadian Department of Communications

This Class A digital apparatus meets all requirements of the Canadian Interference-Causing Equipment Regulations.

Cet appareil numérique de la classe A respecte toutes les exigences du Règlement sur le matériel brouilleur du Canada.

### Compliance with EU Directives

Users in the European Union (EU) should refer to the Declaration of Conformity (DoC) for information\* pertaining to the CE marking. Refer to the Declaration of Conformity (DoC) for this product for any additional regulatory compliance information. To obtain the DoC for this product, visit [ni.com/certification](http://ni.com/certification), search by model number or product line, and click the appropriate link in the Certification column.

\* The CE marking Declaration of Conformity contains important supplementary information and instructions for the user or installer.

# Conventions

---

The following conventions are used in this manual:

» The » symbol leads you through nested menu items and dialog box options to a final action. The sequence **File»Page Setup»Options** directs you to pull down the **File** menu, select the **Page Setup** item, and select **Options** from the last dialog box.



This icon denotes a note, which alerts you to important information.



This icon denotes a caution, which advises you of precautions to take to avoid injury, data loss, or a system crash. When this symbol is marked on a product, refer to the *Safety Information* section of Chapter 2, *Configuration and Installation*, for information about precautions to take.



When symbol is marked on a product, it denotes a warning advising you to take precautions to avoid electrical shock.



When symbol is marked on a product it, denotes a component that may be hot. Touching this component may result in bodily injury.

**bold**

Bold text denotes items that you must select or click in the software, such as menu items and dialog box options. Bold text also denotes parameter names.

*italic*

Italic text denotes variables, emphasis, a cross reference, or an introduction to a key concept. This font also denotes text that is a placeholder for a word or value that you must supply.

monospace

Text in this font denotes text or characters that you should enter from the keyboard, sections of code, programming examples, and syntax examples. This font is also used for the proper names of disk drives, paths, directories, programs, subprograms, subroutines, device names, functions, operations, variables, filenames, and extensions.

# Contents

---

## Chapter 1

### Introduction

About the IMAQ PCI-1424 .....	1-1
Software Overview .....	1-2
NI-IMAQ Driver Software .....	1-2
National Instruments Application Software .....	1-3
Vision Builder for Automated Inspection .....	1-3
Vision Development Module .....	1-3
Integration with DAQ .....	1-4
Vision and Motion .....	1-4

## Chapter 2

### Configuration and Installation

What You Need to Get Started .....	2-1
Optional Equipment .....	2-2
Unpacking .....	2-2
Safety Information .....	2-3
Installation .....	2-5

## Chapter 3

### Hardware Overview

Functional Overview .....	3-1
Signaling .....	3-2
LUTs .....	3-2
Multiple-Tap Data Formatter .....	3-3
SDRAM .....	3-3
RS-232 Serial Interface .....	3-3
Trigger Control and Mapping Circuitry .....	3-3
High-Speed Timing .....	3-4
Acquisition and ROI .....	3-4
Scatter-Gather DMA Controllers .....	3-4
Device Configuration NVRAM .....	3-4
Start Conditions .....	3-4
Acquisition Window Control .....	3-5

## **Chapter 4**

### **Signal Connections**

I/O Connector .....	4-1
Signal Description .....	4-3

### **Appendix A Specifications**

### **Appendix B Technical Support and Professional Services**

### **Glossary**

### **Index**

---

# Introduction

This chapter describes the IMAQ PCI-1424 device and describes your software programming choices.

## About the IMAQ PCI-1424

---

The PCI-1424 is a highly flexible, monochrome and color, PCI-based image acquisition (IMAQ) device that supports a diverse range of digital cameras from many camera companies. The PCI-1424 acquires digital images in real time and can store these images in onboard frame memory, or transfer these images directly to system memory. The device can capture up to 32 bits of data at a time at clock speeds up to 50 MHz.<sup>1</sup>

The PCI-1424 is simple to configure so that you can easily install the device and begin acquiring images. The PCI-1424 ships with NI-IMAQ, the National Instruments complete IMAQ driver software you can use to directly control the PCI-1424 and other National Instruments IMAQ hardware products. Using NI-IMAQ, you can quickly and easily start your applications without having to program the device at the register level.

Featuring a high-speed data flow path, the PCI-1424 is ideal for both industrial and scientific environments. As a standalone device, the PCI-1424 supports up to 32 bits of differential or TTL level video data, four general purpose control lines that can be configured to generate precise timing signals to control digital camera acquisition, and four external input/output (I/O) lines that you can use as triggers or as high-speed digital I/O lines. If you require more advanced triggering or digital I/O lines (either digital or analog), you can use the PCI-1424 and NI-IMAQ with the National Instruments data acquisition (DAQ) product line.

A common problem with image acquisition devices is that you cannot easily synchronize several functions to a common *trigger* or timing event. The PCI-1424 uses its Real-Time System Integration (RTSI) bus to solve this problem. The RTSI bus consists of the National Instruments RTSI bus interface and ribbon cable to route additional timing and trigger signals

---

<sup>1</sup> Early versions of the PCI-1424 may not support acquisitions at 50 MHz. For the exact maximum acquisition clock rate of your PCI-1424, refer to the **Maximum Clock Rate** indicator in Measurement & Automation Explorer.

between the PCI-1424 and up to four National Instruments DAQ or IMAQ devices in your computer. The RTSI bus can even synchronize multiple IMAQ hardware captures.

Detailed specifications of the PCI-1424 are in Appendix A, [Specifications](#).

## Software Overview

---

Programming the PCI-1424 device requires the NI-IMAQ driver software for controlling the hardware and one of the following application software packages for image processing:

- **Vision Builder for Automated Inspection (AI)**—for configuring solutions to common inspection tasks
- **National Instruments Vision Development Module**—for more customized control over hardware and algorithms

The following sections provide an overview of the driver software and the application software. For detailed information about individual software packages, refer to the documentation specific to the package.

### NI-IMAQ Driver Software

The NI-IMAQ driver software ships with the PCI-1424 device. NI-IMAQ has an extensive library of functions you can call from your application programming environment, such as routines for video configuration, image acquisition (continuous and single-shot), [memory buffer](#) allocation, trigger control, and device configuration.

NI-IMAQ performs all functions required for acquiring and saving images but does not perform image analysis. For image analysis functionality, refer to the [National Instruments Application Software](#) section of this chapter.

NI-IMAQ is also the interface path between LabVIEW, LabWindows™/CVI™, or a text-based programming environment and the IMAQ device. The NI-IMAQ software kit includes a series of libraries for image acquisition for LabVIEW, LabWindows/CVI, and Measurement Studio, which contains libraries for Visual Basic.

For maximum flexibility and performance, NI-IMAQ features both high-level and low-level functions. Examples of high-level functions include the sequences to acquire images in multi-buffer, single-shot, or continuous mode. An example of a low-level function is configuring an image sequence, since it requires advanced understanding of the IMAQ device and image acquisition.

NI-IMAQ handles many of the complex issues between the computer and the IMAQ device, such as programming interrupts and camera control.

## National Instruments Application Software

### Vision Builder for Automated Inspection

NI Vision Builder for Automated Inspection (AI) is configurable machine vision software that you can use to prototype, benchmark, and deploy applications. Vision Builder AI does not require programming, but is scalable to powerful programming environments.

Vision Builder AI allows you to easily configure and benchmark a sequence of visual inspection steps, as well as deploy the visual inspection system for automated inspection. With Vision Builder AI you can perform powerful visual inspection tasks and make decisions based on the results of individual tasks. With Vision Builder AI, you can migrate your configured inspection to LabVIEW, extending the capabilities of your applications if necessary.

Vision Builder AI is available for LabVIEW, LabWindows/CVI, and Measurement Studio, which includes support for Visual Basic.

### Vision Development Module

The Vision Development Module is an image acquisition, processing, and analysis library of more than 270 functions for grayscale, color, and binary image display, image processing, pattern matching, particle analysis, gauging, and measurement.

For unique image processing, you can use the Vision Development Module functions individually or in combination. With the Vision Development Module you can acquire, display, manipulate, and store images, as well as perform image analysis, processing, and interpretation. Using the Vision Development Module, imaging novices and experts can program the most basic or complicated image applications without knowledge of particular algorithm implementations.

NI Vision Assistant is included with the Vision Development Module. Vision Assistant is an interactive prototyping tool for machine vision and scientific imaging developers. With Vision Assistant, you can prototype vision applications quickly and test how various vision image processing functions work.

Vision Assistant generates a builder file, which is a text description containing a recipe of the machine vision and image processing functions. This builder file provides a guide you can use for developing applications into any development environment, such as LabWindows/CVI or Visual Basic, using the Vision Assistant machine vision and image processing libraries. Using the LabVIEW VI creation wizard, Vision Assistant can create LabVIEW VI diagrams that perform the prototype you created in Vision Assistant. Using LabVIEW, you can add functionality to this generated VI.

## Integration with DAQ

Platforms that support NI-IMAQ also support NI-DAQ and a variety of National Instruments DAQ devices. This allows integration between IMAQ devices and National Instruments DAQ products.

## Vision and Motion

With National Instruments IMAQ hardware and Vision Assistant pattern matching software, you can quickly and accurately locate objects that vary in size, orientation, focus, and illumination. Use National Instruments high-performance stepper and servo motion control products with pattern matching software in inspection and guidance applications, such as locating alignment markers on semiconductor wafers, guiding robotic arms, inspecting the quality of manufactured parts, and locating cells.

---

# Configuration and Installation

This chapter lists what you need to get started acquiring images with your IMAQ PCI-1424 device; describes optional equipment and custom cables; and explains how to unpack, configure, and install your IMAQ device.

## What You Need to Get Started

---

To set up and use your PCI-1424, you will need the following:

- PCI-1424 device
- NI-IMAQ for Windows 2000/NT/XP
- Optional software packages and documentation:
  - NI Vision Builder for Automated Inspection
  - NI Vision Assistant
  - LabVIEW
  - LabWindows/CVI
  - Measurement Studio
- IMAQ D100 series camera cables, depending on your camera
- IMAQ D2504 video cable (optional—for access to trigger lines)
- A video camera or other video source
- Pentium-based PCI computer running Windows 2000/NT/XP

## Optional Equipment

---

National Instruments offers a variety of products for use with your PCI-1424, including the following cables and other National Instruments products:

- Cables to connect your digital camera to the PCI-1424
- A four-pod BNC cable, which routes trigger signals to a BNC connector block (IMAQ D2504)
- IMAQ memory modules to increase PCI-1424 onboard memory
- RTSI bus cables for connecting the PCI-1424 to other IMAQ, DAQ, or motion control hardware
- Other National Instruments DAQ devices for enhanced triggering, timing, or input/output

For specific information about these products, refer to the National Instruments catalog, visit [ni.com](http://ni.com) or call the office nearest you.

## Unpacking

---

The PCI-1424 device ships in an antistatic package to prevent electrostatic discharge from damaging device components. To avoid such damage in handling the device, take the following precautions:

- Ground yourself using a grounding strap or by holding a grounded object, such as your computer chassis.
- Touch the antistatic package to a metal part of your computer chassis before removing the device from the package.



**Caution** *Never* touch the exposed pins of connectors.

- Remove the device from the package and inspect it for loose components or any other signs of damage. Notify National Instruments if the device appears damaged in any way. Do *not* install a damaged device in your computer.

# Safety Information

---



**Caution** The following paragraphs contain important safety information you *must* follow when installing and operating the device.

Do *not* operate the module in a manner not specified in this document. Misuse of the module can result in a hazard. You can compromise the safety protection built into the module if the module is damaged in any way. If the module is damaged, return it to National Instruments (NI) for repair.

Do *not* substitute parts or modify the module except as described in this document. Use the module only with the chassis, modules, accessories, and cables specified in the installation instructions. You must have all covers and filler panels installed during operation of the module.

Do *not* operate the module in an explosive atmosphere or where there may be flammable gases or fumes. If you must operate the module in such an environment, it must be in a suitably rated enclosure.

If you need to clean the module, use a soft, nonmetallic brush. Make sure that the module is completely dry and free from contaminants before returning it to service.

Operate the module only at or below Pollution Degree 2. Pollution is foreign matter in a solid, liquid, or gaseous state that can reduce dielectric strength or surface resistivity. The following is a description of pollution degrees:

- Pollution Degree 1 means no pollution or only dry, nonconductive pollution occurs. The pollution has no influence.
- Pollution Degree 2 means that only nonconductive pollution occurs in most cases. Occasionally, however, a temporary conductivity caused by condensation must be expected.
- Pollution Degree 3 means that conductive pollution occurs, or dry, nonconductive pollution occurs that becomes conductive due to condensation.

You *must* insulate signal connections for the maximum voltage for which the module is rated. Do *not* exceed the maximum ratings for the module. Do not install wiring while the module is live with electrical signals. Do not remove or add connector blocks when power is connected to the system.

Avoid contact between your body and the connector block signal when hot swapping modules. Remove power from signal lines before connecting them to or disconnecting them from the module.

Operate the module at or below *installation category*<sup>1</sup> marked on the hardware label. Measurement circuits are subjected to *working voltages*<sup>2</sup> and transient stresses (overvoltage) from the circuit to which they are connected during measurement or test. Installation categories establish standard impulse withstand voltage levels that commonly occur in electrical distribution systems. The following is a description of installation categories:

- Installation Category I is for measurements performed on circuits not directly connected to the electrical distribution system referred to as MAINS<sup>3</sup> voltage. This category is for measurements of voltages from specially protected secondary circuits. Such voltage measurements include signal levels, special equipment, limited-energy parts of equipment, circuits powered by regulated low-voltage sources, and electronics.
- Installation Category II is for measurements performed on circuits directly connected to the electrical distribution system. This category refers to local-level electrical distribution, such as that provided by a standard wall outlet (for example, 115 AC voltage for U.S. or 230 AC voltage for Europe). Examples of Installation Category II are measurements performed on household appliances, portable tools, and similar modules.
- Installation Category III is for measurements performed in the building installation at the distribution level. This category refers to measurements on hard-wired equipment such as equipment in fixed installations, distribution boards, and circuit breakers. Other examples are wiring, including cables, bus bars, junction boxes, switches, socket outlets in the fixed installation, and stationary motors with permanent connections to fixed installations.
- Installation Category IV is for measurements performed at the primary electrical supply installation (<1,000 V). Examples include electricity meters and measurements on primary overcurrent protection devices and on ripple control units.

---

<sup>1</sup> Installation categories, also referred to as measurement categories, are defined in electrical safety standard IEC 61010-1.

<sup>2</sup> Working voltage is the highest rms value of an AC or DC voltage that can occur across any particular insulation.

<sup>3</sup> MAINS is defined as a hazardous live electrical supply system that powers equipment. Suitably rated measuring circuits may be connected to the MAINS for measuring purposes.

# Installation

---

Install the PCI-1424 in any available PCI expansion slot in your computer. To achieve the best noise performance, leave as much room as possible between the PCI-1424 and other devices and hardware.

Complete the following steps to install the PCI-1424.

1. Verify that the NI-IMAQ driver software is installed on your computer.
2. Power off and unplug your computer.



**Caution** To protect both yourself and the computer from electrical hazards, the computer should remain off and unplugged until you finish installing the PCI-1424 device.

3. Remove the computer cover. Make sure there are no lit LEDs on the motherboard. If any are lit, wait until they go out before continuing installation.
4. Touch the metal part of the power supply case inside the computer to discharge any static electricity that might be on your clothes or body.
5. Locate the metal bracket that covers the cut-out in the back panel of the chassis for the slot you have selected. Remove and save the bracket-retaining screw and the bracket cover.
6. Line up the PCI-1424 card-edge connector with the expansion slot receptacle. Using slow, evenly distributed pressure, press the PCI-1424 straight down until it seats in the expansion slot.
7. Reinstall the bracket-retaining screw to secure the PCI-1424 to the back panel rail.
8. Visually verify the installation.
9. Replace the computer cover, and plug the computer in.

---

# Hardware Overview

This chapter presents an overview of the hardware functions on your IMAQ PCI-1424 device and explains the operation of each functional unit making up the PCI-1424.

## Functional Overview

---

The PCI-1424 features a flexible, high-speed data path optimized for the reception and formatting of video data from digital monochrome and color cameras.

The block diagram in Figure 3-1 illustrates the key functional components of the PCI-1424.

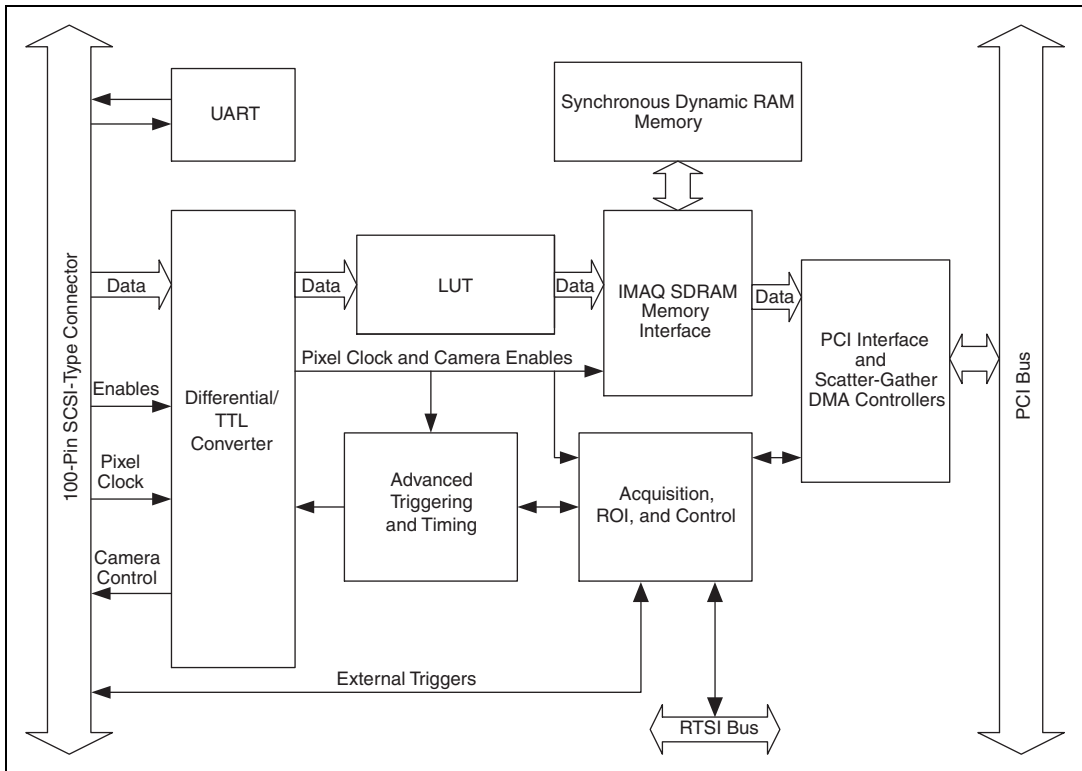

Figure 3-1. PCI-1424 Block Diagram

## Signaling

The PCI-1424 is available in two different versions. The RS-422/TTL version can drive and receive RS-422 and TTL-level signals. NI-IMAQ can control these signals independently for data, control, and enable lines on the 100-pin connector. The LVDS/TTL version, also known as EIA-644, can drive and receive LVDS- and TTL-level signals. Benefits of LVDS include less power consumption, longer cable lengths, less noise, and higher clock rates.

## LUTs

You can configure the PCI-1424 to use either four 8-bit or two 10-bit to 16-bit lookup tables (LUTs) to perform LUT operations such as contrast enhancement, data inversion, *gamma* manipulation, or other nonlinear transfer functions.

## Multiple-Tap Data Formatter

Many of the digital cameras on the market send multiple channels, or *taps*, of data over the cable simultaneously to increase the frame rate of the camera. However, the data in each tap may not be transferred in the traditional top-left to bottom-right direction. Also, the taps may not transfer data in similar directions.

The multiple tap data formatting circuitry on the PCI-1424 can reorder the data from up to four 8-bit taps. The data from each tap can be independently scanned either from left-to-right or right-to-left and top-to-bottom or bottom-to-top.

## SDRAM

The PCI-1424 comes with 16 MB of onboard high-speed synchronous dynamic RAM (SDRAM). You can purchase additional SO-DIMM memory upgrades from National Instruments. SO-DIMM upgrades are available in 64 MB and 128 MB densities.

The PCI-1424 can also use the onboard RAM as a first-in first-out (FIFO) buffer so that in some instances, the PCI-1424 can capture images larger than the amount of RAM on the device.

## RS-232 Serial Interface

You can use the RS-232 serial interface on the 100-pin SCSI-type connector to control digital cameras that also have a serial interface for camera control and configuration. The serial interface is configurable, allowing you to customize it to your camera requirements.

## Trigger Control and Mapping Circuitry

The *trigger control and mapping circuitry* routes, monitors, and drives the external and RTSI bus trigger lines. You can configure each of these lines to start an acquisition on a rising or falling edge. In addition, you can drive each line asserted or unasserted, similar to a digital I/O line. You can also map pulses from the high-speed timing circuitry or many of the PCI-1424 status signals to these trigger lines. There are four external and seven RTSI bus triggers. You can program each of these triggers in polarity and direction.

## High-Speed Timing

The high-speed timing circuitry on the PCI-1424, built from high-speed counters, allows you to specify or generate precise, real-time control signals. You can map the output of this circuitry to a trigger line to provide accurate pulses and pulse trains.

## Acquisition and ROI

The acquisition and region-of-interest (ROI) circuitry monitors the incoming video signals and routes the active *pixels* to the multiple-tap data formatter and SDRAM memory. In an ROI acquisition, you select an area within the *acquisition window* to transfer to the PCI bus.

## Scatter-Gather DMA Controllers

The PCI-1424 uses three independent onboard direct memory access (DMA) controllers. The DMA controllers transfer data between the onboard SDRAM memory buffers and the PCI bus. Each of these controllers supports *scatter-gather DMA*, which allows the DMA controller to reconfigure on-the-fly. Thus, the PCI-1424 can perform continuous image transfers directly to either contiguous or fragmented memory buffers.

## Device Configuration NVRAM

The PCI-1424 contains onboard nonvolatile RAM (*NVRAM*) that configures all registers on power-up.

## Start Conditions

The PCI-1424 can start acquisitions in a variety of conditions:

- Software control—The PCI-1424 supports software control of acquisition start. You can configure the PCI-1424 to capture a fixed number of *fields* or *frames*. This configuration is useful for capturing a single frame or a sequence of frames.
- Trigger control—You can start an acquisition by enabling external or RTSI bus trigger lines. Each of these inputs can start a video acquisition on a rising or falling edge.

- Delayed acquisition—You can use either software or triggers to start acquisitions instantaneously or after skipping a specific period of time. You can use delayed acquisition for posttrigger applications.
- Frame/field selection—With an *interlaced* camera and the PCI-1424 in frame mode, you can program the PCI-1424 to start an acquisition on any odd or even field.

## Acquisition Window Control

You can configure numerous parameters on the PCI-1424 to control the video acquisition window. A brief description of each parameter follows:

- Acquisition window—The PCI-1424 allows the user to specify a particular region of active pixels and active lines within the incoming video data. The *active pixel region* selects the starting pixel and number of pixels to be acquired relative to the assertion edge of the horizontal (or line) enable signal from the camera. The *active line region* selects the starting line and number of lines to be acquired relative to the assertion edge of the vertical (or frame) enable signal.
- Region of interest—The PCI-1424 uses a second level of active pixel and active line regions for selecting a region of interest. When you disable the region-of-interest circuitry, the device stores the entire acquisition window in onboard or system memory. However, when you enable the region-of-interest circuitry, the device acquires only a selected subset of the image frame.
- Interlaced video—The PCI-1424 supports both interlaced and non-interlaced, or progressive scan, digital video signals. In interlaced mode, the PCI-1424 combines the odd and even fields into one contiguous frame for analysis. In non-interlaced mode, each field is treated as an independent frame.

---

# Signal Connections

This chapter describes cable connections for the IMAQ PCI-1424 device.

## I/O Connector

---

The PCI-1424 100-pin SCSI-type connector connects to all digital video data inputs, digital enable inputs, camera control outputs, RS-232 serial interface, and the *external trigger* signals. To access these connections, you can build your own custom cable or use one of the optional cables from National Instruments.



**Note** Refer to the National Instruments Web site, [ni.com/imaq](http://ni.com/imaq), for the latest information on optional cables and the cameras they support.

Figure 4-1 shows the pinout of the 100-pin SCSI-type connector.

Data0+	1	51	Data16+
Data0-	2	52	Data16-
Data1+	3	53	Data17+
Data1-	4	54	Data17-
Data2+	5	55	Data18+
Data2-	6	56	Data18-
Data3+	7	57	Data19+
Data3-	8	58	Data19-
Data4+	9	59	Data20+
Data4-	10	60	Data20-
Data5+	11	61	Data21+
Data5-	12	62	Data21-
Data6+	13	63	Data22+
Data6-	14	64	Data22-
Data7+	15	65	Data23+
Data7-	16	66	Data23-
Data8+	17	67	Data24+
Data8-	18	68	Data24-
Data9+	19	69	Data25+
Data9-	20	70	Data25-
Data10+	21	71	Data26+
Data10-	22	72	Data26-
Data11+	23	73	Data27+
Data11-	24	74	Data27-
Data12+	25	75	Data28+
Data12-	26	76	Data28-
Data13+	27	77	Data29+
Data13-	28	78	Data29-
Data14+	29	79	Data30+
Data14-	30	80	Data30-
Data15+	31	81	Data31+
Data15-	32	82	Data31-
Control0+	33	83	RI (RS-232)
Control0-	34	84	DTR (RS-232)
Control1+	35	85	DSR (RS-232)
Control1-	36	86	RTS (RS-232)
Control2+	37	87	CTS (RS-232)
Control2-	38	88	DCD (RS-232)
Control3+	39	89	Reserved
Control3-	40	90	Reserved
EnableA+	41	91	Reserved
EnableA-	42	92	Reserved
EnableB+	43	93	SOUT (RS-232)
EnableB-	44	94	SIN (RS-232)
EnableC+	45	95	External Trigger0
EnableC-	46	96	External Trigger1
EnableD+	47	97	External Trigger2
EnableD-	48	98	External Trigger3
Pixel Clock +	49	99	GND
Pixel Clock -	50	100	GND

Figure 4-1. PCI-1424 Pin Assignments

# Signal Description

Table 4-1 describes each signal connection on the 100-pin SCSI connector.

**Table 4-1.** I/O Connector Signals

Signal Name	Description
Data<31..0>±	Data<31..0>± allows you to connect data up to 32 bits wide in either TTL or differential format to the PCI-1424.
Control<3..0>±	You can use the control lines on the PCI-1424 to control digital camera features and timing information. Either TTL or differential signals can be generated on these lines to perform such functions as generating integration or shutter pulses to the digital cameras.
Enable<D..A>±	The PCI-1424 can receive any combination of up to four enable signals. These signals can be either TTL or differential. Examples of camera signals which might be connected to these pins are frame enable, line enable, even enable and odd enable. If your camera has a separate field signal, that line should be connected to Enable C.
SOUT	Serial Data Out is used for RS-232 connections.
SIN	Serial Data In is used for RS-232 connections.
RI	Ring Indicator is used for RS-232 connections.
DTR	Data Terminal Ready is used for RS-232 connections.
DSR	Data Set Ready is used for RS-232 connections.
RTS	Request to Send is used for RS-232 connections.
CTS	Clear to Send is used for RS-232 connections.
DCD	Data Carrier Detect is used for RS-232 connections.
External Trigger<3..0>	External Trigger<3..0> are TTL I/O lines used to start an acquisition or output to control external events. You can program the triggers to be rising or falling edge sensitive. You can also program the triggers to be programmatically asserted or unasserted similar to the function of a digital I/O line or to contain internal status signals (by using the onboard events) or specific pulse widths.
Pixel Clock±	The PCI-1424 uses the Pixel Clock input as a reference clock to latch the incoming video data in either TTL or differential format.
GND	GND is a direct connection to digital ground on the PCI-1424.

# Specifications

This appendix lists the specifications of the IMAQ PCI-1424 device. These specifications are typical at 25 °C, unless otherwise stated.

## External Connections

Number of external trigger I/O lines..... 4

### Trigger input

Voltage range ..... 0 to 5 V (TTL)  
 Input high voltage ..... 2.0 V  
 Input low voltage ..... 0.8 V  
 Polarity ..... Programmable,  
 active-high or active-low

### Trigger output

Voltage range ..... 0 to 5 V (TTL)  
 Output high voltage ..... 2.4 V at 15 mA source  
 Output low voltage ..... 0.55 V at 10 mA sink  
 Polarity ..... Programmable,  
 active-high or active-low

Power-on state ..... Input (high-impedance)  
 10 K $\Omega$  pull-up to 5 V

## PCI-1424 RS-422/TTL

### Pixel clock

Signaling type ..... Configurable, RS-422 or TTL  
 Polarity ..... Configurable, rising or falling  
 edge

### Enable

Signal type ..... Configurable, RS-422 or TTL  
 Polarity ..... Configurable, active-high or  
 active-low

Control

Signal type .....Configurable, RS-422 or TTL  
Polarity .....Configurable, active-high or active-low

Minimum control signal pulse width.....20 ns

Video data signal type .....Configurable, RS-422 or TTL

## PCI-1424 LVDS/TTL

Pixel clock

Signaling type .....Configurable, LVDS or TTL  
Polarity .....Configurable, rising or falling edge

Enable

Signal type .....Configurable, LVDS or TTL  
Polarity .....Configurable, active-high or active-low

Control

Signal type .....Configurable, LVDS or TTL  
Polarity .....Configurable, active-high or active-low

Minimum control signal pulse width.....20 ns

Video data signal type .....Configurable, LVDS or TTL

## Memory

Onboard memory .....16 MB SDRAM

LUTs .....Four 8-bit; two 10-bit to 16-bit



**Note** SO-DIMM memory upgrades are available in 64 MB and 128 MB densities.

## Clocks

Pixel clock frequency range.....20 KHz to 50 MHz

## PCI Interface

Theoretical max PCI bandwidth ..... 133 MB/s

## Serial Interface

Signaling standard..... RS-232

Baud rates supported ..... Configurable; 300, 600, 1200, 1800, 2000, 2400, 3600, 4800, 7200, or 9600 bps; 19.2, 38.4, or 56 kbps

Data bits ..... Configurable; 5, 6, 7, or 8 bits

Parity ..... Configurable; odd, even, or disabled

Stop bit ..... Configurable; enabled or disabled

Data transmit ready polarity ..... Configurable; active-high or active-low

Ready-to-send polarity ..... Configurable; active-high or active-low

## Power Requirements

Voltage ..... + 5 V (2.135 A)  
 +12 V (250 mA)  
 -12 V (100 mA)

## Physical

Dimensions..... 106.68 cm × 312 cm  
 (4.2 in. × 12.283 in.)

Weight..... 1.1 kg (0.5 lb)

## Environment

The PCI-1424 device is intended for indoor use only.

Operating temperature..... 0 to 55 °C

Storage temperature ..... -20 to 70 °C

Maximum altitude ..... 2,000 m

Pollution Degree .....	2
Relative humidity .....	5% to 90%, noncondensing

## Safety

The IMAQ 1428 meets the requirements of the following standards of safety for electrical equipment for measurement, control, and laboratory use:

- IEC 61010-1, EN 61010-1
- UL 61010-1
- CAN/CSA C22.2 No. 61010-1



**Note** For UL and other safety certifications, refer to the product label, or visit [ni.com/certification](http://ni.com/certification), search by model number or product line, and click the appropriate link in the Certification column.

## Electromagnetic Compatibility

Emissions .....	EN 55011 Class A at 10 m FCC Part 15A above 1 GHz
Immunity .....	EN 61326:1997 + A2:2001, Table 1
EMC/EMI .....	CE, C-Tick, and FCC Part 15 (Class A) Compliant



**Note** For EMC compliance, operate this device with shielded cabling.

## CE Compliance

The IMAQ PCI-1424 device meets the essential requirements of applicable European Directives, as amended for CE marking, as follows:

Low-Voltage Directive (safety).....	73/23/EEC
Electromagnetic Compatibility Directive (EMC) .....	89/336/EEC



**Note** Refer to the Declaration of Conformity (DoC) for this product for any additional regulatory compliance information. To obtain the DoC for this product, visit [ni.com/certification](http://ni.com/certification), search by model number or product line, and click the appropriate link in the Certification column.

---

# Technical Support and Professional Services

Visit the following sections of the National Instruments Web site at [ni.com](http://ni.com) for technical support and professional services:

- **Support**—Online technical support resources at [ni.com/support](http://ni.com/support) include the following:
  - **Self-Help Resources**—For answers and solutions, visit the award-winning National Instruments Web site for software drivers and updates, a searchable KnowledgeBase, product manuals, step-by-step troubleshooting wizards, thousands of example programs, tutorials, application notes, instrument drivers, and so on.
  - **Free Technical Support**—All registered users receive free Basic Service, which includes access to hundreds of Application Engineers worldwide in the NI Developer Exchange at [ni.com/exchange](http://ni.com/exchange). National Instruments Application Engineers make sure every question receives an answer.

For information about other technical support options in your area, go to [ni.com/services](http://ni.com/services) or contact your local branch at [ni.com/contact](http://ni.com/contact).

- **Training and Certification**—Visit [ni.com/training](http://ni.com/training) for self-paced training, eLearning virtual classrooms, interactive CDs, and Certification program information. You also can register for instructor-led, hands-on courses at locations around the world.
- **System Integration**—If you have time constraints, limited in-house technical resources, or other project challenges, National Instruments Alliance Partner members can help. To learn more, call your local NI office or visit [ni.com/alliance](http://ni.com/alliance).
- **Declaration of Conformity (DoC)**—A DoC is our claim of compliance with the Council of the European Communities using the manufacturer's declaration of conformity. This system affords the user protection for electronic compatibility (EMC) and product safety. You can obtain the DoC for your product by visiting [ni.com/certification](http://ni.com/certification).

- **Calibration Certificate**—If your product supports calibration, you can obtain the calibration certificate for your product at [ni.com/calibration](http://ni.com/calibration).

If you searched [ni.com](http://ni.com) and could not find the answers you need, contact your local office or NI corporate headquarters. Phone numbers for our worldwide offices are listed at the front of this manual. You also can visit the Worldwide Offices section of [ni.com/niglobal](http://ni.com/niglobal) to access the branch office Web sites, which provide up-to-date contact information, support phone numbers, email addresses, and current events.

# Glossary

---

## A

acquisition window	The image size specific to a video standard or camera resolution.
active line region	The region of lines actively being stored. Defined by a line start (relative to the vertical synchronization signal) and a line count.
active pixel region	The region of pixels actively being stored. Defined by a pixel start (relative to the horizontal synchronization signal) and a pixel count.
address	Value that identifies a specific location (or series of locations) in memory.
API	Application programming interface.
area	A rectangular portion of an acquisition window or frame that is controlled and defined by software.
ASIC	Application-Specific Integrated Circuit. A proprietary semiconductor component designed and manufactured to perform a set of specific functions for specific customer needs.

## B

buffer	Temporary storage for acquired data.
bus	A group of conductors that interconnect individual circuitry in a computer, such as the PCI bus; typically the expansion vehicle to which I/O or other devices are connected.

## D

DAQ	Data acquisition. (1) Collecting and measuring electrical signals from sensors, transducers, and test probes or fixtures and inputting them to a computer for processing. (2) Collecting and measuring the same kinds of electrical signals with A/D or DIO devices plugged into a computer, and possibly generating control signals with D/A and/or DIO devices in the same computer.
-----	--

**DMA** Direct memory access. A method by which data can be transferred to and from computer memory from and to a device or memory on the bus while the processor does something else; DMA is the fastest method of transferring data to/from computer memory.

**driver** Software that controls a specific hardware device, such as an image acquisition device.

## **E**

**external trigger** A voltage pulse from an external source that triggers an event such as A/D conversion.

## **F**

**field** For an interlaced video signal, a field is half the number of horizontal lines needed to represent a frame of video. The first field of a frame contains all the odd-numbered lines, the second field contains all of the even-numbered lines.

**FIFO** First-in first-out memory buffer. The first data stored is the first data sent to the acceptor; FIFOs are used on IMAQ devices to temporarily store incoming data until that data can be retrieved.

**frame** A complete image. In interlaced formats, a frame is composed of two fields.

## **G**

**gamma** The nonlinear change in the difference between the video signal's brightness level and the voltage level needed to produce that brightness.

## **I**

**interlaced** A video frame composed of two interleaved fields. The number of lines in a field are half the number of lines in an interlaced frame.

**L**

**LUT** Look-up table. Table containing values used to transform the gray-level values of an image. For each gray-level value in the image, the corresponding new value is obtained from the look-up table.

**M**

memory buffer *See* [buffer](#).

**N**

**NI-IMAQ** Driver software for National Instruments IMAQ hardware.

**NVRAM** Nonvolatile RAM. RAM that is not erased when a device loses power or is turned off.

**P**

**PCI** Peripheral Component Interconnect. A high-performance expansion bus architecture originally developed by Intel to replace ISA and EISA. PCI offers a theoretical maximum *transfer rate* of 133 Mbytes/s.

pixel Picture element. The smallest division that makes up the video scan line; for display on a computer monitor, a pixel's optimum dimension is square (aspect ratio of 1:1, or the width equal to the height).

pixel clock Divides the incoming horizontal video line into pixels.

**R**

real time A property of an event or system in which data is processed as it is acquired instead of being accumulated and processed at a later time.

ribbon cable A flat cable in which the conductors are side by side.

**ROI** Region of interest. An area of the image from a window displaying the image.

## S

scatter-gather DMA	A type of DMA that allows the DMA controller to reconfigure on-the-fly.
SDRAM	Synchronous dynamic RAM.
SO-DIMM	Small outline dual inline memory module.

## T

tap	A stream of pixels from a camera. Some cameras send multiple streams, or taps, of data over a cable simultaneously to increase transfer rate.
transfer rate	The rate, measured in bytes/s, at which data is moved from source to destination after software initialization and set up operations. The maximum rate at which the hardware can operate.
trigger	Any event that causes or starts some form of data capture.
trigger control and mapping circuitry	Circuitry that routes, monitors, and drives external and RTSI bus trigger lines. You can configure each of these lines to start or stop acquisition on a rising or falling edge.
TTL	Transistor-transistor logic.

## V

VI	Virtual Instrument. (1) A combination of hardware and/or software elements, typically used with a PC, that has the functionality of a classic stand-alone instrument. (2) A LabVIEW software module (VI), which consists of a front panel user interface and a block diagram program.
----	---

# Index

---

## A

- acquisition and region-of-interest (ROI) circuitry, 3-4
- acquisition start conditions, 3-4
- acquisition window control
  - active pixel region (acquisition window), 3-5
  - interlaced video, 3-5
  - region of interest, 3-5
- application software, Vision Development Module, 1-3

## B

- block diagram of IMAQ PCI-1424, 3-2

## C

- calibration certificate (NI resources), B-2
- clock signals, Pixel Clock $\pm$  signal (table), 4-3
- clocks, specifications, A-2
- Control<3..0> $\pm$  signal (table), 4-3
- conventions used in the manual, *v*
- CTS signal (table), 4-3

## D

- data formatter, multiple-tap, 3-3
- Data<31..0> $\pm$  signal (table), 4-3
- DCD signal (table), 4-3
- Declaration of Conformity (NI resources), B-1
- delayed acquisition start conditions, 3-5
- diagnostic tools (NI resources), B-1
- DMA controllers, 3-4
- documentation
  - conventions used in the manual, *v*
  - NI resources, B-1

- drivers (NI resources), B-1
- DSR signal (table), 4-3
- DTR signal (table), 4-3

## E

- Enable<D..A> $\pm$  signal (table), 4-3
- environment specifications, A-3
- equipment, optional, 2-2
- examples (NI resources), B-1
- external connection specifications, A-1
- External Trigger<3..0> $\pm$  signal (table), 4-3

## F

- frame/field selection, 3-5

## G

- GND signal (table), 4-3

## H

- hardware overview
  - acquisition and ROI, 3-4
  - acquisition window control, 3-5
  - block diagram, 3-2
  - board configuration NVRAM, 3-4
  - high-speed timing, 3-4
  - LUTs, 3-2
  - multiple-tap data formatter, 3-3
  - RS-232 serial interface, 3-3
  - scatter-gather DMA controllers, 3-4
  - SDRAM, 3-3
  - start conditions, 3-4
  - trigger control and mapping circuitry, 3-3
- help, technical support, B-1
- high-speed timing circuitry, 3-4

## I

- I/O connector
  - overview, 4-1
  - pin assignments (figure), 4-2
  - signal description (table), 4-3
- IMAQ PCI-1424
  - block diagram, 3-2
  - devices, safety information, 2-3
  - optional equipment, 2-2
  - overview and features, 1-1
  - requirements for getting started, 2-1
- installation
  - procedure, 2-5
  - unpacking the PCI-1424, 2-2
- instrument drivers (NI resources), B-1
- integration with DAQ and motion control, 1-4
- interlaced video, 3-5

## K

- KnowledgeBase, B-1

## L

- LabVIEW, Vision Builder AI, 1-3
- LUTs (lookup tables), 3-2

## M

- mapping circuitry, 3-3
- memory
  - board configuration NVRAM, 3-4
  - SDRAM, 3-3
- motion control, integrating with, 1-4
- multiple-tap data formatter, 3-3

## N

- National Instruments support and services, B-1

- NI-IMAQ driver software, 1-2
- NVRAM, 3-4

## O

- optional equipment, 2-2

## P

- PCI interface specifications, A-3
- PCI-1424 devices
  - software programming choices, 1-2
  - National Instruments IMAQ Vision, 1-3
  - NI-IMAQ driver software, 1-2
  - unpacking, 2-2
- physical specifications, A-3
- Pixel Clock± signal (table), 4-3
- power requirements, A-3
- programming examples (NI resources), B-1

## R

- RAM
  - board configuration NVRAM, 3-4
  - SDRAM, 3-3
- region of interest, in acquisition window control, 3-5
- region-of-interest (ROI) circuitry, 3-4
- requirements for getting started, 2-1
- RI signal (table), 4-3
- RS-232 serial interface, 3-3
- RTS signal (table), 4-3

## S

- safety
  - information, 2-3
  - specifications, A-4
- scatter-gather DMA controllers, 3-4
- SDRAM, 3-3

- serial interface (RS-232), 3-3
- signal connections
  - I/O connector
    - overview, 4-1
    - pin assignments (figure), 4-2
    - signal description (table), 4-3
- SIN signal (table), 4-3
- software
  - NI resources, B-1
  - programming choices
    - National Instruments IMAQ Vision, 1-3
    - NI-IMAQ driver software, 1-2
    - Vision Development Module, 1-3
- software-controlled start conditions, 3-4
- SOUT signal (table), 4-3
- specifications
  - clocks, A-2
  - environment, A-3
  - external connections, A-1
  - PCI interface, A-3

- physical, A-3
- power requirements, A-3
- safety, A-4
- start conditions
  - delayed acquisition, 3-5
  - frame/field selection, 3-5
  - software control, 3-4
  - trigger control, 3-4
- support, technical, B-1

## T

- technical support, B-1
- training and certification (NI resources), B-1
- trigger control and mapping circuitry, 3-3
- trigger controlled start conditions, 3-4
- troubleshooting (NI resources), B-1

## W

- Web resources, B-1