

Getting Started with the NI PCIe-1427

The NI PCIe-1427 (NI 1427) is a highly flexible PCI Express (PCIe) image acquisition device. The NI 1427 supports Base configuration Camera Link-compatible cameras. This document describes how to install and configure the necessary hardware and software components to begin using the NI 1427.

Installing the NI 1427

The following sections list the necessary and optional items for acquiring images with the NI 1427, important safety information, and instructions for unpacking, installing, and configuring the NI 1427.

What You Need to Get Started

You need the following items to set up and use the NI 1427:

- NI 1427 image acquisition device
- Computer running Windows 2000/XP with at least one available PCIe slot
- Base configuration Camera Link-compatible camera
- MDR 26-pin Camera Link cable
- NI Vision Acquisition Software 8.2.1 or later, which includes the NI-IMAQ driver software
- Optional software for developing your application:
 - NI Vision Development Module
 - NI Vision Builder for Automated Inspection
 - LabVIEW
 - LabWindows™/CVI™
 - Microsoft Visual Basic

Optional Equipment

National Instruments offers a variety of products for use with the NI 1427, including the following:

- NI Camera Link I/O Extension Board for additional triggering, timing, and I/O (part number 779352-01)
- 15-pin cable assembly kits for connecting the NI 1427 to general purpose digital I/O (part number 190912-04)
- Other National Instruments Vision, Data Acquisition (DAQ), or Motion Control devices
- RTSI bus cables for connecting the NI 1427 to other Vision, DAQ, or Motion Control devices (part number 776249-0x, where x is either 2, 3, 4, or 5 depending on the number of devices you want to connect)

Refer to the National Instruments catalog, visit ni.com, or call the National Instruments office nearest you for more specific information about these products.

Related Documentation

The following documents contain additional information that you may find helpful:

- *NI PCIe-1427 User Manual*—Contains important safety information; a hardware overview; specifications; and information about unpacking, installing, and configuring the NI 1427.
- *NI Vision Acquisition Software Release Notes*—Outlines new functionality, system requirements, installation procedures, and descriptions of the documentation included with the NI-IMAQ driver software.
- *NI Vision Hardware Help*—Contains fundamental programming concepts for NI-IMAQ driver software and terminology for using NI image acquisition devices.
- *Measurement & Automation Explorer Help for NI-IMAQ*—Describes how to configure NI-IMAQ driver software, NI image acquisition devices, and cameras using Measurement & Automation Explorer (MAX).
- *NI-IMAQ VI Reference Help*—Contains reference information about the LabVIEW palettes and VIs for NI-IMAQ driver software.
- *NI-IMAQ Function Reference Help*—Contains reference information about the LabWindows/CVI functions for NI-IMAQ driver software.

Safety Information



Caution The following paragraphs contain important safety information you *must* follow when installing and operating the device.

Do *not* operate the device in a manner not specified in the documentation. Misuse of the device may result in a hazard and may compromise the safety protection built into the device. If the device is damaged, turn it off and do *not* use it until service-trained personnel can check its safety. If necessary, return the device to National Instruments for repair.

Keep away from live circuits. Do *not* remove equipment covers or shields unless you are trained to do so. If signal wires are connected to the device, hazardous voltages can exist even when the equipment is turned off. To avoid a shock hazard, do *not* perform procedures involving cover or shield removal unless you are qualified to do so. Disconnect all field power prior to removing covers or shields.

If the device is rated for use with hazardous voltages ($>30 V_{\text{rms}}$, $42.4 V_{\text{pk}}$, or $60 V_{\text{dc}}$), it may require a safety earth-ground connection wire. Refer to the device specifications for maximum voltage ratings.

Because of the danger of introducing additional hazards, do *not* install unauthorized parts or modify the device. Use the device only with the chassis, modules, accessories, and cables specified in the installation instructions. All covers and filler panels *must* be installed while operating the device.

Do *not* operate the device in an explosive atmosphere or where flammable gases or fumes may be present. Operate the device only at or below the pollution degree stated in the specifications. Pollution consists of any foreign matter—solid, liquid, or gas—that may reduce dielectric strength or surface resistivity. The following is a description of pollution degrees.

- Pollution Degree 1—No pollution or only dry, nonconductive pollution occurs. The pollution has no effect.
- Pollution Degree 2—Normally only nonconductive pollution occurs. Occasionally, nonconductive pollution becomes conductive because of condensation.
- Pollution Degree 3—Conductive pollution or dry, nonconductive pollution occurs. Nonconductive pollution becomes conductive because of condensation.

Clean the device and accessories by brushing off light dust with a soft, nonmetallic brush. Remove other contaminants with a stiff, nonmetallic brush. The unit *must* be completely dry and free from contaminants before returning it to service.

You *must* insulate signal connections for the maximum voltage for which the device is rated. Do *not* exceed the maximum ratings for the device. Remove power from signal lines before connection to or disconnection from the device.



Caution National Instruments measurement products may be classified as either Measurement Category I or II. Operate products at or below the Measurement Category level specified in the hardware specifications.

Measurement Category¹: Measurement circuits are subjected to working voltages² and transient stresses (overvoltage) from the circuit to which they are connected during measurement or test. Measurement Category establishes standardized impulse withstand voltage levels that commonly occur in electrical distribution systems. The following is a description of Measurement (Installation³) Categories:

- Measurement Category I is for measurements performed on circuits *not* directly connected to the electrical distribution system referred to as MAINS⁴ voltage. This category is for measurements of voltages from specially protected secondary circuits. Such voltage measurements include signal levels, special equipment, limited-energy parts of equipment, circuits powered by regulated low-voltage sources, and electronics.
- Measurement Category II is for measurements performed on circuits directly connected to the electrical distribution system. This category refers to local-level electrical distribution, such as that provided by a standard wall outlet (e.g., 115 V for U.S. or 230 V for Europe). Examples of Measurement Category II are measurements performed on household appliances, portable tools, and similar products.
- Measurement Category III is for measurements performed in the building installation at the distribution level. This category refers to measurements on hard-wired equipment such as equipment in fixed installations, distribution boards, and circuit breakers. Other examples are wiring, including cables, bus-bars, junction boxes, switches, socket-outlets in the fixed installation, and stationary motors with permanent connections to fixed installations.

¹ Measurement Categories as defined in electrical safety standard IEC 61010-1.

² Working voltage is the highest rms value of an AC or DC voltage that can occur across any particular insulation.

³ Measurement Category is also referred to as Installation Category.

⁴ MAINS is defined as the (hazardous live) electrical supply system to which equipment is designed to be connected for the purpose of powering the equipment. Suitably rated measuring circuits may be connected to the MAINS for measuring purposes.

Unpacking

The NI 1427 ships in an antistatic package to prevent electrostatic discharge from damaging device components. To avoid such damage in handling your device, take the following precautions:

- Ground yourself via a grounding strap or by holding a grounded object, such as the computer chassis.
- Touch the antistatic package to a metal part of the computer chassis before removing the device from the package.



Caution *Never* touch the exposed pins of connectors.

Remove the device from the package and inspect it for loose components or any other signs of damage. Notify National Instruments if the device appears damaged in any way. Do *not* install a damaged device in the computer.

Store the NI 1427 in the antistatic package when not in use.

Installation

The following instructions are for general installation. Refer to the documentation provided by your computer manufacturer for specific instructions and warnings. Refer to the [Specifications](#) section for typical power requirements for the NI 1427.

1. Install the NI Vision Acquisition Software before installing the NI 1427. Refer to the *NI Vision Acquisition Software Release Notes* for specific installation instructions.
2. Power off and unplug the computer.



Caution To protect yourself and the computer from electrical hazards, the computer *must* remain unplugged until the installation is complete.

3. Remove the computer cover to expose the expansion slots.



Caution Installing a PCIe device into a PCI, PCI-X, AGP, or any non-PCIe slot can damage both the computer motherboard and the device. If you are unsure of the difference between connector types, do not install the device. Refer to the documentation provided by your computer manufacturer to determine the correct slot in which to install the NI 1427.

4. Choose an unused x1 or larger PCIe slot, and remove the corresponding expansion slot cover on the back panel of the computer. Figure 1 shows the different types of expansion slots available on most computers.



Note The NI 1427 is intended for a x1 PCIe slot. The NI 1427 will fit into, and can be used in, a x4, x8, or x16 PCIe slot.

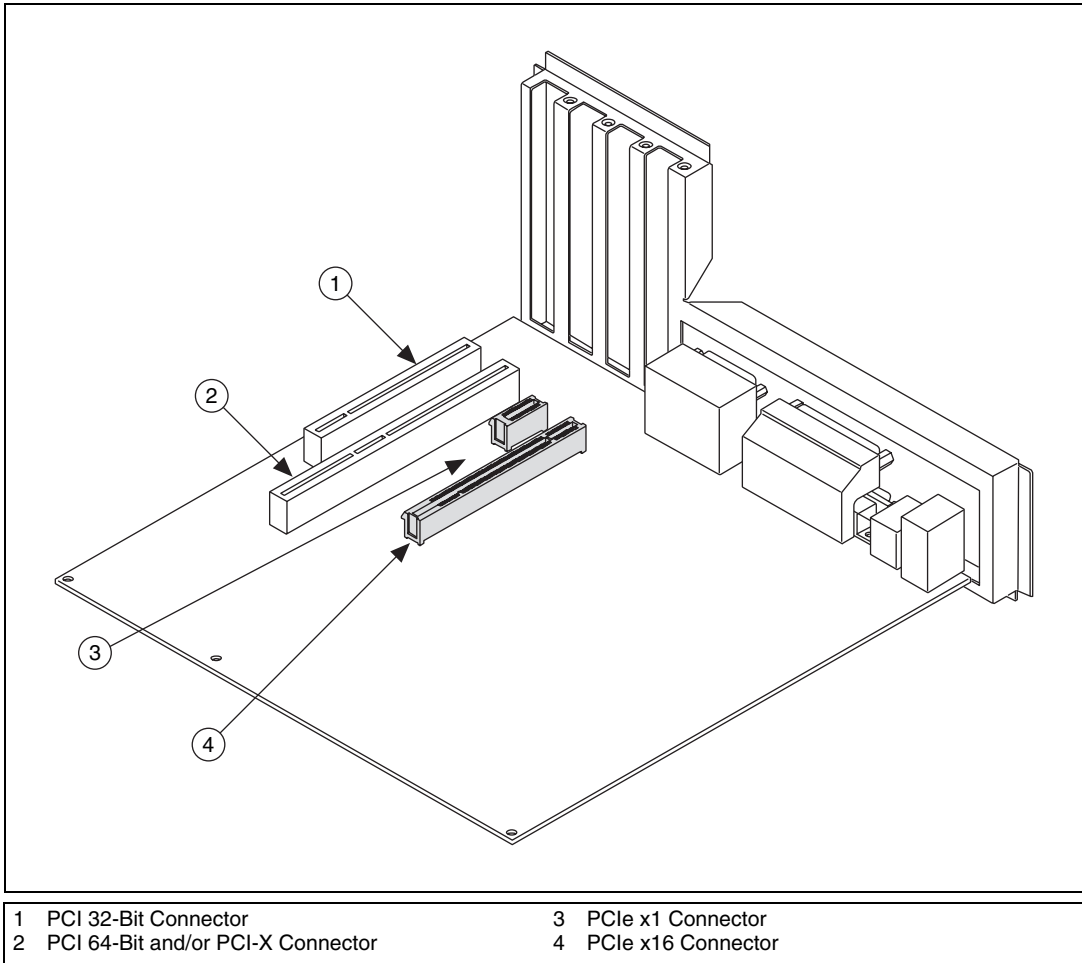

Figure 1. PC Expansion Slots

5. Touch a metal part on the computer case to discharge any static electricity that might be on your clothes or body before handling the NI 1427. Static electricity can damage the device.

6. Remove your device from the antistatic package and gently rock the device into the slot. The connection may be tight, but do *not* force the device into place.



Note Check that the bracket of your device aligns up with the hole in the back panel rail of the computer chassis.

7. Unless your computer secures expansion devices in a different manner, screw the mounting bracket of the device to the back panel rail of the computer.



Note If you will be using the NI Camera Link I/O Extension Board with the NI 1427, refer to the *NI Camera Link I/O Extension Board User Guide* for installation instructions.

8. Replace the computer cover.
9. Plug in and power on the computer.

The NI 1427 is now installed.

Configuring the NI 1427

After you have installed the NI 1427 and powered on the computer, the computer will recognize the device and assign resources to it. Use Measurement & Automation Explorer (MAX), the National Instruments configuration utility, to configure the NI 1427 for acquisition. Refer to the *Measurement & Automation Explorer Help for NI-IMAQ* for additional information about configuring the NI 1427.



Note Before configuring the device in MAX, ensure that you installed the NI-IMAQ driver software.

Interfacing with the NI 1427

The Camera Link standard defines physical connections between image acquisition devices and Camera Link cameras, and it allows for flexibility of image format and data transfer protocols. The camera manufacturer defines image parameters, such as image resolution and the number of bits per pixel, and camera control parameters, such as frame-on-demand and exposure control signals.

These variable parameters are defined on a per-camera basis in a camera file (<camera_model>.icd) supplied by National Instruments. NI-IMAQ uses the information in this camera file to program the NI 1427 to acquire images from a specific camera. Without this camera file, the driver does not have the information necessary to configure the NI 1427 to recognize the image format of the particular camera you are using. Refer to MAX for information about valid camera attributes for your camera and image acquisition device.

Many camera files are installed when you install NI-IMAQ, and many more are available for download from the National Instruments Industrial Camera Advisor at ni.com/camera. You can also create your own camera files using the NI Camera File Generator. This utility can be downloaded from ni.com/vision. When installing new camera files, save them to the <NI-IMAQ>\Data directory.

Contact National Instruments technical support to request camera files not available in the Camera Advisor. Refer to the [Where to Go for Support](#) section for information about National Instruments technical support.

MAX provides a simple interface for associating a camera file with the NI 1427. Use the following guidelines to access the camera file in MAX:

1. Launch MAX.
2. Expand the Devices and Interfaces branch of the configuration tree.
3. Expand the NI-IMAQ Devices branch.
4. Expand the NI PCIe-1427 branch.
5. Right-click Channel 0 and select **Camera**.
6. Select your camera from the menu. If your camera is not in the menu, verify that the appropriate camera file is installed in the <NI-IMAQ>\Data directory.



Note If you lose communication with the camera during an acquisition for any reason, such as unplugging a cable or powering off your camera, you must restart the acquisition to allow the device to relock the incoming timing signals.



Note The NI 1427 is equipped with a temperature monitor. The device will stop acquiring images if it reaches its maximum allowable temperature. An error will occur, reporting that the maximum temperature has been reached.

Specifications

The following specifications apply to the NI PCIe-1427 image acquisition device. These specifications are typical for the temperature range 0 °C to 55 °C, unless otherwise stated.

Trigger Characteristics

Number of external trigger I/O lines..... 4



Note External TTL lines on the 15-pin D-SUB connector become unavailable when the trigger source is set as an optically isolated input or an RS-422 input in the National Instruments Measurement & Automation Explorer (MAX) configuration software.

Trigger input

Voltage range 0 to 5 V (TTL)
Input high voltage 2.0 V
Input low voltage 0.8 V
Polarity Programmable, active-high or active-low

Trigger output

Voltage range 0 to 5 V (TTL)
Output high voltage 2.4 V at 13 mA source
Output low voltage 0.55 V at 10 mA sink
Polarity Programmable, active-high or active-low

Power-on state..... Input (high-impedance)
10 k Ω pull-up to 5 V

Maximum pulse rate..... 2 MHz

Input Characteristics

Optically Isolated Inputs

Number of channels 2

Type Current sinking or sourcing

Input voltage range..... 0 to 30 V

Input ON voltage 3.5 to 30 V

Input OFF voltage 0 to 2 V

Turn-on current.....	7.1 mA (typical) 14 mA (maximum)
Maximum pulse rate	100 kHz
Minimum pulse detected	10 μ s
Reverse polarity protection.....	Yes, -30 V

Quadrature Encoder/RS-422 Inputs

Number of channels.....	2
Input type.....	Differential or single-ended
Voltage range.....	0 to 5.5 VDC
Logic levels	
Differential input threshold	\pm 0.2 V (maximum), RS-422 compatible
Single-ended input threshold.....	TTL compatible
Input high voltage.....	2.0 V
Input low voltage.....	0.8 V
Maximum quadrature count rate.....	5 MHz

Clocks

Pixel clock frequency range.....	20 MHz to 85 MHz ¹
----------------------------------	-------------------------------



Note The Camera Link specification requires cameras to transmit at a minimum of 20 MHz.

PCI Express Interface

PCI Express compliance	Version 1.1
Native link width	x1
Up-plugging link width availability	x4, x8, x16

¹ This value corresponds to the serialized Camera Link cable transmission rate of 140 to 595 MHz.

Serial Interface

Baud rates supported 300, 600, 1200, 1800, 2000, 2400,
3600, 4800, 7200, or 9600 bps;
19.2, 38.4, 56, or 115.2 kbps

Power Requirements

Voltage +3.3 V (1.5 A)
+12 V (250 mA)

Physical Characteristics

Camera interface Camera Link 1.1
Dimensions 11.1 cm × 16.8 cm
(4.4 in. × 6.6 in.)
Weight 138 g (4.9 oz)

Environment

The NI 1427 is intended for indoor use only.

Operating temperature 0 °C to 55 °C

Storage temperature –20 °C to 70 °C

Relative humidity 5% to 90%, noncondensing

Pollution Degree 2

Approved at altitudes up to 2,000 m.

Safety

This product is designed to meet the requirements of the following standards of safety for electrical equipment for measurement, control, and laboratory use:

- IEC 61010-1, EN-61010-1
- UL 61010-1, CAN/CSA-C22.2 No. 61010-1



Note For UL and other safety certifications, refer to the product label or visit ni.com/certification, search by model number or product line, and click the appropriate link in the Certification column.

Electromagnetic Compatibility

This product is designed to meet the requirements of the following standards of EMC for electrical equipment for measurement, control, and laboratory use:

- EN 61326 EMC requirements; Minimum Immunity
- EN 55011 Emissions; Group 1, Class A
- CE, C-Tick, ICES, and FCC Part 15 Emissions; Class A



Note For EMC compliance, operate this device to product documentation.

CE Compliance

This product meets the essential requirements of applicable European Directives, as amended for CE marking, as follows:

- 73/23/EEC; Low-Voltage Directive (safety)
- 89/336/EEC; Electromagnetic Compatibility Directive (EMC)



Note Refer to the Declaration of Conformity (DoC) for this product for any additional regulatory compliance information. To obtain the DoC for this product, visit ni.com/certification, search by model number or product line, and click the appropriate link in the Certification column.

Waste Electrical and Electronic Equipment (WEEE)



EU Customers At the end of their life cycle, all products *must* be sent to a WEEE recycling center. For more information about WEEE recycling centers and National Instruments WEEE initiatives, visit ni.com/environment/weee.htm.

Where to Go for Support

The National Instruments Web site is your complete resource for technical support. At ni.com/support you have access to everything from troubleshooting and application development self-help resources to email and phone assistance from NI Application Engineers.

A Declaration of Conformity (DoC) is our claim of compliance with the Council of the European Communities using the manufacturer's declaration of conformity. This system affords the user protection for electronic compatibility (EMC) and product safety. You can obtain the DoC for your product by visiting ni.com/certification. If your product supports calibration, you can obtain the calibration certificate for your product at ni.com/calibration.

National Instruments corporate headquarters is located at 11500 North Mopac Expressway, Austin, Texas, 78759-3504. National Instruments also has offices located around the world to help address your support needs. For telephone support in the United States, create your service request at ni.com/support and follow the calling instructions or dial 512 795 8248. For telephone support outside the United States, contact your local branch office:

Australia 1800 300 800, Austria 43 0 662 45 79 90 0,
Belgium 32 0 2 757 00 20, Brazil 55 11 3262 3599,
Canada 800 433 3488, China 86 21 6555 7838,
Czech Republic 420 224 235 774, Denmark 45 45 76 26 00,
Finland 385 0 9 725 725 11, France 33 0 1 48 14 24 24,
Germany 49 0 89 741 31 30, India 91 80 41190000,
Israel 972 0 3 6393737, Italy 39 02 413091, Japan 81 3 5472 2970,
Korea 82 02 3451 3400, Lebanon 961 0 1 33 28 28,
Malaysia 1800 887710, Mexico 01 800 010 0793,
Netherlands 31 0 348 433 466, New Zealand 0800 553 322,
Norway 47 0 66 90 76 60, Poland 48 22 3390150,
Portugal 351 210 311 210, Russia 7 095 783 68 51,
Singapore 1800 226 5886, Slovenia 386 3 425 4200,
South Africa 27 0 11 805 8197, Spain 34 91 640 0085,
Sweden 46 0 8 587 895 00, Switzerland 41 56 200 51 51,
Taiwan 886 02 2377 2222, Thailand 662 278 6777,
United Kingdom 44 0 1635 523545

National Instruments, NI, ni.com, and LabVIEW are trademarks of National Instruments Corporation. Refer to the *Terms of Use* section on ni.com/legal for more information about National Instruments trademarks. Other product and company names mentioned herein are trademarks or trade names of their respective companies. For patents covering National Instruments products, refer to the appropriate location: **Help»Patents** in your software, the `patents.txt` file on your CD, or ni.com/patents.