

CALIBRATION PROCEDURE

NI 5114

This document contains instructions for writing an external calibration procedure for National Instruments PXI/PCI-5114 digitizers. This calibration procedure is intended for metrology labs. For more information about calibration, visit ni.com/calibration.

Contents

Conventions	2
Software Requirements	3
Documentation Requirements	4
Password	4
Calibration Interval	5
External Calibration	5
Self-Calibration	5
Test Equipment	5
Test Conditions	6
Calibration Procedures	6
Initial Setup	7
Self-Calibration	7
MAX	7
Scope SFP	8
NI-SCOPE	8
Verification	9
Vertical Offset and Vertical Gain Accuracy	10
Programmable Vertical Offset Accuracy	21
Timing Accuracy	27
Bandwidth and Flatness	30
Trigger Sensitivity	36
Adjustment	41
Appendix A: Calibration Options	45
Complete Calibration	46
Optional Calibration	47
Appendix B: Calibration Utilities	49
MAX	49
NI-SCOPE	49
Where to Go for Support	50

Conventions

The following conventions are used in this manual:

» The » symbol leads you through nested menu items and dialog box options to a final action. The sequence **File»Page Setup»Options** directs you to pull down the **File** menu, select the **Page Setup** item, and select **Options** from the last dialog box.

◆ The ◆ symbol indicates that the following text applies only to a specific product, a specific operating system, or a specific software version.



This icon denotes a note, which alerts you to important information.



This icon denotes a caution, which advises you of precautions to take to avoid injury, data loss, or a system crash. When this symbol is marked on a product, refer to the *Read Me First: Safety and Radio-Frequency Interference* document for information about precautions to take.

bold Bold text denotes items that you must select or click in the software, such as menu items and dialog box options. Bold text also denotes parameter names.

italic Italic text denotes variables, emphasis, a cross-reference, or an introduction to a key concept. Italic text also denotes text that is a placeholder for a word or value that you must supply.

monospace Text in this font denotes text or characters that you should enter from the keyboard, sections of code, programming examples, and syntax examples. This font is also used for the proper names of disk drives, paths, directories, programs, subprograms, subroutines, device names, functions, operations, variables, filenames, and extensions.

monospace italic Italic text in this font denotes text that is a placeholder for a word or value that you must supply.

Software Requirements

Calibrating the NI 5114 requires installing the following versions of NI-SCOPE.

Table 1. Required Software for NI 5114 Calibration

Device	NI-SCOPE Version
NI PXI-5114	2.9 or later
NI PCI-5114	3.1 or later

You can download NI-SCOPE from the Instrument Driver Network at ni.com/idnet. NI-SCOPE supports programming the *Self-Calibration* and *Verification* sections in a number of programming languages. However, only LabVIEW and C are supported for the *Adjustment* section.

NI-SCOPE includes all the functions and attributes necessary for calibrating the NI 5114. LabVIEW support is installed in `niScopeCal.llb`, and all calibration functions appear in the function palette. For LabWindows™/CVI™, the NI-SCOPE function panel `niScopeCal.fp` provides further help on the functions available in CVI. Refer to Table 2 for installed file locations.

Calibration functions are LabVIEW VIs or C function calls in the NI-SCOPE driver. The C function calls are valid for any compiler capable of calling a 32-bit DLL. Many of the functions use constants defined in the `niScopeCal.h` file. To use these constants in C, you must include `niScopeCal.h` in your code when you write the calibration procedure.

For more information on the calibration VIs and functions, refer to the *NI-SCOPE Function Reference Help* or the *NI-SCOPE LabVIEW Reference Help*. These references can be found in the *NI High-Speed Digitizers Help*. Refer to the *NI-SCOPE Readme* for the installed locations of these documents.

Table 2. Calibration File Locations after Installing NI-SCOPE

File Name and Location	Description
<code>IVI\Bin\niscope_32.dll</code>	NI-SCOPE driver containing the entire NI-SCOPE API, including calibration functions.
<code>IVI\Lib\msc\niscope.lib</code>	NI-SCOPE library for Microsoft C containing the entire NI-SCOPE API, including calibration functions.

Table 2. Calibration File Locations after Installing NI-SCOPE (Continued)

File Name and Location	Description
LabVIEW (<i>version</i>)\examples\instr\niScope	Directory of LabVIEW NI-SCOPE example VIs, including self-calibration.
LabVIEW (<i>version</i>)\instr.lib\niScopeCalibrate\niScopeCal.llb	LabVIEW VI library containing VIs for calling the NI-SCOPE calibration API.
IVI\Drivers\niScope\niScopeCal.fp	CVI function panel file that includes external calibration function prototypes and help on using NI-SCOPE in the CVI environment.
IVI\Include\niScopeCal.h	Calibration header file, which you must include in any C program accessing calibration functions. This file automatically includes niScope.h, which defines the rest of the NI-SCOPE interface.
IVI\Drivers\niScope\Examples	Directory of NI-SCOPE examples for CVI, C, Visual C++, and Visual Basic.

Documentation Requirements

You may find the following documentation helpful as you write your calibration procedure:

- *NI High-Speed Digitizers Getting Started Guide*
- *NI High-Speed Digitizers Help*
- *NI 5114 Specifications*
- *NI-SCOPE LabVIEW Reference Help* or *NI-SCOPE Function Reference Help*

These documents are installed with NI-SCOPE. You can also download the latest versions from ni.com/manuals.

Password

A password is required to open an external calibration session. If the password has not been changed since manufacturing, the password is “NI”.

Calibration Interval

External Calibration

The measurement accuracy requirements of your application determine how often you should externally calibrate the NI 5114. NI recommends that you perform a complete external calibration at least once every two years. You can shorten this interval based on the accuracy demands of your application or the requirements of your processes. Refer to [Appendix A: Calibration Options](#) for more information.

Self-Calibration

Self-calibration can be performed as necessary to compensate for environmental changes.



Caution Although you can use self-calibration repeatedly, self-calibrating the NI 5114 more than a few times a day may cause excessive wear on the relays over time.

Test Equipment

Table 3 lists the equipment required for externally calibrating the NI 5114. If you do not have the recommended instruments, use these specifications to select a substitute calibration standard.

Table 3. Required Equipment Specifications for NI 5114 External Calibration

Required Equipment	Recommended Equipment	Parameter Measured	Specification
Signal Generator	Fluke 9500B Oscilloscope Calibrator or Wavetek 9500 (with high-stability reference option) Fluke 9510 Test Head	DC Accuracy	DC $\pm(0.025\% + 25 \mu\text{V})$ into 1 M Ω
		Bandwidth, Trigger Sensitivity	$\pm 2\%$ output amplitude flatness for leveled sine wave up to 125 MHz relative to 50 kHz into 50 Ω
		Timing	± 2 ppm frequency accuracy
BNC cable	—	—	50 Ω



Note The delay times indicated in this procedure apply specifically to the Fluke 9500B calibrator. If you use a different calibrator, you may need to adjust these delay times.

Test Conditions

Follow these guidelines to optimize the connections and the environment during calibration:

- Always connect the calibrator test head directly to the input BNC of the digitizer, or use a short 50 Ω BNC coaxial cable if necessary. Long cables and wires act as antennae, picking up extra noise that can affect measurements.
 - Keep relative humidity between 10 and 90% non-condensing, or consult the digitizer hardware documentation for the optimum relative humidity.
 - Maintain an ambient temperature of 23 ± 5 °C.
 - Allow a warm-up time of at least 15 minutes after the NI-SCOPE driver is loaded. Unless manually disabled, the NI-SCOPE driver automatically loads with the operating system and enables the device. The warm-up time ensures that the measurement circuitry of the NI 5114 is at a stable operating temperature.
- ◆ For PXI digitizers:
 - Ensure that the PXI chassis fan speed is set to HI, that the fan filters are clean, and that the empty slots contain filler panels.
 - Plug the PXI chassis and the calibrator into the same power strip to avoid ground loops.
 - ◆ For PCI digitizers:
 - Plug the PC and the calibrator into the same power strip to avoid ground loops.

Calibration Procedures

The calibration process includes the following steps:

1. *Initial Setup*—Install the device and configure it in Measurement & Automation Explorer (MAX).
2. *Self-Calibration*—Adjust the self-calibration constants of the device.
3. *Verification*—Verify the existing operation of the device. This step confirms whether the device is operating within its specified range prior to calibration.

4. *Adjustment*—Perform an external adjustment of the device that adjusts the calibration constants with respect to a known voltage source. The adjustment procedure automatically stores the calibration date on the EEPROM to allow traceability.
5. *Reverification*—Repeat the verification procedure to ensure that the device is operating within its specifications after adjustment.

These steps are described in more detail in the following sections.



Note In some cases, the complete calibration procedure may not be required. Refer to [Appendix A: Calibration Options](#) for more information.

Initial Setup

Refer to the *NI High-Speed Digitizers Getting Started Guide* for information about how to install the software and hardware, and how to configure the device in MAX.

Self-Calibration

The NI 5114 includes precise internal circuits and references used during self-calibration to adjust for time and temperature drift. The digitizer gain, offset, flatness, and trigger timing are all corrected in self-calibration. Measuring the accuracy of these internal calibration circuits with another instrument during external calibration provides traceability for the verification procedure. Absolute accuracy is ensured by compensating for any error measured in the internal references.



Note Self-calibrate the digitizer before you perform *Verification*. NI-SCOPE includes self-calibration example programs for LabVIEW, CVI, and Microsoft Visual C.

You can initiate self-calibration using the following methods:

- MAX
- Scope Soft Front Panel (SFP)
- NI-SCOPE

MAX

To initiate self-calibration from MAX, complete the following steps:

1. Disconnect or disable any AC inputs to the digitizer.
2. Launch MAX.
3. Select **My System»Devices and Interfaces»NI-DAQmx Devices**.
4. Select the device that you want to calibrate.

5. Initiate self-calibration using one of the following methods:
 - Click **Self-Calibrate** in the upper right corner of MAX.
 - Right-click the name of the device in the MAX configuration tree and select **Self-Calibrate** from the drop-down menu.

Scope SFP

To initiate self-calibration from the Scope SFP, complete the following steps:

1. Disconnect or disable any AC inputs to the digitizer.
2. Launch the Scope SFP, which is available at **Start»All Programs»National Instruments»NI-SCOPE»Scope Soft Front Panel**
3. Select the device you want to calibrate using the Device Configuration dialog box by selecting **Edit»Device Configuration**.
4. Launch the Calibration dialog box by selecting **Utility»Self Calibration**.
5. Click **OK** to begin self-calibration.

NI-SCOPE

To self-calibrate the NI 5114 programmatically using NI-SCOPE, complete the following steps:

1. Disconnect or disable any AC inputs to the digitizer.
2. Open a session and obtain a session handle using the niScope Initialize VI.



Note Throughout the procedure, refer to the C/C++ function call parameters for the LabVIEW input values.

LabVIEW VI	C/C++ Function Call
	<p>Call <code>niScope_init</code> with the following parameters:</p> <p>vi: The returned session handle that you use to identify the instrument in all subsequent NI-SCOPE driver function calls</p> <p>resourceName: The device name assigned by MAX</p> <p>idQuery: <code>VI_FALSE</code></p> <p>resetDevice: <code>VI_TRUE</code></p>

3. Self-calibrate the digitizer using niScope Cal Self Calibrate VI.

LabVIEW VI	C/C++ Function Call
	<p>Call <code>niScope_CalSelf Calibrate</code> with the following parameters:</p> <p>sessionHandle: The instrument handle from <code>niScope_init</code></p> <p>channelList: <code>VI_NULL</code></p> <p>option: <code>VI_NULL</code></p>



Note Because the session is a standard session rather than an external calibration session, the new calibration constants are immediately stored in the EEPROM. Therefore, you can include this procedure in any application that uses the digitizer.

4. End the session using the niScope Close VI.

LabVIEW VI	C/C++ Function Call
	<p>Call <code>niScope_close</code> with the following parameter:</p> <p>vi: The instrument handle from <code>niScope_init</code></p>

Verification



Note After the 15-minute warm-up time, always self-calibrate the NI 5114 before beginning a verification procedure.

This section describes the program you must write to verify either the calibration test limits or the published specifications for the NI 5114. Refer to [Appendix A: Calibration Options](#) to determine which limits to use in these procedures.



Note If any of these tests fail immediately after you perform an external adjustment, make sure that you have met the requirements listed in the [Test Equipment](#) and [Test Conditions](#) sections before you return the digitizer to National Instruments for repair.

Vertical Offset and Vertical Gain Accuracy

Table 5 contains the input parameters for verifying both vertical offset accuracy and vertical gain accuracy of the NI 5114.

To verify vertical offset accuracy, complete the procedures described in the *Vertical Offset Accuracy* section for each of the 20 iterations listed in Table 5 for channel 0, then repeat the procedures for channel 1. The *Calibration Test Limits* and *Published Specifications* for vertical offset accuracy are shown in Table 5.

To verify vertical gain accuracy, complete the procedures described in the *Vertical Gain Accuracy* section for each of the 20 iterations listed in Table 7 for channel 0, then repeat the procedures for channel 1. The *Calibration Test Limits* and *Published Specifications* for vertical gain accuracy are shown in Table 6.

Table 4. NI 5114 Input Parameters for Vertical Offset Accuracy and Vertical Gain Accuracy Verification

Iteration	Max Input Frequency (Hz)	Range
1	125,000,000	0.04
2	125,000,000	0.1
3	125,000,000	0.2
4	125,000,000	0.4
5	125,000,000	1
6	125,000,000	2
7	125,000,000	4
8	125,000,000	10
9	125,000,000	20
10	125,000,000	40
11	20,000,000	0.04
12	20,000,000	0.1
13	20,000,000	0.2
14	20,000,000	0.4
15	20,000,000	1

Table 4. NI 5114 Input Parameters for Vertical Offset Accuracy and Vertical Gain Accuracy Verification (Continued)

Iteration	Max Input Frequency (Hz)	Range
16	20,000,000	2
17	20,000,000	4
18	20,000,000	10
19	20,000,000	20
20	20,000,000	40

Vertical Offset Accuracy

Complete the following steps to verify vertical offset accuracy of the NI 5114. You must verify both channels with each iteration listed in Table 5.

1. Open a session and obtain a session handle using the niScope Initialize VI.



Note Throughout the procedure, refer to the C/C++ function call parameters for the LabVIEW input values.

LabVIEW VI	C/C++ Function Call
	<p>Call <code>niScope_init</code> with the following parameters:</p> <p>resourceName: The device name assigned by MAX</p> <p>idQuery: <code>VI_FALSE</code></p> <p>resetDevice: <code>VI_TRUE</code></p>

- Configure the input impedance and the maximum input frequency using the niScope Configure Chan Characteristics VI.

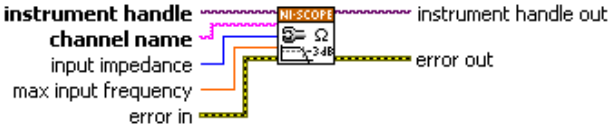
LabVIEW VI	C/C++ Function Call
 <p>The diagram shows a LabVIEW VI for configuring channel characteristics. It has five input terminals on the left: 'instrument handle' (blue), 'channel name' (orange), 'input impedance' (green), 'max input frequency' (red), and 'error in' (yellow). The 'error in' terminal is connected to a yellow dashed line. The VI is represented by a block with a 'NI-SCOPE' label and a resistor symbol. It has two output terminals on the right: 'instrument handle out' (blue) and 'error out' (yellow dashed line).</p>	<p>Call <code>niScope_ConfigureChanCharacteristics</code> with the following parameters:</p> <p>vi: The instrument handle from <code>niScope_init</code> channelList: "0" inputImpedance: <code>NISCOPE_VAL_1_MEG_OHM</code> maxInputFrequency: The <i>Maximum Input Frequency</i> value in Table 5 for the current iteration</p>

- Configure the common vertical properties using the niScope Configure Vertical VI.

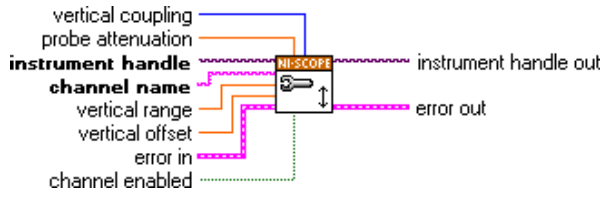
LabVIEW VI	C/C++ Function Call
 <p>The diagram shows a LabVIEW VI for configuring vertical properties. It has eight input terminals on the left: 'vertical coupling' (blue), 'probe attenuation' (orange), 'instrument handle' (blue), 'channel name' (orange), 'vertical range' (green), 'vertical offset' (red), 'error in' (yellow), and 'channel enabled' (dotted green). The 'error in' terminal is connected to a yellow dashed line. The VI is represented by a block with a 'NI-SCOPE' label and a vertical scale symbol. It has two output terminals on the right: 'instrument handle out' (blue) and 'error out' (yellow dashed line).</p>	<p>Call <code>niScope_ConfigureVertical</code> with the following parameters:</p> <p>coupling: <code>NISCOPE_VAL_DC</code> probeAttenuation: 1.0 vi: The instrument handle from <code>niScope_init</code> channelList: "0" range: The <i>Range</i> value in Table 4 for the current iteration offset: 0.0 enabled: <code>NISCOPE_VAL_TRUE</code></p>

- Configure the horizontal properties using the niScope Configure Horizontal Timing VI.

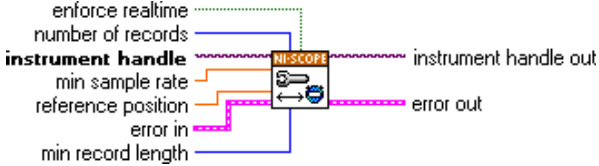
LabVIEW VI	C/C++ Function Call
	<p>Call <code>niScope_ConfigureHorizontalTiming</code> with the following parameters:</p> <p>enforceRealtime: <code>NISCOPE_VAL_TRUE</code></p> <p>numRecords: 1</p> <p>vi: The instrument handle from <code>niScope_init</code></p> <p>minSampleRate: 10,000,000</p> <p>refPosition: 50.0</p> <p>minNumPts: 100,000</p>

- Commit all the parameter settings to hardware using the niScope Commit VI.

LabVIEW VI	C/C++ Function Call
	<p>Call <code>niScope_Commit</code> with the following parameter:</p> <p>vi: The instrument handle from <code>niScope_init</code></p>

- Short-circuit the channel 0 input of the digitizer by connecting the calibrator test head directly to the digitizer and grounding the output of the calibrator.
- Wait 500 ms for the calibrator to ground its output.
- Initiate a waveform acquisition using the niScope Initiate Acquisition VI.

LabVIEW VI	C/C++ Function Call
	<p>Call <code>niScope_InitiateAcquisition</code> with the following parameter:</p> <p>vi: The instrument handle from <code>niScope_init</code></p>

9. Fetch a waveform from the digitizer and perform a voltage average measurement using the niScope Fetch Measurement (poly) VI. Select the Measurement Scalar DBL instance of the VI.

LabVIEW VI	C/C++ Function Call
	<p>Call <code>niScope_Fetch Measurement</code> with the following parameters:</p> <p>timeout: 1.0 vi: The instrument handle from <code>niScope_init</code> channelList: "0" scalarMeasFunction: <code>NISCOPE_VAL_VOLTAGE_AVERAGE</code></p>

Compare the resulting average voltage to the value listed in the *Calibration Test Limits* column or the *Published Specifications* column in Table 5 that corresponds to the settings used. If the result is within the selected test limit, the device has passed this portion of the verification.

10. Repeat steps 2 through 9 for each iteration in Table 4.
11. Move the calibrator test head to digitizer input channel 1 and repeat steps 2 through 10 for every configuration in Table 4, changing the value of the **channelList** parameter from "0" to "1".
12. End the session using the niScope Close VI.

LabVIEW VI	C/C++ Function Call
	<p>Call <code>niScope_close</code> with the following parameter:</p> <p>vi: The instrument handle from <code>niScope_init</code></p>

You have finished verifying the vertical offset accuracy of the NI 5114.

Table 5. NI 5114 Vertical Offset Limits

Range	Calibration Test Limits (V)		Published Specifications (V)	
	PXI	PCI	PXI	PCI
0.04	±0.00024	±0.00032	±0.00032	±0.0004
0.1	±0.0002	±0.00048	±0.0005	±0.00058
0.2	±0.0004	±0.00068	±0.0008	±0.00088
0.4	±0.0008	±0.0008	±0.0014	±0.00148
1	±0.002	±0.002	±0.0032	±0.00328
2	±0.004	±0.004	±0.0062	±0.00628
4	±0.008	±0.008	±0.0122	±0.01228
10	±0.02	±0.02	±0.0302	±0.03028
20	±0.04	±0.04	±0.0602	±0.06028
40	±0.08	±0.08	±0.1202	±0.12028

Vertical Gain Accuracy

Complete the following steps to verify the vertical gain accuracy of the NI 5114. You must verify both channels with each iteration listed in Table 4.

1. Open a session and obtain a session handle using the niScope Initialize VI.

LabVIEW VI	C/C++ Function Call
	<p>Call <code>niScope_init</code> with the following parameters:</p> <p>resourceName: The device name assigned by MAX idQuery: <code>VI_FALSE</code> resetDevice: <code>VI_TRUE</code></p>

- Configure the input impedance and the maximum input frequency using the niScope Configure Chan Characteristics VI.

LabVIEW VI	C/C++ Function Call
<p>instrument handle channel name input impedance max input frequency error in</p> <p>instrument handle out error out</p>	<p>Call <code>niScope_ConfigureChanCharacteristics</code> with the following parameters:</p> <p>channelList: "0" inputImpedance: <code>NISCOPE_VAL_1_MEG_OHM</code> maxInputFrequency: The <i>Maximum Input Frequency</i> value in Table 4 for the current iteration</p>

- Configure the common vertical properties using the niScope Configure Vertical VI.

LabVIEW VI	C/C++ Function Call
<p>vertical coupling probe attenuation instrument handle channel name vertical range vertical offset error in channel enabled</p> <p>instrument handle out error out</p>	<p>Call <code>niScope_ConfigureVertical</code> with the following parameters:</p> <p>coupling: <code>NISCOPE_VAL_DC</code> probeAttenuation: 1.0 vi: The instrument handle from <code>niScope_init</code> channelList: "0" range: The <i>Range</i> value in Table 4 for the current iteration offset: 0.0 enabled: <code>NISCOPE_VAL_TRUE</code></p>

- Configure the horizontal properties using the niScope Configure Horizontal Timing VI.

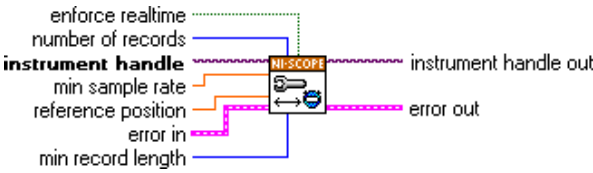
LabVIEW VI	C/C++ Function Call
	<p>Call <code>niScope_ConfigureHorizontalTiming</code> with the following parameters:</p> <p>enforceRealtime: <code>NISCOPE_VAL_TRUE</code></p> <p>numRecords: 1</p> <p>vi: The instrument handle from <code>niScope_init</code></p> <p>minSampleRate: 10,000,000</p> <p>refPosition: 50.0</p> <p>minNumPts: 100,000</p>

- Commit all the parameter settings to hardware using the niScope Commit VI.

LabVIEW VI	C/C++ Function Call
	<p>Call <code>niScope_Commit</code> with the following parameter:</p> <p>vi: The instrument handle from <code>niScope_init</code></p>

- Connect the calibrator test head directly to the channel 0 input of the digitizer and output the *Positive Input* voltage in Table 6 that corresponds to the vertical range used with a 1 MΩ load impedance.
- Wait 2,500 ms for the impedance matching and frequency of the calibrator to settle.
- Initiate a waveform acquisition using the niScope Initiate Acquisition VI.

LabVIEW VI	C/C++ Function Call
	<p>Call <code>niScope_InitiateAcquisition</code> with the following parameter:</p> <p>vi: The instrument handle from <code>niScope_init</code></p>

9. Fetch a waveform from the digitizer and perform a voltage average measurement using the niScope Fetch Measurement (poly) VI. Select the Measurement Scalar DBL instance of the VI. This value is the *Measured Positive Voltage* used in step 14.

LabVIEW VI	C/C++ Function Call
	<p>Call niScope_Fetch Measurement with the following parameters:</p> <p>timeout: 1.0</p> <p>vi: The instrument handle from niScope_init</p> <p>channelList: "0"</p> <p>scalarMeasFunction: NISCOPE_VAL_VOLTAGE_AVERAGE</p>

10. Using the calibrator, output the *Negative Input* voltage listed in Table 6 that corresponds to the vertical range used.
11. Wait 2,500 ms for the impedance matching and frequency of the calibrator to settle.
12. Initiate a waveform acquisition using the niScope Initiate Acquisition VI.

LabVIEW VI	C/C++ Function Call
	<p>Call niScope_Initiate Acquisition with the following parameter:</p> <p>vi: The instrument handle from niScope_init</p>

13. Fetch a waveform from the digitizer and perform a voltage average measurement using the niScope Fetch Measurement (poly) VI. Select the Measurement Scalar DBL instance of the VI. This value is the *Measured Negative Voltage* used in step 14.

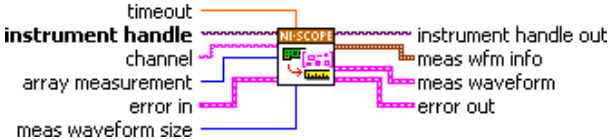
LabVIEW VI	C/C++ Function Call
	<p>Call niScope_Fetch Measurement with the following parameters:</p> <p>timeout: 1.0</p> <p>vi: The instrument handle from niScope_init</p> <p>channelList: "0"</p> <p>scalarMeasFunction: NISCOPE_VAL_VOLTAGE_AVERAGE</p>

14. Calculate the error in the vertical gain as a percentage of input using the following formula:

$$error = \left(\left(\frac{a-b}{c-d} \right) - 1 \right) \times 100$$

where

- a = the *Measured Positive Voltage*
- b = the *Measured Negative Voltage*
- c = the applied *Positive Voltage*
- d = the applied *Negative Voltage*

Compare the resulting percent error to the *Calibration Test Limits* column or the *Published Specifications* column listed in Table 6. If the result is within the selected test limit, the device has passed this portion of the verification.

15. Repeat steps 2 through 14 for each iteration in Table 5.
16. Move the calibrator test head to the digitizer input channel 1 and repeat steps 2 through 15 for every iteration in Table 6, changing the value of the **channelList** parameter from "0" to "1".

17. End the session using the niScope Close VI.

LabVIEW VI	C/C++ Function Call
	<p>Call <code>niScope_close</code> with the following parameter:</p> <p>vi: The instrument handle from <code>niScope_init</code></p>

You have finished verifying the vertical gain accuracy of the NI 5114.

Table 6. NI 5114 Vertical Gain Stimuli, Calibration Test Limits, and Published Specifications

Range (V)	Positive Input (V)	Negative Input (V)	Calibration Test Limits	Published Specifications
0.04	0.018	-0.018	±1.3975%	±1.5%
0.1	0.045	-0.045	±1.3975%	±1.5%
0.2	0.09	-0.09	±1.3975%	±1.5%
0.4	0.18	-0.18	±1.3975%	±1.5%
1	0.45	-0.45	±1.3975%	±1.5%
2	0.9	-0.9	±1.3975%	±1.5%
4	1.8	-1.8	±1.3975%	±1.5%
10	4.5	-4.5	±1.3975%	±1.5%
20	9	-9	±1.3975%	±1.5%
40	18	-18	±1.3975%	±1.5%

Programmable Vertical Offset Accuracy

Complete the following steps to verify the programmable vertical offset accuracy for each digitizer channel.

1. Open a session and obtain a session handle using the niScope Initialize VI.

LabVIEW VI	C/C++ Function Call
 <p>resource name id query reset device error in</p> <p>instrument handle error out</p>	<p>Call <code>niScope_init</code> with the following parameters:</p> <p>resourceName: The device name assigned by MAX idQuery: VI_FALSE resetDevice: VI_TRUE</p>

2. Configure the input impedance and the maximum input frequency using the niScope Configure Chan Characteristics VI.

LabVIEW VI	C/C++ Function Call
 <p>instrument handle channel name input impedance max input frequency error in</p> <p>instrument handle out error out</p>	<p>Call <code>niScope_ConfigureChanCharacteristics</code> with the following parameters:</p> <p>vi: The instrument handle from <code>niScope_init</code> channelList: "0" inputImpedance: NISCOPES_VAL_1_MEG_OHM maxInputFrequency: 20,000,000</p>

3. Configure the common vertical properties using the niScope Configure Vertical VI.

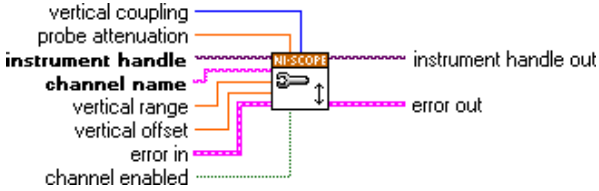
LabVIEW VI	C/C++ Function Call
	<p>Call <code>niScope_ConfigureVertical</code> with the following parameters:</p> <p>coupling: NISCOPE_VAL_DC probeAttenuation: 1.0 vi: The instrument handle from <code>niScope_init</code> channelList: "0" range: The <i>Range</i> value in Table 7 for the current iteration offset: The <i>Positive Offset</i> setting value in Table 7 for the current iteration enabled: NISCOPE_VAL_TRUE</p>

4. Configure the horizontal properties using the niScope Configure Horizontal Timing VI.

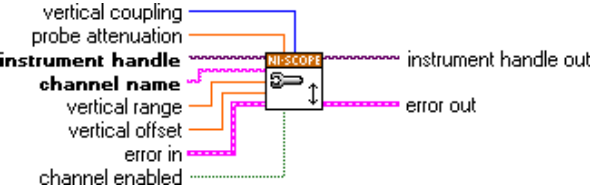
LabVIEW VI	C/C++ Function Call
	<p>Call <code>niScope_ConfigureHorizontalTiming</code> with the following parameters:</p> <p>enforceRealtime: NISCOPE_VAL_TRUE numRecords: 1 vi: The instrument handle from <code>niScope_init</code> minSampleRate: 10,000,000 refPosition: 50.0 minNumPts: 100,000</p>

- Commit all the parameter settings to hardware using the niScope Commit VI.

LabVIEW VI	C/C++ Function Call
	<p>Call <code>niScope_Commit</code> with the following parameter:</p> <p>vi: The instrument handle from <code>niScope_init</code></p>

- Connect the calibrator test head directly to the channel 0 input of the digitizer.
- Output the *Positive Output* voltage listed in Table 7 for the current iteration with a 1 MΩ load impedance.
- Wait 2,500 ms for the impedance matching and frequency of the calibrator to settle.
- Initiate a waveform acquisition using the niScope Initiate Acquisition VI.

LabVIEW VI	C/C++ Function Call
	<p>Call <code>niScope_InitiateAcquisition</code> with the following parameter:</p> <p>vi: The instrument handle from <code>niScope_init</code></p>

- Fetch a waveform from the digitizer and perform a voltage average measurement using the niScope Fetch Measurement (poly) VI. Select the Measurement Scalar DBL instance of the VI. This value is the *Measured Positive Voltage* used in step 17.

LabVIEW VI	C/C++ Function Call
	<p>Call <code>niScope_FetchMeasurement</code> with the following parameters:</p> <p>timeout: 1.0</p> <p>vi: The instrument handle from <code>niScope_init</code></p> <p>channelList: "0"</p> <p>scalarMeasFunction: <code>NISCOPE_VAL_VOLTAGE_AVERAGE</code></p>

11. Configure the common vertical properties using the niScope Configure Vertical VI.

LabVIEW VI	C/C++ Function Call
	<p>Call <code>niScope_ConfigureVertical</code> with the following parameters:</p> <p>coupling: <code>NISCOPE_VAL_DC</code> probeAttenuation: <code>1.0</code> vi: The instrument handle from <code>niScope_init</code> channelList: <code>"0"</code> range: The <i>Range</i> value in Table 7 for the current iteration offset: The <i>Negative Offset</i> setting in Table 7 for the current iteration enabled: <code>NISCOPE_VAL_TRUE</code></p>

12. Commit all the parameter settings to hardware using the niScope Commit VI.

LabVIEW VI	C/C++ Function Call
	<p>Call <code>niScope_Commit</code> with the following parameter:</p> <p>vi: The instrument handle from <code>niScope_init</code></p>

13. Connect the calibrator test head directly to the channel 0 input of the digitizer and output the *Negative Offset* voltage listed in Table 7 for the current iteration with a 1 M Ω load impedance.
14. Wait 2,500 ms for the impedance matching and frequency of the calibrator to settle.
15. Initiate a waveform acquisition using the niScope Initiate Acquisition VI.

LabVIEW VI	C/C++ Function Call
	<p>Call <code>niScope_InitiateAcquisition</code> with the following parameter:</p> <p>vi: The instrument handle from <code>niScope_init</code></p>

16. Fetch a waveform from the digitizer and perform a voltage average measurement using the niScope Fetch Measurement (poly) VI. Select the Measurement Scalar DBL instance of the VI. This value is the *Measured Negative Voltage* used in step 17.

LabVIEW VI	C/C++ Function Call
	<p>Call niScope_FetchMeasurement with the following parameters:</p> <p>timeout: 1.0 vi: The instrument handle from niScope_init channelList: "0" scalarMeasFunction: NISCOPE_VAL_VOLTAGE _AVERAGE</p>

17. Calculate the error in the programmable vertical offset as a percentage of input using the following formula:

$$error = \left(\left(\frac{a-b}{c-d} \right) - 1 \right) \times 100$$

where

a is the *Measured Positive Voltage*

b is the *Measured Negative Voltage*

c is the applied *Positive Voltage*

d is the applied *Negative Voltage*

Compare the resulting percent to the *Calibration Test Limits* column or the *Published Specifications* column listed in Table 7. If the result is within the selected test limit, the device has passed this portion of the verification.

18. Repeat steps 2 through 17 for each iteration in Table 7.
19. Move the calibrator test head to the digitizer input channel 1 and repeat steps 2 through 18, changing the value of the **channelList** parameter from "0" to "1".

20. End the session using the niScope Close VI.

LabVIEW VI	C/C++ Function Call
	<p>Call <code>niScope_close</code> with the following parameter:</p> <p>vi: The instrument handle from <code>niScope_init</code></p>

You have finished verifying the programmable vertical offset accuracy of the NI 5114.

Table 7. NI 5114 Programmable Vertical Offset Accuracy Stimuli, Calibration Test Limits, and Published Specifications

Iteration	Range (V)	Positive Offset (V)	Negative Offset (V)	Calibration Test Limits	Published Specifications
1	0.04	0.8	-0.8	±1.95%	±2%
2	0.1	0.8	-0.8	±1.95%	±2%
3	0.2	0.8	-0.8	±1.95%	±2%
4	0.4	0.8	-0.8	±1.95%	±2%
5	1	8	-8	±1.95%	±2%
6	2	8	-8	±1.95%	±2%
7	4	8	-8	±1.95%	±2%
8	10	30	-30	±1.95%	±2%
9	20	25	-25	±1.95%	±2%
10	40	15	-15	±1.95%	±2%

Timing Accuracy

Complete the following steps to verify the timing accuracy for the NI 5114.

1. Open a session and obtain a session handle using the niScope Initialize VI.

LabVIEW VI	C/C++ Function Call
 <p>resource name id query reset device error in</p> <p>instrument handle error out</p>	<p>Call <code>niScope_init</code> with the following parameters:</p> <p>resourceName: The device name assigned by MAX idQuery: <code>VI_FALSE</code> resetDevice: <code>VI_TRUE</code></p>

2. Configure the input impedance and the maximum input frequency using the niScope Configure Chan Characteristics VI.

LabVIEW VI	C/C++ Function Call
 <p>instrument handle channel name input impedance max input frequency error in</p> <p>instrument handle out error out</p>	<p>Call <code>niScope_ConfigureChanCharacteristics</code> with the following parameters:</p> <p>channelList: "0" inputImpedance: <code>NISCOPE_VAL_50_OHM</code> maxInputFrequency: 20,000,000</p>

3. Configure the common vertical properties using the niScope Configure Vertical VI.

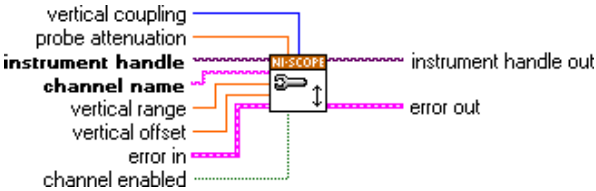
LabVIEW VI	C/C++ Function Call
 <p>vertical coupling probe attenuation instrument handle channel name vertical range vertical offset error in channel enabled</p> <p>instrument handle out error out</p>	<p>Call <code>niScope_ConfigureVertical</code> with the following parameters:</p> <p>coupling: <code>NISCOPE_VAL_DC</code> probeAttenuation: 1.0 vi: The instrument handle from <code>niScope_init</code> channelList: "0" range: 2.0 offset: 0.0 enabled: <code>NISCOPE_VAL_TRUE</code></p>

- Configure the horizontal properties using the niScope Configure Horizontal Timing VI.

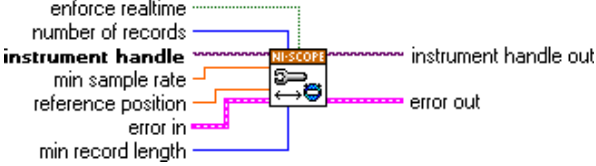
LabVIEW VI	C/C++ Function Call
	<p>Call <code>niScope_ConfigureHorizontalTiming</code> with the following parameters:</p> <p>enforceRealtime: <code>NISCOPE_VAL_TRUE</code></p> <p>numRecords: 1</p> <p>vi: The instrument handle from <code>niScope_init</code></p> <p>minSampleRate: 250,000,000</p> <p>refPosition: 50.0</p> <p>minNumPts: 2,500,000</p>

- Commit all the parameter settings to hardware using the niScope Commit VI.

LabVIEW VI	C/C++ Function Call
	<p>Call <code>niScope_Commit</code> with the following parameter:</p> <p>vi: The instrument handle from <code>niScope_init</code></p>

- Connect the scope calibrator test head directly to the channel 0 input of the digitizer. Configure the calibrator to output an exact 11 MHz sine wave with 1 V_{pk-pk} amplitude and 50 Ω load impedance.
- Wait 2,500 ms for the impedance matching and frequency of the calibrator to settle.
- Initiate a waveform acquisition using the niScope Initiate Acquisition VI.

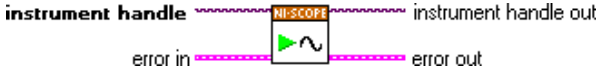
LabVIEW VI	C/C++ Function Call
	<p>Call <code>niScope_InitiateAcquisition</code> with the following parameter:</p> <p>vi: The instrument handle from <code>niScope_init</code></p>

9. Retrieve a waveform using the niScope Fetch (poly) VI. Select the WDT instance of the VI. Use the default value for the **timestamp Type** parameter.

LabVIEW VI	C/C++ Function Call
	<p>Call <code>niScope_Fetch</code> Measurement with the following parameters:</p> <p>timeout: 5.0 vi: The instrument handle from <code>niScope_init</code> channelList: "0" numSamples: -1</p>

10. Measure the exact frequency of the peak around 11 MHz using the Extract Single Tone Information VI with the following inputs.
 - **advanced search»approx freq.:** -1
 - **advanced search»search:** 5
 - **export signals:** 0 (none)

LabVIEW VI	C/C++ Function Call
	<p>Perform an FFT on the array of data from step 9.</p>

11. Calculate the error in timing as parts per million (ppm) using the following formula:

$$\text{error} = (a - 11,000,000) / 11$$

where *a* is the measured frequency.

Compare the result to the *Calibration Test Limits* column or the *Published Specifications* column listed in Table 8. If the result is within the selected test limit, the device has passed this portion of the verification.



Note The same time source is used for both channel 0 and channel 1, so you only need to verify the timing accuracy on one channel.

12. End the session using the niScope Close VI.

LabVIEW VI	C/C++ Function Call
	<p>Call <code>niScope_close</code> with the following parameter:</p> <p>vi: The instrument handle from <code>niScope_init</code></p>

You have finished verifying the timing accuracy of the NI 5114.

Table 8. NI 5114 Timing Accuracy Limits and Published Specifications

Calibration Test Limits	Published Specifications
±5.3 ppm	±25 ppm

Bandwidth and Flatness

Complete the following steps to verify the bandwidth and flatness of the NI 5114. You must verify both channels with each iteration listed in Table 9.

1. Open a session and obtain a session handle using the niScope Initialize VI.

LabVIEW VI	C/C++ Function Call
	<p>Call <code>niScope_init</code> with the following parameters:</p> <p>resourceName: The device name assigned by MAX idQuery: <code>VI_FALSE</code> resetDevice: <code>VI_TRUE</code></p>

- Configure the input impedance and the maximum input frequency using the niScope Configure Chan Characteristics VI.

LabVIEW VI	C/C++ Function Call
<p>instrument handle channel name input impedance max input frequency error in</p> <p>instrument handle out error out</p>	<p>Call <code>niScope_ConfigureChanCharacteristics</code> with the following parameters:</p> <p>vi: The instrument handle from <code>niScope_init</code> channelList: "0" inputImpedance: <code>NISCOPE_VAL_50_OHM</code> maxInputFrequency: The <i>Maximum Input Frequency</i> value in Table 9 for the current iteration</p>

- Configure the common vertical properties using the niScope Configure Vertical VI.

LabVIEW VI	C/C++ Function Call
<p>vertical coupling probe attenuation instrument handle channel name vertical range vertical offset error in channel enabled</p> <p>instrument handle out error out</p>	<p>Call <code>niScope_ConfigureVertical</code> with the following parameters:</p> <p>coupling: <code>NISCOPE_VAL_DC</code> probeAttenuation: 1.0 vi: The instrument handle from <code>niScope_init</code> channelList: "0" range: The <i>Range</i> value in Table 9 for the current iteration offset: 0.0 enabled: <code>NISCOPE_VAL_TRUE</code></p>

- Configure the horizontal properties using the niScope Configure Horizontal Timing VI.

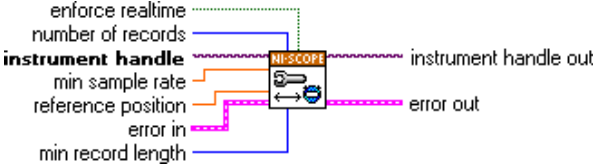
LabVIEW VI	C/C++ Function Call
	<p>Call <code>niScope_ConfigureHorizontalTiming</code> with the following parameters:</p> <p>enforceRealtime: <code>NISCOPE_VAL_TRUE</code></p> <p>numRecords: 1</p> <p>vi: The instrument handle from <code>niScope_init</code></p> <p>minSampleRate: 10,000,000</p> <p>refPosition: 50.0</p> <p>minNumPts: 30,000</p>

- Commit all the parameter settings to hardware using the niScope Commit VI.

LabVIEW VI	C/C++ Function Call
	<p>Call <code>niScope_Commit</code> with the following parameter:</p> <p>vi: The instrument handle from <code>niScope_init</code></p>

- Connect the calibrator test head directly to the channel 0 input of the digitizer. Configure the calibrator to output a 50 kHz sine wave with peak-to-peak voltage amplitude set to half the vertical range of the digitizer. Configure the load impedance of the calibrator to match the input impedance of the digitizer.
- Wait 2,500 ms for the impedance matching and frequency of the calibrator to settle.
- Initiate a waveform acquisition using the niScope Initiate Acquisition VI.

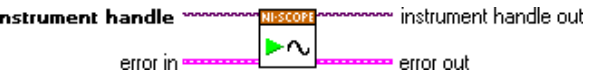
LabVIEW VI	C/C++ Function Call
	<p>Call <code>niScope_InitiateAcquisition</code> with the following parameter:</p> <p>vi: The instrument handle from <code>niScope_init</code></p>

9. Fetch a waveform from the digitizer and perform a voltage RMS measurement using the niScope Fetch (poly) Measurement VI. Select the Measurement Scalar DBL instance of the VI. This value is the *Measured RMS Voltage of 50 kHz Sine Wave* used in step 11. e.

LabVIEW VI	C/C++ Function Call
	<p>Call <code>niScope_Fetch Measurement</code> with the following parameters:</p> <p>timeout: 1.0 vi: The instrument handle from <code>niScope_init</code> channelList: "0" scalarMeasFunction: <code>NISCOPE_VAL_VOLTAGE_RMS</code></p>

10. Configure the horizontal properties using the niScope Configure Horizontal Timing VI.

LabVIEW VI	C/C++ Function Call
	<p>Call <code>niScope_Configure HorizontalTiming</code> with the following parameters:</p> <p>enforceRealtime: <code>NISCOPE_VAL_TRUE</code> numRecords: 1 vi: The instrument handle from <code>niScope_init</code> minSampleRate: 250,000,000 refPosition: 50.0 minNumPts: 300,000</p>

11. Repeat steps 11. a through 11. e for each *Input Frequency* in the current iteration.
 - a. Configure the calibrator to output the *Input Frequency* listed in Table 9 for the current iteration.
 - b. Wait 2,500 ms for the impedance matching and frequency of the calibrator to settle.

- c. Initiate a waveform acquisition using the niScope Initiate Acquisition VI.

LabVIEW VI	C/C++ Function Call
	<p>Call <code>niScope_Initiate Acquisition</code> with the following parameter:</p> <p>vi: The instrument handle from <code>niScope_init</code></p>

- d. Fetch a waveform from the digitizer and perform a voltage RMS measurement using the niScope Fetch Measurement (poly) VI. Select the Measurement Scalar DBL instance of the VI. This value is the *Measured RMS Voltage of Generated Sine Wave* used in step 11. e.

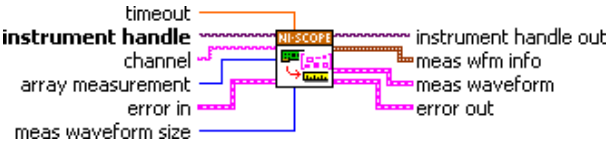
LabVIEW VI	C/C++ Function Call
	<p>Call <code>niScope_FetchMeasurement</code> with the following parameters:</p> <p>timeout: 1.0 vi: The instrument handle from <code>niScope_init</code> channelList: "0" scalarMeasFunction: <code>NISCOPE_VAL_VOLTAGE_RMS</code></p>

- e. Calculate the power difference using the following formula:

$$\text{power} = (20\log_{10} a) - (20\log_{10} b)$$

where

a is the *Measured RMS Voltage of Generated Sine Wave*

b is the *Measured RMS Voltage of 50 kHz Sine Wave*

If the result is within the test limits in Table 9, the device has passed this portion of the verification.

12. Repeat steps 2 through 11 for each iteration in Table 9.
13. Move the calibrator test head to the digitizer input channel 1 and repeat steps 2 through 12, changing the value of the **channelList** parameter from "0" to "1".

14. End the session using the niScope Close VI.

LabVIEW VI	C/C++ Function Call
	<p>Call <code>niScope_close</code> with the following parameter:</p> <p>vi: The instrument handle from <code>niScope_init</code></p>

You have finished verifying the bandwidth and flatness of the NI 5114.

Table 9. NI 5114 Bandwidth and Flatness Stimuli and Published Specifications

Iteration	Max Input Frequency (Hz)	Range (V)	Input Frequency (Hz)	Published Specifications	
				Max Level (dB)	Min Level (dB)
1	125 MHz	0.04	49,900,000	1	-1
			100,000,000	3	-3
2	125 MHz	0.4	49,900,000	1	-1
			125,000,000	3	-3
3	125 MHz	2	49,900,000	1	-1
			125,000,000	3	-3
4	125 MHz	10	50,100,000	1	-1
			125,000,000	3	-3
5	20 MHz	1	20,100,000	N/A	-3*
			25,100,000	-3 ¹	N/A

* Published specification value listed for validation of noise filter only. The specification is not included in the *NI PXI/PCI-5114 Specifications* document.

Trigger Sensitivity

Complete the following steps to verify the trigger sensitivity of the NI 5114. You must verify channel 0, channel 1, and the external trigger channel using the corresponding iterations listed in Table 10. Use the following inputs:

- For channel 0, use the entries for iterations 1 and 2.
 - For channel 1, use the entries for iterations 3 and 4.
 - For the external trigger channel, use the entries for iterations 5 and 6.
1. Open a session and obtain a session handle using the niScope Initialize VI.

LabVIEW VI	C/C++ Function Call
	<p>Call <code>niScope_init</code> with the following parameters:</p> <p>resourceName: The device name assigned by MAX idQuery: <code>VI_FALSE</code> resetDevice: <code>VI_TRUE</code></p>

2. Configure the input impedance and the maximum input frequency using the niScope Configure Chan Characteristics VI.

LabVIEW VI	C/C++ Function Call
	<p>Call <code>niScope_ConfigureChanCharacteristics</code> with the following parameters:</p> <p>vi: The instrument handle from <code>niScope_init</code> channelList: "0" inputImpedance: <code>NISCOPE_VAL_50_OHM</code> maxInputFrequency: <code>125,000,000</code></p>

- Configure the common vertical properties using the niScope Configure Vertical VI.

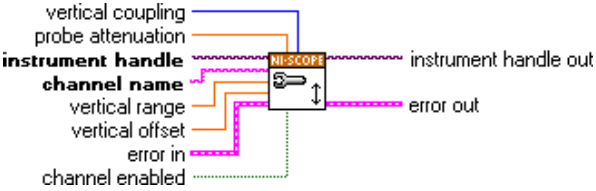
LabVIEW VI	C/C++ Function Call
	<p>Call <code>niScope_Configure Vertical</code> with the following parameters:</p> <p>coupling: <code>NISCOPE_VAL_DC</code> probeAttenuation: <code>1.0</code> vi: The instrument handle from <code>niScope_init</code> channelList: <code>"0"</code> range: <code>0.2</code> offset: <code>0.0</code> enabled: <code>NISCOPE_VAL_TRUE</code></p>

- Configure the horizontal properties using the niScope Configure Horizontal Timing VI.

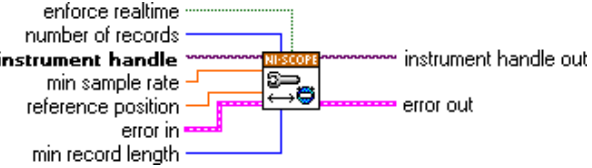
LabVIEW VI	C/C++ Function Call
	<p>Call <code>niScope_Configure HorizontalTiming</code> with the following parameters:</p> <p>enforceRealtime: <code>NISCOPE_VAL_TRUE</code> numRecords: <code>50</code> vi: The instrument handle from <code>niScope_init</code> minSampleRate: <code>250,000,000</code> refPosition: <code>50.0</code> minNumPts: <code>1,000</code></p>

- Configure an edge trigger using the niScope Configure Trigger (poly) VI. Select the Analog Edge Ref Trigger instance of the VI.

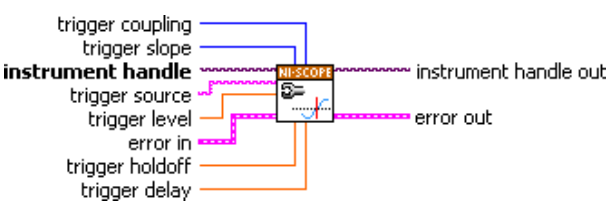
LabVIEW VI	C/C++ Function Call
	<p>Call <code>niScope_ConfigureTriggerEdge</code> with the following parameters:</p> <p>triggerCoupling: <code>NISCOPE_VAL_DC</code> slope: The <i>Slope</i> value in Table 10 for the current iteration vi: The instrument handle from <code>niScope_init</code> triggerSource: The <i>Trigger Source</i> value in Table 10 for the current iteration level: The <i>Level</i> value in Table 10 for the current iteration holdoff: 0 delay: 0</p>



Note The trigger level is set to center the trigger hysteresis window at 0.0 V.

- Commit all the parameter settings to hardware using the niScope Commit VI.

LabVIEW VI	C/C++ Function Call
	<p>Call <code>niScope_Commit</code> with the following parameter:</p> <p>vi: The instrument handle from <code>niScope_init</code></p>

- Connect the scope calibrator test head directly to the digitizer input for the channel you are testing. Configure the calibrator to output the appropriate signal in Table 10.
- Wait 2,500 ms for the impedance matching and frequency of the calibrator to settle.

- Initiate a waveform acquisition using the niScope Initiate Acquisition VI.

LabVIEW VI	C/C++ Function Call
	<p>Call <code>niScope_Initiate Acquisition</code> with the following parameter:</p> <p>vi: The instrument handle from <code>niScope_init</code></p>

- Acquire a waveform using the niScope Fetch (poly) VI. Select the Cluster instance of the VI.

LabVIEW VI	C/C++ Function Call
	<p>Call <code>niScope_Fetch</code> with the following parameter:</p> <p>timeout: 2.0 vi: The instrument handle from <code>niScope_init</code> channelList: "0" numSamples: -1</p>

- If the digitizer does not time out, the digitizer has passed this portion of the verification. If the digitizer does time out, you must call the niScope Abort VI to end the acquisition.

LabVIEW VI	C/C++ Function Call
	<p>Call <code>niScope_Abort</code> with the following parameter:</p> <p>vi: The instrument handle from <code>niScope_init</code></p>

- To verify the trigger sensitivity on channel 1, repeat steps 2 through 11 using the values in Table 10, iterations 3 and 4. Make the following changes:
 - Change **channelList** to "1" in steps 2, 3, and 10.
 - Connect the calibrator test head to channel 1 in step 7.

13. To verify the trigger sensitivity on the external trigger channel, repeat steps 2 through 11 using the values in Table 10, iterations 5 and 6. Make the following changes:
 - Change **channelList** to "0" in steps 2, 3, and 10.
 - Connect the calibrator test head to the external trigger channel (TRIG) in step 7.
14. End the session using the niScope Close VI.

LabVIEW VI	C/C++ Function Call
	<p>Call <code>niScope_close</code> with the following parameter:</p> <p>vi: The instrument handle from <code>niScope_init</code></p>

You have finished verifying the trigger sensitivity for the NI 5114.

Table 10. NI 5114 Trigger Sensitivity Inputs

Iteration	Trigger Source	Level	Slope	Calibrator Signal
1	0	1 mV	NISCOPE_VAL_POSITIVE	9.7 mV _{pk-pk} 100 MHz sine wave with 50 Ω load impedance
2	0	-1 mV	NISCOPE_VAL_NEGATIVE	
3	1	1 mV	NISCOPE_VAL_POSITIVE	9.7 mV _{pk-pk} 100 MHz sine wave with 50 Ω load impedance
4	1	-1 mV	NISCOPE_VAL_NEGATIVE	
5	VAL_EXTERNAL	50 mV	NISCOPE_VAL_POSITIVE	485 mV _{pk-pk} 125 MHz sine wave with 1 MΩ load impedance
6	VAL_EXTERNAL	-50 mV	NISCOPE_VAL_NEGATIVE	

Adjustment

If the NI 5114 successfully passed each of the verification procedures within the calibration test limits, then an adjustment is recommended but not required to guarantee the published specifications for the next two years. If the digitizer was not within the calibration test limits for each of the verification procedures, you can perform the adjustment procedure to improve the accuracy of the digitizer. Refer to the [Appendix A: Calibration Options](#) section to determine which procedures to perform.

An adjustment is required only once every two years. Following the adjustment procedure automatically updates the calibration date and temperature in the EEPROM of the digitizer.



Note If the digitizer passed the entire verification procedure within the calibration test limits and you do not want to perform an adjustment, you can update the calibration date and onboard calibration temperature without making any adjustments by completing *only* steps 1 and 14 in this section.

Complete all of the following steps to externally adjust the NI 5114:

1. Obtain an instrument session handle using the niScope Cal Start VI.

LabVIEW VI	C/C++ Function Call
	<p>Call <code>niScope_CalStart</code> with the following parameters:</p> <p>resourceName: The name of the device to calibrate. You can find this name under Devices and Interfaces in MAX.</p> <p>password: The password required to open an external calibration session. If this password has not been changed since manufacturing, the password is "NI".</p>

2. Short-circuit the channel 0 input of the digitizer by connecting the calibrator test head directly to the digitizer and grounding the output of the calibrator.
3. Wait 2,500 ms for the impedance matching and frequency of the calibrator to settle.

- Adjust the vertical range using the niScope Cal Adjust Range VI.

LabVIEW VI	C/C++ Function Call
	<p>Call <code>niScope_CalAdjust Range</code> with the following parameters:</p> <p>sessionHandle: The instrument handle from <code>niScope_CalStart</code></p> <p>channelName: "0"</p> <p>range: 10</p> <p>stimulus: 0</p>

- Configure the calibrator to output the voltage listed under the *Input (V)* column in Table 11. Configure the load impedance of the calibrator to 1 M Ω .
- Wait 2,500 ms for the impedance matching and frequency of the calibrator to settle.
- Adjust the vertical range using the niScope Cal Adjust Range VI.

LabVIEW VI	C/C++ Function Call
	<p>Call <code>niScope_CalAdjust Range</code> with the following parameters:</p> <p>sessionHandle: The instrument handle from <code>niScope_CalStart</code></p> <p>channelName: "0"</p> <p>range: The <i>Range</i> value in Table 11 for the current iteration</p> <p>stimulus: The <i>Input voltage</i> in Table 11 for the current iteration</p>

- Repeat steps 5 through 7 for each iteration in Table 11.
- Move the calibrator test head to the digitizer input channel 1 and repeat steps 2 through 8, changing the value of the **channelList** parameter from "0" to "1".
- Using a BNC cable, connect REF FREQUENCY OUTPUT on the back of the calibrator to the channel 0 input of the digitizer. Make sure the output of the reference frequency is enabled and set to 10 MHz. If you are not using a Fluke 9500B/Wavetek 9500 calibrator, connect a precise 10 MHz, 1 V_{pk-pk} sine or square wave source to channel 0.

11. Adjust the sample rate using the niScope Cal Adjust VCXO VI.

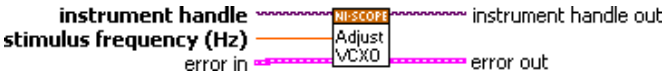
LabVIEW VI	C/C++ Function Call
	<p>Call <code>niScope_CalAdjustVCXO</code> with the following parameters:</p> <p>sessionHandle: The instrument handle from <code>niScope_CalStart</code></p> <p>stimulusFreq: 10,000,000</p>



Note The 10 MHz stimulus is automatically taken from channel 0.

12. Disconnect or disable all inputs to the digitizer.

13. Self-calibrate the digitizer using niScope Cal Self Calibrate VI.

LabVIEW VI	C/C++ Function Call
	<p>Call <code>niScope_CalSelfCalibrate</code> with the following parameters:</p> <p>sessionHandle: The instrument handle from <code>niScope_CalStart</code></p> <p>channelList: <code>VI_NULL</code></p> <p>option: <code>VI_NULL</code></p>

14. End the session and save the results using the niScope Cal End VI.

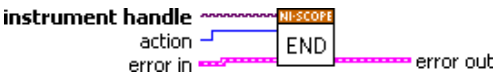
LabVIEW VI	C/C++ Function Call
	<p>Call <code>niScope_CalEnd</code> with the following parameters:</p> <p>sessionHandle: The instrument handle from <code>niScope_CalStart</code></p> <p>action: <code>NISCOPE_VAL_ACTION_STORE</code></p>

You have finished adjusting the NI 5114. Repeat the steps listed in the [Verification](#) section to reverify the performance of the NI 5114 after adjustments.

Table 11. NI 5114 Input Parameters for External Adjustment

Iteration	Range (V)	Input (V)
1	40	18
2	20	9
3	10	4.5
4	4	1.8
5	2	0.9
6	1	0.45
7	0.4	0.18
8	0.2	0.09
9	0.1	0.045
10	0.04	0.018
11	40	-18
12	20	-9
13	10	-4.5
14	4	-1.8
15	2	-0.9
16	1	-0.45
17	0.4	-0.18
18	0.2	-0.09
19	0.1	-0.045
20	0.04	-0.018

Appendix A: Calibration Options

External calibration involves verification and if necessary, adjustment and reverification. Adjustment is the process of measuring and compensating for device performance to improve the measurement accuracy. Performing an adjustment updates the calibration date, effectively resetting the calibration interval. The device is guaranteed to meet or exceed its published specifications for the duration of the calibration interval. Verification is the process of testing the device to ensure that the measurement accuracy is within certain specifications. Verification can be used to ensure that the adjustment process was successful or to determine if the adjustment process needs to be performed at all. During verification, you must compare the measurement error to the limits given in each section.

This document provides two sets of test limits for most verification stages—the *calibration test limits* and the *published specifications*. The calibration test limits are more restrictive than the published specifications. If all of the measurement errors determined during verification fall within the calibration test limits, the device is guaranteed to meet or exceed its published specifications for a full calibration interval (two years). For this reason, you must verify against the calibration test limits when performing verification after adjustment. If all of the measurement errors determined during verification fall within the published specifications, but not within the calibration test limits, the device is meeting its published specifications. While the device does not necessarily remain within these specifications for an additional two years, it will meet published specifications for the remainder of the current calibration interval. In this case, you can perform an adjustment if you want to further improve the measurement accuracy or reset the calibration interval. If some measurement errors determined during verification do not fall within the published specifications, you must perform an adjustment to restore the device operation to its published specifications.

The *Complete Calibration* section describes the recommended calibration procedure. The *Optional Calibration* section describes alternative procedures that allow you to skip adjustment if the device already meets its calibration test limits or published specifications.

Complete Calibration

Perform a complete calibration to guarantee that the NI 5114 meets or exceeds its published specifications for a two-year calibration interval. At the end of the complete calibration procedure, verify that the measurement error falls within the calibration test limits. Figure 1 shows the programming flow for a complete calibration.

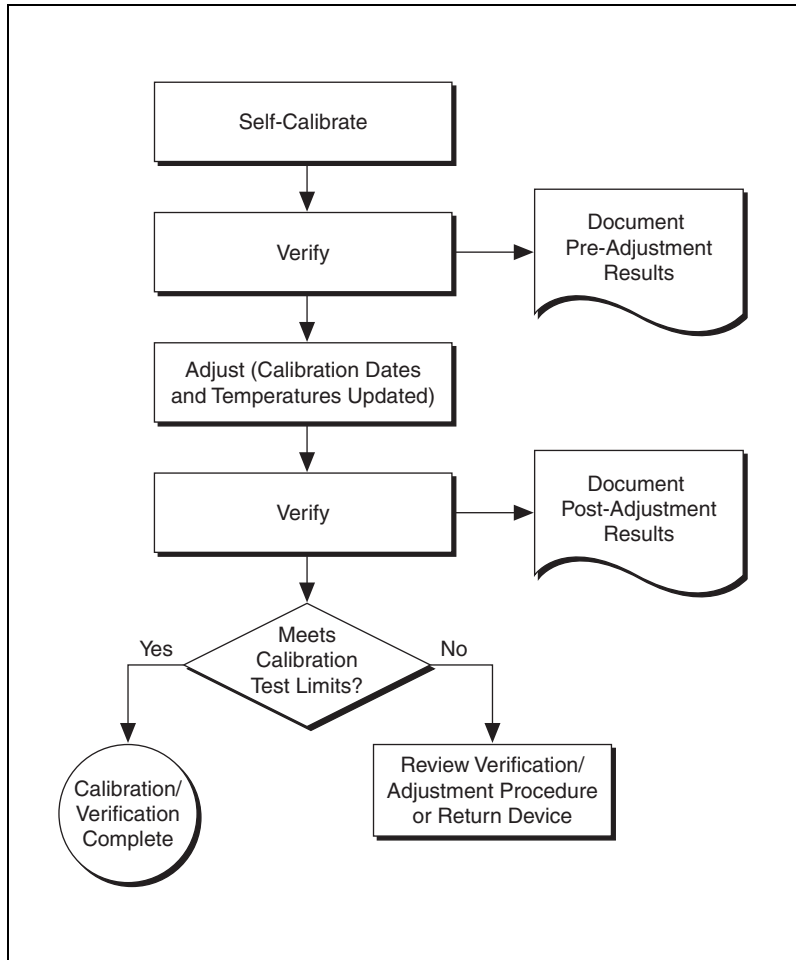

Figure 1. Complete Calibration Programming Flow

Optional Calibration

You can choose to skip the adjustment steps of the calibration procedure if the measurement error is within the calibration test limits or the published specifications during the first verification. If all of the measurement errors determined during the first verification fall within the calibration test limits, the device is guaranteed to meet or exceed its published specifications for a full calibration interval. In this case, you can update the calibration date, effectively resetting the calibration interval, without actually performing an adjustment. Refer to the [Adjustment](#) section for more information.

If all of the measurement errors determined during the first verification fall within the published specifications, but not within the calibration test limits, adjustment is also optional. However, you cannot update the calibration date because the device will not necessarily operate within the published specifications for an additional two years.



Note Regardless of the results of the first verification, if you choose to perform an adjustment, you must verify that the measurement error falls within the calibration test limits at the end of the calibration procedure.

Figure 2 shows the programming flow for the optional calibration.

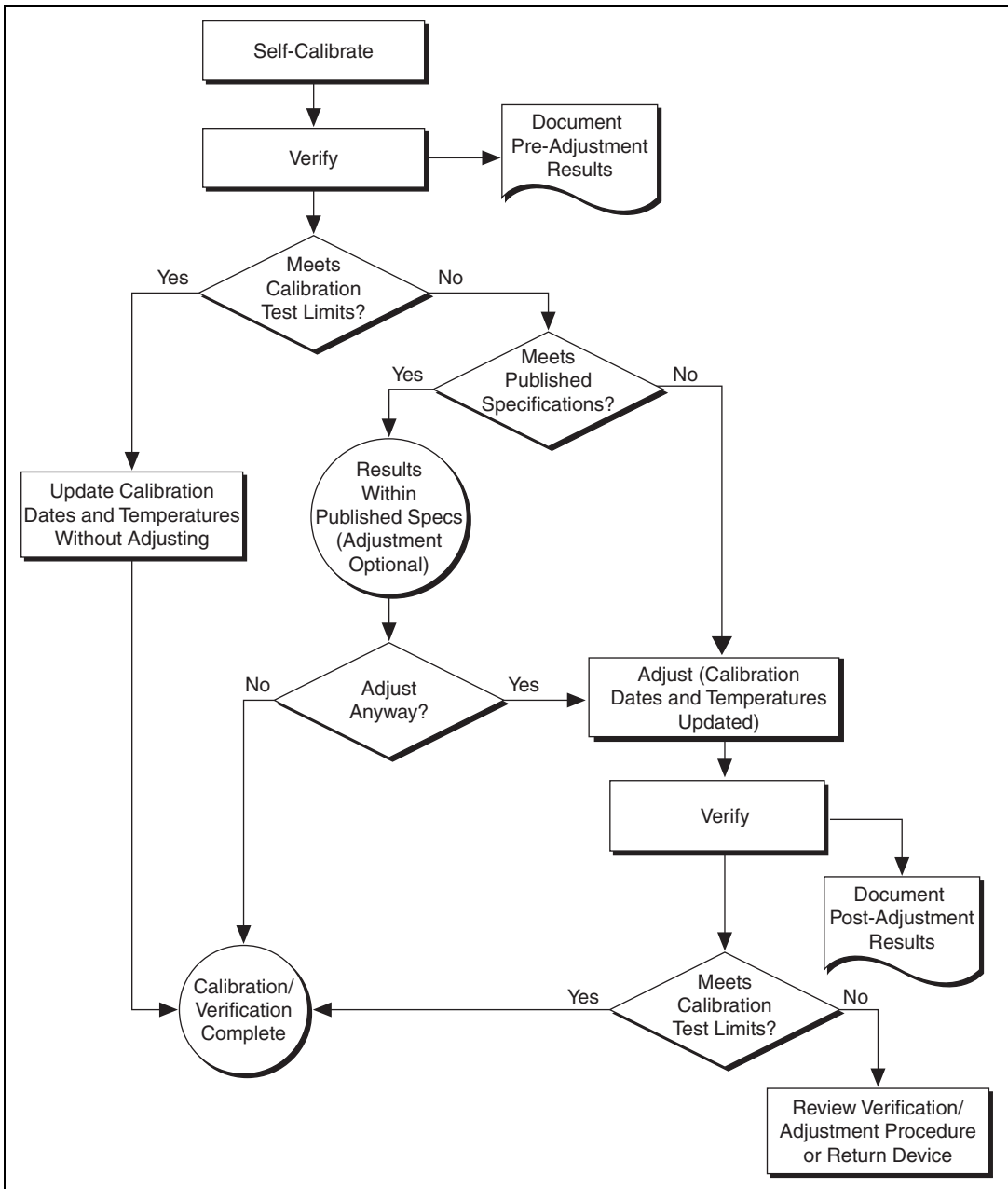

Figure 2. Optional Calibration Programming Flow

Appendix B: Calibration Utilities

NI-SCOPE supports several calibration utilities you can use to retrieve information about adjustments performed on the NI 5114, change the external calibration password, and store small amounts of information in the onboard EEPROM. Although you can retrieve some data using MAX, you can retrieve all the data programmatically using NI-SCOPE functions.

MAX

To retrieve data using MAX, complete the following steps:

1. Select the device from which you want to retrieve information from **My System»Devices and Interfaces»NI-DAQmx Devices**.
2. Select the **Calibration** tab in the lower right corner.

You should see information about the last date and temperature for both external and self-calibration.

NI-SCOPE

NI-SCOPE provides a full complement of calibration utility functions and VIs. Refer to the *NI High-Speed Digitizers Help* for the complete function reference and VI reference. The utility functions include:

- `niScope_CalChangePassword` (niScope Cal Change Password VI)
- `niScope_CalFetchCount` (niScope Cal Fetch Count VI)
- `niScope_CalFetchDate` (niScope Cal Fetch Date VI)
- `niScope_CalFetchMiscInfo` (niScope Cal Fetch Misc Info VI)
- `niScope_CalFetchTemperature` (niScope Cal Fetch Temperature VI)
- `niScope_CalStoreMiscInfo` (niScope Cal Store Misc Info VI)

Where to Go for Support

The National Instruments Web site is your complete resource for technical support. At ni.com/support you have access to everything from troubleshooting and application development self-help resources to email and phone assistance from NI Application Engineers.

A Declaration of Conformity (DoC) is our claim of compliance with the Council of the European Communities using the manufacturer's declaration of conformity. This system affords the user protection for electronic compatibility (EMC) and product safety. You can obtain the DoC for your product by visiting ni.com/certification. If your product supports calibration, you can obtain the calibration certificate for your product at ni.com/calibration.

National Instruments corporate headquarters is located at 11500 North Mopac Expressway, Austin, Texas, 78759-3504. National Instruments also has offices located around the world to help address your support needs. For telephone support in the United States, create your service request at ni.com/support and follow the calling instructions or dial 512 795 8248. For telephone support outside the United States, contact your local branch office:

Australia 1800 300 800, Austria 43 662 457990-0,
Belgium 32 (0) 2 757 0020, Brazil 55 11 3262 3599,
Canada 800 433 3488, China 86 21 5050 9800,
Czech Republic 420 224 235 774, Denmark 45 45 76 26 00,
Finland 385 (0) 9 725 72511, France 01 57 66 24 24,
Germany 49 89 7413130, India 91 80 41190000, Israel 972 3 6393737,
Italy 39 02 413091, Japan 81 3 5472 2970, Korea 82 02 3451 3400,
Lebanon 961 (0) 1 33 28 28, Malaysia 1800 887710,
Mexico 01 800 010 0793, Netherlands 31 (0) 348 433 466,
New Zealand 0800 553 322, Norway 47 (0) 66 90 76 60,
Poland 48 22 3390150, Portugal 351 210 311 210, Russia 7 495 783 6851,
Singapore 1800 226 5886, Slovenia 386 3 425 42 00,
South Africa 27 0 11 805 8197, Spain 34 91 640 0085,
Sweden 46 (0) 8 587 895 00, Switzerland 41 56 2005151,
Taiwan 886 02 2377 2222, Thailand 662 278 6777,
Turkey 90 212 279 3031, United Kingdom 44 (0) 1635 523545

National Instruments, NI, ni.com, and LabVIEW are trademarks of National Instruments Corporation. Refer to the *Terms of Use* section on ni.com/legal for more information about National Instruments trademarks. Other product and company names mentioned herein are trademarks or trade names of their respective companies. For patents covering National Instruments products, refer to the appropriate location: **Help»Patents** in your software, the `patents.txt` file on your CD, or ni.com/patents.