

# NI Vision

## NI PCI-8254R User Manual

*1394a Image Acquisition Device with Reconfigurable I/O*

## Worldwide Technical Support and Product Information

ni.com

### National Instruments Corporate Headquarters

11500 North Mopac Expressway Austin, Texas 78759-3504 USA Tel: 512 683 0100

### Worldwide Offices

Australia 1800 300 800, Austria 43 0 662 45 79 90 0, Belgium 32 0 2 757 00 20, Brazil 55 11 3262 3599,  
Canada 800 433 3488, China 86 21 6555 7838, Czech Republic 420 224 235 774, Denmark 45 45 76 26 00,  
Finland 385 0 9 725 725 11, France 33 0 1 48 14 24 24, Germany 49 0 89 741 31 30, India 91 80 41190000,  
Israel 972 0 3 6393737, Italy 39 02 413091, Japan 81 3 5472 2970, Korea 82 02 3451 3400,  
Lebanon 961 0 1 33 28 28, Malaysia 1800 887710, Mexico 01 800 010 0793, Netherlands 31 0 348 433 466,  
New Zealand 0800 553 322, Norway 47 0 66 90 76 60, Poland 48 22 3390150, Portugal 351 210 311 210,  
Russia 7 095 783 68 51, Singapore 1800 226 5886, Slovenia 386 3 425 4200, South Africa 27 0 11 805 8197,  
Spain 34 91 640 0085, Sweden 46 0 8 587 895 00, Switzerland 41 56 200 51 51, Taiwan 886 02 2377 2222,  
Thailand 662 278 6777, United Kingdom 44 0 1635 523545

For further support information, refer to the *Technical Support and Professional Services* appendix. To comment on National Instruments documentation, refer to the National Instruments Web site at [ni.com/info](http://ni.com/info) and enter the info code `feedback`.

# Important Information

---

## Warranty

The NI PCI-8254R is warranted against defects in materials and workmanship for a period of one year from the date of shipment, as evidenced by receipts or other documentation. National Instruments will, at its option, repair or replace equipment that proves to be defective during the warranty period. This warranty includes parts and labor.

The media on which you receive National Instruments software are warranted not to fail to execute programming instructions, due to defects in materials and workmanship, for a period of 90 days from date of shipment, as evidenced by receipts or other documentation. National Instruments will, at its option, repair or replace software media that do not execute programming instructions if National Instruments receives notice of such defects during the warranty period. National Instruments does not warrant that the operation of the software shall be uninterrupted or error free.

A Return Material Authorization (RMA) number must be obtained from the factory and clearly marked on the outside of the package before any equipment will be accepted for warranty work. National Instruments will pay the shipping costs of returning to the owner parts which are covered by warranty.

National Instruments believes that the information in this document is accurate. The document has been carefully reviewed for technical accuracy. In the event that technical or typographical errors exist, National Instruments reserves the right to make changes to subsequent editions of this document without prior notice to holders of this edition. The reader should consult National Instruments if errors are suspected. In no event shall National Instruments be liable for any damages arising out of or related to this document or the information contained in it.

EXCEPT AS SPECIFIED HEREIN, NATIONAL INSTRUMENTS MAKES NO WARRANTIES, EXPRESS OR IMPLIED, AND SPECIFICALLY DISCLAIMS ANY WARRANTY OF MERCHANTABILITY OR FITNESS FOR A PARTICULAR PURPOSE. CUSTOMER'S RIGHT TO RECOVER DAMAGES CAUSED BY FAULT OR NEGLIGENCE ON THE PART OF NATIONAL INSTRUMENTS SHALL BE LIMITED TO THE AMOUNT THEREOF PAID BY THE CUSTOMER. NATIONAL INSTRUMENTS WILL NOT BE LIABLE FOR DAMAGES RESULTING FROM LOSS OF DATA, PROFITS, USE OF PRODUCTS, OR INCIDENTAL OR CONSEQUENTIAL DAMAGES, EVEN IF ADVISED OF THE POSSIBILITY THEREOF. This limitation of the liability of National Instruments will apply regardless of the form of action, whether in contract or tort, including negligence. Any action against National Instruments must be brought within one year after the cause of action accrues. National Instruments shall not be liable for any delay in performance due to causes beyond its reasonable control. The warranty provided herein does not cover damages, defects, malfunctions, or service failures caused by owner's failure to follow the National Instruments installation, operation, or maintenance instructions; owner's modification of the product; owner's abuse, misuse, or negligent acts; and power failure or surges, fire, flood, accident, actions of third parties, or other events outside reasonable control.

## Copyright

Under the copyright laws, this publication may not be reproduced or transmitted in any form, electronic or mechanical, including photocopying, recording, storing in an information retrieval system, or translating, in whole or in part, without the prior written consent of National Instruments Corporation.

National Instruments respects the intellectual property of others, and we ask our users to do the same. NI software is protected by copyright and other intellectual property laws. Where NI software may be used to reproduce software or other materials belonging to others, you may use NI software only to reproduce materials that you may reproduce in accordance with the terms of any applicable license or other legal restriction.

## Trademarks

National Instruments, NI, ni.com, and LabVIEW are trademarks of National Instruments Corporation. Refer to the *Terms of Use* section on [ni.com/legal](http://ni.com/legal) for more information about National Instruments trademarks.

FireWire® is the registered trademark of Apple Computer, Inc. Other product and company names mentioned herein are trademarks or trade names of their respective companies.

Members of the National Instruments Alliance Partner Program are business entities independent from National Instruments and have no agency, partnership, or joint-venture relationship with National Instruments.

## Patents

For patents covering National Instruments products, refer to the appropriate location: **Help»Patents** in your software, the `patents.txt` file on your CD, or [ni.com/patents](http://ni.com/patents).

## WARNING REGARDING USE OF NATIONAL INSTRUMENTS PRODUCTS

(1) NATIONAL INSTRUMENTS PRODUCTS ARE NOT DESIGNED WITH COMPONENTS AND TESTING FOR A LEVEL OF RELIABILITY SUITABLE FOR USE IN OR IN CONNECTION WITH SURGICAL IMPLANTS OR AS CRITICAL COMPONENTS IN ANY LIFE SUPPORT SYSTEMS WHOSE FAILURE TO PERFORM CAN REASONABLY BE EXPECTED TO CAUSE SIGNIFICANT INJURY TO A HUMAN.

(2) IN ANY APPLICATION, INCLUDING THE ABOVE, RELIABILITY OF OPERATION OF THE SOFTWARE PRODUCTS CAN BE IMPAIRED BY ADVERSE FACTORS, INCLUDING BUT NOT LIMITED TO FLUCTUATIONS IN ELECTRICAL POWER SUPPLY, COMPUTER HARDWARE MALFUNCTIONS, COMPUTER OPERATING SYSTEM SOFTWARE FITNESS, FITNESS OF COMPILERS AND DEVELOPMENT SOFTWARE USED TO DEVELOP AN APPLICATION, INSTALLATION ERRORS, SOFTWARE AND HARDWARE COMPATIBILITY PROBLEMS, MALFUNCTIONS OR FAILURES OF ELECTRONIC MONITORING OR CONTROL DEVICES, TRANSIENT FAILURES OF ELECTRONIC SYSTEMS (HARDWARE AND/OR SOFTWARE), UNANTICIPATED USES OR MISUSES, OR ERRORS ON THE PART OF THE USER OR APPLICATIONS DESIGNER (ADVERSE FACTORS SUCH AS THESE ARE HEREAFTER COLLECTIVELY TERMED "SYSTEM FAILURES"). ANY APPLICATION WHERE A SYSTEM FAILURE WOULD CREATE A RISK OF HARM TO PROPERTY OR PERSONS (INCLUDING THE RISK OF BODILY INJURY AND DEATH) SHOULD NOT BE RELIANT SOLELY UPON ONE FORM OF ELECTRONIC SYSTEM DUE TO THE RISK OF SYSTEM FAILURE. TO AVOID DAMAGE, INJURY, OR DEATH, THE USER OR APPLICATION DESIGNER MUST TAKE REASONABLY PRUDENT STEPS TO PROTECT AGAINST SYSTEM FAILURES, INCLUDING BUT NOT LIMITED TO BACK-UP OR SHUT DOWN MECHANISMS. BECAUSE EACH END-USER SYSTEM IS CUSTOMIZED AND DIFFERS FROM NATIONAL INSTRUMENTS' TESTING PLATFORMS AND BECAUSE A USER OR APPLICATION DESIGNER MAY USE NATIONAL INSTRUMENTS PRODUCTS IN COMBINATION WITH OTHER PRODUCTS IN A MANNER NOT EVALUATED OR CONTEMPLATED BY NATIONAL INSTRUMENTS, THE USER OR APPLICATION DESIGNER IS ULTIMATELY RESPONSIBLE FOR VERIFYING AND VALIDATING THE SUITABILITY OF NATIONAL INSTRUMENTS PRODUCTS WHENEVER NATIONAL INSTRUMENTS PRODUCTS ARE INCORPORATED IN A SYSTEM OR APPLICATION, INCLUDING, WITHOUT LIMITATION, THE APPROPRIATE DESIGN, PROCESS AND SAFETY LEVEL OF SUCH SYSTEM OR APPLICATION.

# Compliance

---

## Compliance with FCC/Canada Radio Frequency Interference Regulations

### Determining FCC Class

The Federal Communications Commission (FCC) has rules to protect wireless communications from interference. The FCC places digital electronics into two classes. These classes are known as Class A (for use in industrial-commercial locations only) or Class B (for use in residential or commercial locations). All National Instruments (NI) products are FCC Class A products.

Depending on where it is operated, this Class A product could be subject to restrictions in the FCC rules. (In Canada, the Department of Communications (DOC), of Industry Canada, regulates wireless interference in much the same way.) Digital electronics emit weak signals during normal operation that can affect radio, television, or other wireless products.

All Class A products display a simple warning statement of one paragraph in length regarding interference and undesired operation. The FCC rules have restrictions regarding the locations where FCC Class A products can be operated.

Consult the FCC Web site at [www.fcc.gov](http://www.fcc.gov) for more information.

### FCC/DOC Warnings

This equipment generates and uses radio frequency energy and, if not installed and used in strict accordance with the instructions in this manual and the CE marking Declaration of Conformity\*, may cause interference to radio and television reception. Classification requirements are the same for the Federal Communications Commission (FCC) and the Canadian Department of Communications (DOC).

Changes or modifications not expressly approved by NI could void the user's authority to operate the equipment under the FCC Rules.

### Class A

#### Federal Communications Commission

This equipment has been tested and found to comply with the limits for a Class A digital device, pursuant to part 15 of the FCC Rules. These limits are designed to provide reasonable protection against harmful interference when the equipment is operated in a commercial environment. This equipment generates, uses, and can radiate radio frequency energy and, if not installed and used in accordance with the instruction manual, may cause harmful interference to radio communications. Operation of this equipment in a residential area is likely to cause harmful interference in which case the user is required to correct the interference at their own expense.

#### Canadian Department of Communications

This Class A digital apparatus meets all requirements of the Canadian Interference-Causing Equipment Regulations.

Cet appareil numérique de la classe A respecte toutes les exigences du Règlement sur le matériel brouilleur du Canada.

### Compliance with EU Directives

Users in the European Union (EU) should refer to the Declaration of Conformity (DoC) for information\* pertaining to the CE marking. Refer to the Declaration of Conformity (DoC) for this product for any additional regulatory compliance information. To obtain the DoC for this product, visit [ni.com/certification](http://ni.com/certification), search by model number or product line, and click the appropriate link in the Certification column.

\* The CE marking Declaration of Conformity contains important supplementary information and instructions for the user or installer.

# Conventions

---

The following conventions are used in this manual:

»

The » symbol leads you through nested menu items and dialog box options to a final action. The sequence **File»Page Setup»Options** directs you to pull down the **File** menu, select the **Page Setup** item, and select **Options** from the last dialog box.



This icon denotes a note, which alerts you to important information.



This icon denotes a caution, which advises you of precautions to take to avoid injury, data loss, or a system crash.



When symbol is marked on a product, it denotes a warning advising you to take precautions to avoid electrical shock.

**bold**

Bold text denotes items that you must select or click in the software, such as menu items and dialog box options. Bold text also denotes parameter names.

*italic*

Italic text denotes variables, emphasis, a cross-reference, or an introduction to a key concept. Italic text also denotes text that is a placeholder for a word or value that you must supply.

`monospace`

Text in this font denotes text or characters that you should enter from the keyboard, sections of code, programming examples, and syntax examples. This font is also used for the proper names of disk drives, paths, directories, programs, subprograms, subroutines, device names, functions, operations, variables, filenames, and extensions.

# Contents

---

## Chapter 1

### Introduction

Software Overview .....	1-1
Vision Builder for Automated Inspection .....	1-2
Vision Development Module .....	1-2
IEEE 1394 and NI 8254R .....	1-3
Functional Overview.....	1-3
Start Conditions .....	1-4
Acquisition Window Control.....	1-4

## Chapter 2

### Digital I/O

RIO and LabVIEW FPGA.....	2-1
TTL Inputs and Outputs.....	2-2
Isolated Inputs and Outputs .....	2-3
I/O for Normal Operation .....	2-4
Trigger Inputs .....	2-5
Timed Pulse Output.....	2-5
Initiating a Timed Pulse .....	2-5
Pulse Modes .....	2-6
Pulse Delay .....	2-6
Pulse Width .....	2-7
Trigger Polarity .....	2-7
Trigger Change Detectors.....	2-8
Quadrature Encoder.....	2-8
Product Selection Port .....	2-8
Using ISO Input 5 as a Latch .....	2-9
General-Purpose I/O.....	2-9
General-Purpose Inputs.....	2-9
General-Purpose Outputs .....	2-10
I/O for Fault Conditions .....	2-10
Shutdown .....	2-11
Watchdog Timer .....	2-11
Considerations When Connecting the Digital I/O .....	2-12
Wiring an Isolated Input to a Sourcing Output Device .....	2-12
Wiring an Isolated Output to an External Load.....	2-13
Protecting Inductive Loads.....	2-14
Transmission Line Effects.....	2-15

## Chapter 3 Signal Connections

Connectors .....	3-2
2-Position Isolated Outputs Power Connector .....	3-2
IEEE 1394a Connector .....	3-3
General-Purpose Digital I/O .....	3-3
Cabling .....	3-8
IEEE 1394 Camera Cables .....	3-8
I/O Terminal Block .....	3-9
NI Vision I/O Terminal Block and Prototyping Accessory .....	3-9
Power Requirements .....	3-9
Isolated Outputs Power Connector .....	3-9

## Appendix A Technical Support and Professional Services

### Glossary

### Index

---

# Introduction

The National Instruments PCI-8254R is an IEEE 1394a interface device for PCI with reconfigurable I/O (RIO). The NI 8254R is OHCI compliant and should be used with IEEE 1394a devices that run natively in Windows 2000/XP.

The NI 8254R device ships with documentation and NI Vision Acquisition Software, which contains all of the drivers in the NI Vision product line. With NI Vision Acquisition Software, you can quickly and easily start your applications without having to program the device at the register level.

The NI 8254R includes TTL inputs and outputs for triggering, and isolated inputs and outputs for connecting to external devices, such as lighting controllers, proximity sensors, and quadrature encoders.

Behind the digital I/O of the NI 8254R is an FPGA which has been preconfigured with the functionality required for most common machine vision tasks. However, if the factory configured functionality does not fulfill your requirements, the FPGA is user configurable with the LabVIEW FPGA Module. The NI 8254R provides a convenient 44-pin D-SUB connector on its front panel to access its digital I/O.

For detailed specifications of the NI 8254R, refer to the *Specifications* section of *NI PCI-8254R Quick Start Guide*.

---

## Software Overview

Programming the NI 8254R requires two drivers to control the hardware: NI-IMAQdx and NI-IMAQ I/O. Both drivers are included with NI Vision Acquisition Software 8.2.1 or later.

NI-IMAQdx has an extensive library of functions you can call from the application development environment (ADE) and handles many of the complex issues between the computer and the image acquisition device, such as programming interrupts and camera control. NI-IMAQ I/O provides functions you can call from the ADE and controls the I/O functionality for the NI 8254R.

National Instruments also offers the following application software packages for analyzing and processing your acquired images. For detailed information about individual software packages, refer to the documentation specific to each package.

## Vision Builder for Automated Inspection

NI Vision Builder for Automated Inspection (Vision Builder AI) is configurable machine vision software that you can use to prototype, benchmark, and deploy applications. Vision Builder AI does not require programming, but is scalable to powerful programming environments.

Vision Builder AI allows you to easily configure and benchmark a sequence of visual inspection steps, as well as deploy the visual inspection system for automated inspection. With Vision Builder AI, you can perform powerful visual inspection tasks and make decisions based on the results of individual tasks. You also can migrate the configured inspection to LabVIEW, extending the capabilities of the applications if necessary.

## Vision Development Module

NI Vision Development Module, which consists of NI Vision and NI Vision Assistant, is an image acquisition, processing, and analysis library of more than 270 functions for the following common machine vision tasks:

- Pattern matching
- Particle analysis
- Gauging
- Taking measurements
- Grayscale, color, and binary image display

You can use the Vision Development Module functions individually or in combination. With the Vision Development Module, you can acquire, display, and store images, as well as perform image analysis and processing. Using the Vision Development Module, imaging novices and experts can program the most basic or complicated image applications without knowledge of particular algorithm implementations.

As a part of the Vision Development Module, NI Vision Assistant is an interactive prototyping tool for machine vision and scientific imaging developers. With Vision Assistant, you can prototype vision applications quickly and test how various image processing functions work.

Vision Assistant generates a Builder file, which is a text description containing a recipe of the machine vision and image processing functions. This Builder file provides a guide you can use for developing applications in any ADE, such as LabWindows™/CVI™ or Visual Basic, using the Vision Assistant machine vision and image processing libraries. Using the LabVIEW VI creation wizard, Vision Assistant can create LabVIEW VI diagrams that perform the prototype you created in Vision Assistant. You can then use LabVIEW to add functionality to the generated VI.

## IEEE 1394 and NI 8254R

---

The NI 8254R uses FireWire® (IEEE 1394) technology, compatible with more than 50 machine vision grade cameras. FireWire is a cross-platform implementation of the high-speed serial data bus—defined by the IEEE 1394-1995 and IEEE 1394a-2000—that can move large amounts of data between computers and peripheral devices. It features simplified cabling via twisted pairs, hot swapping, and transfer speeds of up to 400 megabits per second. You can support up to 63 devices on the high speed bus with IEEE 1394.

The IEEE 1394a standard offers up to 400 Mb/s bandwidth. The NI 8254R provides two direct-connect IEEE 1394a ports, but more IEEE 1394 devices can be added with the addition of IEEE 1394 hubs. The NI 8254R can acquire images from IEEE 1394 cameras conforming to the *IIDC 1394-based Digital Camera Specification, Version 1.30* and higher.

The IEEE 1394 bus provides a fixed amount of bandwidth that is shared between the two IEEE 1394a ports on the NI 8254R. These ports provide direct connection for up to two DCAM-compliant IEEE 1394 cameras, depending on the amount of bandwidth each camera requires. Higher frame rates and larger image sizes require a higher data transfer rate and use more bandwidth.

## Functional Overview

---

The NI 8254R features a flexible, high-speed data path optimized for receiving and formatting video data from IEEE 1394 cameras.

The following block diagram illustrates the key functional components of the NI 8254R.

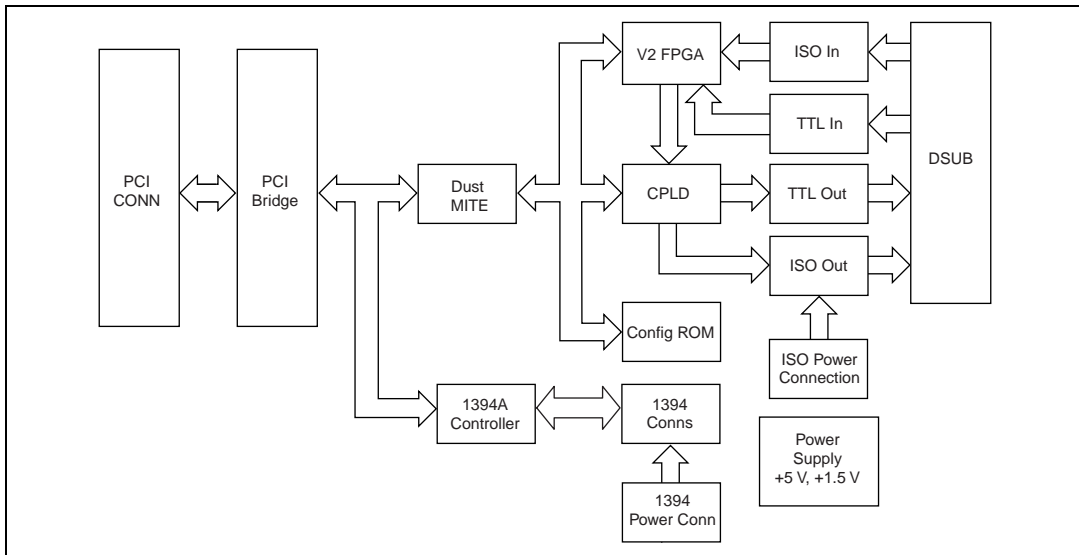

Figure 1-1. NI 8254R Block Diagram

## Start Conditions

The NI 8254R can start acquisitions in the following ways:

- **Software control**—The NI 8254R supports software control of acquisition start. You can configure the NI 8254R to capture a fixed number of frames. Use this configuration for capturing a single frame or a sequence of frames.
- **Trigger control**—You can start an acquisition by enabling external trigger lines. Each of these inputs can start a video acquisition on a rising or falling edge.

## Acquisition Window Control

You can configure the following parameter on the NI 8254R to control the video acquisition window:

- **Acquisition window**—The NI 8254R and the *IIDC 1394-based Digital Camera Specification* allow you to specify a particular region of active pixels and lines on a camera to acquire. In many cases, specifying a smaller acquisition window will increase the maximum frame rate of the camera. Valid acquisition windows, and their corresponding frame rates, are defined by the camera.

---

## Digital I/O

The digital I/O functions on the NI 8254R are accessible through 2 TTL inputs, 10 TTL outputs, 13 isolated inputs, and 4 isolated outputs.

You can use input signals as triggers, product selection ports, change detectors, or to read quadrature encoders. Uses for output signals include controlling camera reset and exposure, controlling strobe lighting, outputting inspection results, or communicating with PLCs. You can also define the functions of digital input and output signals.

For information about how to use LabVIEW to implement specific digital I/O functions, refer to the examples at `<LabVIEW>\examples\IMAQ\IMAQ_IO.llb`. For information about how to use C or Visual Basic to implement specific digital I/O functions, refer to the examples at `<National Instruments>\NI-IMAQ_IO\Examples\.`

---

## RIO and LabVIEW FPGA

Behind the digital I/O of the NI 8254R is an FPGA which has been preconfigured with the functionality required for most common machine vision tasks. If the factory configured functionality does not fulfill your requirements, the FPGA is user configurable with the LabVIEW FPGA Module. RIO technology, found throughout the NI platform, includes NI PCI and PXI R Series DAQ devices, NI CVS-1450 Series Compact Vision Systems, the NI 8254R, the NI 8255R, and NI CompactRIO. RIO allows you to develop custom FPGA logic on compact vision systems or with the NI 8254R device to add triggering, pulse-width modulation signals, or custom communications protocols to your machine vision application.

Using National Instruments RIO hardware and the LabVIEW FPGA Module, you can define your hardware without in-depth knowledge of hardware design tools or hardware description languages (HDL). When the signal requirements change, the LabVIEW code can be modified and downloaded to the FPGA to change the I/O mix or type. This flexibility allows you to reuse the same hardware and software at no extra expense.

NI-IMAQ I/O devices such as the NI 8254R, the NI 8255R, and the CVS-1450 Series Compact Vision Systems have 29 digital I/O lines with built-in functionality for communicating with external devices, such as reading quadrature encoder inputs, generating strobe pulses, and writing to or reading from digital lines.

NI-IMAQ I/O devices have 15 digital input lines—13 isolated 24 V lines and two dedicated TTL lines. There are 14 digital output lines—four isolated 24 V lines and 10 dedicated TTL lines. Using these signals, you can dynamically control your lighting or cameras, synchronize with a conveyor belt, or communicate with relays that control solenoids and other actuators.

## TTL Inputs and Outputs

TTL is a fast-switching 5 V digital signaling standard commonly used for applications that require high precision, such as camera triggering. TTL inputs and outputs do not require a separate power supply.



**Caution** Do not connect voltage or current sources to TTL outputs. Doing so could damage the NI 8254R device.

Table 2-1 summarizes the TTL inputs and outputs available on the NI 8254R.

Table 2-1. NI 8254R TTL Inputs and Outputs

Primary Function	Input or Output	Number Available	Signal Names	44-Pin D-SUB on NI 8255R Device Pin Number	37-Pin Terminal Block Number
Trigger	Input	2	TTL Input 0, General Purpose*	1	1
			TTL Input 1, General Purpose*	16	2
Timed Pulse	Output	6	TTL Output 1, Pulse 1	4	5
			TTL Output 2, Pulse 2	6	7
			TTL Output 3, Pulse 3	7	8
			TTL Output 4, Pulse	18	20
			TRIG 1, Pulse 5	24	—
			TRIG 2, Pulse 6	9	—

Table 2-1. NI 8254R TTL Inputs and Outputs (Continued)

Primary Function	Input or Output	Number Available	Signal Names	44-Pin D-SUB on NI 8255R Device Pin Number	37-Pin Terminal Block Number
Watchdog	Output	1	TTL Output 0	3	4
General Purpose	Output	3	TTL Output 5	19	21
			TTL Output 6	21	23
			TTL Output 7	22	24
* TTL Input 0 and TTL Input 1 can also function as trigger change detectors.					

## Isolated Inputs and Outputs

The isolated inputs and outputs on the NI 8254R have a separate ground reference from the main NI 8254R device supply, providing an easy means to prevent ground loops that can introduce noise into a system. You can apply signals up to 30 V to the isolated inputs. The voltage swing of the isolated outputs is determined by the voltage you supply on the 2-position isolated outputs power connector.



**Note**  $V_{iso}$  is referred to as V, and  $C_{iso}$  is referred to as C on the 2-position isolated outputs power connector on the NI 8254R.



**Note** The isolated outputs have current-limiting protection circuitry. If this circuitry is tripped, you can re-enable the outputs by removing the fault and restarting your computer.

Table 2-2 summarizes the isolated inputs and outputs available on the NI 8254R.

Table 2-2. NI 8254R Isolated Inputs and Outputs

Primary Function	Input or Output	Number Available	Signal Names	44-Pin D-SUB on NI 8255R Device Pin Number	37-Pin Terminal Block Number
Trigger	Input	3	TRIG 0* ISO Input 5 <sup>†</sup> ISO Input 8*	11 35 40	— 15 27
Quadrature Encoder	Input	1	ISO Input 6 ISO Input 7	37 38	25 26
External Shutdown Control	Input	1	ISO Input 11	44	31
Product Selection Port <sup>†</sup>	Input	1	ISO Input 0 ISO Input 1 ISO Input 2 ISO Input 3 ISO Input 4	15 30 31 32 34	9 10 11 13 14
General Purpose	Input	2	ISO Input 9* ISO Input 10*	41 43	29 30
General Purpose	Output	4	ISO Output 0 ISO Output 1 ISO Output 2 ISO Output 3	12 13 27 28	198 35 36 37

\* TRIG 0, ISO Input 8, ISO Input 9, and ISO Input 10 can also function as trigger change detectors.  
<sup>†</sup> ISO Input 5 can also function as a latch for the product selection port.

## I/O for Normal Operation

The following sections describe I/O functions that are available on the NI 8254R during normal operation.

## Trigger Inputs

Trigger inputs are available from both TTL inputs and isolated inputs. You can use these trigger inputs to synchronize the NI 8254R with an external event, such as the assertion of a signal generated by a proximity sensor or a PLC, to indicate that an inspection item is passing in front of the camera. The NI 8254R uses this input to initiate a timed pulse that can be used for camera control, lighting control, encoder pulse counting, and result output timing.

For more information about creating a timed pulse output, refer to the *Timed Pulse Output* section.

TTL Input 0, TTL Input 1, TRIG 0, ISO Input 6, ISO Input 7, ISO Input 8, and ISO Input 11 can alternatively function as general-purpose inputs. ISO Input 5 can alternatively function as a latch for the product selection port.

## Timed Pulse Output

The NI 8254R is capable of timed pulse output on six different digital outputs, which provides precise control over time-critical signals, such as camera exposure. This section describes the various uses for the timed pulse output and the parameters you can set to control these outputs.

Uses for timed pulse output include controlling camera reset and exposure, controlling strobe lighting, operating plungers on an assembly line, and communicating with PLCs. You can configure the start of the pulse output generation to occur from software or from a rising or falling edge of a trigger input.

In addition to controlling the timing of pulse output, you can also configure the polarity of the output signal, resulting in a high-true or low-true signal. Based on the polarity setting, the output signal asserts after the appropriate delay time and de-asserts after the configured pulse width. You can set the delay time in microseconds or in quadrature encoder counts from the start signal—either a hardware trigger or a software command. Width is always configured in microseconds.

## Initiating a Timed Pulse

Each timed pulse generator has a trigger input that specifies whether to wait on a particular trigger input to generate the pulse or to immediately generate the pulse when software sets the pulse mode to **Start** in LabVIEW or **imaqIOPulseStart** in C and Visual Basic.

When the pulse generator is configured for a particular trigger input, after generating a pulse, it waits for another trigger before generating another pulse. When the pulse generator is configured to immediately generate the pulse on a software start, after generating a pulse, it immediately generates another pulse.

If the trigger input is set to **Immediate** in LabVIEW or using a **None** status signal in C and Visual Basic, the pulse generation occurs as soon as the pulse mode is set to **Start** in LabVIEW or **imaqIOPulseStart** in C and Visual Basic. If the trigger input is set to one of the hardware trigger inputs, the timed pulse output waits for an assertion edge on the appropriate trigger input. The assertion edge is configurable based on the trigger polarity parameter. It then generates one pulse and rearms to wait for the next trigger. In either case, the pulse output generation stops and resets if the pulse mode parameter is set to **Stop** in LabVIEW or **imaqIOPulseStop** in C and Visual Basic.

The following figure shows an output pulse when a trigger is selected.

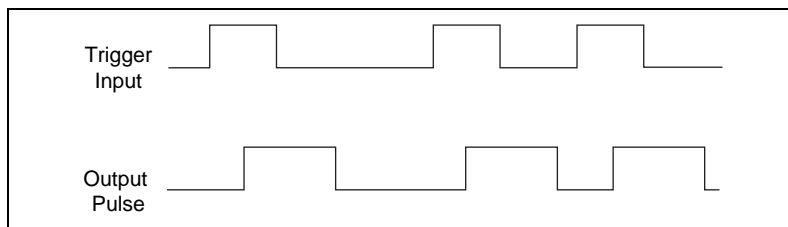

## Pulse Modes

Each pulse generator has a Start, Single Shot, and Stop mode. Configure the pulse generator when in Stop mode. Then, set the pulse generator to Start mode for continuous or rearmed pulses, and set it to Single Shot for a pulse that should assert only once.

## Pulse Delay

Pulse delay is the amount of time between a trigger and the first (assertion) edge of an output pulse. The pulse delay is configurable in units of microseconds or quadrature encoder counts. If configured for microseconds, available values are between 1  $\mu\text{s}$  and 4,294,967,295  $\mu\text{s}$ , which is 4,294 seconds, or approximately 71 minutes. If the delay is configured for quadrature encoder counts, the range of choices is 0 counts to 4,294,967,295 counts.

## Pulse Width

Pulse width is the amount of time between the first (assertion) edge of a pulse and the second (deassertion) edge. Pulse width is configurable only in microseconds from 1  $\mu\text{s}$  to 4,294,967,295  $\mu\text{s}$ .

## Trigger Polarity

Each pulse generator can be individually configured for rising or falling edge triggering. Even if multiple pulse generators are using the same trigger, each can have different polarities.

The following figure shows the output of a pulse generator configured to look for a rising edge trigger and output a high pulse with a microsecond width and delay.

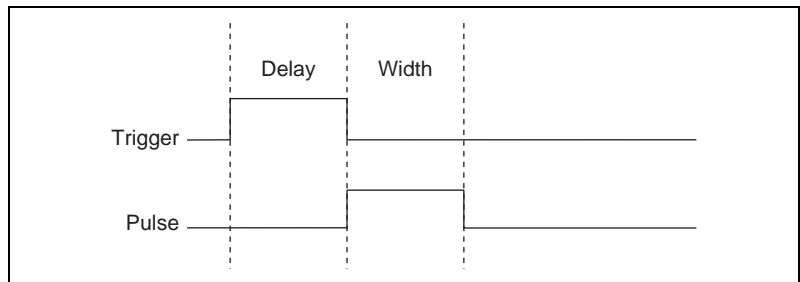

The following figure shows how to create a high and low pulse train with a microsecond delay and width.

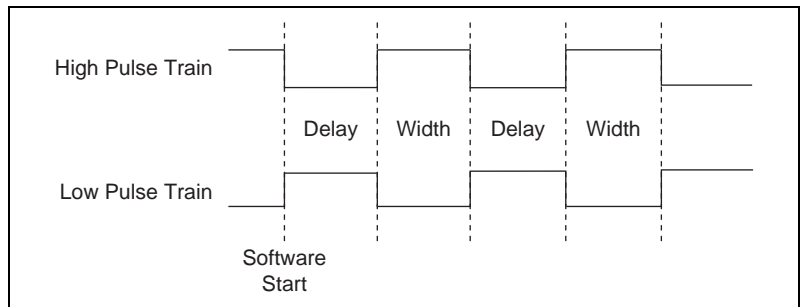

## Trigger Change Detectors

The NI 8254R is capable of detecting edges on various trigger lines and latching this information for future retrieval. This feature is useful for high-precision hardware-monitoring of the presence of external events without the need for software polling. You can arm for the detection of a rising edge, falling edge, or both on a supported trigger input line.

Supported trigger input lines include TTL Input 0, TTL Input 1, ISO Input 8, ISO Input 9, ISO Input 10, and TRIG 0.

## Quadrature Encoder

The quadrature encoder uses ISO Input 6 for its Phase A input and ISO Input 7 for its Phase B input. Encoder speed is limited by the speed of the isolated inputs. Each isolated input can change at a maximum rate of 100 kHz, making the maximum encoder rate 400,000 counts/s.

The quadrature encoder can also be used as a timebase for the pulse generation delay.

The following figure shows a rising edge trigger and a low pulse with a quadrature encoder delay and a microsecond width.

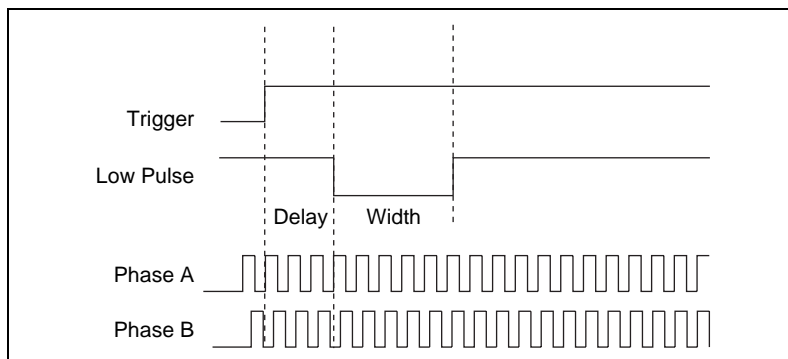

## Product Selection Port

The product selection port consists of a group of five isolated digital inputs that the software running on the NI 8254R reads simultaneously. You can program the NI 8254R to switch between up to 32 ( $2^5$ ) inspection sequences for different parts on an assembly line.

Based on the input to the product selection port, you can configure the application software to run the appropriate inspection sequence. For

example, an upstream NI 8254R device programmed for part classification might drive the product selection port of a downstream NI 8254R device. Alternatively, a PLC with information about which part is being inspected can drive the product selection port of the NI 8254R.

## Using ISO Input 5 as a Latch

You can configure the product selection port to use ISO Input 5 as a latch. A rising edge on ISO Input 5 can latch the data into a data register on the NI 8254R. Before each inspection, the software checks the status of the product select inputs and reads the most recent value latched into the register. If ISO Input 5 is not used as a latch, it can be used as an extra bit of data.



**Note** In Vision Builder AI, ISO Input 5 is always designated as a latch.

Table 2-3 lists the product selection ports.

**Table 2-3.** NI 8254R Product Selection Ports

Function	External Connection
Data(5), rising edge latch	ISO Input 5
Data(4)	ISO Input 4
Data(3)	ISO Input 3
Data(2)	ISO Input 2
Data(1)	ISO Input 1
Data(0)	ISO Input 0

## General-Purpose I/O

General-purpose inputs and outputs are available as both TTL and isolated connections. The software running on the NI 8254R can read the inputs and drive the outputs high or low at any time.

### General-Purpose Inputs

The primary difference between general-purpose inputs and trigger inputs is that you cannot use general-purpose inputs to initiate a timed pulse generator. In an application, use the general-purpose inputs to get the status of the inputs at a given point and not to synchronize the NI 8254R with an external event.

An example of how to use general-purpose inputs is reading the status of a general-purpose input as the first step in your inspection sequence and recording that value as part of your inspection.

## General-Purpose Outputs

The primary difference between general-purpose outputs and timed pulse outputs is that the timing of general-purpose outputs is controlled by software rather than hardware. As a result, timing of general-purpose outputs changes as the inspection algorithm changes, which makes general-purpose outputs less appropriate than timed outputs for camera control, strobe light control, and other applications that require precise timing.

An example of using general-purpose outputs is driving a relay that turns on an **Inspection in Progress** light for an operator to see while the inspection sequence is running.

## I/O for Fault Conditions

The NI 8254R recognizes the following fault conditions:

- External shutdown, when Shutdown mode is enabled
- Watchdog timer expiration

In the event of a fault condition, the behavior of the NI 8254R is dependent on configuration settings of the software-enabled Shutdown mode. To resume operation, address the fault condition and cycle power on your computer.

Table 2-4 summarizes how user configuration affects the behavior of the NI 8254R in the event of a fault condition.

Table 2-4. Fault Condition Behavior

Fault Condition	Shutdown Enabled	Outputs Change to User-Defined States
External Shutdown	On	Yes
	Off	No
Watchdog	On	Yes
	Off	No

The following sections describe each fault condition.

## Shutdown

Shutdown mode is a software-enabled feature that, when activated, allows an external device to halt the NI 8254R device processing operations. Additionally, Shutdown mode allows you to specify user-defined shutdown states for all fault conditions.

When Shutdown mode is enabled and the shutdown input signal, ISO Input 11, turns off, the NI 8254R registers an external shutdown condition. When a fault occurs, outputs operate according to user-defined shutdown states. Each TTL output is configurable to drive high, drive low, or tri-state, and each isolated output is on/off configurable.



**Note** For prototyping when equipment is unavailable, you can wire from V to ISO Input 11 to simulate external equipment that indicates to the NI 8254R to operate normally.

## Watchdog Timer

The watchdog timer is a software configurable feature that can monitor software on the NI 8254R and take action if the software is unresponsive. The millisecond counter on the watchdog timer is configurable up to 65,534 ms, in 1 ms increments, before it expires.

Configure the watchdog timer to take one of the following actions when it expires.



**Caution** Use the Indicator Only option *only* to test the watchdog timer. If software becomes unresponsive, it cannot be relied upon to send notification to the host.

- **Indicator Only**—This option sends the expiration signal back to the development machine through software. **True** indicates an expired watchdog timer. **False** indicates an unexpired watchdog timer. The expiration signal that indicates an expired watchdog timer continues to assert until the watchdog timer is disarmed. Disarming the watchdog timer resets the software indicator.
- **TTL Output 0**—This option outputs a signal on TTL Output 0. **High** indicates that the watchdog timer has expired. **Low** indicates that the watchdog timer has not expired. If the watchdog timer has expired, the expiration signal continues to assert until the watchdog timer is disarmed.
- **Shutdown**—If Shutdown mode is enabled, the outputs go to the user-defined shutdown states.

## Considerations When Connecting the Digital I/O

The isolated trigger inputs on the NI 8254R are current sinking and optically isolated. The following are considerations you need to make when connecting the digital I/O.

### Wiring an Isolated Input to a Sourcing Output Device

You can wire an isolated input to a sourcing output device, as shown in the following figure. Refer to the *NI PCI-8254R Quick Start Guide* for switching thresholds and current requirements.



**Caution** Do not apply a voltage greater than 30 VDC to the isolated inputs. Doing so could damage the NI 8254R.

The following figure shows an example of connecting an isolated input to a sourcing output device.

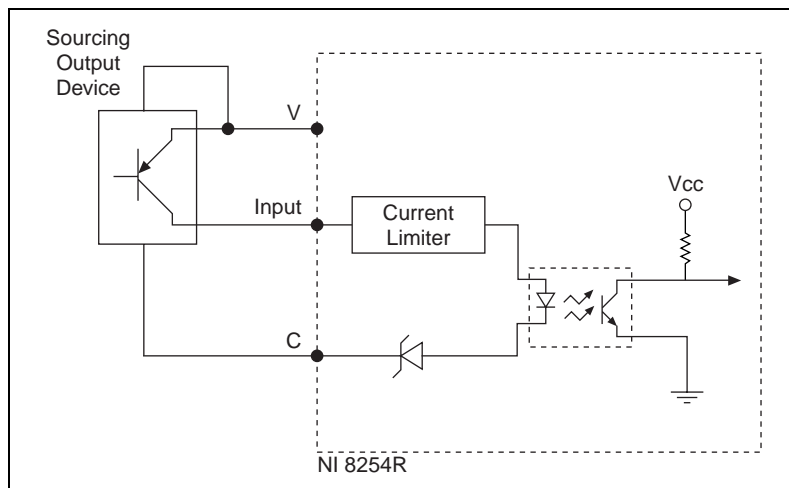

## Wiring an Isolated Output to an External Load

The digital output circuit sources current to external loads, as shown in the following figure.



**Caution** Do *not* draw more than 100 mA from 24 V or 30 V isolated outputs. Do *not* draw more than 50 mA from 5 V isolated outputs.

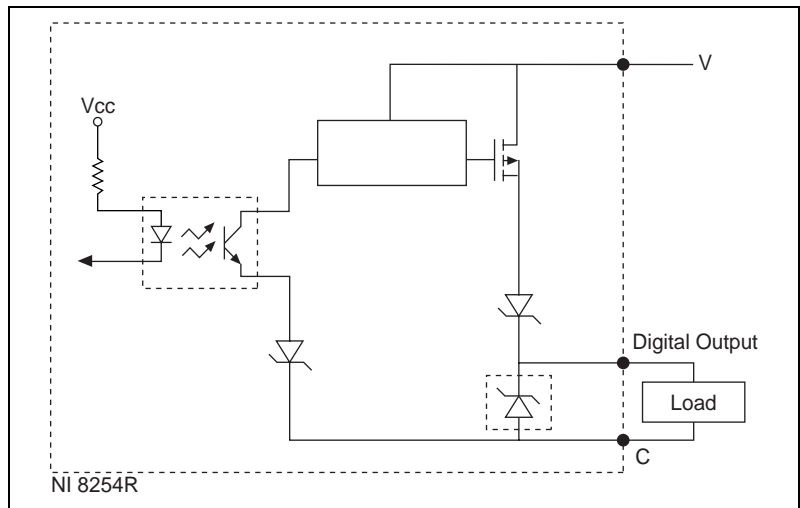

## Protecting Inductive Loads

When an inductive load, such as a relay or solenoid, is connected to an output, a large counter-electromotive force may occur at switching time due to energy stored in the inductive load. This flyback voltage can damage the outputs and the power supply.

To limit flyback voltages at the inductive load, install a flyback diode across the load. Mount the flyback diode as close to the load as possible. Use this protection method if you connect any of the isolated outputs on the NI 8254R to an inductive load.

The following figure shows an example of using an external flyback diode to protect inductive loads.

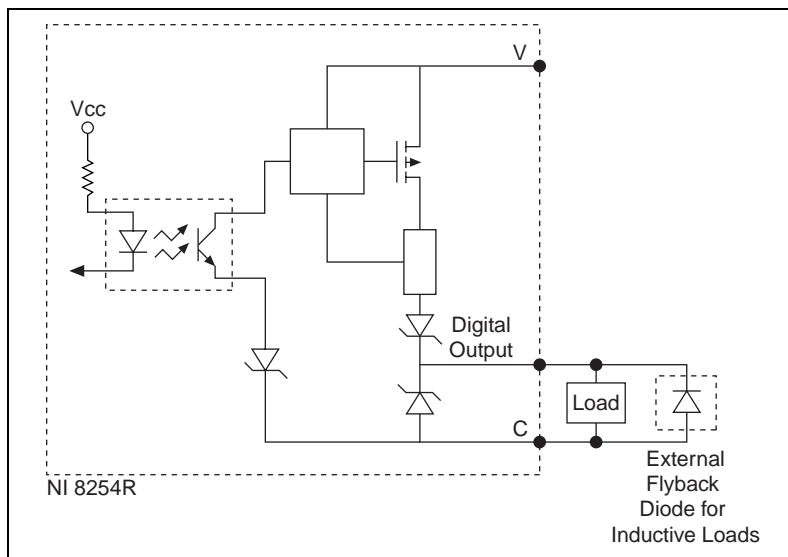

## Transmission Line Effects

Transmission line effects can degrade the signals on the I/O cables and cause instability. To minimize transmission line effects, use twisted pair wires with a characteristic impedance of  $118\ \Omega$  to connect external signals to the 44-pin I/O D-SUB connector.

The following figure shows connections to the 44-pin D-SUB connector that minimize transmission line effects.

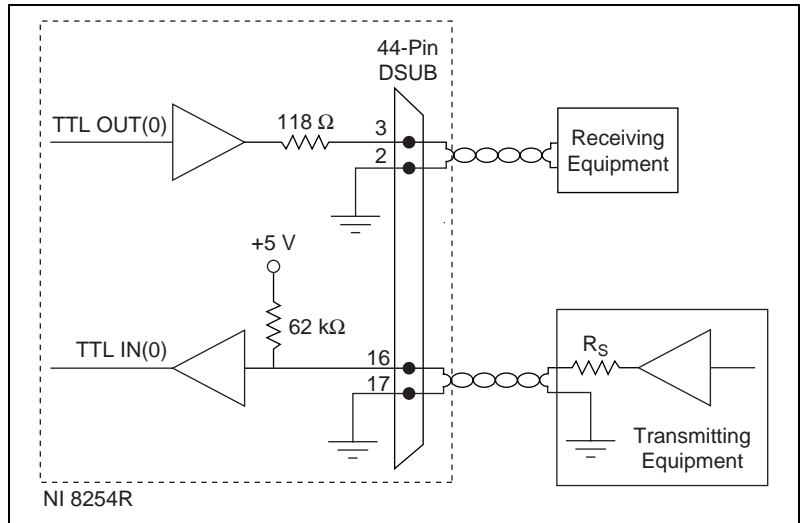

When connecting to TTL inputs on the NI 8254R, match the output impedance of the transmitting device to the characteristic impedance of the cable. For example, if the cable characteristic impedance is  $118\ \Omega$ , make  $R_s$  equal to  $118\ \Omega$ , as shown in the figure above.

# Signal Connections

The following diagram shows the connectors on the NI 8254R device.

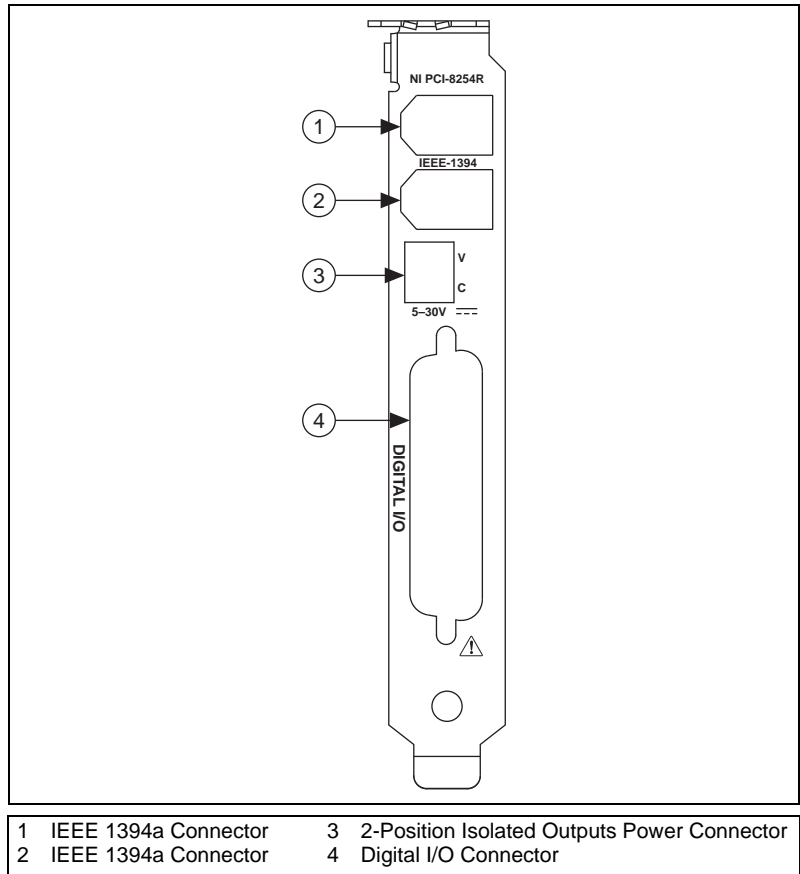

Table 3-1 summarizes the functions of the connectors on the NI 8254R device.

**Table 3-1.** NI 8254R Connector Functions

Peripheral	Connector	Function
Isolated Output Power	2-position isolated outputs power connector	Power for isolated outputs
IEEE 1394	6-pin IEEE 1394a connector	Power and data connection to IEEE 1394 cameras
Digital Input/Output	44-pin female high-density D-SUB	External TTL I/O; External isolated I/O
Camera Power	4-pin computer power	Power from PC power supply to IEEE 1394a connector

## Connectors

This section describes the connectors on the NI 8254R device and includes pinouts and signal descriptions for each connector.

### 2-Position Isolated Outputs Power Connector

The isolated outputs power connector on the NI 8254R device accommodates one power supply. The V terminal provides the isolated output circuitry (5 to 30 VDC) for the NI 8254R device. The C terminal provides the common-mode signal for the NI 8254R device.

Figure 3-1 illustrates the isolated outputs power connector on the NI 8254R device.

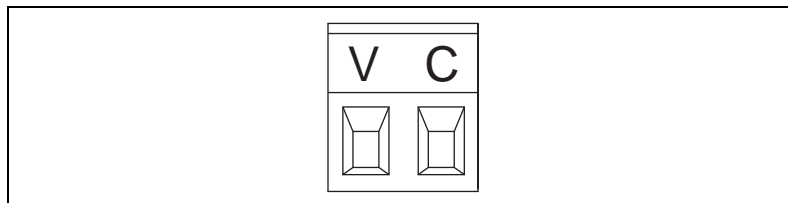

**Figure 3-1.** NI 8254R Isolated Power Connector

Table 3-2 summarizes the functions of the power connector terminals.

**Table 3-2.** Power Connector Terminals

Terminal	Description
V	Isolated power (5 to 30 VDC)
C	Isolated common-mode signal

## IEEE 1394a Connector

The IEEE 1394a connectors on the NI 8254R device provide a reliable, high-frequency connection between the NI 8254R device and up to two DCAM-compliant IEEE 1394 cameras. To access the IEEE 1394a connectors on the NI 8254R device, use any standard 6-pin IEEE 1394 cable.



**Note** You can use a 4-pin to 6-pin converter cable with cameras that have their own external power supply and do not require power from the IEEE 1394 bus.

## General-Purpose Digital I/O

The 44-pin D-SUB connector provides access to the general-purpose digital inputs and outputs. The general-purpose digital I/O available on this connector includes 2 TTL inputs, 9 TTL outputs, 13 isolated inputs, and 4 isolated outputs. For easy connection to the digital I/O connector, use the National Instruments digital I/O cable and the NI Vision I/O Terminal Block and Prototyping Accessory.



**Note** The accessories available for use with the NI 8254R do *not* provide access to all available I/O on the NI 8254R device. To access this I/O, you can create a custom cable using a standard male 44-pin D-SUB connector.

For more information about the National Instruments digital I/O cable and terminal block, refer to the *Optional Equipment* section of the *NI PCI-8254R Quick Start Guide*.



**Note** Isolated inputs are compatible with 5 V logic if the external circuit meets the voltage and current requirements listed in the *Specifications* section of the *NI PCI-8254R Quick Start Guide*.

Figure 3-2 illustrates the 44-pin D-SUB connector on the NI 8254R.

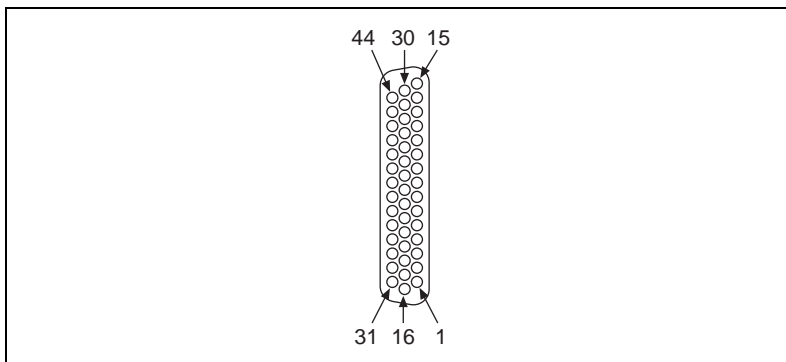

Figure 3-2. NI 8254R 44-Pin D-SUB Connector

Table 3-3 lists pin numbers, signal names, and signal descriptions for the 44-pin D-SUB connector on the NI 8254R and the 37-pin terminal block.



**Caution** Do *not* draw more than 500 mA combined from the V pins on the 44-pin D-SUB connector. Do *not* draw more than 100 mA from 24 V or 30 V isolated outputs. Do *not* draw more than 50 mA from 5 V isolated outputs.

Table 3-3. Signal Connections

44-Pin D-SUB on NI 8255R Device Pin Number	37-Pin Terminal Block Number	Signal Name	Primary Function	Alternate Function
1	1	TTL Input 0	Pulse generator trigger input	Trigger Change Detector, General-purpose input
2	3	C	Common-mode signal of the NI 8255R device main power	—
3	4	TTL Output 0	Watchdog timer output	General-purpose output
4	5	TTL Output 1	Pulse generator output	General-purpose output

Table 3-3. Signal Connections (Continued)

44-Pin D-SUB on NI 8255R Device Pin Number	37-Pin Terminal Block Number	Signal Name	Primary Function	Alternate Function
5	6	C	Common-mode signal of the NI 8255R device main power	—
6	7	TTL Output 2	Pulse generator output	General-purpose output
7	8	TTL Output 3	Pulse generator output	General-purpose output
8	6	C	Common-mode signal of the NI 8255R device main power	—
9	NC	TRIG 2*/TTL Output 9	Pulse generator output	General-purpose output
10	17	V <sub>iso</sub>	Isolated power	—
11	NC	TRIG 0*/ISO Input 12	Pulse generator trigger input	Trigger Change Detector, General-purpose input
12	19	ISO Output 0	General-purpose output	—
13	35	ISO Output 1	General-purpose output	—
14	34	C <sub>iso</sub>	Isolated common-mode signal	—
15	9	ISO Input 0	Input port, Data(0)	—

Table 3-3. Signal Connections (Continued)

<b>44-Pin D-SUB on NI 8255R Device Pin Number</b>	<b>37-Pin Terminal Block Number</b>	<b>Signal Name</b>	<b>Primary Function</b>	<b>Alternate Function</b>
16	2	TTL Input 1	Pulse generator trigger input	Trigger Change Detector, General-purpose input
17	3	C	Common-mode signal of the NI 8255R device main power	—
18	20	TTL Output 4	Pulse generator output	General-purpose output
19	21	TTL Output 5	General-purpose output	—
20	22	C	Common-mode signal of the NI 8255R device main power	—
21	23	TTL Output 6	General-purpose output	—
22	24	TTL Output 7	General-purpose output	—
23	22	C	Common-mode signal of the NI 8255R device main power	—
24	NC	Trig 1*/TTL Output 9	Pulse generator output	General-purpose output
25	33	V <sub>iso</sub>	Isolated power	—
26	34	C <sub>iso</sub>	Isolated common-mode signal	—

Table 3-3. Signal Connections (Continued)

<b>44-Pin D-SUB on NI 8255R Device Pin Number</b>	<b>37-Pin Terminal Block Number</b>	<b>Signal Name</b>	<b>Primary Function</b>	<b>Alternate Function</b>
27	36	ISO Output 2	General-purpose output	—
28	37	ISO Output 3	General-purpose output	—
29	12	C <sub>iso</sub>	Isolated common-mode signal	—
30	10	ISO Input 1	Input port, Data(1)	—
31	11	ISO Input 2	Input port, Data(2)	—
32	13	ISO Input 3	Input port, Data(3)	—
33	16	C <sub>iso</sub>	Isolated common-mode signal	—
34	14	ISO Input 4	Input port, Data(4)	—
35	15	ISO Input 5	Input port latch, Data(5)	Pulse generator trigger input
36	28	C <sub>iso</sub>	Isolated common-mode signal	—
37	25	ISO Input 6	Quadrature encoder Phase A	General-purpose input
38	26	ISO Input 7	Quadrature encoder Phase B	General-purpose input
39	28	C <sub>iso</sub>	Isolated common-mode signal	—

Table 3-3. Signal Connections (Continued)

44-Pin D-SUB on NI 8255R Device Pin Number	37-Pin Terminal Block Number	Signal Name	Primary Function	Alternate Function
40	27	ISO Input 8	Pulse generator trigger input	Trigger Change Detector, General-purpose input
41	29	ISO Input 9	General-purpose input	Trigger Change Detector, General-purpose input
42	32	C <sub>iso</sub>	Isolated common-mode signal	—
43	30	ISO Input 10	General-purpose input	Trigger Change Detector, General-purpose input
44	31	ISO Input 11	User shutdown	General-purpose input

\* TRIG 0, TRIG 1, and TRIG 2 are not available on the 37-pin terminal block or the signal accessory. If you need access to these signals, you can get them directly from the 44-pin D-SUB connector.

## Cabling

### IEEE 1394 Camera Cables

You can connect cameras to the NI 8254R using standard IEEE 1394 cables. IEEE 1394 cables provide both a data path and power to your camera.

## I/O Terminal Block

National Instruments provides an I/O terminal block with the NI 8254R, which can be mounted either horizontally or vertically. The I/O terminal block breaks the signals out into easy-to-use screw terminals and comes with a cable that connects directly to the 44-pin D-SUB connector on the NI 8254R.



**Note** TRIG 0, TRIG 1, and TRIG 2 signals are not accessible via the standard 44 to 37-pin cable and I/O terminal block.

## NI Vision I/O Terminal Block and Prototyping Accessory

Use the NI Vision I/O Terminal Block and Prototyping Accessory to troubleshoot and prototype digital I/O applications for the NI 8254R, the NI 8255R, and the CVS-1450 Series Compact Vision System. The NI Vision I/O Terminal Block and Prototyping Accessory provides screw terminals for easy connections and LEDs for each signal.



**Note** TRIG 0, TRIG 1, and TRIG 2 signals are not accessible via the standard 44 to 37-pin cable and NI Vision I/O Terminal Block and Prototyping Accessory.

## Power Requirements

---

This section describes the power requirements of the NI 8254R.

### Isolated Outputs Power Connector

Figure 3-3 illustrates the isolated outputs power connector on the NI 8254R.

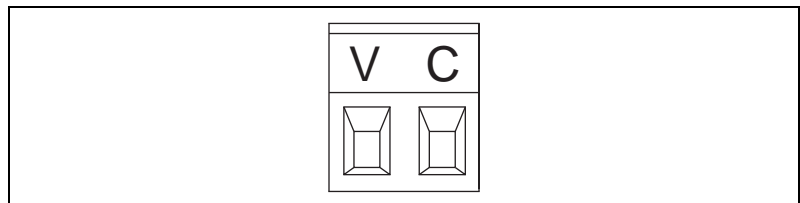
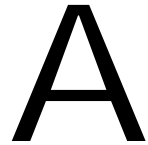

Figure 3-3. NI 8254R Isolated Power Connector

The isolated outputs power connector on the NI 8254R device accommodates one power supply. The V terminal provides the isolated output circuitry (5 to 30 VDC) for the NI 8254R device. The C terminal provides the common-mode signal for the NI 8254R device.

**Table 3-4.** Power Connector Terminals

<b>Terminal</b>	<b>Description</b>
V	Isolated power (5 to 30 VDC)
C	Isolated common-mode signal



---

# Technical Support and Professional Services

Visit the following sections of the National Instruments Web site at [ni.com](http://ni.com) for technical support and professional services:

- **Support**—Online technical support resources at [ni.com/support](http://ni.com/support) include the following:
  - **Self-Help Resources**—For answers and solutions, visit the award-winning National Instruments Web site for software drivers and updates, a searchable KnowledgeBase, product manuals, step-by-step troubleshooting wizards, thousands of example programs, tutorials, application notes, instrument drivers, and so on.
  - **Free Technical Support**—All registered users receive free Basic Service, which includes access to hundreds of Application Engineers worldwide in the NI Discussion Forums at [ni.com/forums](http://ni.com/forums). National Instruments Application Engineers make sure every question receives an answer.

For information about other technical support options in your area, visit [ni.com/services](http://ni.com/services) or contact your local office at [ni.com/contact](http://ni.com/contact).

- **Training and Certification**—Visit [ni.com/training](http://ni.com/training) for self-paced training, eLearning virtual classrooms, interactive CDs, and Certification program information. You also can register for instructor-led, hands-on courses at locations around the world.
- **System Integration**—If you have time constraints, limited in-house technical resources, or other project challenges, National Instruments Alliance Partner members can help. To learn more, call your local NI office or visit [ni.com/alliance](http://ni.com/alliance).
- **Declaration of Conformity (DoC)**—A DoC is our claim of compliance with the Council of the European Communities using the manufacturer's declaration of conformity. This system affords the user protection for electronic compatibility (EMC) and product safety. You can obtain the DoC for your product by visiting [ni.com/certification](http://ni.com/certification).

- **Calibration Certificate**—If your product supports calibration, you can obtain the calibration certificate for your product at [ni.com/calibration](http://ni.com/calibration).

If you searched [ni.com](http://ni.com) and could not find the answers you need, contact your local office or NI corporate headquarters. Phone numbers for our worldwide offices are listed at the front of this manual. You also can visit the Worldwide Offices section of [ni.com/niglobal](http://ni.com/niglobal) to access the branch office Web sites, which provide up-to-date contact information, support phone numbers, email addresses, and current events.

# Glossary

---

## A

ADE Application development environment such as LabVIEW, Visual Basic, or MSVC.

## B

bandwidth The range of frequencies present in a signal, or the range of frequencies to which a measuring device can respond.

## C

current The rate of flow of electric charge measured in amperes

## D

D-SUB A serial connector.

DCAM Digital camera.

deployment machine Machine used to run the software in its final state. this machine typically runs the software without an ADE in the form of an executable.

development machine Machine used to develop an application. A development machine usually has and ADE installed on it.

## E

exposure The amount of time that light reaches the image sensor.

## F

**falling edge** An edge trigger occurs when the trigger signal passes through a specified threshold. A slope that is negative to the trigger is specified as the falling edge.

**FireWire** A high-speed serial interface invented by Apple Computer in 1989, also known as IEEE 1394 or iLink.

**FPGA** Field-programmable gate array. An FPGA is a semi-conductor device which contains a large quantity of gates (logic devices), which are not interconnected, and whose function is determined by a wiring list, which is downloaded to the FPGA. The wiring list determines how the gates are interconnected, and this interconnection is performed dynamically by turning semiconductor switches on or off to enable the different connections.

## H

**HDL** Hardware description language. An example of an HDL is VHDL—a language used to design digital circuitry.

**hot swapping** The act of removing or swapping a device when the computer is still on.

## I

**IEEE** Institute of Electrical and Electronics Engineers. A standard-setting body

**IIDC** IEEE 1394 Trade Association Instrumentation and Industrial Control Working Group, Digital Camera Sub Working Group.

**isolated** A signal which has no electrical connection to the overall system power.

## N

**NI-IMAQ** Driver software for National Instruments image acquisition (IMAQ) hardware.

**P**

pixel	The fundamental picture element in a digital image. The smallest resolvable rectangular area of an image, either on a screen or stored in memory. Each pixel has its own brightness and color, usually represented as red, green, and blue intensities.
PLC	Programmable Logic Controller. An industrial computer used for factory automation, process control, and manufacturing systems.
proximity sensor	Optical sensor which toggles an electrical signal when an object passes near it.

**Q**

quadrature encoder	An encoding technique for a rotating device where two tracks of information are placed on the device, with the signals on the tracks offset by 90 degrees from each other. This makes it possible to detect the direction of the motion.
--------------------	--

**R**

RIO	Reconfigurable inputs and outputs.
rising edge	An edge trigger occurs when the trigger signal passes through a specified threshold. A slope that is positive to the trigger is specified as the rising edge.

**T**

trigger	Any event that causes or starts some form of data capture.
TTL	Transistor-transistor logic. A digital circuit composed of bipolar transistors wired in a certain manner. A typical medium-speed digital technology. Nominal TTL logic levels are 0 and 5 V.
twisted pair cabling	A twisted pair cable has two insulated copper wires that are twisted around each other, to reduce crosstalk or electromagnetic induction between the pairs of wires. Each connection on twisted pair requires both wires.

**V**

VDC

Volts direct current.

voltage

The electromotive force.

# Index

---

## A

acquisition window control, 1-4

## C

cabling, 3-8

calibration certificate (NI resources), A-2

connector functions, 3-2

connectors, 3-2

- 2-position isolated output power, 3-2

- general-purpose digital I/O, 3-3

- IEEE 1394a, 3-3

conventions used in the manual, v

## D

Declaration of Conformity (NI resources), A-1

diagnostic tools (NI resources), A-1

digital I/O

- connection considerations, 2-12

- overview, 2-1

documentation

- conventions used in the manual, v

- NI resources, A-1

drivers (NI resources), A-1

## E

examples (NI resources), A-1

## F

FireWire, 1-3

FPGA, 2-1

## G

general purpose outputs, 2-10

general-purpose I/O, 2-9

general-purpose inputs, 2-9

## H

help, technical support, A-1

## I

I/O for fault conditions, 2-10

I/O for normal operation, 2-4

I/O terminal block, 3-9

IEEE 1394, 1-3

- camera cables, 3-8

- IEEE 1394a, connector, 3-3

- instrument drivers (NI resources), A-1

- isolated inputs, 2-3

  - list of, 2-4

- isolated outputs, 2-3

  - list of, 2-4

  - power connector, 3-9

## K

KnowledgeBase, A-1

## L

LabVIEW FPGA Module, 2-1

LabVIEW, Vision Builder AI, 1-2

latch, 2-9

**N**

- National Instruments support and services, A-1
- NI 1427
  - software programming choices
    - NI Vision Builder for Automated Inspection, 1-2
    - NI Vision Development Module, 1-2
- NI 8254R
  - acquisition window control, 1-4
  - cabling, 3-8
  - connection considerations, 2-12
  - connector functions, 3-2
  - connectors, 3-2
  - digital I/O, 2-1
  - functional overview, 1-3
  - general-purpose I/O, 2-9
  - I/O for fault conditions, 2-10
  - I/O for normal operation, 2-4
  - IEEE 1394, 1-3
  - isolated inputs, 2-3
  - isolated outputs, 2-3
  - LabVIEW FPGA Module, 2-1
  - power requirements, 3-9
  - product selection port, 2-8
  - quadrature encoder, 2-8
  - reconfigurable I/O, 2-1
  - signal connections, 3-1
  - software overview, 1-1
  - start conditions, 1-4
  - timed pulse output, 2-5
  - trigger change detectors, 2-8
  - trigger inputs, 2-5
  - TTL inputs, 2-2
  - TTL outputs, 2-2
- NI 8255R
  - NI Vision Terminal Block and Prototyping Accessory, 3-9

- NI support and services, A-1
- NI Vision Assistant, 1-2
- NI Vision Terminal Block and Prototyping Accessory, 3-9

**P**

- power connector terminals, 3-10
- power requirements, 3-9
- product selection port, 2-8
- programming examples (NI resources), A-1
- protecting inductive loads, 2-13
- pulse delay, 2-6
- pulse modes, 2-6
- pulse width, 2-7

**Q**

- quadrature encoder, 2-8

**R**

- reconfigurable I/O, 2-1
- RIO. *See* reconfigurable I/O

**S**

- shutdown, 2-11
- signal connections, 3-1
- software
  - NI resources, A-1
  - overview, 1-1
  - software programming choices
    - NI Vision Builder for Automated Inspection, 1-2
    - NI Vision Development Module, 1-2
- start conditions, 1-4
- support, technical, A-1

## T

- technical support, A-1
- timed pulse output
  - initiating, 2-5
  - overview, 2-5
- training and certification (NI resources), A-1
- transmission line effects, 2-14
- trigger change detectors, 2-8
- trigger inputs, 2-5
- trigger polarity, 2-7
- troubleshooting (NI resources), A-1
- TTL inputs, 2-2
  - list of, 2-2
- TTL outputs, 2-2
  - list of, 2-2

## W

- watchdog timer, 2-11
- Web resources, A-1
- wiring
  - isolated input to sourcing output device, 2-12
  - isolated output to external load, 2-12