

# NI SPEEDY-33

## User Manual

*Signal Processing Engineering Educational Device for Youth*

## **Worldwide Technical Support and Product Information**

ni.com

### **National Instruments Corporate Headquarters**

11500 North Mopac Expressway Austin, Texas 78759-3504 USA Tel: 512 683 0100

### **Worldwide Offices**

Australia 1800 300 800, Austria 43 0 662 45 79 90 0, Belgium 32 0 2 757 00 20, Brazil 55 11 3262 3599,  
Canada 800 433 3488, China 86 21 6555 7838, Czech Republic 420 224 235 774, Denmark 45 45 76 26 00,  
Finland 385 0 9 725 725 11, France 33 0 1 48 14 24 24, Germany 49 0 89 741 31 30, India 91 80 51190000,  
Israel 972 0 3 6393737, Italy 39 02 413091, Japan 81 3 5472 2970, Korea 82 02 3451 3400,  
Lebanon 961 0 1 33 28 28, Malaysia 1800 887710, Mexico 01 800 010 0793, Netherlands 31 0 348 433 466,  
New Zealand 0800 553 322, Norway 47 0 66 90 76 60, Poland 48 22 3390150, Portugal 351 210 311 210,  
Russia 7 095 783 68 51, Singapore 1800 226 5886, Slovenia 386 3 425 4200, South Africa 27 0 11 805 8197,  
Spain 34 91 640 0085, Sweden 46 0 8 587 895 00, Switzerland 41 56 200 51 51, Taiwan 886 02 2377 2222,  
Thailand 662 278 6777, United Kingdom 44 0 1635 523545

For further support information, refer to the *Technical Support and Professional Services* appendix. To comment on National Instruments documentation, refer to the National Instruments Web site at [ni.com/info](http://ni.com/info) and enter the info code `feedback`.

# Important Information

---

## Warranty

The NI SPEEDY-33 is warranted against defects in materials and workmanship for a period of one year from the date of shipment, as evidenced by receipts or other documentation. National Instruments will, at its option, repair or replace equipment that proves to be defective during the warranty period. This warranty includes parts and labor.

The media on which you receive National Instruments software are warranted not to fail to execute programming instructions, due to defects in materials and workmanship, for a period of 90 days from date of shipment, as evidenced by receipts or other documentation. National Instruments will, at its option, repair or replace software media that do not execute programming instructions if National Instruments receives notice of such defects during the warranty period. National Instruments does not warrant that the operation of the software shall be uninterrupted or error free.

A Return Material Authorization (RMA) number must be obtained from the factory and clearly marked on the outside of the package before any equipment will be accepted for warranty work. National Instruments will pay the shipping costs of returning to the owner parts which are covered by warranty.

National Instruments believes that the information in this document is accurate. The document has been carefully reviewed for technical accuracy. In the event that technical or typographical errors exist, National Instruments reserves the right to make changes to subsequent editions of this document without prior notice to holders of this edition. The reader should consult National Instruments if errors are suspected. In no event shall National Instruments be liable for any damages arising out of or related to this document or the information contained in it.

EXCEPT AS SPECIFIED HEREIN, NATIONAL INSTRUMENTS MAKES NO WARRANTIES, EXPRESS OR IMPLIED, AND SPECIFICALLY DISCLAIMS ANY WARRANTY OF MERCHANTABILITY OR FITNESS FOR A PARTICULAR PURPOSE. CUSTOMER'S RIGHT TO RECOVER DAMAGES CAUSED BY FAULT OR NEGLIGENCE ON THE PART OF NATIONAL INSTRUMENTS SHALL BE LIMITED TO THE AMOUNT THEREFORE PAID BY THE CUSTOMER. NATIONAL INSTRUMENTS WILL NOT BE LIABLE FOR DAMAGES RESULTING FROM LOSS OF DATA, PROFITS, USE OF PRODUCTS, OR INCIDENTAL OR CONSEQUENTIAL DAMAGES, EVEN IF ADVISED OF THE POSSIBILITY THEREOF. This limitation of the liability of National Instruments will apply regardless of the form of action, whether in contract or tort, including negligence. Any action against National Instruments must be brought within one year after the cause of action accrues. National Instruments shall not be liable for any delay in performance due to causes beyond its reasonable control. The warranty provided herein does not cover damages, defects, malfunctions, or service failures caused by owner's failure to follow the National Instruments installation, operation, or maintenance instructions; owner's modification of the product; owner's abuse, misuse, or negligent acts; and power failure or surges, fire, flood, accident, actions of third parties, or other events outside reasonable control.

## Copyright

Under the copyright laws, this publication may not be reproduced or transmitted in any form, electronic or mechanical, including photocopying, recording, storing in an information retrieval system, or translating, in whole or in part, without the prior written consent of National Instruments Corporation.

## Trademarks

National Instruments, NI, ni.com, and LabVIEW are trademarks of National Instruments Corporation. Refer to the *Terms of Use* section on [ni.com/legal](http://ni.com/legal) for more information about National Instruments trademarks.

Other product and company names mentioned herein are trademarks or trade names of their respective companies.

Members of the National Instruments Alliance Partner Program are business entities independent from National Instruments and have no agency, partnership, or joint-venture relationship with National Instruments.

## Patents

For patents covering National Instruments products, refer to the appropriate location: **Help»Patents** in your software, the `patents.txt` file on your CD, or [ni.com/patents](http://ni.com/patents).

## WARNING REGARDING USE OF NATIONAL INSTRUMENTS PRODUCTS

(1) NATIONAL INSTRUMENTS PRODUCTS ARE NOT DESIGNED WITH COMPONENTS AND TESTING FOR A LEVEL OF RELIABILITY SUITABLE FOR USE IN OR IN CONNECTION WITH SURGICAL IMPLANTS OR AS CRITICAL COMPONENTS IN ANY LIFE SUPPORT SYSTEMS WHOSE FAILURE TO PERFORM CAN REASONABLY BE EXPECTED TO CAUSE SIGNIFICANT INJURY TO A HUMAN.

(2) IN ANY APPLICATION, INCLUDING THE ABOVE, RELIABILITY OF OPERATION OF THE SOFTWARE PRODUCTS CAN BE IMPAIRED BY ADVERSE FACTORS, INCLUDING BUT NOT LIMITED TO FLUCTUATIONS IN ELECTRICAL POWER SUPPLY, COMPUTER HARDWARE MALFUNCTIONS, COMPUTER OPERATING SYSTEM SOFTWARE FITNESS, FITNESS OF COMPILERS AND DEVELOPMENT SOFTWARE USED TO DEVELOP AN APPLICATION, INSTALLATION ERRORS, SOFTWARE AND HARDWARE COMPATIBILITY PROBLEMS, MALFUNCTIONS OR FAILURES OF ELECTRONIC MONITORING OR CONTROL DEVICES, TRANSIENT FAILURES OF ELECTRONIC SYSTEMS (HARDWARE AND/OR SOFTWARE), UNANTICIPATED USES OR MISUSES, OR ERRORS ON THE PART OF THE USER OR APPLICATIONS DESIGNER (ADVERSE FACTORS SUCH AS THESE ARE HEREAFTER COLLECTIVELY TERMED "SYSTEM FAILURES"). ANY APPLICATION WHERE A SYSTEM FAILURE WOULD CREATE A RISK OF HARM TO PROPERTY OR PERSONS (INCLUDING THE RISK OF BODILY INJURY AND DEATH) SHOULD NOT BE RELIANT SOLELY UPON ONE FORM OF ELECTRONIC SYSTEM DUE TO THE RISK OF SYSTEM FAILURE. TO AVOID DAMAGE, INJURY, OR DEATH, THE USER OR APPLICATION DESIGNER MUST TAKE REASONABLY PRUDENT STEPS TO PROTECT AGAINST SYSTEM FAILURES, INCLUDING BUT NOT LIMITED TO BACK-UP OR SHUT DOWN MECHANISMS. BECAUSE EACH END-USER SYSTEM IS CUSTOMIZED AND DIFFERS FROM NATIONAL INSTRUMENTS' TESTING PLATFORMS AND BECAUSE A USER OR APPLICATION DESIGNER MAY USE NATIONAL INSTRUMENTS PRODUCTS IN COMBINATION WITH OTHER PRODUCTS IN A MANNER NOT EVALUATED OR CONTEMPLATED BY NATIONAL INSTRUMENTS, THE USER OR APPLICATION DESIGNER IS ULTIMATELY RESPONSIBLE FOR VERIFYING AND VALIDATING THE SUITABILITY OF NATIONAL INSTRUMENTS PRODUCTS WHENEVER NATIONAL INSTRUMENTS PRODUCTS ARE INCORPORATED IN A SYSTEM OR APPLICATION, INCLUDING, WITHOUT LIMITATION, THE APPROPRIATE DESIGN, PROCESS AND SAFETY LEVEL OF SUCH SYSTEM OR APPLICATION.

# Compliance

---

## Compliance with FCC/Canada Radio Frequency Interference Regulations

### Determining FCC Class

The Federal Communications Commission (FCC) has rules to protect wireless communications from interference. The FCC places digital electronics into two classes. These classes are known as Class A (for use in industrial-commercial locations only) or Class B (for use in residential or commercial locations). All National Instruments (NI) products are FCC Class A products.

Depending on where it is operated, this Class A product could be subject to restrictions in the FCC rules. (In Canada, the Department of Communications (DOC), of Industry Canada, regulates wireless interference in much the same way.) Digital electronics emit weak signals during normal operation that can affect radio, television, or other wireless products.

All Class A products display a simple warning statement of one paragraph in length regarding interference and undesired operation. The FCC rules have restrictions regarding the locations where FCC Class A products can be operated.

Consult the FCC Web site at [www.fcc.gov](http://www.fcc.gov) for more information.

### FCC/DOC Warnings

This equipment generates and uses radio frequency energy and, if not installed and used in strict accordance with the instructions in this manual and the CE marking Declaration of Conformity\*, may cause interference to radio and television reception. Classification requirements are the same for the Federal Communications Commission (FCC) and the Canadian Department of Communications (DOC).

Changes or modifications not expressly approved by NI could void the user's authority to operate the equipment under the FCC Rules.

### Class A

#### Federal Communications Commission

This equipment has been tested and found to comply with the limits for a Class A digital device, pursuant to part 15 of the FCC Rules. These limits are designed to provide reasonable protection against harmful interference when the equipment is operated in a commercial environment. This equipment generates, uses, and can radiate radio frequency energy and, if not installed and used in accordance with the instruction manual, may cause harmful interference to radio communications. Operation of this equipment in a residential area is likely to cause harmful interference in which case the user is required to correct the interference at their own expense.

#### Canadian Department of Communications

This Class A digital apparatus meets all requirements of the Canadian Interference-Causing Equipment Regulations.

Cet appareil numérique de la classe A respecte toutes les exigences du Règlement sur le matériel brouilleur du Canada.

### Compliance with EU Directives

Users in the European Union (EU) should refer to the Declaration of Conformity (DoC) for information\* pertaining to the CE marking. Refer to the Declaration of Conformity (DoC) for this product for any additional regulatory compliance information. To obtain the DoC for this product, visit [ni.com/certification](http://ni.com/certification), search by model number or product line, and click the appropriate link in the Certification column.

\* The CE marking Declaration of Conformity contains important supplementary information and instructions for the user or installer.

# Conventions

---

The following conventions are used in this manual:

» The » symbol leads you through nested menu items and dialog box options to a final action. The sequence **File»Page Setup»Options** directs you to pull down the **File** menu, select the **Page Setup** item, and select **Options** from the last dialog box.



This icon denotes a note, which alerts you to important information.



This icon denotes a caution, which advises you of precautions to take to avoid injury, data loss, or a system crash.

**bold** Bold text denotes items that you must select or click in the software, such as menu items and dialog box options. Bold text also denotes parameter names.

*italic* Italic text denotes variables, emphasis, a cross reference, or an introduction to a key concept. Italic text also denotes text that is a placeholder for a word or value that you must supply.

`monospace` Text in this font denotes text or characters that you should enter from the keyboard, sections of code, programming examples, and syntax examples. This font is also used for the proper names of disk drives, paths, directories, programs, subprograms, subroutines, device names, functions, operations, variables, filenames, and extensions.

**Platform** Text in this font denotes a specific platform and indicates that the text following it applies only to that platform.

# Contents

---

## Chapter 1

### NI SPEEDY-33 Overview

Theory of Operation.....	1-2
Safety Information .....	1-2
Installation .....	1-4
Software, Drivers, and Examples .....	1-4
LabVIEW DSP Module.....	1-4
Visual Application Builder (VAB).....	1-5

## Chapter 2

### NI SPEEDY-33 Functional Description and Interface

DSP .....	2-2
Memory Map .....	2-4
Memory.....	2-5
On-Chip Memory .....	2-5
Flash Memory.....	2-5
Ports .....	2-5
PC USB Port.....	2-5
Power Port .....	2-6
Audio Stereo Input Port.....	2-6
Audio Stereo Output Port .....	2-6
Onboard Microphones .....	2-7
Digital Output Port LEDs .....	2-7
Switch Input Port .....	2-7
Stereo A/D, D/A .....	2-8
I/O Connectors .....	2-8
Simple Expansion Digital I/O Connector.....	2-8
Standard Expansion Analog I/O Connectors.....	2-9
Jumpers .....	2-9
Audio Input Level Jumpers .....	2-9
Flash Boot Jumper.....	2-10
Flash Write Enable Jumper .....	2-11
Reset Button.....	2-11

**Appendix A  
Specifications**

**Appendix B  
Technical Support and Professional Services**

**Glossary**

**Index**

# NI SPEEDY-33 Overview

The NI SPEEDY-33 (Signal Processing Engineering Educational Device for Youth featuring the Texas Instruments VC33 DSP) is a self-contained, high-performance, programmable product for signal processing applications. It boasts an easy-to-use, fast Digital Signal Processor (DSP) along with a number of features important to many signal processing applications. The NI SPEEDY-33 onboard flash memory, together with an easy-to-learn, easy-to-use software programming tool, supports the quick creation of standalone DSP-based products.

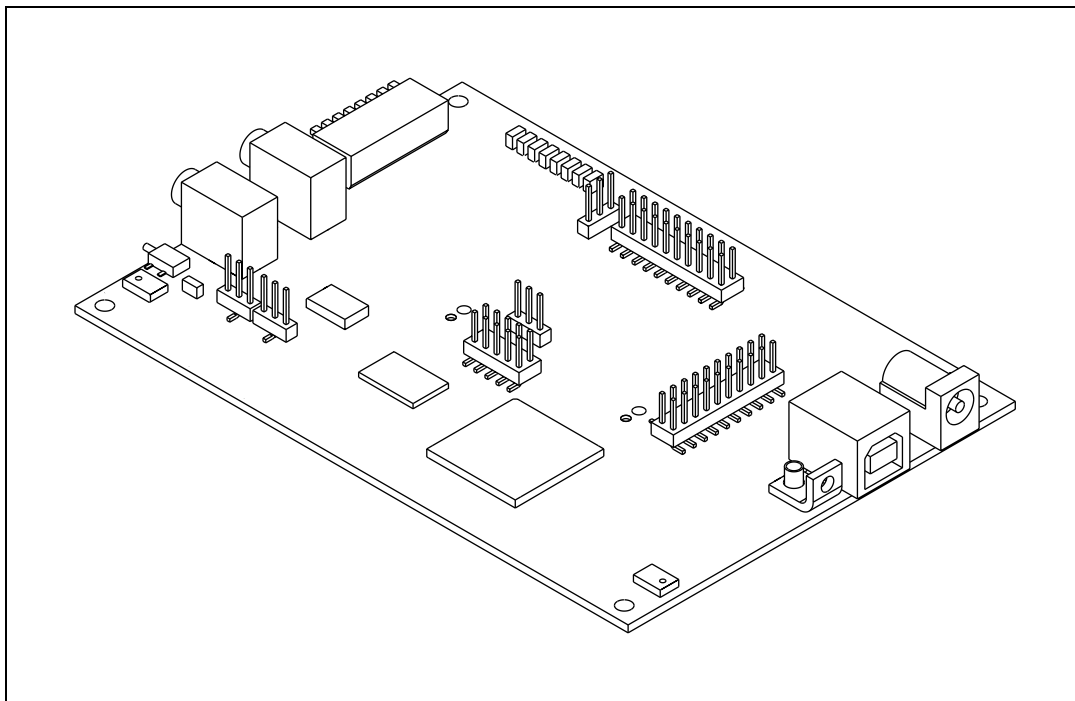

**Figure 1-1.** The NI SPEEDY-33

# Theory of Operation

---

The NI SPEEDY-33 is a low-cost, high-performance floating-point TMS320VC33-based DSP system connected to a standard PC through the USB port. This easy-to-use system supports a variety of DSP processing, including audio applications with two input/output analog channels sampled at 48 kHz, and other applications with onboard digital I/O for controlling motors/servos. The NI SPEEDY-33 features 34 K × 32 words of on-chip memory. The 512 K × 8 onboard flash memory allows for storage of both the program application (programmed with the LabVIEW DSP Module or VAB software), as well as data such as tables, sound waveforms, and so on.

The NI SPEEDY-33 has eight lines of digital I/O, arranged as an eight-bit switch input port, and eight digital output LEDs. The digital I/O lines can be programmed with the LabVIEW DSP Module or VAB software. The eight inputs and eight outputs are also accessible through the simple expansion digital I/O connector. After the flash memory is programmed, the NI SPEEDY-33 can be unplugged from the PC and run in standalone mode.

# Safety Information

---

The following section contains important safety information that you must follow when installing and using the module.

Do not operate the module in a manner not specified in this document. Misuse of the module can result in a hazard. You can compromise the safety protection built into the module if the module is damaged in any way. If the module is damaged, return it to National Instruments (NI) for repair.

Do not substitute parts or modify the module except as described in this document. Use the module only with the chassis, modules, accessories, and cables specified in the installation instructions. You must have all covers and filler panels installed during operation of the module.

Do not operate the module in an explosive atmosphere or where there may be flammable gases or fumes. If you must operate the module in such an environment, it must be in a suitably rated enclosure.

If you need to clean the module, use a soft, nonmetallic brush. Make sure that the module is completely dry and free from contaminants before returning it to service.

Operate the module only at or below Pollution Degree 2. Pollution is foreign matter in a solid, liquid, or gaseous state that can reduce dielectric strength or surface resistivity. The following is a description of pollution degrees:

- Pollution Degree 1 means no pollution or only dry, nonconductive pollution occurs. The pollution has no influence.
- Pollution Degree 2 means that only nonconductive pollution occurs in most cases. Occasionally, however, a temporary conductivity caused by condensation must be expected.
- Pollution Degree 3 means that conductive pollution occurs, or dry, nonconductive pollution occurs that becomes conductive due to condensation.

You must insulate signal connections for the maximum voltage for which the module is rated. Do not exceed the maximum ratings for the module. Do not install wiring while the module is live with electrical signals. Do not remove or add connector blocks when power is connected to the system. Avoid contact between your body and the connector block signal when hot swapping modules. Remove power from signal lines before connecting them to or disconnecting them from the module.

Operate the module at or below the measurement category<sup>1</sup> marked on the hardware label. Measurement circuits are subjected to working voltages<sup>2</sup> and transient stresses (overvoltage) from the circuit to which they are connected during measurement or test. Measurement categories establish standard impulse withstand voltage levels that commonly occur in electrical distribution systems. The following is a description of measurement categories:

- Measurement Category I is for measurements performed on circuits not directly connected to the electrical distribution system referred to as MAINS<sup>3</sup> voltage. This category is for measurements of voltages from specially protected secondary circuits. Such voltage measurements include signal levels, special equipment, limited-energy parts of equipment, circuits powered by regulated low-voltage sources, and electronics.
- Measurement Category II is for measurements performed on circuits directly connected to the electrical distribution system. This category

---

<sup>1</sup> Measurement categories, also referred to as installation categories, are defined in electrical safety standard IEC 61010-1.

<sup>2</sup> Working voltage is the highest rms value of an AC or DC voltage that can occur across any particular insulation.

<sup>3</sup> MAINS is defined as a hazardous live electrical supply system that powers equipment. Suitably rated measuring circuits may be connected to the MAINS for measuring purposes.

refers to local-level electrical distribution, such as that provided by a standard wall outlet (for example, 115 AC voltage for U.S. or 230 AC voltage for Europe). Examples of Measurement Category II are measurements performed on household appliances, portable tools, and similar modules.

- Measurement Category III is for measurements performed in the building installation at the distribution level. This category refers to measurements on hard-wired equipment such as equipment in fixed installations, distribution boards, and circuit breakers. Other examples are wiring, including cables, bus bars, junction boxes, switches, socket outlets in the fixed installation, and stationary motors with permanent connections to fixed installations.
- Measurement Category IV is for measurements performed at the primary electrical supply installation (<1,000 V). Examples include electricity meters and measurements on primary overcurrent protection devices and on ripple control units.

## Installation

---

To install and set up the NI SPEEDY-33, refer to the *NI SPEEDY-33 Installation Guide*. You can find this document on the NI SPEEDY-33 User Documentation CD or the National Instruments Web site at [ni.com/manuals](http://ni.com/manuals).

## Software, Drivers, and Examples

---

The NI SPEEDY-33 is supported by the LabVIEW DSP Module and Visual Application Builder (VAB). A variety of example DSP applications are standard with both software packages.

### LabVIEW DSP Module

Refer to the *LabVIEW DSP Module Release Notes* for information about installing the LabVIEW DSP Module software and NI SPEEDY-33 drivers onto your computer. You can find this document by selecting **Start» All Programs»National Instruments»LabVIEW 7.1 Embedded Edition»LabVIEW Manuals»DSP\_Release\_Notes.pdf**.

For a tutorial on using the LabVIEW DSP Module with the NI SPEEDY-33, refer to the *Getting Started with the LabVIEW DSP Module* document. You can find this document by selecting **Start» All Programs»National Instruments»LabVIEW 7.1 Embedded Edition»LabVIEW Manuals»DSP\_Getting\_Started.pdf**.

Example applications for the NI SPEEDY-33 can be found in the NI Example Finder; in LabVIEW, select **Help»Find Examples**.

All NI user documentation is available on the National Instruments Web site at [ni.com/manuals](http://ni.com/manuals).

## Visual Application Builder (VAB)

**(Infinity Kit Users)** Refer to the *NI SPEEDY-33 Installation Guide* for information about installing the VAB software and the NI SPEEDY-33 drivers onto your computer. You can find this document on the NI SPEEDY-33 User Documentation CD.

For a tutorial on using VAB with the NI SPEEDY-33, refer to the *VAB Starter's Guide*. The document can be found by selecting **Start» All Programs»VAB for INFINITY»VAB User Manual**.

Software examples for the NI SPEEDY-33 can be found by clicking the **Open Examples** button, shown at left, on the VAB tool bar.



All NI user documentation is available on the National Instruments Web site at [ni.com/manuals](http://ni.com/manuals).

## NI SPEEDY-33 Functional Description and Interface

This chapter describes the NI SPEEDY-33 hardware functions and details of interfacing and configuring the device. Figure 2-1 shows the NI SPEEDY-33 layout.

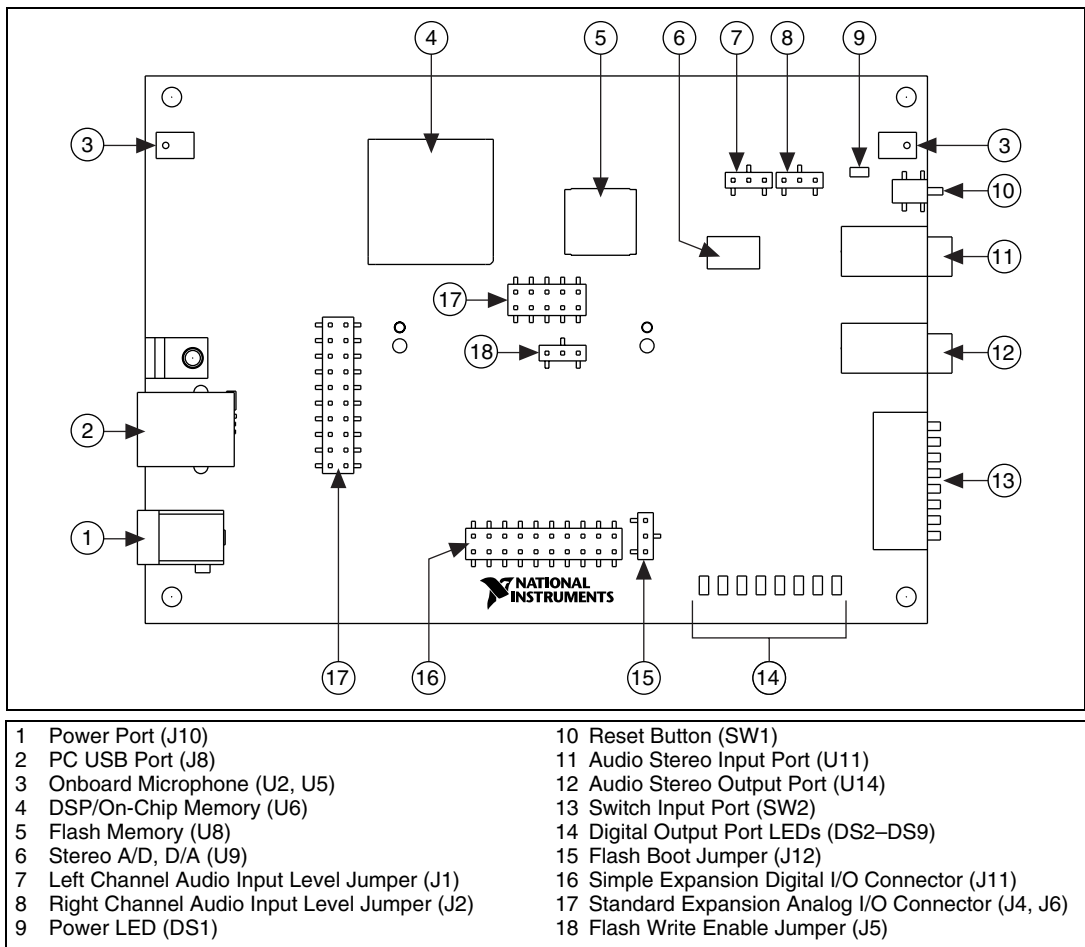

**Figure 2-1.** NI SPEEDY-33 Top View

# DSP

---

The digital signal processor on the NI SPEEDY-33 is a powerful floating-point, flexible, and easy-to-use processor designed by Texas Instruments.

The VC33 DSP is capable of high performance mathematical operations. It is a 32-bit, floating-point processor manufactured in 0.18  $\mu\text{m}$  four-level-metal CMOS (Timeline) technology, and is part of the SM320C3x™ generation of DSPs from Texas Instruments.

The VC33 DSP internal busing and special digital signal processing instruction set have the speed and flexibility to execute up to 150 million floating-point operations per second (MFLOPS). The VC33 DSP optimizes speed by implementing functions in hardware that other processors implement through software or microcode. This hardware-intensive approach provides performance previously unavailable on a single chip.



**Note** Although this DSP is capable of 75 MIPS, 150 MFLOPS, the crystal driving the DSP on the NI SPEEDY-33 is slightly slower than what would be required to achieve this maximum speed, namely 14.7456 MHz as opposed to the maximum 15 MHz. This allows for specific desirable sample rates to be achieved for the A/D and D/A hardware described in the [Stereo A/D, D/A](#) section. Refer to the Appendix A, [Specifications](#), for information about DSP speed.

The VC33 DSP can perform parallel multiply and ALU operations on integer or floating-point data in a single cycle. Each processor possesses a general-purpose register file, a program cache, dedicated ARAUs, internal dual-access memories, one DMA channel supporting concurrent I/O, and a short machine-cycle time, resulting in a high-performance, easy-to-use device.

Typical signal processing applications are enhanced by the large address space, multiprocessor interface, internally- and externally-generated wait states, one external interface port, two timers, one serial port, and a multiple-interrupt structure. The VC33 DSP supports a wide variety of system applications from host processor to dedicated coprocessor. High-level language support is easily implemented through a register-based architecture, large address space, powerful addressing modes, flexible instruction set, and well-supported floating-point arithmetic.

Figure 2-2 shows the architectural details of the VC33 DSP.

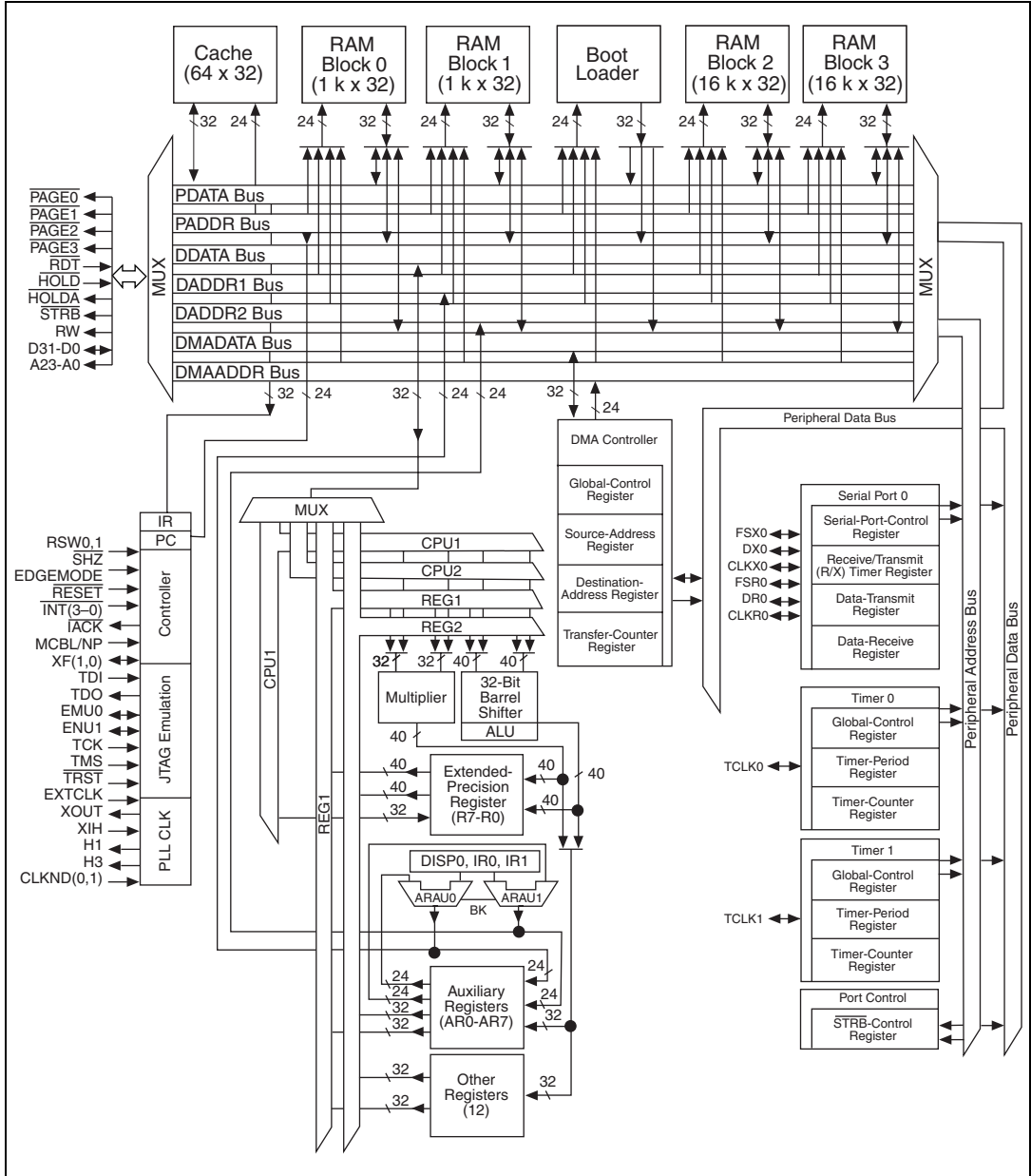

Figure 2-2. DSP Functional Block Diagram

# Memory Map

The DSP runs in microcomputer/bootloader mode on the NI SPEEDY-33. The memory map for the NI SPEEDY-33 is shown in Figure 2-3.

0h	Reserved for Bootloader Operations
FFFh	
1000h	External RAM (1008 KB) 5 Wait States
3FFFFh	
40000h	(Empty)
3FFFFFFh	
400000h	Flash Memory (2048 KB in Space, Byte-Wide, Lowest Byte) 7 Wait States
47FFFFh	
480000h	(Empty)
7FFFFFFh	
800000h	Internal RAM Block 2 (64 KB)
803FFFh	
804000h	Internal RAM Block 3 (64 KB)
807FFFh	
808000h	Peripheral Bus Memory-Mapped Registers (24 KB Internal)
8097FFh	
809800h	Internal RAM Block 0 (4 KB)
809BFFh	
809C00h	Internal RAM Block 1 (4 KB)
809FC0h	
809FC1h	User Program Interrupt and Trap Branch Table
809FFFh	
	(Empty)
80B000h	Board Status/CTL, XXF
80B003h	USB Peripheral Status
80B004h	USB Host EVEN
80B005h	USB Host ODD
80B007h	Switch Read/LED Write
C00000h	CompactFlash Control/Data
C000Fh	
FFF000h	
FFFFFFh	USB Boot Area

**Figure 2-3.** NI SPEEDY-33 Memory Map

# Memory

---

There are two types of available memory on the NI SPEEDY-33, on-chip memory and flash memory.

## On-Chip Memory

The DSP uses on-chip memory for algorithms because of its fast speed. There are 136 KB of on-chip RAM that the DSP can access with zero wait states. This memory is used for both program and data space.

## Flash Memory

Flash memory is included to allow the NI SPEEDY-33 to be programmed and run in standalone mode, without connection to a PC. This is essential for producing actual products or self-standing prototypes. Refer to the [Flash Boot Jumper](#) section for information on configuring the jumper to enable flash memory boot up for standalone mode.

The flash memory is byte-wide and organized as  $512\text{ K} \times 8$ , with the DSP mapping it to a  $512\text{ K} \times 32$  (2048 KB) area, only able to read the lowest byte (upper 24 bits are not read by or written to the DSP). Refer to the [Flash Write Enable Jumper](#) section for information on jumper configurations for enabling or disabling flash memory write protection.

# Ports

---

## PC USB Port

The PC USB port (J8) connects the NI SPEEDY-33 (target) to a PC (host) with a standard USB cable. The NI SPEEDY-33 functions as a full-speed USB device when connected to the PC host. The PC USB port is a Type B USB port (peripheral USB port) and conforms to USB Specification 1.1. When the NI SPEEDY-33 is connected to the PC, the USB port supplies power to the device, eliminating the need for the power port (J10), described in the [Power Port](#) section. When power is supplied to the device, the power LED lights.



**Caution** Do *not* connect the power source to the power port while the NI SPEEDY-33 device is connected to the PC.

## Power Port



**Caution** Do *not* connect the power source to the power port while the NI SPEEDY-33 device is connected to the PC.

The power port (J10) can supply the NI SPEEDY-33 with external power when operating the device in standalone mode, without being connected to the PC through USB. When power is supplied to the device, the power LED lights.

The input voltage must be 9 VDC, at 500 mA, with the outside contact being ground and inner contact being positive VDC. An appropriate 2.5 mm jack can be used in conjunction with a 9 V battery (pack) to optionally supply power for battery-powered applications. Refer to Appendix A, [Specifications](#), for complete power supply specifications.

## Audio Stereo Input Port

Audio input can be connected to the audio stereo input port (U11).



**Caution** Ensure that line level audio signals are *not* connected to the audio input when the NI SPEEDY-33 is configured for microphone level. It is possible to damage the audio input circuitry by overdriving the input.

If an external microphone is used, it should be capable of operating with a standard stereo jack; not all microphones will work in this fashion. Many PC microphones will not work because they require a DC voltage to be driven on one of the inputs. Traditional mono microphones generally work fine.

It is important to ensure that the audio input level jumpers (J1, J2) setting is configured appropriately for microphone level or line level, depending upon the audio source connected to this port. Refer to the [Audio Input Level Jumpers](#) section for more information.



**Note** The onboard microphones are disconnected by mechanical disconnect when an audio source is connected to the audio stereo input port.

## Audio Stereo Output Port

The audio stereo output port (U14) can be connected to a set of stereo amplified speakers. Typical amplified speakers used for PC sound should provide good output. You also can plug external headsets to this port, although there is no hardware control over the output gain, or signal level.

## Onboard Microphones

---

Two onboard microphones (U2 and U5) can be used in applications requiring audio input or involving audio signal phase difference measurements. When the microphones are used, the input gain level of each microphone should be set to the microphone level setting described in the [Audio Input Level Jumpers](#) section.



**Caution** Ensure that line level audio signals are *not* connected to the audio input when the NI SPEEDY-33 is configured for microphone level. It is possible to damage the audio input circuitry by overdriving the input.

The onboard microphones are directly connected to the audio input conditioning circuitry, unless an external microphone is connected at the stereo input port (U11), as described in the [Audio Input Level Jumpers](#) section. If an external microphone is connected, the onboard microphones are disconnected from the input circuitry by mechanical disconnect.

## Digital Output Port LEDs

---

Eight memory-mapped LEDs are located on the NI SPEEDY-33 for general-purpose output. The LEDs are enabled by writing a 1 to the appropriate bit of the LED port. The LED output state is echoed on pins on the simple expansion digital I/O connector (J11), described in the [Simple Expansion Digital I/O Connector](#) section.

## Switch Input Port

---

There are eight memory-mapped general-purpose switch inputs on the NI SPEEDY-33. These switch inputs are accessed by the DSP through reading the appropriate bit of the switch input port. The switch inputs are connected in parallel to pins on the simple expansion digital I/O connector (J11). All switches should be in the OFF (open) position when connecting the expansion digital I/O connector, as described in the [Simple Expansion Digital I/O Connector](#) section.

## Stereo A/D, D/A

---

The 16-bit stereo audio CODEC included on the NI SPEEDY-33 allows for up to 48 kHz dual-channel sampling on the input signal. Software components are included in the LabVIEW DSP Module and VAB to allow 8 kHz, 18 kHz, 24 kHz, 36 kHz, and 48 kHz sample rates to be used in applications.

Refer to the [Audio Input Level Jumpers](#) section for information on jumper settings that configure the amount of gain, from the onboard or external microphones, applied to the input audio signals.

## I/O Connectors

---

### Simple Expansion Digital I/O Connector

The simple 20-pin expansion header (J11) allows for easy interface to external hardware. The header includes power, ground, eight digital inputs, and eight digital outputs under DSP control.

The eight input bits are co-mapped to the switch input port. The eight output bits are co-mapped to the digital output port LEDs, described in the [Digital Output Port LEDs](#) section.

If the input bits on this connector will be used by an external piece of hardware, the switch input port, described in the [Switch Input Port](#) section, must have all the switches set in the OFF (open) position (all switches up, away from device). An ON (closed) switch position (switch down, towards the device) will effectively short that specific input bit to ground. Switch 1 correlates to IN1 on the connector, switch 2 correlates to IN2, and so on. The connector pinout is shown in Figure 2-4.

5 V (Out)	1	2	3 V (Out)
IN1 (In)	3	4	OUT1 (Out)
IN2 (In)	5	6	OUT2 (Out)
IN3 (In)	7	8	OUT3 (Out)
IN4 (In)	9	10	OUT4 (Out)
IN5 (In)	11	12	OUT5 (Out)
IN6 (In)	13	14	OUT6 (Out)
IN7 (In)	15	16	OUT7 (Out)
IN8 (In)	17	18	OUT8 (Out)
GND	19	20	ResetLow (In)

**Figure 2-4.** Simple Expansion Digital I/O Connector (J11)

The digital I/O signals are 3.3 V, but the inputs are 5 V tolerant. Although not required, pin 20 (ResetLow) can be driven low to reset the DSP; it is pulled high by the NI SPEEDY-33.

## Standard Expansion Analog I/O Connectors

A set of two connectors, J4 and J6, make up the standard expansion analog I/O connectors, that can be used for optional daughter modules. The daughter modules can be used for applications requiring different A/D and/or D/A functionality than that provided by the standard 16-bit stereo CODEC normally found on the NI SPEEDY-33.

Refer to the *Connecting Accessories to the NI SPEEDY-33* document for information on NI and third-party daughter modules for use with the NI SPEEDY-33. This document is available on [ni.com/manuals](http://ni.com/manuals).

## Jumpers

### Audio Input Level Jumpers

The audio input level jumpers (J1, J2) control the amount of gain applied to the input audio signals.

The microphone level setting has the highest gain for the onboard microphones (U2, U5), the line level setting has less gain and is appropriate for the line level audio interface (for example, CD players, MP3 players, and so on).

These settings will affect the gain of the external audio source, and should be left in the line level setting if an external microphone or audio source is used at audio stereo input port (U10), described in the [Stereo A/D, D/A](#) section. Table 2-1 shows the possible audio input level settings.



**Caution** Ensure that line level audio signals are *not* connected to the audio input when the NI SPEEDY-33 is configured in the microphone level setting. It is possible to damage the audio input circuitry by overdriving the input.

**Table 2-1.** Audio Input Level Jumpers (J1, J2) Settings

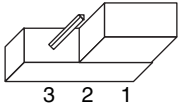
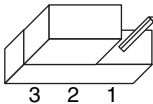
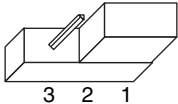
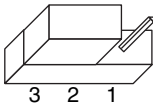
<b>Jumper</b>	<b>Microphone Level</b>	<b>Line Level (Default Setting)</b>
Audio Input Level, Left Channel (J1)	Position 1 	Position 3 
Audio Input Level, Right Channel (J2)	Position 1 	Position 3 

## Flash Boot Jumper

The flash boot jumper (J12) controls whether the DSP will attempt to boot from the flash memory. The default setting is for the DSP to boot from flash memory, described in the [Flash Memory](#) section. You must set the NI SPEEDY-33 to the enable flash boot setting to run the device in standalone mode.

If the NI SPEEDY-33 will only be used with the USB connection to PC, the flash boot can be disabled, though it is not recommended. Table 2-2 shows the possible flash boot settings.

**Table 2-2.** Flash Boot Jumper (J12) Settings

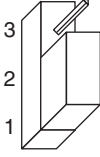
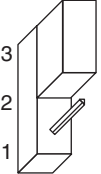
Jumper	Enable Flash Boot (Default Setting)	Disable Flash Boot
Flash Boot	Position 1 	Position 3 

## Flash Write Enable Jumper

The flash write enable jumper (J5) controls whether the DSP can write to the flash memory, described in the [Flash Memory](#) section. This configuration setting is useful for write protecting the DSP algorithm for production purposes. When the flash write is disabled, the DSP is unable to modify the contents, even if it attempts to do so. Table 2-3 shows the possible flash write enable settings.

**Table 2-3.** Flash Write Enable Jumper (J5) Settings

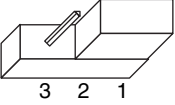
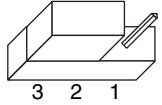
Jumper	Enable Flash Write (Default Setting)	Disable Flash Write
Flash Write Enable	Position 1 	Position 3 

## Reset Button

The reset button (SW1) is a small push button on the NI SPEEDY-33 that manually resets the DSP. The DSP will need to be reset in the event of a software or hardware freeze.



---

# Specifications

Specifications listed below are typical at 25 °C unless otherwise noted.

## Analog I/O

Input ..... Stereo 48 kHz 16 bit A/D

Output..... Stereo 48 kHz 16 bit D/A

Supported sampling rates ..... 8 kHz, 18 kHz, 24 kHz, 36 kHz,  
48 kHz

Maximum working voltage for analog inputs  
(signal + common mode) ..... 600 mV

Maximum working voltage for analog outputs  
(signal + common mode) ..... 1.41 V

Input impedance

    Left to AI GND..... 30 k $\Omega$

    Right to AI GND..... 30 k $\Omega$

## Digital I/O

Input ..... 8 bit switch,  
pins <IN1..IN8> on J11

Output..... 8 bit LEDs,  
pins <OUT1..OUT8> on J11

Maximum working voltage ..... TTL 5 V signal

## Memory

On-chip RAM ..... 34 K  $\times$  32

Flash ..... 512 K  $\times$  8

## DSP

DSP.....TMS320VC33

- High-performance floating-point digital signal processor (DSP)
  - 150 million floating-point operations per second (MFLOPS)
  - 75 million instructions per second (MIPS)
- 34 K × 32 bit (1.1-Mbit) on-chip words of dual-access static random-access memory (SRAM) configured in 2 × 6 K plus 2 × 1 K blocks to improve internal performance
- 32-bit high-performance CPU
- 16/32-bit integer and 32/40-bit floating-point operations
- Boot-program loader
- 32-Bit instruction word, 24-Bit Addresses
- Fabricated using the 0.18-μm (leff-effective gate length) TImeline™ technology by Texas Instruments (TI)
- On-chip memory-mapped peripherals
- Direct Memory Access (DMA)
- Coprocessor for concurrent I/O and CPU operation
- Parallel arithmetic/logic unit (ALU) and multiplier execution in a single cycle
- Supports standalone operation

## Bus Interface

USB .....Full speed 1.1

## Power Requirements

Input voltage

External power supply

powered operation .....9 VDC at 500 mA at power port with appropriate safety and EMC Certification marks, which are acceptable in the country in which the product is to be installed

USB powered operation .....USB bus power

Device maximum current .....0.233 A

## Physical

Dimensions.....	8.89 cm × 12.7 cm × 1.91 cm (3.5 in. × 5 in. × .75 in.).
Weight.....	2.1 g (61 oz)
USB connector .....	Type B USB port, conforms to USB Specification 1.1
Connector .....	Standard mini stereo jack
I/O connectors	
J1, J2, J5, J12 .....	0.10 in. × 0.10 in. × 0.23 in. in 1 × 3 rows
J4.....	0.10 in. × 0.10 in. × 0.23 in. in 2 × 5 rows
J6, J11 .....	0.10 in. × 0.10 in. × 0.23 in. in 2 × 10 rows

## Environmental

Operating temperature.....	0 to 55 °C
Storage temperature .....	–20 to 70 °C
Humidity .....	10 to 90% RH, noncondensing
Maximum altitude .....	2,000 m
Pollution Degree (indoor use only).....	2

## Safety

This product is designed to meet the requirements of the following standards of safety for electrical equipment for measurement, control, and laboratory use:

- IEC 61010-1, EN 61010-1
- UL 61010-1
- CAN/CSA-C22.2 No. 61010-1



**Note** For UL and other safety certifications, refer to the product label, or visit [ni.com/certification](http://ni.com/certification), search by model number or product line, and click the appropriate link in the Certification column.

## Electromagnetic Compatibility

Emissions .....EN 55011 Class A at 10 m;  
FCC Part 15A above 1 GHz

Immunity .....EN 61326:1997 + A2:2001,  
Table 1

CE, C-Tick, and FCC Part 15 (Class A) Compliant



**Note** For EMC compliance, operate this device with shielded cabling.

## CE Compliance

This product meets the essential requirements of applicable European Directives, as amended for CE Marking, as follows:

Low-Voltage Directive (safety).....73/23/EEC

Electromagnetic Compatibility  
Directive (EMC) .....89/336/EEC



**Note** Refer to the Declaration of Conformity (DoC) for this product for any additional regulatory compliance information. To obtain the DoC for this product, visit [ni.com/certification](http://ni.com/certification), search by model number or product line, and click the appropriate link in the Certification column.

---

# Technical Support and Professional Services

Visit the following sections of the National Instruments Web site at [ni.com](http://ni.com) for technical support and professional services:

- **Support**—Online technical support resources at [ni.com/support](http://ni.com/support) include the following:
  - **Self-Help Resources**—For answers and solutions, visit the award-winning National Instruments Web site for software drivers and updates, a searchable KnowledgeBase, product manuals, step-by-step troubleshooting wizards, thousands of example programs, tutorials, application notes, instrument drivers, and so on.
  - **Free Technical Support**—All registered users receive free Basic Service, which includes access to hundreds of Application Engineers worldwide in the NI Developer Exchange at [ni.com/exchange](http://ni.com/exchange). National Instruments Application Engineers make sure every question receives an answer.

For information about other technical support options in your area, visit [ni.com/services](http://ni.com/services) or contact your local office at [ni.com/contact](http://ni.com/contact).

- **Training and Certification**—Visit [ni.com/training](http://ni.com/training) for self-paced training, eLearning virtual classrooms, interactive CDs, and Certification program information. You also can register for instructor-led, hands-on courses at locations around the world.
- **System Integration**—If you have time constraints, limited in-house technical resources, or other project challenges, National Instruments Alliance Partner members can help. To learn more, call your local NI office or visit [ni.com/alliance](http://ni.com/alliance).
- **Declaration of Conformity (DoC)**—A DoC is our claim of compliance with the Council of the European Communities using the manufacturer's declaration of conformity. This system affords the user protection for electronic compatibility (EMC) and product safety. You can obtain the DoC for your product by visiting [ni.com/certification](http://ni.com/certification).

If you searched [ni.com](http://ni.com) and could not find the answers you need, contact your local office or NI corporate headquarters. Phone numbers for our worldwide offices are listed at the front of this manual. You also can visit the Worldwide Offices section of [ni.com/niglobal](http://ni.com/niglobal) to access the branch office Web sites, which provide up-to-date contact information, support phone numbers, email addresses, and current events.

# Glossary

---

Symbol	Prefix	Value
p	pico	$10^{-12}$
n	nano	$10^{-9}$
$\mu$	micro	$10^{-6}$
m	milli	$10^{-3}$
k	kilo	$10^3$
M	mega	$10^6$
G	giga	$10^9$
T	tera	$10^{12}$

## Numbers/Symbols

%	percent
+	positive of, or plus
-	negative of, or minus
±	plus or minus
<	less than
>	greater than
≤	less than or equal to
≥	greater than or equal to
/	per
°	degree
Ω	ohm
+5 V (signal)	+5 VDC source signal

## A

A	amperes
A/D	Analog-to-Digital
AC	Alternating Current
ADC	Analog-to-Digital Converter—An electronic device, often an integrated circuit, that converts an analog voltage to a digital number.
ADC resolution	the resolution of the ADC measured in bits. A 16-bit ADC has a higher resolution, and thus a higher degree of accuracy, than a 12-bit ADC.
ADE	Application development environment such as LabVIEW, LabWindows™/CVI™, BridgeVIEW, Visual Basic, C, and C++.
AI	Analog Input
analog	A signal whose amplitude can have a continuous range of values.
AO	Analog Output

## B

b	bit—one binary digit, either 0 or 1
B	byte—Eight related bits of data, an eight-bit binary number. Also used to denote the amount of memory required to store one byte of data.
bandwidth	The range of frequencies present in a signal, or the range of frequencies to which a measuring device can respond.
bit	One binary digit, either 0 or 1.
boot	The way you start or restart your computer or device. The procedure that is run immediately following hardware reset or power-up.
buffer	Temporary storage for acquired or generated data (software).
bus	The group of conductors that interconnect individual circuitry in a computer. Typically, a bus is the expansion interface to which I/O or other devices are connected. Examples of PC buses are the ISA bus and PCI bus.

BW bandwidth

byte eight related bits

## C

C Celsius

CE European emissions control standard

CFR Code of Federal Regulations

CH channel

channel Pin or wire lead to which you apply or from which you read the analog or digital signal. Analog signals can be single-ended or differential. For digital signals, you group channels to form ports. Ports usually consist of either four or eight digital channels.

CMRR Common-Mode Rejection Ratio—A measure of the ability of a differential amplifier to reject interference from a common-mode signal, usually expressed in decibels (dB).

CMV Common-Mode Voltage

CODEC coder-decoder—An electronic device that converts analog signals, such as video and voice signals, into digital form, and then compresses them to conserve bandwidth on a transmission path. The NI SPEEDY-33 CODEC also converts digital signals into analog form.

connector A fixture (either male or female) attached to a cable or chassis for quickly making and breaking one or more circuits.

**D**

D/A	Digital-to-Analog
DAQ	<p>data acquisition—(1) Collecting and measuring electrical signals from sensors, transducers, and test probes or fixtures and processing the measurement data using a computer.</p> <p>(2) Collecting and measuring the same kinds of electrical signals with A/D and/or DIO boards plugged into a computer, and possibly generating control signals with D/A and/or DIO boards in the same computer.</p>
DAQ device	A data acquisition device. Examples are DIO, E Series MIO, and Lab/1200 plug-in data acquisition devices.
dB	decibel—The unit for expressing a logarithmic measure of the ratio of two signal levels: $\text{dB} = 20\log_{10} V1/V2$ , for signals in volts.
DC	Direct Current
DC coupled	Allowing the transmission of both AC and DC signals.
default setting	A default parameter value recorded in the driver. In many cases, the default input of a control is a certain value (often 0) that means <i>use the current default setting</i> .
device	A plug-in data acquisition product, card, or pad that can contain multiple channels and conversion devices. Plug-in products, PCMCIA cards, and devices such as the DAQPad-1200, which connects to your computer parallel port, are all examples of DAQ devices. SCXI modules are distinct from devices, with the exception of the SCXI-1200, which is a hybrid.
digital	An electronic technology where a signal only has two states: off and on, most often called zero and one. In contrast, analog refers to a signal that can have a continuous range of values.
digital I/O	<p>The capability of an instrument to generate and acquire digital signals.</p> <p>Static digital I/O refers to signals where the values are set and held, or rarely change. Dynamic digital I/O refers to digital systems where the signals are continuously changing, often at multi-MHz clock rates. The NI SPEEDY-33 is a static digital I/O device.</p>
digital port	See <a href="#">port</a> .

DIO	Digital Input/Output
DMA	Direct Memory Access—A method by which data is transferred to/from computer memory from/to a device or memory on the bus while the processor does something else. DMA is the fastest method of transferring data to/from computer memory.
DR	Data Receive
drivers/driver software	Software that controls a specific hardware device such as a DAQ device.
DSP	(1) Digital Signal Processing (2) Digital Signal Processor—a specialized microprocessor designed specifically for digital signal processing, generally in real-time. Digital signal processors can also be used to perform general-purpose computation, though they are not optimized for this function.
dual-access memory	Memory that can be sequentially accessed by more than one controller or processor but not simultaneously accessed. Also known as shared memory.
<b>E</b>	
EEPROM	Electrically Erasable Programmable Read-Only Memory—ROM that can be erased with an electrical signal and reprogrammed.
EMC	electromagnetic compliance
EMI	electromagnetic interference
event	The condition or state of an analog or digital signal.
expansion connector	A connector on the device for connecting additional signals to the DSP.
<b>F</b>	
F	(1) Fahrenheit—A temperature measurement scale. (2) farad—A measurement unit of capacitance.
FIFO	First-In First-Out memory buffer—The first data stored is the first data sent to the acceptor. FIFOs are often used on DAQ devices to temporarily store incoming or outgoing data until that data can be retrieved or output.

flash A form of rewritable memory chip that, unlike a Random Access Memory chip, holds content without maintaining a power supply.

frequency The number of alternating signals that occur per unit time.

ft feet

## H

h hour

Hz hertz—Cycles per second of a periodic signal; the unit of measure for frequency.

## I

I/O Input/Output—The transfer of data to/from a computer system involving communications channels, operator interface devices, and/or data acquisition and control interfaces.

in. inch or inches

instrument driver A set of high-level software functions that controls a specific GPIB, VXI, or RS232 programmable instrument or a specific plug-in DAQ device. Instrument drivers are available in several forms, ranging from a function callable language to a virtual instrument (VI) in LabVIEW. You can download instrument drivers from the Instrument Driver Network at [ni.com/idnet](http://ni.com/idnet).

## J

jack See [port](#).

jumper A small rectangular device used to connect two adjacent posts on a circuit board. Jumpers are used on some SCXI modules and terminal blocks to either select certain parameters or enable/disable circuit functionality.

**K**

k kilo—The standard metric prefix for 1,000, or  $10^3$ , used with units of measure such as volts, hertz, and meters.

K (1) kelvin  
(2) kilo—The prefix for 1,024, or  $2^{10}$ , used with B in quantifying data or computer memory.

kbytes/s A unit for data transfer that means 1,000 or  $10^3$  bytes/s.

kS 1,000 samples

**L**

LabVIEW A graphical programming language.

LabVIEW DSP Module A fully-featured graphical DSP design tool based on LabVIEW.

LED Light-Emitting Diode

library A file containing compiled object modules, each comprised of one of more functions, that can be linked to other object modules that make use of these functions.

**M**

m meters

M (1) Mega, the standard metric prefix for 1 million or  $10^6$ , when used with units of measure such as volts and hertz.  
(2) mega, the prefix for 1,048,576, or  $2^{20}$ , when used with B to quantify data or computer memory.

max maximum

MB megabytes of memory

Mbytes/s A unit for data transfer that means 1 million or  $10^6$  bytes/s.

memory	(1) The high-speed electronic storage components of a computer or instrument product. Typically, access times of electronic memories are less than 100 ns, while hard disk drives have access times in the range of 10 ms. The most common form of electronic memory is Random Access Memory (RAM). (2) The chips in a computer that can store data when the computer is powered on. Different from storage devices, such as disks or tapes.
memory map	Maps physical resources such as RAM and EPROM to particular CPU addresses. A software memory map maps particular code segments to particular CPU addresses.
memory buffer	See <i>buffer</i> .
MFLOPS	Million floating-point operations per second.
min	(1) minutes (2) minimum
<b>N</b>	
NC	Normally Closed, or Not Connected
NP	No Pullup
<b>O</b>	
onboard channels	Channels provided by the plug-in data acquisition device.
OUT	output signal
<b>P</b>	
p	pull up (v.), pull-up (adj.)
PC	Personal Computer
peripherals	Devices that can be connected to your computer or the NI SPEEDY-33. Common peripheral devices are USB DAQ cards, printers, and keyboards.

port (1) A communications connection on a computer or a remote controller.  
(2) A digital port, consisting of four or eight lines of digital input and/or output.

## R

ROM Read-Only Memory

## S

s seconds

S Samples

S/s Samples per second—Used to express the rate at which a DAQ device samples an analog signal.

sample An instantaneous measurement of a signal, normally using an analog-to-digital convertor in a DAQ device.

SPEEDY-33 Signal Processing Engineering Educational Device for Youth— A self-contained, high-performance, programmable product for signal processing applications.

switch (n.) A device for routing signals between two points.

## U

USB Universal Serial Bus—A 480 Mbit/s serial bus with up to 12 Mbps bandwidth for connecting computers to keyboards, printers, and other peripheral devices. USB 2.0 retains compatibility with the original USB specification.

## V

V volts

VAB Visual Application Builder—A component-based DSP design software.

VI Virtual Instrument—(1) A combination of hardware and/or software elements, typically used with a PC, that has the functionality of a classic stand-alone instrument.  
(2) A LabVIEW software module (VI), which consists of a front panel user interface and a block diagram program.

Visual Application Builder See *VAB*.

volatile memory Memory that loses its contents when the power is turned off.

## W

word The standard number of bits that a processor or memory manipulates at one time. Microprocessors typically use 8-, 16-, or 32-bit words.

# Index

---

## A

- analog, standard expansion
  - I/O connectors, 2-9
- audio input level jumpers, 2-9
  - left channel (table), 2-10
  - microphone level (caution), 2-10
  - right channel (table), 2-10
  - settings (table), 2-10
- audio stereo input port, 2-6
  - and onboard microphones (note), 2-6
  - using microphone level (caution), 2-6
- audio stereo output port, 2-6

## B

- block diagram, DSP, 2-3

## C

- CODEC, 2-8
- connector
  - I/O, 2-8
  - simple expansion digital I/O, 2-8
  - simple expansion digital I/O pinout (figure), 2-9
  - standard expansion analog I/O, 2-9
  - USB, 2-5

## D

- Declaration of Conformity (NI resources), B-1
- diagnostic tools (NI resources), B-1
- diagram, 2-1
- digital
  - output port LEDs, 2-7
  - simple expansion I/O connector, 2-8

- simple expansion I/O connector pinout (figure), 2-9
- switch input port, 2-7

- digital signal processor. *See* DSP
- disabling flash boot (table), 2-11
- documentation, NI resources, B-1
- drivers
  - LabVIEW DSP Module, 1-4
  - NI resources, B-1
  - Visual Application Builder, 1-5
- drivers (NI resources), B-1
- DS1 (power LED), 2-5
- DS2–DS9 (digital output port LEDs), 2-7
- DSP, 2-2
  - block diagram, 2-3
  - on-chip memory, 2-5
  - resetting, 2-11

## E

- enabling flash boot (table), 2-11
- examples (NI resources), B-1
- expansion I/O connector
  - analog, 2-9
  - digital, 2-8
- external
  - headsets, using, 2-6
  - microphones, using, 2-6

## F

- flash boot jumper, 2-10
  - settings (table), 2-11
- flash memory, 2-5
  - disabling flash write, 2-11
  - enabling flash write, 2-11
  - enabling flash write setting (table), 2-11

- flash boot jumper, 2-10
- flash write enable jumper, 2-11
- write protection, 2-11
- flash write enable jumper, 2-11
  - settings (table), 2-11
- functional description, 2-1

## H

- hardware installation, 1-4
- help, technical support, B-1

## I

- I/O connector
  - simple expansion digital, 2-8
  - standard expansion analog, 2-9
- installation, 1-4
  - safety information, 1-2
- instrument drivers (NI resources), B-1
- interface, 2-1

## J

- J1 (left channel audio input level jumper), 2-9
- J2 (right channel audio input level jumper), 2-9
- J4 (standard expansion analog I/O connector), 2-9
- J5 (flash write enable jumper), 2-11
- J6 (standard expansion analog I/O connector), 2-9
- J8 (PC USB port), 2-5
- J10 (power port), 2-6
- J11 (simple expansion digital I/O connector), 2-8
- J12 (flash boot jumper), 2-10
- jumper
  - audio input level, 2-9
  - flash boot, 2-10
  - flash write enable, 2-11

## K

- KnowledgeBase, B-1

## L

- LabVIEW DSP Module, 1-4
- LED
  - digital output port, 2-7
  - power, 2-5

## M

- memory
  - flash, 2-5
  - on-chip, 2-5
- memory map
  - (figure), 2-4
- microphone
  - external, 2-6
  - onboard, 2-7
- mode, standalone, 1-2

## N

- National Instruments support and services, B-1
- NI SPEEDY-33
  - diagram, 2-1
  - digital output port LEDs, 2-7
  - drivers, 1-4
  - DSP, 2-2
  - functional description, 2-1
  - I/O connectors, 2-8
  - installation, 1-4
  - interface, 2-1
  - jumpers, 2-9
  - memory, 2-5
  - memory map, 2-4
  - onboard microphones, 2-7
  - overview, 1-1
  - ports, 2-5

- reset button, 2-11
- software, 1-4
- software examples, 1-4
- stereo A/D, D/A, 2-8
- switch input port, 2-7
- theory of operation, 1-2

NI support and services, B-1

## O

- onboard microphone, 2-7
  - configuring microphone level (caution), 2-7
- on-chip memory, 2-5
- overview, 1-1

## P

- PC USB port, 2-5
  - connecting with power source (caution), 2-5
- pinout, simple expansion digital I/O connector (figure), 2-9
- port
  - audio stereo input, 2-6
  - audio stereo output, 2-6
  - digital output LEDs, 2-7
  - PC USB, 2-5
  - power, 2-6
  - switch input, 2-7
- power
  - LED, 2-5
  - port, 2-6
- programming examples (NI resources), B-1

## R

- reset button, 2-11
- resetting the DSP, 2-11

## S

- safety information, 1-2
- simple expansion digital I/O connector, 2-8
  - pinout (figure), 2-9
- software
  - examples, 1-4
  - LabVIEW DSP Module, 1-4
  - NI resources, B-1
  - Visual Application Builder, 1-5
- speakers, using, 2-6
- standalone mode, 1-2, 2-6
- standard expansion analog I/O connectors, 2-9
- stereo
  - A/D, D/A, 2-8
  - amplified speakers, using, 2-6
  - input port, 2-6
  - output port, 2-6
- support, technical, B-1
- SW1 (reset button), 2-11
- SW2 (switch input port), 2-7
- switch input port, 2-7

## T

- technical support, B-1
- theory of operation, 1-2
- training and certification (NI resources), B-1
- troubleshooting (NI resources), B-1

## U

- U2 (onboard microphone), 2-7
- U5 (onboard microphone), 2-7
- U6
  - DSP, 2-2
  - on-chip memory, 2-5
- U8 (flash memory), 2-5
- U9 (stereo A/D, D/A), 2-8
- U11 (audio stereo input port), 2-6
- U14 (audio stereo output port), 2-6

USB port, 2-5  
    connecting with power source  
    (caution), 2-5

## **V**

VAB. *See* Visual Application Builder  
Visual Application Builder, 1-5

## **W**

Web resources, B-1