

PXI

NI PXI-1050 User Manual

Combination Chassis for PXI, CompactPCI, and SCXI™ Modules

Worldwide Technical Support and Product Information

ni.com

National Instruments Corporate Headquarters

11500 North Mopac Expressway Austin, Texas 78759-3504 USA Tel: 512 683 0100

Worldwide Offices

Australia 1800 300 800, Austria 43 0 662 45 79 90 0, Belgium 32 0 2 757 00 20, Brazil 55 11 3262 3599, Canada 800 433 3488, China 86 21 6555 7838, Czech Republic 420 224 235 774, Denmark 45 45 76 26 00, Finland 385 0 9 725 725 11, France 33 0 1 48 14 24 24, Germany 49 0 89 741 31 30, India 91 80 5190000, Israel 972 0 3 6393737, Italy 39 02 413091, Japan 81 3 5472 2970, Korea 82 02 3451 3400, Lebanon 961 0 1 33 28 28, Malaysia 1800 887710, Mexico 01 800 010 0793, Netherlands 31 0 348 433 466, New Zealand 0800 553 322, Norway 47 0 66 90 76 60, Poland 48 22 3390150, Portugal 351 210 311 210, Russia 7 095 783 68 51, Singapore 1800 226 5886, Slovenia 386 3 425 4200, South Africa 27 0 11 805 8197, Spain 34 91 640 0085, Sweden 46 0 8 587 895 00, Switzerland 41 56 200 51 51, Taiwan 02 2377 2222, Thailand 662 992 7519, United Kingdom 44 0 1635 523545

For further support information, refer to the *Technical Support and Professional Services* appendix. To comment on National Instruments documentation, refer to the National Instruments Web site at ni.com/info and enter the info code `feedback`.

Important Information

Warranty

The NI PXI-1050 chassis is warranted against defects in materials and workmanship for a period of one year from the date of shipment, as evidenced by receipts or other documentation. National Instruments will, at its option, repair or replace equipment that proves to be defective during the warranty period. This warranty includes parts and labor.

The media on which you receive National Instruments software are warranted not to fail to execute programming instructions, due to defects in materials and workmanship, for a period of 90 days from date of shipment, as evidenced by receipts or other documentation. National Instruments will, at its option, repair or replace software media that do not execute programming instructions if National Instruments receives notice of such defects during the warranty period. National Instruments does not warrant that the operation of the software shall be uninterrupted or error free.

A Return Material Authorization (RMA) number must be obtained from the factory and clearly marked on the outside of the package before any equipment will be accepted for warranty work. National Instruments will pay the shipping costs of returning to the owner parts which are covered by warranty.

National Instruments believes that the information in this document is accurate. The document has been carefully reviewed for technical accuracy. In the event that technical or typographical errors exist, National Instruments reserves the right to make changes to subsequent editions of this document without prior notice to holders of this edition. The reader should consult National Instruments if errors are suspected. In no event shall National Instruments be liable for any damages arising out of or related to this document or the information contained in it.

EXCEPT AS SPECIFIED HEREIN, NATIONAL INSTRUMENTS MAKES NO WARRANTIES, EXPRESS OR IMPLIED, AND SPECIFICALLY DISCLAIMS ANY WARRANTY OF MERCHANTABILITY OR FITNESS FOR A PARTICULAR PURPOSE. CUSTOMER'S RIGHT TO RECOVER DAMAGES CAUSED BY FAULT OR NEGLIGENCE ON THE PART OF NATIONAL INSTRUMENTS SHALL BE LIMITED TO THE AMOUNT THEREFORE PAID BY THE CUSTOMER. NATIONAL INSTRUMENTS WILL NOT BE LIABLE FOR DAMAGES RESULTING FROM LOSS OF DATA, PROFITS, USE OF PRODUCTS, OR INCIDENTAL OR CONSEQUENTIAL DAMAGES, EVEN IF ADVISED OF THE POSSIBILITY THEREOF. This limitation of the liability of National Instruments will apply regardless of the form of action, whether in contract or tort, including negligence. Any action against National Instruments must be brought within one year after the cause of action accrues. National Instruments shall not be liable for any delay in performance due to causes beyond its reasonable control. The warranty provided herein does not cover damages, defects, malfunctions, or service failures caused by owner's failure to follow the National Instruments installation, operation, or maintenance instructions; owner's modification of the product; owner's abuse, misuse, or negligent acts; and power failure or surges, fire, flood, accident, actions of third parties, or other events outside reasonable control.

Copyright

Under the copyright laws, this publication may not be reproduced or transmitted in any form, electronic or mechanical, including photocopying, recording, storing in an information retrieval system, or translating, in whole or in part, without the prior written consent of National Instruments Corporation.

Trademarks

National Instruments, NI, ni.com, and LabVIEW are trademarks of National Instruments Corporation. Refer to the *Terms of Use* section on ni.com/legal for more information about National Instruments trademarks.

Other product and company names mentioned herein are trademarks or trade names of their respective companies.

Members of the National Instruments Alliance Partner Program are business entities independent from National Instruments and have no agency, partnership, or joint-venture relationship with National Instruments.

Patents

For patents covering National Instruments products, refer to the appropriate location: **Help»Patents** in your software, the `patents.txt` file on your CD, or ni.com/patents.

WARNING REGARDING USE OF NATIONAL INSTRUMENTS PRODUCTS

(1) NATIONAL INSTRUMENTS PRODUCTS ARE NOT DESIGNED WITH COMPONENTS AND TESTING FOR A LEVEL OF RELIABILITY SUITABLE FOR USE IN OR IN CONNECTION WITH SURGICAL IMPLANTS OR AS CRITICAL COMPONENTS IN ANY LIFE SUPPORT SYSTEMS WHOSE FAILURE TO PERFORM CAN REASONABLY BE EXPECTED TO CAUSE SIGNIFICANT INJURY TO A HUMAN.

(2) IN ANY APPLICATION, INCLUDING THE ABOVE, RELIABILITY OF OPERATION OF THE SOFTWARE PRODUCTS CAN BE IMPAIRED BY ADVERSE FACTORS, INCLUDING BUT NOT LIMITED TO FLUCTUATIONS IN ELECTRICAL POWER SUPPLY, COMPUTER HARDWARE MALFUNCTIONS, COMPUTER OPERATING SYSTEM SOFTWARE FITNESS, FITNESS OF COMPILERS AND DEVELOPMENT SOFTWARE USED TO DEVELOP AN APPLICATION, INSTALLATION ERRORS, SOFTWARE AND HARDWARE COMPATIBILITY PROBLEMS, MALFUNCTIONS OR FAILURES OF ELECTRONIC MONITORING OR CONTROL DEVICES, TRANSIENT FAILURES OF ELECTRONIC SYSTEMS (HARDWARE AND/OR SOFTWARE), UNANTICIPATED USES OR MISUSES, OR ERRORS ON THE PART OF THE USER OR APPLICATIONS DESIGNER (ADVERSE FACTORS SUCH AS THESE ARE HEREAFTER COLLECTIVELY TERMED "SYSTEM FAILURES"). ANY APPLICATION WHERE A SYSTEM FAILURE WOULD CREATE A RISK OF HARM TO PROPERTY OR PERSONS (INCLUDING THE RISK OF BODILY INJURY AND DEATH) SHOULD NOT BE RELIANT SOLELY UPON ONE FORM OF ELECTRONIC SYSTEM DUE TO THE RISK OF SYSTEM FAILURE. TO AVOID DAMAGE, INJURY, OR DEATH, THE USER OR APPLICATION DESIGNER MUST TAKE REASONABLY PRUDENT STEPS TO PROTECT AGAINST SYSTEM FAILURES, INCLUDING BUT NOT LIMITED TO BACK-UP OR SHUT DOWN MECHANISMS. BECAUSE EACH END-USER SYSTEM IS CUSTOMIZED AND DIFFERS FROM NATIONAL INSTRUMENTS' TESTING PLATFORMS AND BECAUSE A USER OR APPLICATION DESIGNER MAY USE NATIONAL INSTRUMENTS PRODUCTS IN COMBINATION WITH OTHER PRODUCTS IN A MANNER NOT EVALUATED OR CONTEMPLATED BY NATIONAL INSTRUMENTS, THE USER OR APPLICATION DESIGNER IS ULTIMATELY RESPONSIBLE FOR VERIFYING AND VALIDATING THE SUITABILITY OF NATIONAL INSTRUMENTS PRODUCTS WHENEVER NATIONAL INSTRUMENTS PRODUCTS ARE INCORPORATED IN A SYSTEM OR APPLICATION, INCLUDING, WITHOUT LIMITATION, THE APPROPRIATE DESIGN, PROCESS AND SAFETY LEVEL OF SUCH SYSTEM OR APPLICATION.

Compliance

Compliance with FCC/Canada Radio Frequency Interference Regulations

Determining FCC Class

The Federal Communications Commission (FCC) has rules to protect wireless communications from interference. The FCC places digital electronics into two classes. These classes are known as Class A (for use in industrial-commercial locations only) or Class B (for use in residential or commercial locations). All National Instruments (NI) products are FCC Class A products.

Depending on where it is operated, this Class A product could be subject to restrictions in the FCC rules. (In Canada, the Department of Communications (DOC), of Industry Canada, regulates wireless interference in much the same way.) Digital electronics emit weak signals during normal operation that can affect radio, television, or other wireless products.

All Class A products display a simple warning statement of one paragraph in length regarding interference and undesired operation. The FCC rules have restrictions regarding the locations where FCC Class A products can be operated.

Consult the FCC Web site at www.fcc.gov for more information.

FCC/DOC Warnings

This equipment generates and uses radio frequency energy and, if not installed and used in strict accordance with the instructions in this manual and the CE marking Declaration of Conformity*, may cause interference to radio and television reception. Classification requirements are the same for the Federal Communications Commission (FCC) and the Canadian Department of Communications (DOC).

Changes or modifications not expressly approved by NI could void the user's authority to operate the equipment under the FCC Rules.

Class A

Federal Communications Commission

This equipment has been tested and found to comply with the limits for a Class A digital device, pursuant to part 15 of the FCC Rules. These limits are designed to provide reasonable protection against harmful interference when the equipment is operated in a commercial environment. This equipment generates, uses, and can radiate radio frequency energy and, if not installed and used in accordance with the instruction manual, may cause harmful interference to radio communications. Operation of this equipment in a residential area is likely to cause harmful interference in which case the user is required to correct the interference at their own expense.

Canadian Department of Communications

This Class A digital apparatus meets all requirements of the Canadian Interference-Causing Equipment Regulations.

Cet appareil numérique de la classe A respecte toutes les exigences du Règlement sur le matériel brouilleur du Canada.

Compliance with EU Directives

Users in the European Union (EU) should refer to the Declaration of Conformity (DoC) for information* pertaining to the CE marking. Refer to the Declaration of Conformity (DoC) for this product for any additional regulatory compliance information. To obtain the DoC for this product, visit ni.com/certification, search by model number or product line, and click the appropriate link in the Certification column.

* The CE marking Declaration of Conformity contains important supplementary information and instructions for the user or installer.

Contents

About This Manual

How To Use the Manual Set.....	vii
Conventions	viii
Related Documentation.....	ix

Chapter 1

Introduction

About the PXI-1050 Chassis.....	1-1
What You Need to Get Started	1-1
Unpacking	1-2
Software Programming Choices	1-3
National Instruments Application Software	1-3
NI-DAQ Driver Software	1-4
Register-Level Programming	1-5
Optional Equipment	1-5
Key Features	1-5
Chassis Description.....	1-6
SCXI Subsystem Backplane Overview	1-9
PXI Subsystem Backplane Overview	1-9
Interoperability with CompactPCI	1-9
System Controller Slot	1-10
Peripheral Slots.....	1-10
Star Trigger Slot	1-10
Local Bus	1-10
SCXI Connection.....	1-11
Trigger Bus	1-11
System Reference Clock.....	1-12

Chapter 2

Installation and Configuration

Mounting Information.....	2-1
Chassis Configuration.....	2-1
SCXI Subsystem Address Selection.....	2-1
Line Voltage Selection and Fuse Values.....	2-2
PXI-1050 Chassis Installation	2-4
PXI Module Installation.....	2-4
PXI Filler Panel Installation	2-6

SCXI Module Installation.....	2-6
SCXI Filler Panel Installation	2-7
Front Filler Panel Installation	2-7
Rear Filler Panel Installation	2-7
Using the PXI Chassis Initialization File	2-7

Chapter 3 Maintenance

Maintenance Procedures.....	3-1
Service Interval	3-1
Preparation	3-1
Cleaning	3-1
Interior Cleaning.....	3-1
Exterior Cleaning.....	3-2
PXI Subsystem Fan Filter Cleaning	3-2
SCXI Subsystem Fan Filter Cleaning.....	3-2
Resetting the AC Main Circuit Breaker	3-3
SCXI Subsystem Fuse Replacement	3-4
Power Entry Module Fuse Replacement.....	3-4
SCXI Subsystem Backplane Fuse Replacement and Check.....	3-4
Troubleshooting the PXI-1050	3-5

Appendix A Specifications

Appendix B Pinouts

Appendix C Technical Support and Professional Services

Glossary

Index

About This Manual

The *PXI-1050 User Manual* describes the features of the PXI-1050 chassis and contains information about configuring the chassis, installing the modules, and operating the chassis.

How To Use the Manual Set

The *PXI-1050 User Manual* is one piece of the documentation set for your PXI system. You could have any of several types of documents, depending on the hardware and software in your system. Use the documents you have as follows:

- *Getting Started with SCXI*—This is the first manual you should read. It gives an overview of the SCXI system and contains the most commonly needed information for the modules, chassis, and software.
- Your SCXI hardware documentation—Read these next for detailed information about signal connections and module configuration. They also explain in greater detail how the module works and contain application hints.
- Your data acquisition (DAQ) hardware documentation—This documentation has detailed information about the DAQ hardware that plugs into or is connected to your computer. Use these documents for hardware installation and configuration instructions, specification information about your DAQ hardware, and application hints.
- Software documentation—You might have several sets of software documentation, including LabVIEW, LabWindows™/CVI™, and NI-DAQ. After you have set up your hardware system, use either the application software (LabVIEW or LabWindows/CVI) or the NI-DAQ documentation to help you write your application. If you have a large and complicated system, it is worthwhile to look through the software documentation before you configure your hardware.
- Accessory installation guides or manuals—If you are using accessory products, read the terminal block and cable assembly installation guides or accessory user manuals. They explain how to physically connect the relevant pieces of the system. Consult these guides when you are making your connections.
- *PXI-1050 User Manual*—Read this manual for maintenance information on the chassis and installation instructions. This manual serves as your SCXI chassis manual.

Conventions

The following conventions appear in this manual:

» The » symbol leads you through nested menu items and dialog box options to a final action. The sequence **File»Page Setup»Options** directs you to pull down the **File** menu, select the **Page Setup** item, and select **Options** from the last dialog box.



This icon denotes a note, which alerts you to important information.



This icon denotes a caution, which advises you of precautions to take to avoid injury, data loss, or a system crash.

bold Bold text denotes items that you must select or click on in the software, such as menu items and dialog box options. Bold text also denotes parameter names.

italic Italic text denotes variables, emphasis, a cross reference, or an introduction to a key concept. This font also denotes text that is a placeholder for a word or value that you must supply.

monospace Text in this font denotes text or characters that you should enter from the keyboard, sections of code, programming examples, and syntax examples. This font is also used for the proper names of disk drives, paths, directories, programs, subprograms, subroutines, device names, functions, operations, variables, filenames, and extensions.

NI-DAQ NI-DAQ is used throughout this manual to refer to the NI-DAQ software.

PXI chassis PXI chassis or simply *chassis* refers to the PXI-1050.

SCXIBus SCXIBus refers to the backplane in the chassis SCXI subsystem. A signal on the backplane is referred to as the SCXIBus <signal name> line (or signal). The SCXIBus descriptor may be omitted when the meaning is clear.

Slot 0 Slot 0 refers to the power supply and control circuitry in the SCXI subsystem.

Related Documentation

The following document contains information that you might find helpful as you read this manual:

- Your computer technical reference manual

If you are designing your own module, the following National Instruments specification, available by request, describes the physical, electrical, and timing requirements for PXI:

- *PXI Specification*, Revision 2.1

Introduction

This chapter describes the PXI-1050, lists what you need to get started, describes the optional equipment, and explains how to unpack the PXI-1050 chassis.

About the PXI-1050 Chassis

Thank you for purchasing the National Instruments PXI-1050 chassis. This chassis integrates a high-performance 8-slot PXI subsystem with a 4-slot SCXI subsystem to offer a complete solution for signal conditioning applications. The PXI section of the chassis accepts an embedded controller and a wide variety of peripheral modules (such as multifunction I/O, digital I/O, and instrument modules). The four SCXI slots integrate signal conditioning modules into your PXI system. These modules provide analog and digital input conditioning, isolation, and other functions. The PXI-1050 is ideal for applications where rack-mount space is limited because it combines the computer, plug-in devices, and signal conditioning in a single chassis. You can daisy-chain additional SCXI chassis to the PXI-1050 to build very high channel-count systems.

What You Need to Get Started

To set up and use your PXI-1050 chassis, you will need the following items:

- PXI-1050 chassis
- Power cable (refer to Table 1-1)
- PXI-1050 Chassis User Manual*
- One of the following software packages and documentation:
 - BridgeVIEW
 - ComponentWorks
 - LabVIEW for Windows
 - LabWindows/CVI for Windows

- Measure
- NI-DAQ for PC compatibles
- VirtualBench
- PXI Chassis Initialization File for PXI-1050, version 1.0 (CD) with `chassis.ini`
- PXI system controller and software
- PXI DAQ module
- SCXI module
- Flathead screwdriver
- Needle-nose pliers

Table 1-1. Power Cables

Power Cable	Reference Standards
Standard 120 V (USA)	ANSI C73.11/NEMA 5-15-P/IEC83
Switzerland 220 V	SEV
Australia 240 V	AS C112
Universal Euro 240 V	CEE (7), II, IV, VII IEC83
North America 240 V	ANSI C73.20/NEMA 5-15-P/IEC83
United Kingdom 240 V	BS 1363/IEC83

If you are missing any of the items listed or if you have the incorrect power cable, contact National Instruments.

Unpacking

Carefully inspect the shipping container and the chassis for damage. Check for visible damage to the metal work. Check to make sure all handles, hardware, and switches are undamaged. Inspect the inner chassis for any possible damage, debris, or detached components. If damage appears to have been caused in shipment, file a claim with the carrier. Retain the packing material for possible inspection and/or reshipment.

Software Programming Choices

You have several options to choose from when programming your National Instruments DAQ and SCXI hardware. You can use National Instruments application software, NI-DAQ, or register-level programming.

National Instruments Application Software

ComponentWorks contains tools for data acquisition and instrument control built on NI-DAQ driver software. ComponentWorks provides a higher-level programming interface for building virtual instruments through standard OLE controls and DLLs. With ComponentWorks, you can use all of the configuration tools, resource management utilities, and interactive control utilities included with NI-DAQ.

LabVIEW features interactive graphics, a state-of-the-art user interface, and a powerful graphical programming language. The LabVIEW Data Acquisition VI Library, a series of VIs for using LabVIEW with National Instruments DAQ hardware, is included with LabVIEW. The LabVIEW Data Acquisition VI Library is functionally equivalent to NI-DAQ software.

LabWindows/CVI features interactive graphics, state-of-the-art user interface, and uses the ANSI standard C programming language. The LabWindows/CVI Data Acquisition Library, a series of functions for using LabWindows/CVI with National Instruments DAQ hardware, is included with the NI-DAQ software kit. The LabWindows/CVI Data Acquisition Library is functionally equivalent to the NI-DAQ software.

VirtualBench features virtual instruments that combine DAQ products, software, and your computer to create a stand-alone instrument with the added benefit of the processing, display, and storage capabilities of your computer. VirtualBench instruments load and save waveform data to disk in the same forms that can be used in popular spreadsheet programs and word processors.

Using ComponentWorks, LabVIEW, LabWindows/CVI, or VirtualBench software will greatly reduce the development time for your data acquisition and control application.

NI-DAQ Driver Software

The NI-DAQ driver software is included at no charge with all National Instruments DAQ hardware. NI-DAQ has an extensive library of functions that you can call from your application programming environment. These functions include routines for analog input (A/D conversion), buffered data acquisition (high-speed A/D conversion), analog output (D/A conversion), waveform generation, digital I/O, counter/timer operations, SCXI, PXI Trigger Bus (RTSI), self-calibration, messaging, and acquiring data to extended memory.

NI-DAQ also internally addresses many of the complex issues between the computer and the plug-in board, such as programming interrupts and DMA controllers. NI-DAQ maintains a consistent software interface among its different versions so that you can change platforms with minimal modifications to your code. Whether you are using conventional programming languages or National Instruments application software, your application uses the NI-DAQ driver software, as illustrated in Figure 1-1.

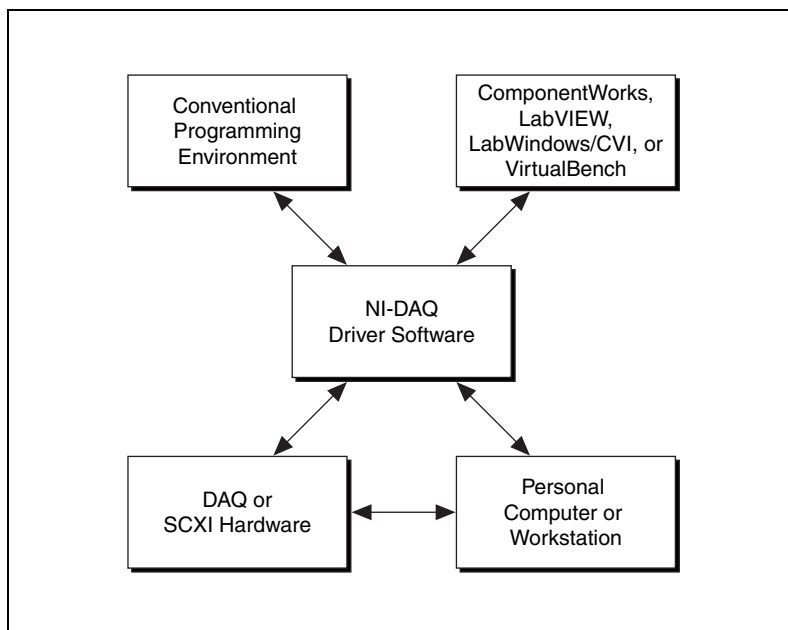

Figure 1-1. The Relationship among the Programming Environment, NI-DAQ, and Your Hardware

Register-Level Programming

Another option for programming any National Instruments DAQ hardware is to write register-level software. Writing register-level programming software can be very time-consuming and inefficient and is not recommended.

Even if you are an experienced register-level programmer, consider using National Instruments application software to program your National Instruments DAQ hardware. Using National Instruments application software is easier than and as flexible as register-level programming and can save weeks of development time.

Optional Equipment

National Instruments offers a variety of products to use with your PXI-1050 chassis, including cables and other accessories, as follows:

- Cables and cable accessories, shielded and ribbon
- Shielded and unshielded 68- and 100-pin screw terminals
- SCXI modules and accessories for isolating, amplifying, exciting, and multiplexing signals for relays and analog output
- PXI modules and accessories for multifunction I/O and instrumentation

For more specific information about these products, refer to your National Instruments catalog or call the office nearest you.

Key Features

The PXI-1050 combines a high-performance 8-slot PXI subsystem with a 4-slot SCXI subsystem. The PXI-1050 has a structural design that is optimized for maximum use in a wide range of applications. The PXI-1050 fully complies with the *PXI Specification*, Revision 2.1, offering advanced timing and synchronization features.

The SCXI subsystem supplies a low-noise environment for signal conditioning, supplying power and control circuitry for the SCXI modules. Use this general-purpose chassis with current and future SCXI modules.

The PXI-1050 has a built-in interconnect between the PXI and SCXI subsystems that allows a DAQ device in the eighth PXI slot to control the SCXI subsystem without additional cables.

Chassis Description

Figure 1-2 shows the front view of the PXI-1050. Table 1-2 describes the front view items.

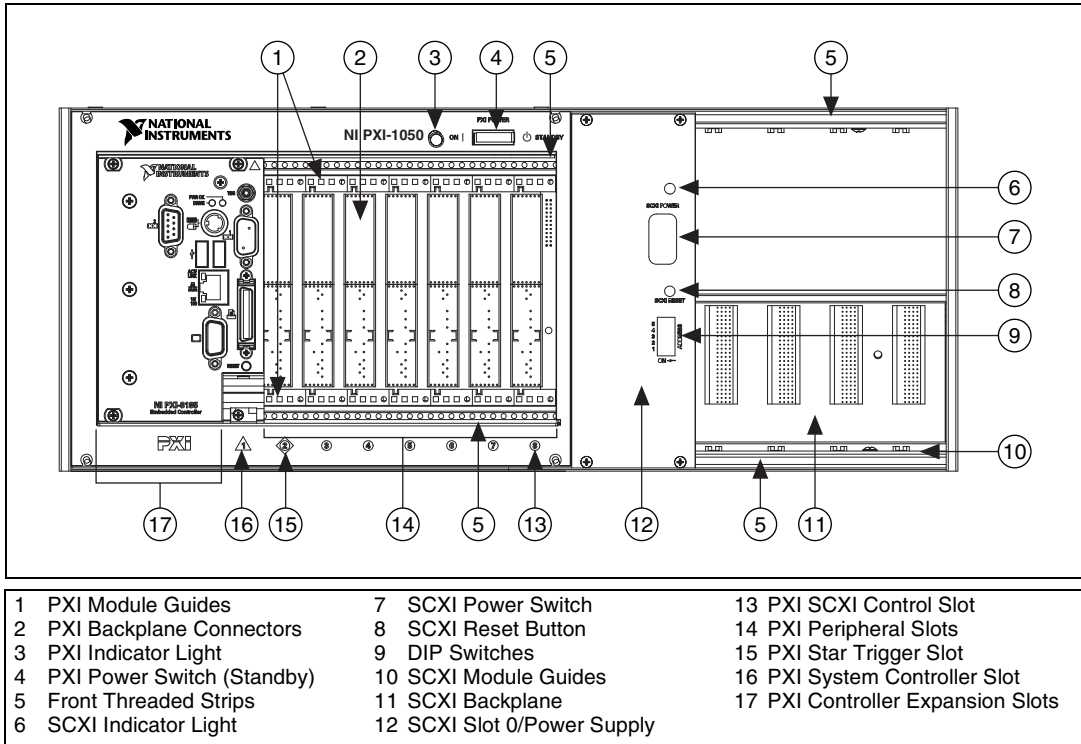

Figure 1-2. Front View of the PXI-1050 Chassis

Table 1-2. PXI-1050 Chassis Front View Items

Item	Description
PXI module guides	Guide PXI modules to mate with PXIbus connectors
PXI backplane connectors	Connect PXI modules to the PXIbus
PXI indicator light	When lit, indicates that the PXI subsystem is powered on
PXI power switch	Turns the PXI subsystem on and off
Front-threaded strips	Secure modules in the chassis and attach front panels
SCXI indicator light	When lit, indicates that the SCXI subsystem is powered on

Table 1-2. PXI-1050 Chassis Front View Items (Continued)

Item	Description
SCXI power switch	Turns the SCXI subsystem on and off
SCXI reset button	Reinitializes Slot 0 and all SCXI modules to their power-on state when pressed
DIP switches	Determine the SCXI subsystem address
SCXI module guides	Guide modules to mate with the SCXIbus connector
SCXI backplane	Brings power, control lines, and analog bus connections to SCXI modules
SCXI Slot 0/power supply	Contains the power supply and control circuitry for the SCXI subsystem
PXI SCXI Control slot	Device in this slot can control SCXI subsystem
PXI peripheral slots	Hold PXI peripheral modules
PXI Star Trigger slot	Holds PXI star trigger controller or any PXI peripheral module
PXI System Controller slot	Holds PXI system controller
PXI controller expansion slots	Provide space for large controllers

Figure 1-3 shows the chassis rear view items that are then described in Table 1-3.

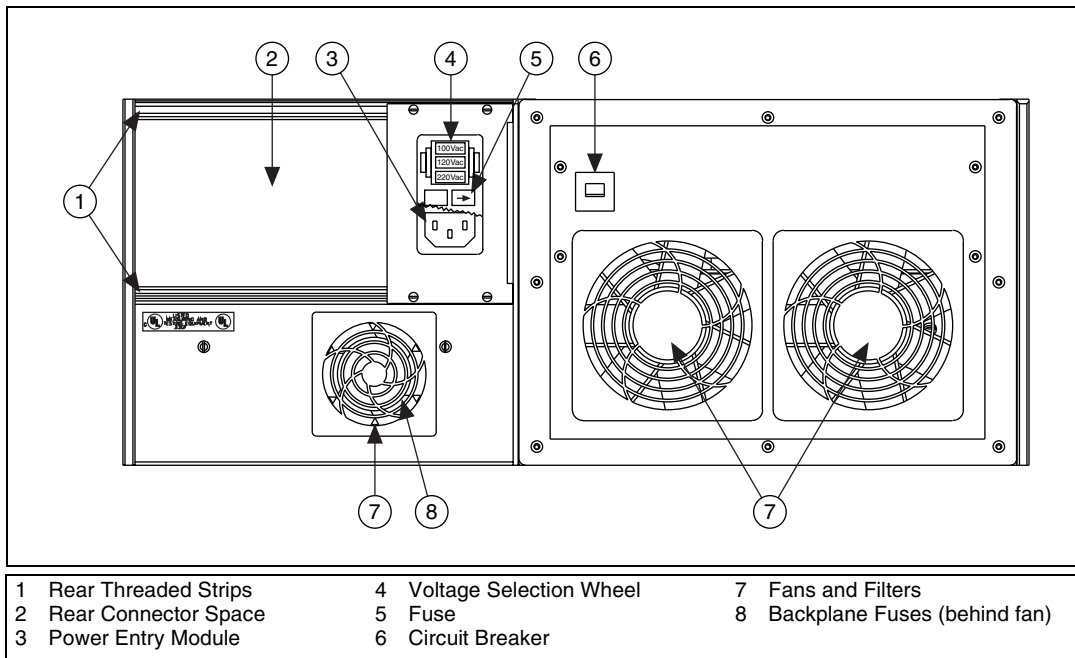

Figure 1-3. Rear View of the PXI-1050 Chassis

Table 1-3. PXI-1050 Chassis Rear View Items

Item	Description
Rear threaded strips	Secure cable connections, mounting brackets, or filler panels to the chassis
Rear connector space	For module space, connector mounting brackets, or adapter boards
Power entry module	IEC receptacle for power input, voltage selection wheel, and fuse
Voltage selection wheel	Configures the chassis for the AC line voltage
Fuse	Protects both you and the SCXI subsystem in case of a fault in the SCXI subsystem
Circuit breaker	Protects both you and the PXI subsystem in case of a PXI subsystem fault
Fans and filters	Cool the chassis; prevent dirt from contaminating the chassis circuitry
Backplane fuses	Protect the SCXI subsystem power supply from module shorts

SCXI Subsystem Backplane Overview

You can use the SCXI subsystem in the following ways:

- Install several SCXI modules and a PXI DAQ device in Slot 8 of the PXI backplane to control and/or acquire data from all the SCXI modules.
- Install several SCXI modules and cable one of them to a DAQ device that controls and/or acquires data from all of the SCXI modules.
- Install several SCXI modules and an SCXI-1200 module that operates similarly to a DAQ device, except that it communicates with the host computer through a parallel port instead of the computer plug-in bus.
- Install SCXI modules that are each dedicated to conditioning signals for only a single DAQ device (for example, in parallel mode), or that operate independently and only use the SCXI subsystem as a power source and/or container. You can use the chassis this way in addition to or instead of one of the first three methods.

PXI Subsystem Backplane Overview

The following sections describe the PXI subsystem backplane.

Interoperability with CompactPCI

The PXI backplane is interoperable with PXI-compatible products and standard CompactPCI products. This is an important feature, because many PXI-compatible systems may require components that do not implement PXI-specific features.

For example, you may want to use a standard CompactPCI network interface card in a PXI chassis. The signals on the PXI-1050 backplane P1 connector meet the requirements of the CompactPCI specification for both the peripheral and system modules. The PXI-specific signals are located on the P2 connector and are found only on the signals that are reserved or not used in the CompactPCI 64-bit specification. Therefore, all modules that meet the CompactPCI 64-bit specification requirements will function in the PXI-1050.

System Controller Slot

The System Controller slot is located in Slot 1 of the chassis as defined by the PXI specification. It has three controller expansion slots, which are used for system controller modules wider than one slot. As defined in the PXI specification, these slots allow the controller to expand to the left so it does not use up peripheral slots.

Peripheral Slots

The PXI-1050 has seven peripheral slots located in Slots 2 through 8. You can use PXI modules in peripheral slots to add functionality to the PXI subsystem not already provided by the system controller. Examples of PXI peripheral modules are multifunction I/O, digital I/O, and instrument modules. Some peripheral slots also have special capabilities, such as the Star Trigger slot and the SCXI Control slot, which are explained in the following sections.

Star Trigger Slot

The Star Trigger slot is located at Slot 2. This slot has a dedicated trigger line between each peripheral slot (refer to Figure 1-4) and is intended for modules with Star Trigger functionality to provide individual triggers to all other peripherals. However, if you do not require advanced trigger functionality, you can install any standard peripheral module into this slot.

Local Bus

The PXI backplane local bus is a daisy-chained bus that connects each peripheral slot with its adjacent left and right peripheral slots, as shown in Figure 1-4.

For example, a given peripheral slot's right local bus connects to the adjacent slot's left local bus and so on. Each local bus is 13 lines wide and can pass analog signals between modules or provide a high-speed side-band communication path that does not affect the PXI bandwidth.

Local bus signals may range from high-speed TTL signals to analog signals as high as 42 V. Initialization software keys adjacent modules to prohibit the use of incompatible devices. This software uses the configuration information specific to each peripheral module to evaluate compatibility. This method is a flexible way to define local bus functionality that is not limited by keying hardware.

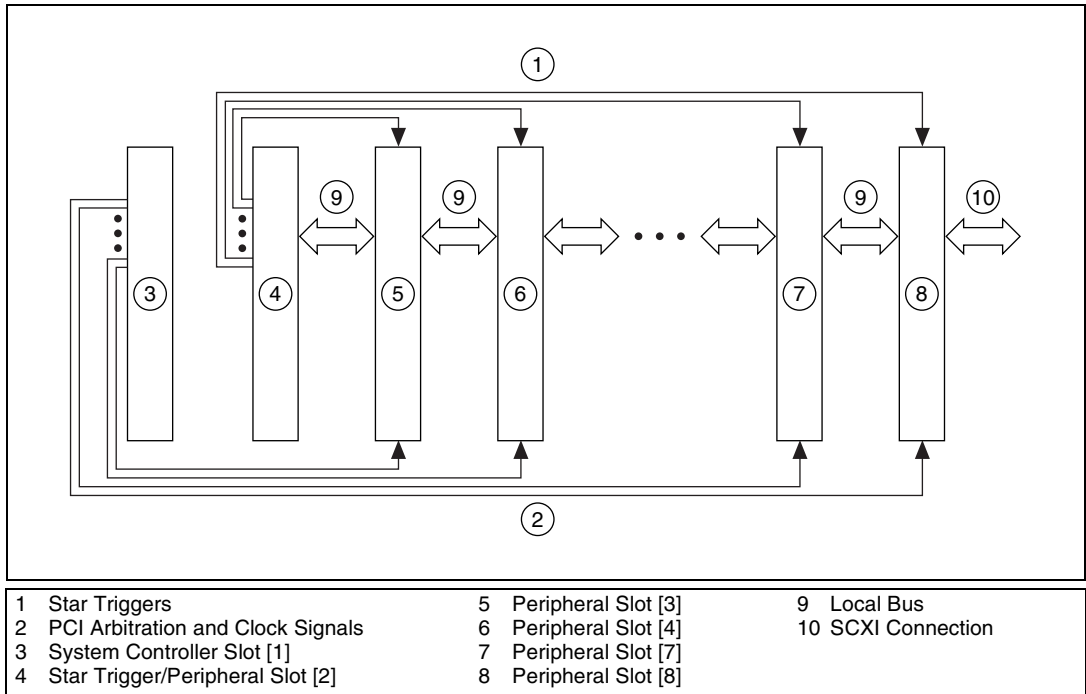

Figure 1-4. PXI Star Trigger and Local Bus Routing

SCXI Connection

Slot 8 of the PXI backplane has connections for a PXI peripheral module to control the SCXI subsystem. These connections use the available local bus right pins (PXI_LBR0:12). The SCXI connection passes communication, timing, and analog signals between the SCXI backplane and the PXI module in Slot 8.

Trigger Bus

The eight PXI trigger lines are bused to each slot. You can use the trigger lines in a variety of ways. For example, you can use triggers to synchronize the operation of several different PXI peripheral modules. In other applications, one module can control carefully timed sequences of operations performed on other modules in the system. Modules can pass triggers to one another, allowing precisely timed responses to asynchronous external events the system is monitoring or controlling.

System Reference Clock

The PXI-1050 supplies the PXI 10 MHz system clock signal (PXI_CLK10) independently to each peripheral slot. An independent buffer (having a source impedance matched to the backplane and a skew of less than 1 ns between slots) drives the clock signal to each peripheral slot. You can use this common reference clock signal to synchronize multiple modules in a measurement or control system. You can drive PXI_CLK10 from an external source through the PXI_CLK10_IN pin on the P2 connector of the Star Trigger slot. (Refer to Table B-4, [P2 \(J2\) Connector Pinout for the Star Trigger Slot](#).) Sourcing an external clock on this pin automatically disables the backplane 10 MHz source.

Installation and Configuration

This chapter describes how to prepare and operate your PXI-1050 chassis.

Mounting Information

The PXI-1050 is designed to operate on a bench or in an instrument rack. Determine how you want to use your PXI-1050 and follow the appropriate installation instructions.

Apertures in the rear, along both sides, and on top of the chassis facilitate power supply and module cooling. Air enters through filters and fan inlets located in the lower rear of the chassis and exits through the upper side sections and through the top. Place your PXI-1050 on a bench top or in an instrument rack so that the fans (air inlets) and the air outlet apertures along both sides of the chassis have adequate ventilation. Keep other equipment a minimum of 3.0 in. (76.2 mm) away from the air inlets and outlets.

Install your chassis for easy access to the rear panel. This simplifies the air filter replacement.

Rack-mount applications require the optional rack-mount kit available from National Instruments. Refer to the rack-mount kit documentation to install your PXI-1050 in an instrument rack.

Chassis Configuration

Chassis configuration involves selecting an SCXI subsystem address, line voltage, and fuse value, described briefly in the following sections.

SCXI Subsystem Address Selection



Note Unless you are using multiple chassis and need to configure one or more SCXI chassis for a different address, you can skip this section. The SCXI subsystem will have the factory-default address of 0.

You can configure the SCXI subsystem for one of 32 different addresses so that you can connect multiple SCXI chassis to the same control source. The five switches on the front panel of Slot 0 determine the chassis address. Switches one through five represent the values 1, 2, 4, 8, and 16 respectively, when set to the ON position. When set to the OFF position, their value is 0. The chassis address is the sum of the switch values. Figure 2-1 shows examples of both the factory-default setting of the chassis address 0 and the switch setting for chassis address 19.

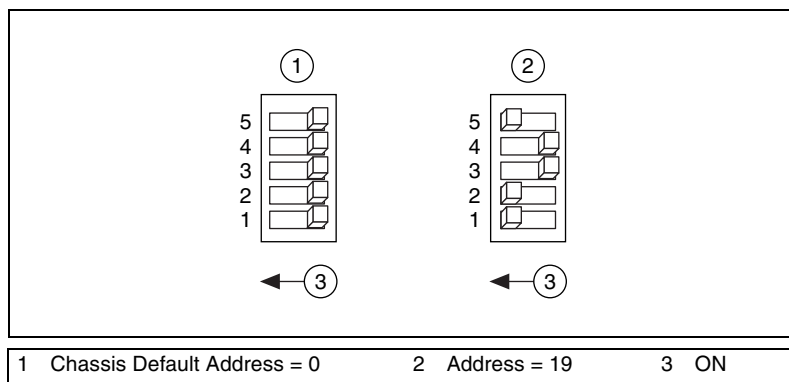

Figure 2-1. Address Setting Examples

Line Voltage Selection and Fuse Values

The voltage selection wheel and fuse should be correct for operation in your geographical region (the -0x extension of the kit part number corresponds to your geographical region). Check the voltage on the voltage selection wheel to ensure that you have the correct voltage setting and fuse.

The PXI-1050 chassis can operate with line voltages of 100, 120, 220, and 240 VAC. The voltage selection wheel in the power entry module determines the voltage for which the chassis is configured. Identify the operating voltage by looking at the number on the power entry module when the selection wheel door is closed. The fuse is a 5 by 20 mm SLO-BLO type, which has a current rating relative to the operating voltage. Table 2-1 shows the proper voltage selection and fuse ratings for different geographical regions.



Caution For continued protection against fire, replace fuses only with fuses of the same type and rating.

Table 2-1. PXI-1050 Voltage Selection and Fuse Ratings by Region

Region	Line Voltage	Fuse Rating
North America	120 VAC	1/2 A
Japan	100 VAC	3/4 A
Europe	240 VAC	1/4 A
Switzerland	220 VAC	1/4 A

Table 2-2 shows the manufacturer part numbers National Instruments uses for these fuses.

Table 2-2. PXI-1050 Fuse Part Numbers

Fuse Rating	Manufacturer	Part Number
1/4 A	Littelfuse	218.250
1/2 A	Littelfuse	239.500
3/4 A	Littelfuse	239.750

To select a line voltage, refer to Figure 1-3, *Rear View of the PXI-1050 Chassis*, as needed and complete the following steps:

1. Turn off the PXI-1050 power.
2. Remove the power cable from the power-entry module.
3. Using a flathead screwdriver, pry the door to the selection wheel open from the top.
4. Remove the selection wheel.
5. Rotate the wheel for the appropriate voltage and reinsert it into the power-entry module.
6. Close the door.
7. Check that the voltage showing on the selection wheel is correct.
8. Reinsert the power cable.

PXI-1050 Chassis Installation



Caution Equipment described in this document must be used in a Measurement Category II environment per IEC 644. This category requires local level supply mains-connected installation.

Complete the following steps to install the PXI-1050 chassis:

1. If you are *not* using multiple chassis, skip this step and leave the address at its factory-default setting of 0. If you are using multiple chassis, change the SCXI chassis address of the SCXI subsystem by following the instructions in the [SCXI Subsystem Address Selection](#) section earlier in this chapter.
2. Place the PXI chassis on a sturdy, level surface. Leave at least 10 cm (4 in.) of space behind the chassis for adequate air circulation.
3. Turn off the power switches.
4. Check that the voltage selection wheel in the power-entry module is set for your outlet line voltage. Refer to the [Line Voltage Selection and Fuse Values](#) section earlier in this chapter, if necessary.
5. Insert the female end of your power cable into the power-entry module.
6. Insert the male end of your power cable into the wall outlet.
7. Install the SCXI and PXI modules into the chassis (refer to the appropriate sections later in this chapter).

If you are *not* using a DAQ device in Slot 8 of the PXI backplane to control the SCXI modules, install the necessary cabling for your modules. Consult your SCXI module documentation for cabling installation instructions.

8. Install any front and rear filler panels (refer to the appropriate sections later in this chapter).
9. Turn on the chassis power switches.

PXI Module Installation



Caution Turn off the PXI subsystem power using the power switch shown in Figure 1-2, [Front View of the PXI-1050 Chassis](#), before installing CompactPCI or PXI modules.

Complete the following steps to install a PXI module into a chassis slot:

1. Place the module edges into the PXI module guides (top and bottom), as shown in Figure 1-2, *Front View of the PXI-1050 Chassis*.
2. Slide the module to the rear of the chassis, making sure that the injector/ejector handle is pushed down as shown in Figure 2-3.
3. When you begin to feel resistance, push up on the injector/ejector handle to inject the module into the frame.
4. Secure the module's front panel to the chassis using the module front-panel mounting screws.

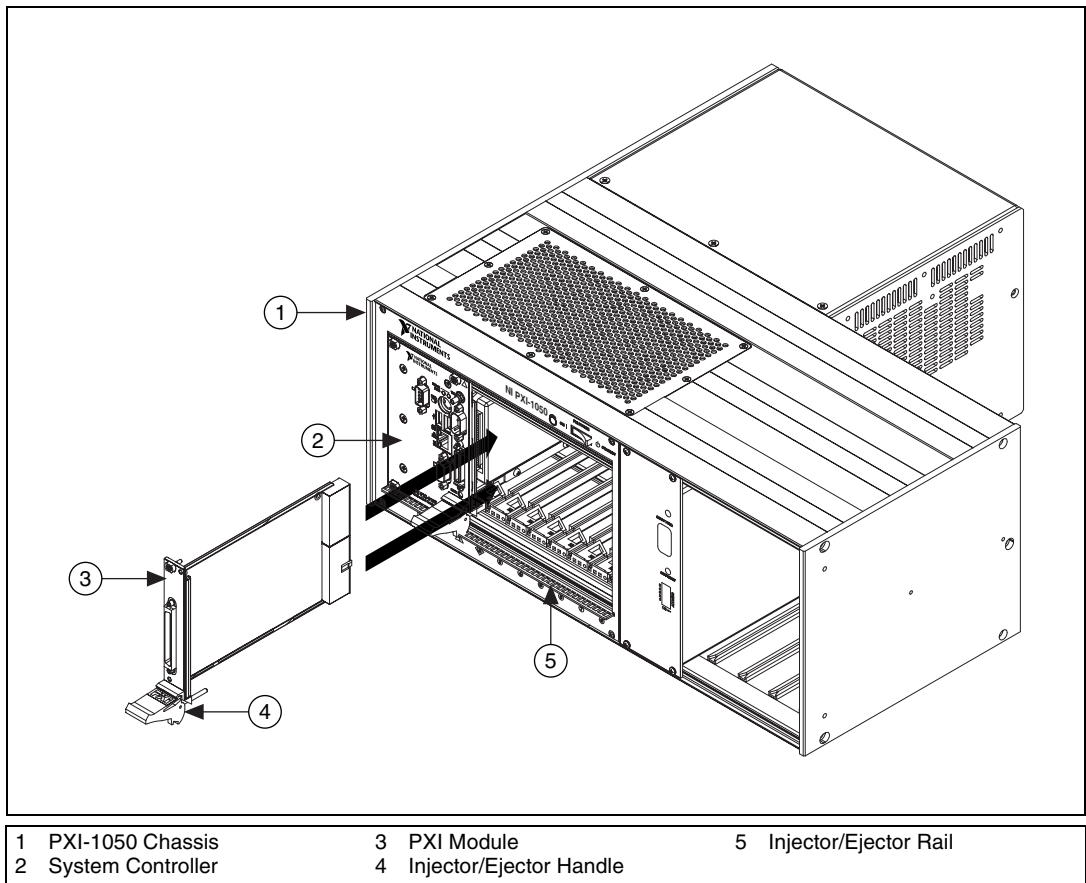

Figure 2-2. Installing PXI or CompactPCI Modules (PXI Module Shown)

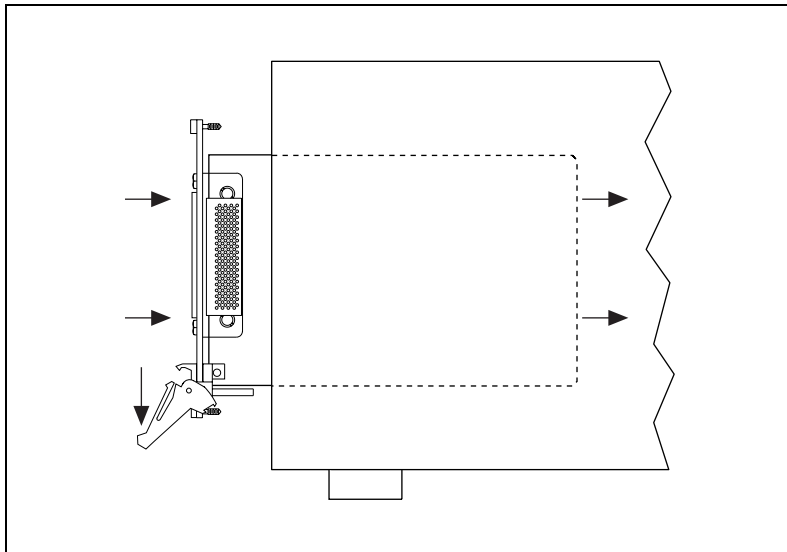

Figure 2-3. Injector/Ejector Handle Position during Module Insertion

PXI Filler Panel Installation

To optimize module cooling performance, install filler panels into unused or empty slots. Secure the filler panels with the captive mounting screws.

SCXI Module Installation

Complete the following steps to install SCXI modules:

1. Power off the SCXI subsystem using the switch shown in Figure 1-2, *Front View of the PXI-1050 Chassis*.
2. Remove the front filler panel of an empty SCXI slot.
3. Insert the module into the module guide rails and slide the module to the back of the chassis. Do *not* force the module into place.
4. Screw the front mounting panel of the module to the top and bottom threaded strips of the SCXI chassis using the thumbscrews on the module front panel.
5. Install any necessary cabling.

The installation is complete.

Refer to your SCXI module documentation for specific instructions pertaining to the module, especially module cabling.

SCXI Filler Panel Installation

The SCXI front and rear filler panel accessories protect the inside of the SCXI subsystem and installed modules by preventing unwanted material from entering the PXI chassis and damaging modules or forming conductive paths that may degrade performance. Install all SCXI modules first, then, in any unused SCXI slots, install filler panels from the edge of the module front panels.

Front Filler Panel Installation

Front filler panels are the height of a full slot. Complete the following steps to install SCXI front filler panels:

1. Place the filler panel with the captive screws to the right of the PXI chassis front. Line up the screws with the threaded strip holes.
2. Using a flathead screwdriver, screw the two captive screws into the threaded strip holes.

Rear Filler Panel Installation

Rear filler panels are half the height of front filler panels. To install SCXI rear filler panels, complete the following steps:

1. Place the filler panel at the rear of the chassis between the two threaded strips. Align the filler panel so that the serial number faces into the chassis and the screw holes are on the right of the rear panel.
2. Using a flathead screwdriver, screw the two screws through the rear panel into the threaded strip holes.

Using the PXI Chassis Initialization File

To assist system integrators, the PXI specification requires manufacturers of PXI chassis and system modules to document their product capabilities. The minimum documentation requirements are in `.ini` files, which consist of ASCII text. The system integrator can read the `.ini` file, and configuration utilities and device drivers can also use this file. The PXI-1050 chassis initialization file, `chassis.ini`, is included on the media for your PXI-1050.

Maintenance

This chapter describes basic maintenance procedures for the PXI-1050 chassis.

Maintenance Procedures

Service Interval

Clean the chassis fan filters at a maximum interval of six months. Depending upon the amount of use and ambient dust levels in the operating environment, the filters may require more frequent cleaning.

Clean dust from the chassis exterior and interior as needed, based on the operating environment. Periodic cleaning increases reliability.

Preparation

The information in this section is designed for use by qualified service personnel.



Caution Many components within the chassis are susceptible to static discharge damage. Service the chassis only in a static-free environment. Observe standard handling precautions for static-sensitive devices while servicing the chassis. Always wear a grounded wrist strap or equivalent while servicing the chassis.

Cleaning

Cleaning procedures consist of cleaning the exterior and interior of the chassis and fan filters. Refer to your PXI module documentation for information on cleaning the individual CompactPCI or PXI modules.



Caution Always power off the chassis and disconnect the power cable before cleaning or servicing the chassis.

Interior Cleaning

Use a dry, low-velocity stream of air to clean the chassis interior. Use a soft-bristle brush for cleaning around components.

Exterior Cleaning

Clean the exterior surfaces of the chassis with a dry lint-free cloth or a soft-bristle brush. If any dirt remains, wipe with a cloth moistened in a mild soap solution. Remove any soap residue by wiping with a cloth moistened with clear water.



Cautions Do *not* use abrasive compounds on any part of the chassis.

Avoid getting moisture inside the chassis during exterior cleaning.

Do *not* wash the front- or rear-panel connectors or switches. Cover these components while cleaning the chassis.

Do *not* use chemical cleaning agents: they may damage the chassis. Avoid chemicals that contain benzene, toluene, xylene, acetone, or similar solvents.

PXI Subsystem Fan Filter Cleaning

To easily remove the chassis cooling filters from the rear of the chassis, remove the plastic housing attached to each fan.

To clean the fan filters, wash them in a mild soap solution and then vacuum or blow air through them. Rinse the filters with water and allow them to dry before reinstalling them onto the chassis.

SCXI Subsystem Fan Filter Cleaning

The fan on the rear of the SCXI subsystem cools the SCXI subsystem and its modules. To keep the fan effective, the fan filters must be clean. Dust and dirt accumulation reduces airflow, which makes the inside of the chassis hotter, shortening the life of the chassis and modules. Complete the following steps to clean the fan filters:

1. Power off the chassis.
2. Remove the power cable from the power-entry module.
3. Place the chassis face down on a flat surface so that the fan is on top. If the chassis is so heavily cabled that you cannot practically place it in this position, leave the chassis as it is but be careful to support the fan during removal and reinstallation to prevent breaking the fan wires.

To remove the fan filter, remove the four screws that secure the fan and filter to the rear of the chassis. When removing the last screw, be careful to hold the fan to prevent breaking the fan wires.

4. Clean the fan filter by moving the filter around under a gentle stream of cold tap water until all the dust has been removed. Dry the filter.
5. Replace the fan filter by aligning the fan and filter with the fan holes, making sure that the label side of the fan is face down. Reinstall the four screws and make sure the assembly is secure.

Resetting the AC Main Circuit Breaker

If your PXI subsystem encounters an over-current condition, the circuit breaker located on the rear panel will trip to prevent chassis damage. Refer to Figure 1-2, *Front View of the PXI-1050 Chassis*, and Figure 1-3, *Rear View of the PXI-1050 Chassis*, as you complete the following steps:

1. Turn off the PXI power switch.
2. Depress the circuit breaker to reset it.
3. Turn on the PXI power switch.

If the circuit breaker trips again, complete the following steps:

1. Turn off the PXI power switch.
2. Remove all modules from the chassis.
3. Depress the circuit breaker to reset it.
4. Turn on the power switch and verify that the circuit breaker does not trip.
5. Verify that your PXI-1050 can meet the power requirements of your CompactPCI or PXI modules. Overloading the chassis can cause the breaker to trip. Refer to Appendix A, *Specifications*, for power requirements.
6. The over-current condition that caused the circuit breaker to trip may be due to a faulty CompactPCI or PXI module. Refer to your module documentation to troubleshoot your modules.

SCXI Subsystem Fuse Replacement

Power Entry Module Fuse Replacement



Caution Disconnect all power before removing cover.

Refer to Figure 1-3, *Rear View of the PXI-1050 Chassis*, as you complete the following steps to replace the power-entry module fuse:

1. Power off the chassis.
2. Remove the power cable from the power-entry module.
3. Using a flathead screwdriver, pry the door to the voltage selection wheel open from the top.
4. Pull out the fuse drawer.
5. Remove the fuse.
6. Install the new fuse in the drawer.
7. Reinsert the fuse drawer in the right side slot with the arrow pointing to the right.
8. Close the door.
9. Reinsert the power cable.

SCXI Subsystem Backplane Fuse Replacement and Check

In addition to the power entry module fuse, the analog supply lines on the backplane are fused at 1.5 A. The fuse manufacturer is Littelfuse, part number 251 01.5.

If you are going to make your own modules, fuse your module at 250 mA to avoid blowing the backplane fuses. Fusing your module also better protects your module because a failure can result in a large amount of current drawn, but not enough to blow the backplane fuses.

The backplane fuses are located behind the SCXI subsystem fan.

Complete the following steps to check or replace fuses:

1. Remove the appropriate fan and filter from the rear of the chassis, following the instructions in the *SCXI Subsystem Fan Filter Cleaning* section in this chapter. Make sure to power off the chassis and remove the power cable.
2. The fuse marked with a copper + on the backplane is for the positive analog supply, and the fuse marked with a copper – is for the negative

- analog supply. To check whether a fuse is blown, connect an ohmmeter across the leads. If the reading is not $0\ \Omega$, replace the fuse.
3. Use a pair of needle-nose pliers to carefully extract the fuse.
 4. Take a new fuse and bend its leads so the component is 1.27 cm (0.5 in.) long (the dimension between the fuse sockets), and clip the leads to a length of 0.635 cm (0.25 in).
 5. Using the needle-nose pliers, insert the fuse into the socket holes.
 6. Repeat, if necessary, for the other fuse.
 7. Check the fan filter and, if it is dirty, clean it as described in the [SCXI Subsystem Fan Filter Cleaning](#) section of this chapter.
 8. Reinstall the fan and filter.

Troubleshooting the PXI-1050

Refer to Table 3-1 to troubleshoot the PXI-1050 chassis. The table lists possible causes for power failure and recommends ways to correct the problem.

Table 3-1. Troubleshooting Power Failure

Possible Cause	What to Do
PXI-1050 chassis is not connected to power source.	Make sure that the PXI-1050 is connected to a live electrical outlet. Try operating another piece of equipment from this outlet.
Power switch is not switched on.	Set the PXI power switch to the <i>On</i> position.
Circuit breaker is tripped.	Reset the circuit breaker. Refer to the Resetting the AC Main Circuit Breaker section of this chapter.
Power supply has failed.	Contact National Instruments.

Specifications

This appendix contains complete specifications for the PXI-1050 chassis.

PXI Subsystem Electrical Characteristics

AC Input

Input voltage range..... 100/120/220/240 VAC

Operating voltage range¹..... Refer to Table A-1 for ranges determined by user configuration

Input frequency 50/60 Hz

Operating frequency range¹ 47 to 63 Hz

Table A-1. PXI-1050 Voltage Ranges, Current, and Fuse Ratings by User Configuration

Line Voltage Selection	Range (VAC)	Current (MAX)	Fuse, 250 V, 5 × 20 mm
100 VAC	90–110	8 A	.75 A Slow
120 VAC	108–132	8 A	.5 A Slow
220 VAC	198–242	4 A	.25 A Slow
240 VAC	216–264	4 A	.25 A Slow

Line regulation

3.3 V..... <±0.2%

5 V..... <±0.1%

±12 V <±0.1%

Efficiency 70% typical

¹ The operating range is guaranteed by design.

Power disconnectThe AC power cable provides main power disconnect. The front-panel power switch causes the internal chassis power supply to provide DC power to the CompactPCI/PXI backplane.

PXI Subsystem DC Output

DC current capacity

Voltage	I _{MP} (Steady-state current)
+3.3 V	30 A
+5 V	20 A
+12 V	4 A
-12 V	2 A

Load regulation

Voltage	Load Regulation
+3.3 V	<5%
+12 V	<5%
+5 V	<5%
-12 V	<5%

Maximum ripple and noise (20 MHz bandwidth)

Voltage	Maximum Ripple and Noise
+3.3 V	50 mV _{pp}
+12 V	120 mV _{pp}
+5 V	50 mV _{pp}
-12 V	120 mV _{pp}

Over-current protectionAll outputs protected from short circuit and overload with automatic recovery

Over-voltage protection	
3.3 V and 5 V	Clamped at 20 to 30% above nominal output voltage
+12 V and -12 V	Clamped at 26 to 29 V difference between +12 and -12 V outputs

SCXI Subsystem Electrical Characteristics

DC Output

V+ output

Tolerance limits include peaks	+18.5 to +25 V
Ripple (peak-to-peak)	1.5 V
Max load	680 mA

V- output

Tolerance limits include peaks	-18.5 to -25 V
Ripple (peak-to-peak)	1.5 V
Max load	680 mA

+5 V output

Tolerance limits include peaks	+4.75 to +5.25 V
Ripple (peak-to-peak)	50 mV
Max load	200 mA

Maximum loads are the supply current for the entire chassis. Scaling the maximum power gives the allotted current per slot, as follows:

V+ output	170 mA
V- output.....	170 mA
+5 V output	50 mA

PXI Subsystem Cooling

Per slot cooling capacity	Slot cooling capacity in worst-case slot is 25 W
Module cooling system	Forced air circulation (positive pressurization) through two fans

Slot airflow direction	P1 to P2, bottom of module to top of module
Module cooling intake	Bottom rear of chassis
Module cooling exhaust.....	Along sides and top of chassis
Power supply cooling system	Forced air circulation from integrated fan
Power supply cooling intake.....	Rear of chassis
Power supply cooling exhaust	Sides of chassis
Module cooling fan MTBF.....	30,000 h

Environmental

Operating location	Indoor use
Maximum altitude.....	2,000 m
Measurement Category.....	II
Pollution Degree	2

Operating Environment

Ambient temperature range	0 to 50 °C (Tested in accordance with IEC-60068-2-1 and IEC-60068-2-2.)
Relative humidity range.....	10 to 90%, noncondensing (Tested in accordance with IEC-60068-2-56.)

Storage Environment

Ambient temperature range	-20 to 70 °C (Tested in accordance with IEC-60068-2-1 and IEC-60068-2-2.)
Relative humidity range.....	5 to 95%, noncondensing (Tested in accordance with IEC-60068-2-56.)

Shock and Vibration

Operational shock 30 g peak, half-sine, 11 ms pulse
(Tested in accordance with IEC-60068-2-27. Test profile developed in accordance with MIL-PRF-28800F.)

Random Vibration

Operating..... 5 to 500 Hz, 0.3 g_{rms}

Nonoperating..... 5 to 500 Hz, 2.4 g_{rms}
(Tested in accordance with IEC-60068-2-64. Nonoperating test profile exceeds the requirements of MIL-PRF-28800F, Class 3.)

Safety

The PXI-1050 is designed to meet the requirements of the following standards of safety for electrical equipment for measurement, control, and laboratory use:

- EN 61010-1, IEC 61010-1
- UL 61010-1
- CAN/CSA-C22.2 No. 61010.1



Note For UL and other safety certifications, refer to the product label, or visit ni.com/certification, search by model number or product line, and click the appropriate link in the Certification column.

Electromagnetic Compatibility

Emissions EN 55011 Class A at 10 m
FCC Part 15A above 1 GHz¹

Immunity EN 61326:1997 + A2:2001,
Table 1

EMC/EMI..... CE, C-Tick, and FCC Part 15
(Class A) Compliant

¹ DC input exempt from emissions requirements.



Note For EMC compliance, operate this device with shielded cabling. In addition, all covers and filler panels must be installed.

CE Compliance

This product meets the essential requirements of applicable European Directives, as amended for CE marking, as follows:

Low-Voltage Directive (safety).....73/23/EEC

Electromagnetic Compatibility
Directive (EMC)89/336/EEC



Note Refer to the Declaration of Conformity (DoC) for this product for any additional regulatory compliance information. To obtain the DoC for this product, visit ni.com/certification, search by model number or product line, and click the appropriate link in the Certification column.

Backplane

Size3U-sized; one system slot (with three system expansion slots) and seven peripheral slots.
Compliant with IEEE 1101.10 mechanical packaging.
PXI Specification Revision 2.1 compliant.
Accepts both PXI and CompactPCI (PICMG 2.0 R2.1) 3U modules.

Backplane bare-board materialUL 94 V-0 recognized (File No. E 116551)

Backplane connectorsConform to IEC 917 and IEC 1076-4-101, and are UL 94 V-0 rated

10 MHz System Reference Clock (PXI_CLK10)

Maximum clock skew between slots	250 ps
Built-in 10 MHz clock	
Accuracy	±25 ppm (guaranteed over the operating temperature range)
Maximum jitter	5 ps RMS in 10 Hz to 1 MHz range
External clock sources	
Connectors	Slot 2 J2 (pin D17; refer to Table B-4, <i>P2 (J2) Connector Pinout for the Star Trigger Slot</i>)
Input frequency	10 MHz ±100 ppm or better
Input amplitude	
Slot 2	5 V or 3.3 V, 10 MHz TTL signal
Maximum jitter introduced by backplane circuitry	1 ps RMS in 10 Hz to 1 MHz range

Mechanical

Overall dimensions	Refer to Figure A-1 through Figure A-3 for the physical dimensions of the PXI-1050 chassis
Weight	13 kg (29 lb)

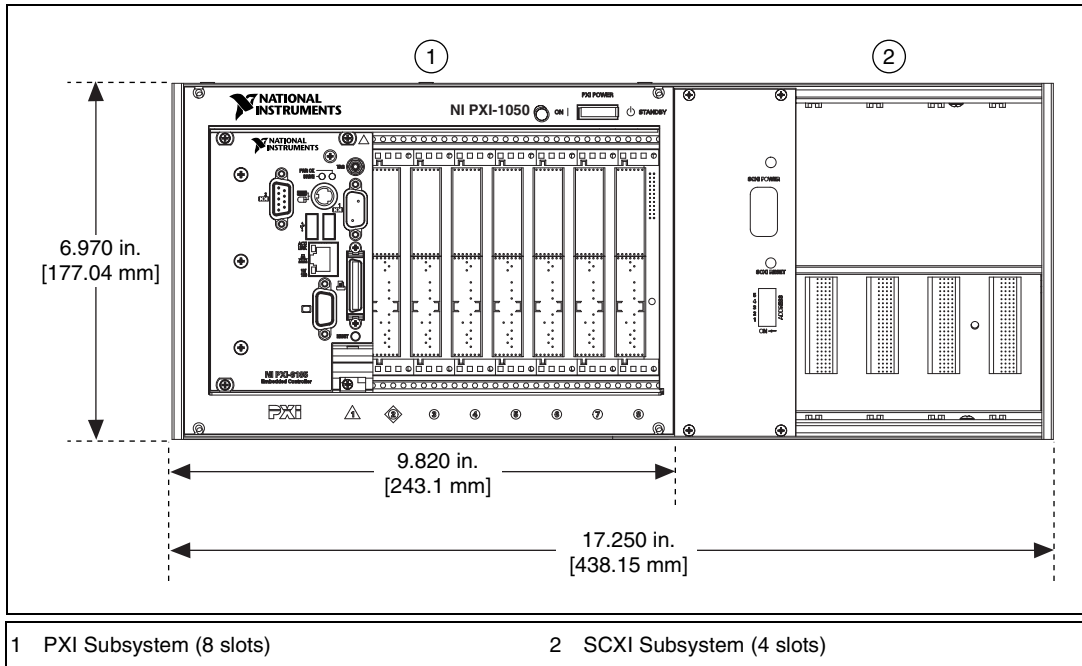

Figure A-1. PXI-1050 Dimensions (Front View Shown)

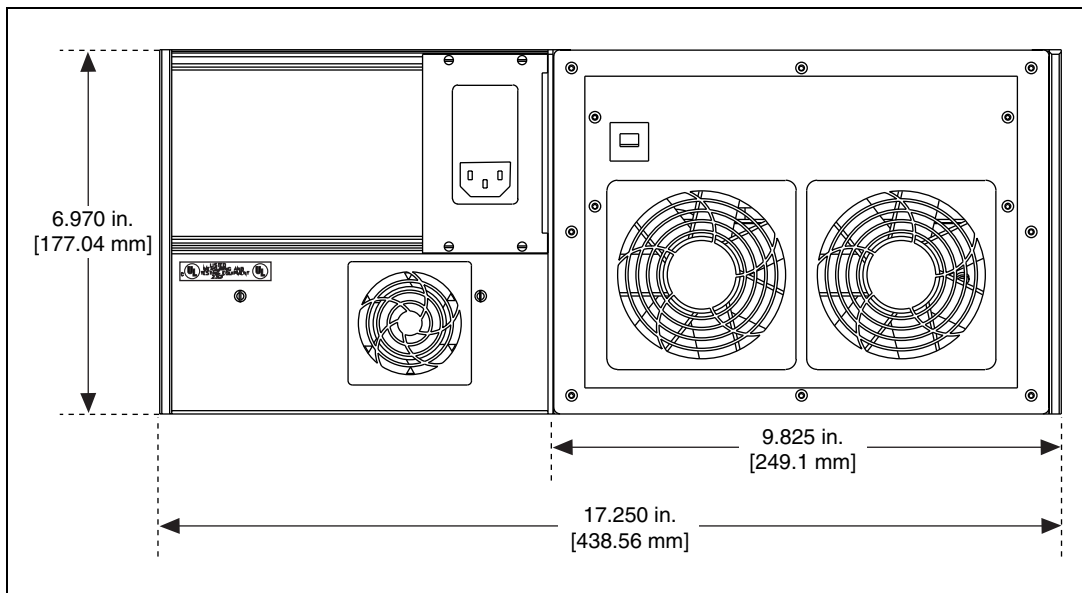

Figure A-2. PXI-1050 Dimensions (Rear View Shown)

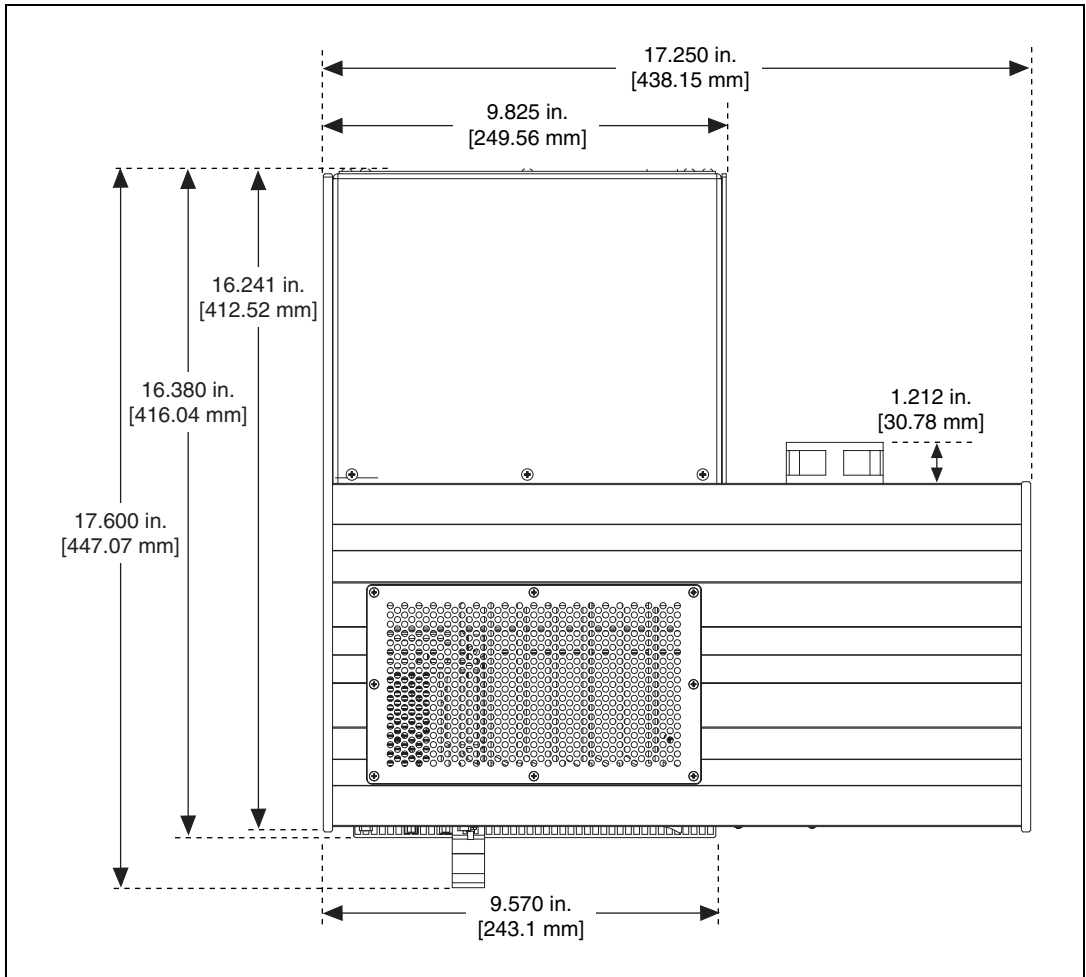

Figure A-3. PXI-1050 Dimensions (Top View Shown)

Pinouts

This appendix describes the P1 and P2 connector pinouts for the PXI-1050 backplane.

Table B-1 shows the P1 (J1) connector pinout for the System Controller slot.

Table B-2 shows the P2 (J2) connector pinout for the System Controller slot.

Table B-3 shows the P1 (J1) connector pinout for the star trigger slot.

Table B-4 shows the P2 (J2) connector pinout for the star trigger slot.

Table B-5 shows the P1 (J1) connector pinout for the peripheral slots.

Table B-6 shows the P2 (J2) connector pinout for the peripheral slots.



Note PXI signals are shown in bold.

For more detailed information, refer to the *PXI Hardware Specification, Revision 2.1*. Contact the PXI Systems Alliance for a copy of the specification or visit www.pxisa.org.

Table B-1. P1 (J1) Connector Pinout for the System Controller Slot

Pin	Z	A	B	C	D	E	F
25	GND	5V	REQ64#	ENUM#	3.3V	5V	GND
24	GND	AD[1]	5V	V(I/O)	AD[0]	ACK64#	GND
23	GND	3.3V	AD[4]	AD[3]	5V	AD[2]	GND
22	GND	AD[7]	GND	3.3V	AD[6]	AD[5]	GND
21	GND	3.3V	AD[9]	AD[8]	M66EN	C/BE[0]#	GND
20	GND	AD[12]	GND	V(I/O)	AD[11]	AD[10]	GND
19	GND	3.3V	AD[15]	AD[14]	GND	AD[13]	GND
18	GND	SERR#	GND	3.3V	PAR	C/BE[1]#	GND
17	GND	3.3V	IPMB_SCL	IPMB_SDA	GND	PERR#	GND
16	GND	DEVSEL#	GND	V(I/O)	STOP#	LOCK#	GND
15	GND	3.3V	FRAME#	IRDY#	GND	TRDY#	GND
12–14	Key Area						
11	GND	AD[18]	AD[17]	AD[16]	GND	C/BE[2]#	GND
10	GND	AD[21]	GND	3.3V	AD[20]	AD[19]	GND
9	GND	C/BE[3]#	GND	AD[23]	GND	AD[22]	GND
8	GND	AD[26]	GND	V(I/O)	AD[25]	AD[24]	GND
7	GND	AD[30]	AD[29]	AD[28]	GND	AD[27]	GND
6	GND	REQ0#	GND	3.3V	CLK0	AD[31]	GND
5	GND	BRSVP1A5	BRSVP1B5	RST#	GND	GNT0#	GND
4	GND	IPMB_PWR	HEALTHY	V(I/O)	INTP	INTS	GND
3	GND	INTA#	INTB#	INTC#	5V	INTD#	GND
2	GND	TCK	5V	TMS	TDO	TDI	GND
1	GND	5V	-12V	TRST#	+12V	5V	GND

Table B-2. P2 (J2) Connector Pinout for the System Controller Slot

Pin	Z	A	B	C	D	E	F
22	GND	GA4	GA3	GA2	GA1	GA0	GND
21	GND	CLK6	GND	RSV	RSV	RSV	GND
20	GND	CLK5	GND	RSV	GND	RSV	GND
19	GND	GND	GND	SMB_SDA	SMB_SCL	SMB_ALERT#	GND
18	GND	PXI_TRIG3	PXI_TRIG4	PXI_TRIG5	GND	PXI_TRIG6	GND
17	GND	PXI_TRIG2	GND	PRST#	REQ6#	GNT6#	GND
16	GND	PXI_TRIG1	PXI_TRIG0	DEG#	GND	PXI_TRIG7	GND
15	GND	PXI_BRSVA15	GND	FAL#	REQ5#	GNT5#	GND
14	GND	AD[35]	AD[34]	AD[33]	GND	AD[32]	GND
13	GND	AD[38]	GND	V(I/O)	AD[37]	AD[36]	GND
12	GND	AD[42]	AD[41]	AD[40]	GND	AD[39]	GND
11	GND	AD[45]	GND	V(I/O)	AD[44]	AD[43]	GND
10	GND	AD[49]	AD[48]	AD[47]	GND	AD[46]	GND
9	GND	AD[52]	GND	V(I/O)	AD[51]	AD[50]	GND
8	GND	AD[56]	AD[55]	AD[54]	GND	AD[53]	GND
7	GND	AD[59]	GND	V(I/O)	AD[58]	AD[57]	GND
6	GND	AD[63]	AD[62]	AD[61]	GND	AD[60]	GND
5	GND	C/BE[5]#	GND	V(I/O)	C/BE[4]#	PAR64	GND
4	GND	V(I/O)	PXI_BRSVB4	C/BE[7]#	GND	C/BE[6]#	GND
3	GND	CLK4	GND	GNT3#	REQ4#	GNT4#	GND
2	GND	CLK2	CLK3	SYSEN#	GNT2#	REQ3#	GND
1	GND	CLK1	GND	REQ1#	GNT1#	REQ2#	GND

Table B-3. P1 (J1) Connector Pinout for the Star Trigger Slot

Pin	Z	A	B	C	D	E	F
25	GND	5V	REQ64#	ENUM#	3.3V	5V	GND
24	GND	AD[1]	5V	V(I/O)	AD[0]	ACK64#	GND
23	GND	3.3V	AD[4]	AD[3]	5V	AD[2]	GND
22	GND	AD[7]	GND	3.3V	AD[6]	AD[5]	GND
21	GND	3.3V	AD[9]	AD[8]	M66EN	C/BE[0]#	GND
20	GND	AD[12]	GND	V(I/O)	AD[11]	AD[10]	GND
19	GND	3.3V	AD[15]	AD[14]	GND	AD[13]	GND
18	GND	SERR#	GND	3.3V	PAR	C/BE[1]#	GND
17	GND	3.3V	IPMB_SCL	IPMB_SDA	GND	PERR#	GND
16	GND	DEVSEL#	GND	V(I/O)	STOP#	LOCK#	GND
15	GND	3.3V	FRAME#	IRDY#	BD_SEL#	TRDY#	GND
12–14	Key Area						
11	GND	AD[18]	AD[17]	AD[16]	GND	C/BE[2]#	GND
10	GND	AD[21]	GND	3.3V	AD[20]	AD[19]	GND
9	GND	C/BE[3]#	IDSEL	AD[23]	GND	AD[22]	GND
8	GND	AD[26]	GND	V(I/O)	AD[25]	AD[24]	GND
7	GND	AD[30]	AD[29]	AD[28]	GND	AD[27]	GND
6	GND	REQ#	GND	3.3V	CLK	AD[31]	GND
5	GND	BRSVP1A5	BRSVP1B5	RST#	GND	GNT#	GND
4	GND	IPMB_PWR	HEALTHY	V(I/O)	INTP	INTS	GND
3	GND	INTA#	INTB#	INTC#	5V	INTD#	GND
2	GND	TCK	5V	TMS	TDO	TDI	GND
1	GND	5V	-12V	TRST#	+12V	5V	GND

Table B-4. P2 (J2) Connector Pinout for the Star Trigger Slot

Pin	Z	A	B	C	D	E	F
22	GND	GA4	GA3	GA2	GA1	GA0	GND
21	GND	PXI_LBR0	RSV	PXI_LBR1	PXI_LBR2	PXI_LBR3	GND
20	GND	PXI_LBR4	PXI_LBR5	PXI_STAR0	GND	PXI_STAR1	GND
19	GND	PXI_STAR2	RSV	PXI_STAR3	PXI_STAR4	PXI_STAR5	GND
18	GND	PXI_TRIG3	PXI_TRIG4	PXI_TRIG5	GND	PXI_TRIG6	GND
17	GND	PXI_TRIG2	GND	RSV	PXI_CLK10_IN	PXI_CLK10	GND
16	GND	PXI_TRIG1	PXI_TRIG0	RSV	GND	PXI_TRIG7	GND
15	GND	PXI_BRSVA15	GND	RSV	PXI_STAR6	PXI_LBR6	GND
14	GND	AD[35]	AD[34]	AD[33]	GND	AD[32]	GND
13	GND	AD[38]	GND	V(I/O)	AD[37]	AD[36]	GND
12	GND	AD[42]	AD[41]	AD[40]	GND	AD[39]	GND
11	GND	AD[45]	GND	V(I/O)	AD[44]	AD[43]	GND
10	GND	AD[49]	AD[48]	AD[47]	GND	AD[46]	GND
9	GND	AD[52]	GND	V(I/O)	AD[51]	AD[50]	GND
8	GND	AD[56]	AD[55]	AD[54]	GND	AD[53]	GND
7	GND	AD[59]	GND	V(I/O)	AD[58]	AD[57]	GND
6	GND	AD[63]	AD[62]	AD[61]	GND	AD[60]	GND
5	GND	C/BE[5]#	GND	V(I/O)	C/BE[4]#	PAR64	GND
4	GND	V(I/O)	PXI_BRSVB4	C/BE[7]#	GND	C/BE[6]#	GND
3	GND	PXI_LBR7	GND	PXI_LBR8	PXI_LBR9	PXI_LBR10	GND
2	GND	PXI_LBR11	PXI_LBR12	UNC	PXI_STAR7	PXI_STAR8	GND
1	GND	PXI_STAR9	GND	PXI_STAR10	PXI_STAR11	PXI_STAR12	GND

Table B-5. P1 (J1) Connector Pinout for the Generic Peripheral Slot

Pin	Z	A	B	C	D	E	F
25	GND	5V	REQ64#	ENUM#	3.3V	5V	GND
24	GND	AD[1]	5V	V(I/O)	AD[0]	ACK64#	GND
23	GND	3.3V	AD[4]	AD[3]	5V	AD[2]	GND
22	GND	AD[7]	GND	3.3V	AD[6]	AD[5]	GND
21	GND	3.3V	AD[9]	AD[8]	M66EN	C/BE[0]#	GND
20	GND	AD[12]	GND	V(I/O)	AD[11]	AD[10]	GND
19	GND	3.3V	AD[15]	AD[14]	GND	AD[13]	GND
18	GND	SERR#	GND	3.3V	PAR	C/BE[1]#	GND
17	GND	3.3V	IPMB_SCL	IPMB_SDA	GND	PERR#	GND
16	GND	DEVSEL#	GND	V(I/O)	STOP#	LOCK#	GND
15	GND	3.3V	FRAME#	IRDY#	BD_SEL#	TRDY#	GND
12–14	Key Area						
11	GND	AD[18]	AD[17]	AD[16]	GND	C/BE[2]#	GND
10	GND	AD[21]	GND	3.3V	AD[20]	AD[19]	GND
9	GND	C/BE[3]#	IDSEL	AD[23]	GND	AD[22]	GND
8	GND	AD[26]	GND	V(I/O)	AD[25]	AD[24]	GND
7	GND	AD[30]	AD[29]	AD[28]	GND	AD[27]	GND
6	GND	REQ#	GND	3.3V	CLK	AD[31]	GND
5	GND	BRSVP1A5	BRSVP1B5	RST#	GND	GNT#	GND
4	GND	IPMB_PWR	HEALTHY	V(I/O)	INTP	INTS	GND
3	GND	INTA#	INTB#	INTC#	5V	INTD#	GND
2	GND	TCK	5V	TMS	TDO	TDI	GND
1	GND	5V	-12V	TRST#	+12V	5V	GND

Table B-6. P2 (J2) Connector Pinout for the Generic Peripheral Slot

Pin	Z	A	B	C	D	E	F
22	GND	GA4	GA3	GA2	GA1	GA0	GND
21	GND	PXI_LBR0	RSV	PXI_LBR1	PXI_LBR2	PXI_LBR3	GND
20	GND	PXI_LBR4	PXI_LBR5	PXI_LBL0	GND	PXI_LBL1	GND
19	GND	PXI_LBL2	RSV	PXI_LBL3	PXI_LBL4	PXI_LBL5	GND
18	GND	PXI_TRIG3	PXI_TRIG4	PXI_TRIG5	GND	PXI_TRIG6	GND
17	GND	PXI_TRIG2	GND	RSV	PXI_STAR	PXI_CLK10	GND
16	GND	PXI_TRIG1	PXI_TRIG0	RSV	GND	PXI_TRIG7	GND
15	GND	PXI_BRSVA15	GND	RSV	PXI_LBL6	PXI_LBR6	GND
14	GND	AD[35]	AD[34]	AD[33]	GND	AD[32]	GND
13	GND	AD[38]	GND	V(I/O)	AD[37]	AD[36]	GND
12	GND	AD[42]	AD[41]	AD[40]	GND	AD[39]	GND
11	GND	AD[45]	GND	V(I/O)	AD[44]	AD[43]	GND
10	GND	AD[49]	AD[48]	AD[47]	GND	AD[46]	GND
9	GND	AD[52]	GND	V(I/O)	AD[51]	AD[50]	GND
8	GND	AD[56]	AD[55]	AD[54]	GND	AD[53]	GND
7	GND	AD[59]	GND	V(I/O)	AD[58]	AD[57]	GND
6	GND	AD[63]	AD[62]	AD[61]	GND	AD[60]	GND
5	GND	C/BE[5]#	GND	V(I/O)	C/BE[4]#	PAR64	GND
4	GND	V(I/O)	PXI_BRSVB4	C/BE[7]#	GND	C/BE[6]#	GND
3	GND	PXI_LBR7	GND	PXI_LBR8	PXI_LBR9	PXI_LBR10	GND
2	GND	PXI_LBR11	PXI_LBR12	UNC	PXI_LBL7	PXI_LBL8	GND
1	GND	PXI_LBL9	GND	PXI_LBL10	PXI_LBL11	PXI_LBL12	GND



Technical Support and Professional Services

Visit the following sections of the National Instruments Web site at ni.com for technical support and professional services:

- **Support**—Online technical support resources at ni.com/support include the following:
 - **Self-Help Resources**—For answers and solutions, visit the award-winning National Instruments Web site for software drivers and updates, a searchable KnowledgeBase, product manuals, step-by-step troubleshooting wizards, thousands of example programs, tutorials, application notes, instrument drivers, and so on.
 - **Free Technical Support**—All registered users receive free Basic Service, which includes access to hundreds of Application Engineers worldwide in the NI Developer Exchange at ni.com/exchange. National Instruments Application Engineers make sure every question receives an answer.

For information about other technical support options in your area, visit ni.com/services or contact your local office at ni.com/contact.

- **Training and Certification**—Visit ni.com/training for self-paced training, eLearning virtual classrooms, interactive CDs, and Certification program information. You also can register for instructor-led, hands-on courses at locations around the world.
- **System Integration**—If you have time constraints, limited in-house technical resources, or other project challenges, National Instruments Alliance Partner members can help. To learn more, call your local NI office or visit ni.com/alliance.
- **Declaration of Conformity (DoC)**—A DoC is our claim of compliance with the Council of the European Communities using the manufacturer's declaration of conformity. This system affords the user protection for electronic compatibility (EMC) and product safety. You can obtain the DoC for your product by visiting ni.com/certification.

- **Calibration Certificate**—If your product supports calibration, you can obtain the calibration certificate for your product at ni.com/calibration.

If you searched ni.com and could not find the answers you need, contact your local office or NI corporate headquarters. Phone numbers for our worldwide offices are listed at the front of this manual. You also can visit the Worldwide Offices section of ni.com/niglobal to access the branch office Web sites, which provide up-to-date contact information, support phone numbers, email addresses, and current events.

Glossary

Symbol	Prefix	Value
m	milli	10^{-3}
c	centi	10^{-2}
k	kilo	10^3
M	mega	10^6

Symbols

° Degrees

% Percent

A

A Amperes

AC Alternating current

ANSI American National Standards Institute

asynchronous

1. Software—an action or event that occurs at an unpredictable time with respect to the execution of a program
2. Hardware—a property of an event that occurs at an arbitrary time, without synchronization to a reference clock

B

backplane An assembly, typically a printed circuit board, with connectors and signal paths that bus the connector pins

bandwidth The range of frequencies present in a signal, or the range of frequencies to which a measuring device can respond

bus The group of connectors that interconnect individual circuitry in a computer. Typically, a bus is the expansion vehicle to which I/O or other devices are connected. Examples of PC buses are the ISA and PCI buses.

C

C Celsius

CSA Canadian Standards Association

D

daisy-chain A method of propagating signals along a bus, in which the devices are prioritized on the basis of their position on the bus

DC Direct current

E

EMC Electromagnetic Compatibility

F

FCC Federal Communications Commission

G

g
1. Grams
2. A measure of acceleration equal to 9.8 m/s²

GND Ground signal

g_{rms} A measure of random vibration; the root mean square of acceleration levels in a random vibration test profile

H

h	Hour
Hz	Hertz; cycles per second

I

I/O	Input/output
IEC	International Electrotechnical Commission; an organization that sets international electrical and electronics standards
IEEE	Institute of Electrical and Electronics Engineers
I_{MP}	Mainframe peak current
in.	Inches

L

lb	Pounds
local bus	A group of signals that connect two peripheral slots

M

m	Meters
MTBF	Mean time between failure

N

NEMA	National Electrical Manufacturers Association
------	---

O

over-current condition	When the load on a power supply draws more current than what the power supply is rated for
------------------------	--

P

PXI	PCI eXtensions for Instrumentation
PXI 10 MHz system clock signal	A 10 MHz clock reference provided by the PXI backplane to all peripheral modules
PXI backplane	The board in the PXI subsystem that connects the PXI modules
PXI_CLK10	The pin that provides the PXI 10 MHz system clock signal to a peripheral slot
PXI_CLK_10_IN	The pin that a star trigger module uses to supply the PXI 10 MHz system clock signal
PXI module	A PXI module that plugs into a PXI slot
PXI peripheral module	A PXI module that plugs into a PXI peripheral slot
PXI peripheral slot	Holds PXI peripheral modules
PXI subsystem	The PXI-1050 chassis section that uses PXI modules

R

RMS	Root mean square—A method used to measure electrical output in volts and watts
-----	--

S

s	Seconds
SCXI	SCXI stands for Signal Conditioning eXtensions for Instrumentation and is a National Instruments product line designed to perform front-end signal conditioning for National Instruments plug-in DAQ devices.
SCXI subsystem	The PXI-1050 chassis section that uses SCXI modules
slot	The slot in the chassis where a module is inserted
Slot 0	The power and control circuitry for the SCXI subsystem

Star Trigger slot	This slot is located at Slot 2 and has a dedicated trigger line between each peripheral slot. Use this slot for a module with Star Trigger functionality that can provide individual triggers to all other peripherals.
System Controller	A module configured for installation in Slot 0 of a VXIbus mainframe. This device is unique in the VXIbus system in that it performs the VMEbus system controller functions, including clock sourcing and arbitration for data transfers across the backplane. Installing such a device into any other slot can damage the device, the VXIbus backplane, or both.
system integrator	The party who connects pieces of hardware and software to create a complete system for the end user

T

trigger	Any event that causes or starts some form of data capture
TTL	Transistor-transistor logic

U

UL	Underwriter's Laboratories
----	----------------------------

V

V	Volts
VAC	Volts alternating current
voltage selection wheel	Configures the chassis for the AC line voltage

W

W	Watts
---	-------

Index

A

AC main circuit breaker, resetting, 3-3
address selection, SCXI subsystem, 2-1

B

backplane
 fuse replacement and check, 3-4
 PXI subsystem overview, 1-9
 SCXI subsystem overview, 1-9
 specification, A-6

C

cables
 optional, 1-5
 power cables (table), 1-2
calibration certificate (NI resources), C-2
circuit breaker
 PXI-1050 chassis rear view (figure), 1-8
 resetting, 3-3
cleaning procedures
 exterior cleaning, 3-2
 fan filters
 PXI subsystem, 3-2
 SCXI subsystem, 3-2
 interior cleaning, 3-1
 precautions, 3-2
clock, system reference, 1-12
CompactPCI
 interoperability with PXI subsystem
 backplane, 1-9
 module installation, 2-4
ComponentWorks software, 1-3
configuration
 See also installation
 line voltage-selection and fuse values, 2-2

 fuse part numbers (table), 2-3
 voltage selection and fuse ratings by
 region (table), 2-3
 SCXI subsystem address selection, 2-1
conventions used in the manual, *viii*

D

Declaration of Conformity (NI resources), C-1
diagnostic tools (NI resources), C-1
documentation
 conventions used in the manual, *viii*
 how to use manual set, *vii*
 NI resources, C-1
 related documentation, *ix*
drivers (NI resources), C-1

E

electromagnetic compatibility, A-5
equipment, optional, 1-5
examples (NI resources), C-1

F

fans and filters
 filter cleaning procedures
 PXI subsystem, 3-2
 SCXI subsystem, 3-2
 rear view of PXI-1050 (figure), 1-8
filler panel installation
 PXI subsystem, 2-6
 SCXI subsystem, 2-7
fuses
 line voltage-selection and fuse values, 2-2
 fuse part numbers (table), 2-3
 voltage selection and fuse ratings by
 region (table), 2-3

- PXI-1050 rear view
 - figure, 1-8
 - table, 1-8
- replacing, SCXI subsystem
 - backplane fuse replacement and check, 3-4
 - power entry module, 3-4

G

- getting started, 1-1

H

- help, technical support, C-1
- how to use manual set, *vii*

I

- initialization file for PXI chassis, 2-7
- installation
 - See also* configuration
 - mounting information, 2-1
 - PXI chassis initialization file, 2-7
 - PXI filler panel, 2-6
 - PXI module, 2-4
 - PXI-1050 chassis, 2-4
 - SCXI filler panel, 2-7
 - SCXI module, 2-6
 - unpacking PXI-1050 chassis, 1-2
- instrument drivers (NI resources), C-1

K

- key features of the PXI-1050 chassis, 1-5
- KnowledgeBase, C-1

L

- LabVIEW software, 1-3
- LabWindows/CVI software, 1-3
- line voltage selection and fuse values
 - fuse part numbers (table), 2-3
 - voltage selection and fuse ratings by region (table), 2-3
- local bus
 - description, 1-10
 - Star Trigger and local bus routing (figure), 1-11

M

- maintenance
 - cleaning, 3-1
 - fan filter cleaning
 - PXI subsystem, 3-2
 - SCXI subsystem, 3-2
 - preparation, 3-1
 - resetting AC main circuit breaker, 3-3
 - SCXI subsystem fuse replacement
 - backplane fuse replacement and check, 3-4
 - power entry module fuse, 3-4
 - service interval, 3-1
 - static discharge damage (caution), 3-1
 - troubleshooting the PXI-1050, 3-5
- mechanical specification, A-7
- mounting information, 2-1

N

- National Instruments
 - application software, 1-3
 - support and services, C-1
- NI-DAQ driver software
 - overview, 1-4
 - relationship with programming environment and hardware (figure), 1-4

O

optional equipment, 1-5

P

P1 (J1) connector

- peripheral slot (table), B-6
- star trigger slot (table), B-4
- system controller slot (table), B-2

P2 (J2) connector

- peripheral slot (table), B-7
- star trigger slot (table), B-5
- system controller slot (table), B-3

peripheral slots

- description, 1-10
- figure, 1-6
- P1 (J1) connector pinouts (table), B-6
- P2 (J2) connector pinouts (table), B-7

pinouts, B-1

P1 (J1) connector

- peripheral slot (table), B-6
- star trigger slot (table), B-4
- system controller slot (table), B-2

P2 (J2) connector

- peripheral slot (table), B-7
- star trigger slot (table), B-5
- system controller slot (table), B-3

power cables (table), 1-2

power failure, troubleshooting (table), 3-5

programming examples (NI resources), C-1

PXI subsystem

- cooling specification, A-3
- electrical characteristics, A-1
- filler panel installation, 2-6
- installation
 - injector/ejector handle position (figure), 2-6
 - procedure, 2-4
 - PXI or CompactPCI modules (figure), 2-5

interoperability with CompactPCI, 1-9

local bus, 1-10

peripheral slots, 1-10

SCXI connection, 1-11

Star Trigger and local bus routing (figure), 1-11

Star Trigger slot, 1-10

system reference clock, 1-12

trigger bus, 1-11

PXI-1050 chassis

front view items

- description (table), 1-6
- figure, 1-6

initialization file, 2-7

installation, 2-4

key features, 1-5

optional equipment, 1-5

overview, 1-1

PXI subsystem. *See* PXI subsystem

rear view items

- descriptions (table), 1-8
- figure, 1-8

requirements for getting started, 1-1

SCXI subsystem backplane overview, 1-9

software programming choices

- National Instruments application software, 1-3

NI-DAQ driver software, 1-4

register-level programming, 1-5

specifications. *See* specifications

unpacking, 1-2

R

reference clock, 1-12

register-level programming, 1-5

related documentation, *ix*

requirements for getting started, 1-1

resetting AC main circuit breaker, 3-3

S

safety specifications, A-5

SCXI subsystem

- address selection, 2-1
- backplane overview, 1-9
- connection for PXI peripheral module, 1-11
- electrical characteristics, A-3
- fan filter cleaning, 3-2
- filler panel installation
 - front filler panel, 2-7
 - rear filler panel, 2-7
- fuse replacement
 - backplane fuse replacement and check, 3-4
 - power entry module, 3-4
- indicators and switches on PXI-1050 chassis, 1-6
- installation, 2-6
- switch settings for address selection (figure), 2-2

software (NI resources), C-1

software programming choices

- National Instruments application software, 1-3
- NI-DAQ driver software, 1-4
- register-level programming, 1-5

specifications

- backplane, A-6
- electromagnetic compatibility, A-5
- mechanical, A-7
- safety, A-5

specifications, PXI-1050

- environmental, A-4

Star Trigger slot

- description, 1-10
- figure, 1-6
- P1 (J1) connector pinouts (table), B-4
- P2 (J2) connector pinouts (table), B-5

support, technical, C-1

System Controller slot

- description, 1-10

- figure, 1-6

system controller slot

- P1 (J1) connector pinouts (table), B-2

- P2 (J2) connector pinouts (table), B-3

system reference clock, 1-12

T

technical support, C-1

training and certification (NI resources), C-1

trigger bus overview, 1-11

troubleshooting

- NI resources, C-1

- PXI-1050 power failure (table), 3-5

U

unpacking PXI-1050 chassis, 1-2

V

VirtualBench software, 1-3

voltage selection wheel

- figure, 1-8

- fuse part numbers (table), 2-3

- setting line voltages and fuse values, 2-2

- voltage selection and fuse ratings by

- region (table), 2-3

W

Web resources, C-1