

# USER GUIDE AND SPECIFICATIONS

# USB-6008/6009

このドキュメントの日本語版については、[ni.com/jp/manuals](http://ni.com/jp/manuals)を参照してください。(For a Japanese language version, go to [ni.com/jp/manuals](http://ni.com/jp/manuals).)

This guide describes how to use the National Instruments USB-6008/6009 data acquisition (DAQ) devices and lists specifications.

## Introduction

---

The NI USB-6008/6009 provides connection to eight analog input (AI) channels, two analog output (AO) channels, 12 digital input/output (DIO) channels, and a 32-bit counter with a full-speed USB interface.



**Note** This manual revision updates naming conventions to reflect the conventions used in NI-DAQmx. Table 1 notes the correlation between the old and updated names.

**Table 1.** Digital Output Driver Type Naming Conventions

Hardware Functionality	NI-DAQmx Terminology
Open-drain	Open collector
Push-pull	Active drive

**Table 2.** Differences Between the USB-6008 and USB-6009

Feature	USB-6008	USB-6009
AI Resolution	12 bits differential, 11 bits single-ended	14 bits differential, 13 bits single-ended
Maximum AI Sample Rate, Single Channel*	10 kS/s	48 kS/s
Maximum AI Sample Rate, Multiple Channels (Aggregate)*	10 kS/s	48 kS/s
DIO Configuration	Open collector	Open collector or active drive
* System dependent.		

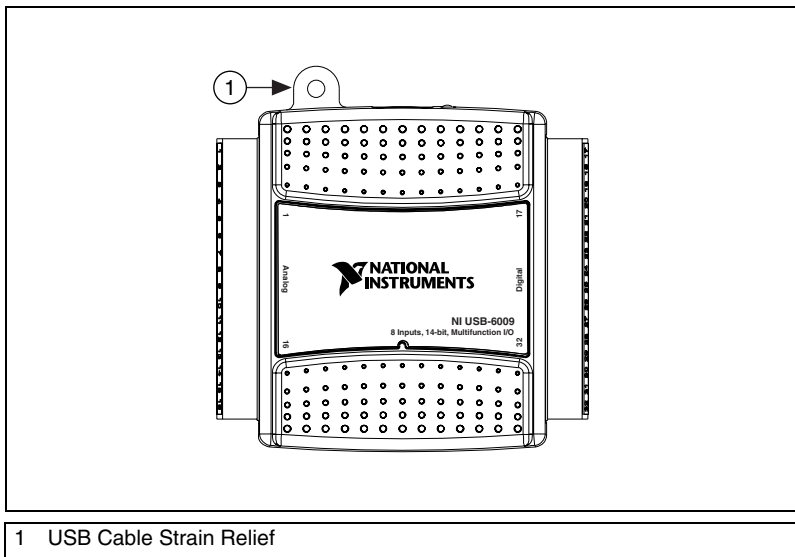

**Figure 1.** USB-6008/6009

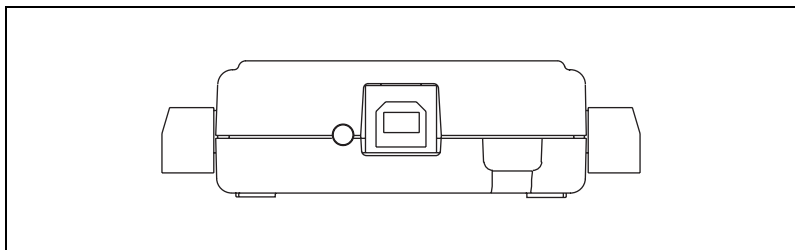

**Figure 2.** USB-6008/6009 Back View

# Safety Guidelines

---



**Caution** Operate the hardware only as described in these operating instructions.

The following section contains important safety information that you must follow when installing and using the USB-6008/6009.

Do not operate the USB-6008/6009 in a manner not specified in this document. Misuse of the device can result in a hazard. You can compromise the safety protection built into the device if the device is damaged in any way. If the device is damaged, contact National Instruments for repair.

Do not substitute parts or modify the device except as described in this document. Use the device only with the chassis, modules, accessories, and cables specified in the installation instructions. You must have all covers and filler panels installed during operation of the device.

Do not operate the device in an explosive atmosphere or where there may be flammable gases or fumes. If you must operate the device in such an environment, it must be in a suitably rated enclosure.

If you need to clean the device, use a dry cloth. Make sure that the device is completely dry and free from contaminants before returning it to service.

Operate the device only at or below Pollution Degree 2. Pollution is foreign matter in a solid, liquid, or gaseous state that can reduce dielectric strength or surface resistivity. The following is a description of pollution degrees:

- Pollution Degree 1 means no pollution or only dry, nonconductive pollution occurs. The pollution has no influence.
- Pollution Degree 2 means that only nonconductive pollution occurs in most cases. Occasionally, however, a temporary conductivity caused by condensation must be expected.
- Pollution Degree 3 means that conductive pollution occurs, or dry, nonconductive pollution occurs that becomes conductive due to condensation.

You must insulate signal connections for the maximum voltage for which the device is rated. Do not exceed the maximum ratings for the device. Do not install wiring while the device is live with electrical signals. Do not remove or add connector blocks when power is connected to the system. Avoid contact between your body and the connector block signal when hot swapping modules. Remove power from signal lines before connecting them to or disconnecting them from the device.

Operate the device at or below the Measurement Category I<sup>1</sup>. Measurement circuits are subjected to working voltages<sup>2</sup> and transient stresses (overvoltage) from the circuit to which they are connected during measurement or test. Measurement categories establish standard impulse withstand voltage levels that commonly occur in electrical distribution systems. The following is a description of measurement categories:

- Measurement Category I is for measurements performed on circuits not directly connected to the electrical distribution system referred to as MAINS<sup>3</sup> voltage. This category is for measurements of voltages from specially protected secondary circuits. Such voltage measurements include signal levels, special equipment, limited-energy parts of equipment, circuits powered by regulated low-voltage sources, and electronics.
- Measurement Category II is for measurements performed on circuits directly connected to the electrical distribution system. This category refers to local-level electrical distribution, such as that provided by a standard wall outlet (for example, 115 V for U.S. or 230 V for Europe). Examples of Measurement Category II are measurements performed on household appliances, portable tools, and similar E Series devices.
- Measurement Category III is for measurements performed in the building installation at the distribution level. This category refers to measurements on hard-wired equipment such as equipment in fixed installations, distribution boards, and circuit breakers. Other examples are wiring, including cables, bus-bars, junction boxes, switches, socket-outlets in the fixed installation, and stationary motors with permanent connections to fixed installations.
- Measurement Category IV is for measurements performed at the primary electrical supply installation (<1,000 V). Examples include electricity meters and measurements on primary overcurrent protection devices and on ripple control units.

---

<sup>1</sup> Measurement Category as defined in electrical safety standard IEC 61010-1. Measurement Category is also referred to as Installation Category.

<sup>2</sup> Working Voltage is the highest rms value of an AC or DC voltage that can occur across any particular insulation.

<sup>3</sup> MAINS is defined as a hazardous live electrical supply system that powers equipment. Suitably rated measuring circuits may be connected to the MAINS for measuring purposes.

# Software

---

Software support for the USB-6008/6009 for Windows 2000/XP is provided by NI-DAQmx.

The NI-DAQmx CD contains example programs that you can use to get started programming with the USB-6008/6009. Refer to the *NI-DAQmx for USB Devices Getting Started Guide*, that shipped with your device and is also accessible from **Start»All Programs»National Instruments»NI-DAQ** for more information.



**Note** For information about non-Windows operating system support, refer to [ni.com/info](http://ni.com/info) and enter `rddqld`.

## VI Logger

---

The NI-DAQmx CD includes VI Logger Lite which is an easy-to-use configuration-based tool specifically designed for data logging applications. The application is available at **Start»All Programs»National Instruments»VI Logger**.

# Hardware

The following block diagram shows key functional components of the USB-6008/6009.

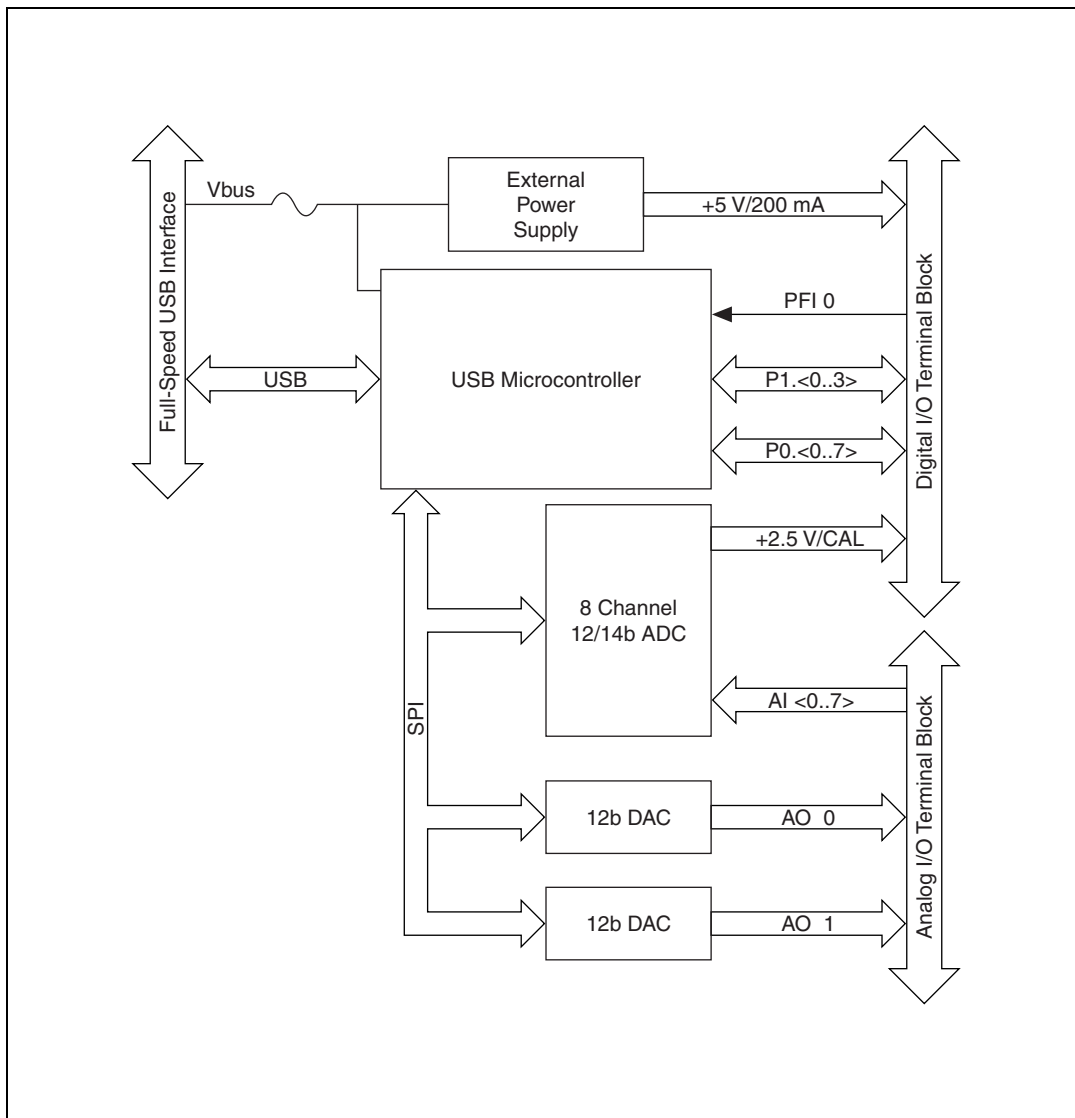

**Figure 3.** Device Block Diagram

# Setting Up Hardware

Complete the following steps to set up the hardware:

1. Install combicon screw terminal blocks by inserting them into the combicon jacks.



**Note** The USB-6008/6009 kit ships with signal labels. You can apply the signal labels to the screw terminal blocks for easy signal identification.

2. Refer to Table 3 and Figure 4 for signal label orientation and affix the provided signal labels to the screw terminal blocks. Until the signal labels are applied, you can insert the screw terminal blocks into either of the combicon jacks.

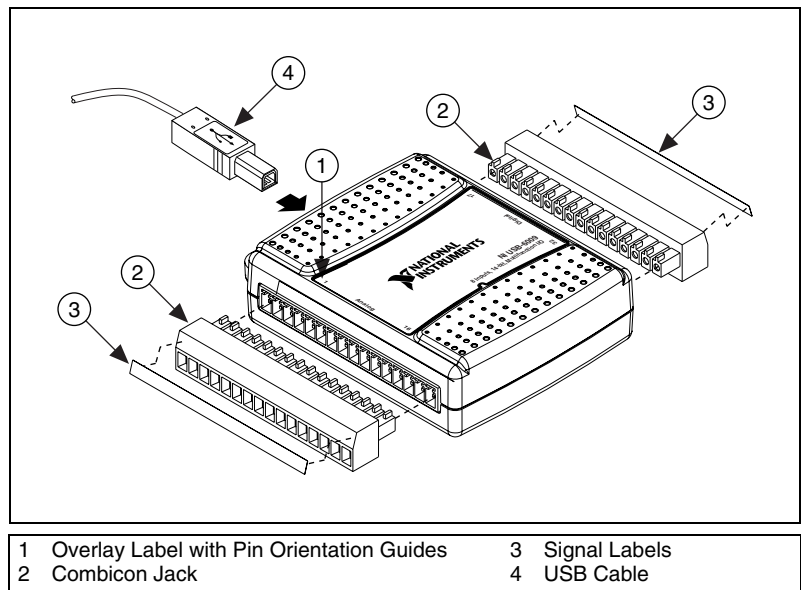

**Figure 4.** Signal Label Application Diagram



**Note** Once you label the screw terminal blocks, you must only insert them into the matching combicon jack, as indicated by the overlay label on the USB-6008/6009 device.

3. Connect the wiring to the appropriate screw terminals.

# I/O Connector

The USB-6008/6009 ships with one detachable screw terminal block for analog signals and one detachable screw terminal block for digital signals. These terminal blocks provide 16 connections that use 16 AWG to 28 AWG wire.

Table 3 lists the analog terminal assignments, and Table 4 lists the digital terminal assignments.

**Table 3.** Analog Terminal Assignments

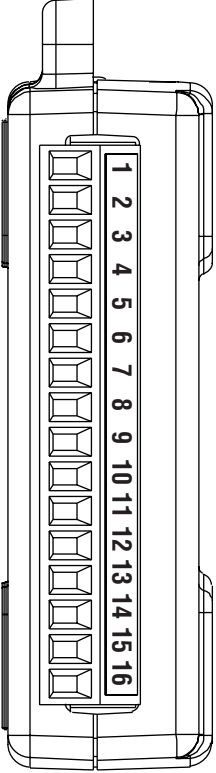
Module	Terminal	Signal, Single-Ended Mode	Signal, Differential Mode
	1	GND	GND
	2	AI 0	AI 0+
	3	AI 4	AI 0-
	4	GND	GND
	5	AI 1	AI 1+
	6	AI 5	AI 1-
	7	GND	GND
	8	AI 2	AI 2+
	9	AI 6	AI 2-
	10	GND	GND
	11	AI 3	AI 3+
	12	AI 7	AI 3-
	13	GND	GND
	14	AO 0	AO 0
	15	AO 1	AO 1
	16	GND	GND

**Table 4.** Digital Terminal Assignments

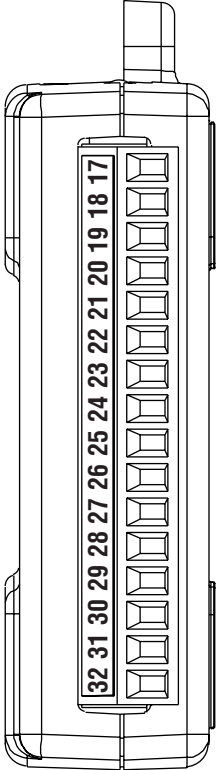
Module	Terminal	Signal
	17	P0.0
	18	P0.1
	19	P0.2
	20	P0.3
	21	P0.4
	22	P0.5
	23	P0.6
	24	P0.7
	25	P1.0
	26	P1.1
	27	P1.2
	28	P1.3
	29	PFI 0
	30	+2.5 V
	31	+5 V
	32	GND

# Signal Descriptions

Table 5 describes the signals available on the I/O connectors.

**Table 5.** Signal Descriptions

Signal Name	Reference	Direction	Description
GND	—	—	<b>Ground</b> —The reference point for the single-ended AI measurements, bias current return point for differential mode measurements, AO voltages, digital signals at the I/O connector, +5 VDC supply, and the +2.5 VDC reference.
AI <0..7>	Varies	Input	<b>Analog Input Channels 0 to 7</b> —For single-ended measurements, each signal is an analog input voltage channel. For differential measurements, AI 0 and AI 4 are the positive and negative inputs of differential analog input channel 0. The following signal pairs also form differential input channels: <AI 1, AI 5>, <AI 2, AI 6>, and <AI 3, AI 7>.
AO 0	GND	Output	<b>Analog Channel 0 Output</b> —Supplies the voltage output of AO channel 0.
AO 1	GND	Output	<b>Analog Channel 1 Output</b> —Supplies the voltage output of AO channel 1.
P1.<0..3> P0.<0..7>	GND	Input or Output	<b>Digital I/O Signals</b> —You can individually configure each signal as an input or output.
+2.5 V	GND	Output	<b>+2.5 V External Reference</b> —Provides a reference for wrap-back testing.
+5 V	GND	Output	<b>+5 V Power Source</b> —Provides +5 V power up to 200 mA.
PFI 0	GND	Input	<b>PFI 0</b> —This pin is configurable as either a digital trigger or an event counter input.

# Analog Input

You can connect analog input signals to the USB-6008/6009 through the I/O connector. Refer to Table 5 for more information about connecting analog input signals.

## Analog Input Circuitry

Figure 5 illustrates the analog input circuitry of the USB-6008/6009.

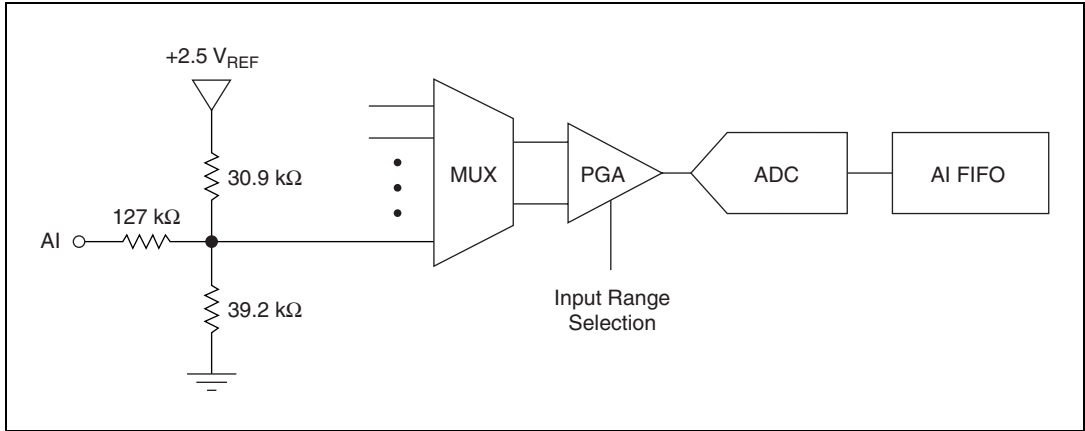

**Figure 5.** Analog Input Circuitry

## MUX

The USB 6008/6009 has one analog-to-digital converter (ADC). The multiplexer (MUX) routes one AI channel at a time to the PGA.

## PGA

The programmable-gain amplifier provides input gains of 1, 2, 4, 5, 8, 10, 16, or 20 when configured for differential measurements and gain of 1 when configured for single-ended measurements. The PGA gain is automatically calculated based on the voltage range selected in the measurement application.

## A/D Converter

The analog-to-digital converter (ADC) digitizes the AI signal by converting the analog voltage into a digital code.

## AI FIFO

The USB-6008/6009 can perform both single and multiple A/D conversions of a fixed or infinite number of samples. A first-in-first-out (FIFO) buffer holds data during AI acquisitions to ensure that no data is lost.

## Analog Input Modes

You can configure the AI channels on the USB-6008/6009 to take single-ended or differential measurements. Refer to Table 5 for more information about I/O connections for single-ended or differential measurements.

### Connecting Differential Voltage Signals

For differential signals, connect the positive lead of the signal to the AI+ terminal, and the negative lead to the AI- terminal.

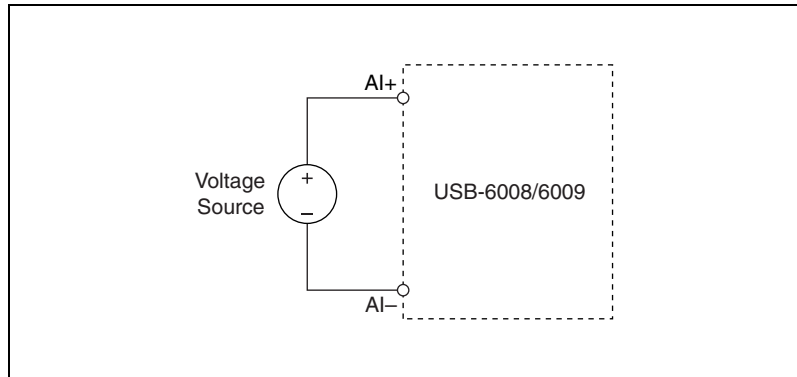

**Figure 6.** Connecting a Differential Voltage Signal

The differential input mode can measure  $\pm 20$  V signals in the  $\pm 20$  V range. However, the maximum voltage on any one pin is  $\pm 10$  V with respect to GND. For example, if AI 1 is +10 V and AI 5 is -10 V, then the measurement returned from the device is +20 V.

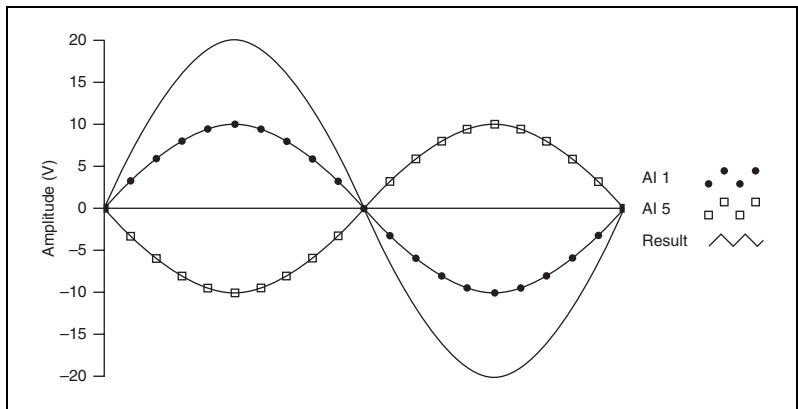

**Figure 7.** Example of a Differential 20 V Measurement

Connecting a signal greater than  $\pm 10$  V on either pin results in a clipped output.

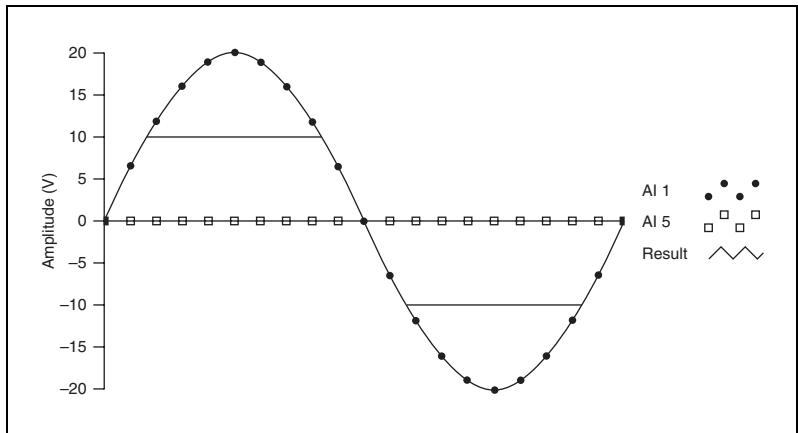

**Figure 8.** Exceeding +10 V on AI Returns Clipped Output

## Connecting Reference Single-Ended Voltage Signals

To connect reference single-ended voltage signals (RSE) to the USB-6008/6009, connect the positive voltage signal to the desired AI terminal, and the ground signal to a GND terminal.

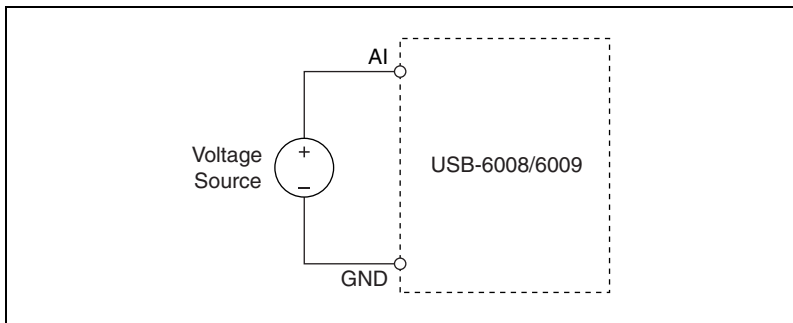

**Figure 9.** Connecting a Reference Single-Ended Voltage Signal

## Digital Trigger

When an AI task is defined, you can configure PFI 0 as a digital trigger input. When the digital trigger is enabled, the AI task waits for a rising edge on PFI 0 before starting the acquisition. To use ai/Start Trigger with a digital source, specify PFI 0 as the source and select rising edge.

## Analog Output

The USB-6008/6009 has two independent AO channels that can generate outputs from 0–5 V. All updates of AO lines are software-timed.

### Analog Output Circuitry

Figure 10 illustrates the analog output circuitry for the USB-6008/6009.

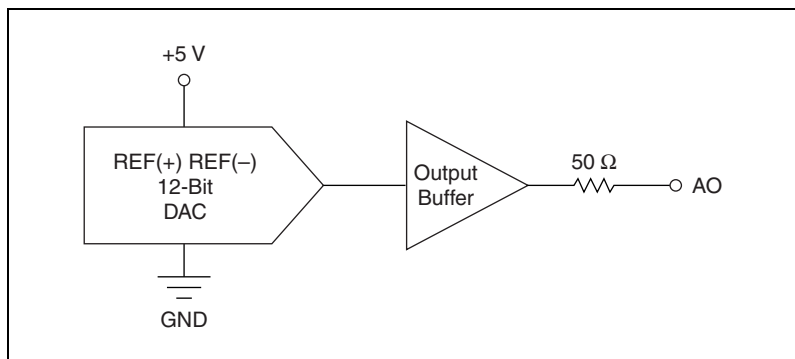

**Figure 10.** Analog Output Circuitry

### DACs

Digital-to-analog converters (DACs) convert digital codes to analog voltages.

## Connecting Analog Output Loads

To connect loads to the USB-6008/6009, connect the positive lead of the load to the AO terminal, and connect the ground of the load to a GND terminal.

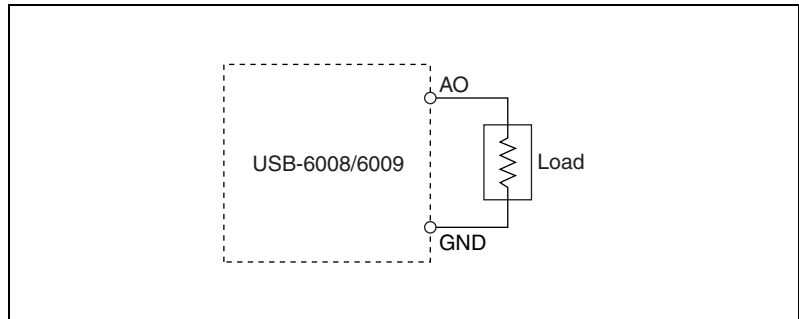

**Figure 11.** Connecting a Load

## Minimizing Glitches on the Output Signal

When you use a DAC to generate a waveform, you may observe glitches in the output signal. These glitches are normal; when a DAQ switches from one voltage to another, it produces glitches due to released charges. The largest glitches occur when the most significant bit of the DAC code changes. You can build a lowpass deglitching filter to remove some of these glitches, depending on the frequency and nature of the output signal. Refer to [ni.com/support](http://ni.com/support) for more information about minimizing glitches.

## Digital I/O

---

The USB-6008/6009 has 12 digital lines, P0.<0..7> and P1.<0..3>, which comprise the DIO port. GND is the ground-reference signal for the DIO port. You can individually program all lines as inputs or outputs.

### Digital I/O Circuitry

Figure 12 shows P0.<0..7> connected to example signals configured as digital inputs and digital outputs. You can configure P1.<0..3> similarly.

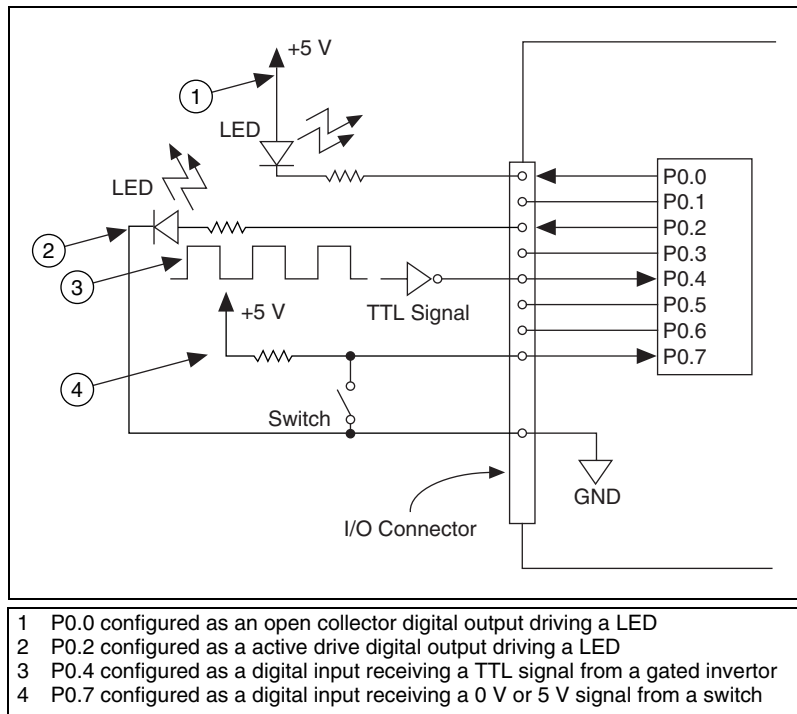

**Figure 12.** Example of Connecting a Load



**Caution** Exceeding the maximum input voltage ratings or maximum output ratings, which are listed in the *Specifications* section, can damage the DAQ device and the computer. National Instruments is not liable for any damage resulting from such signal connections.

## Source/Sink Information

The default configuration of the USB-6008/6009 DIO ports is open collector, allowing 5 V operation, with an onboard 4.7 k $\Omega$  pull-up resistor. An external, user-provided, pull-up resistor can be added to increase the source current drive up to a 8.5 mA limit per line as shown in Figure 13.

The USB-6009 ports can also be configured as active drive using the DAQmx API, allowing 3.3 V operation with a source/sink current limit of  $\pm 8.5$  mA. Refer to the *NI-DAQmx Help* for more information about how to set the DIO configuration.

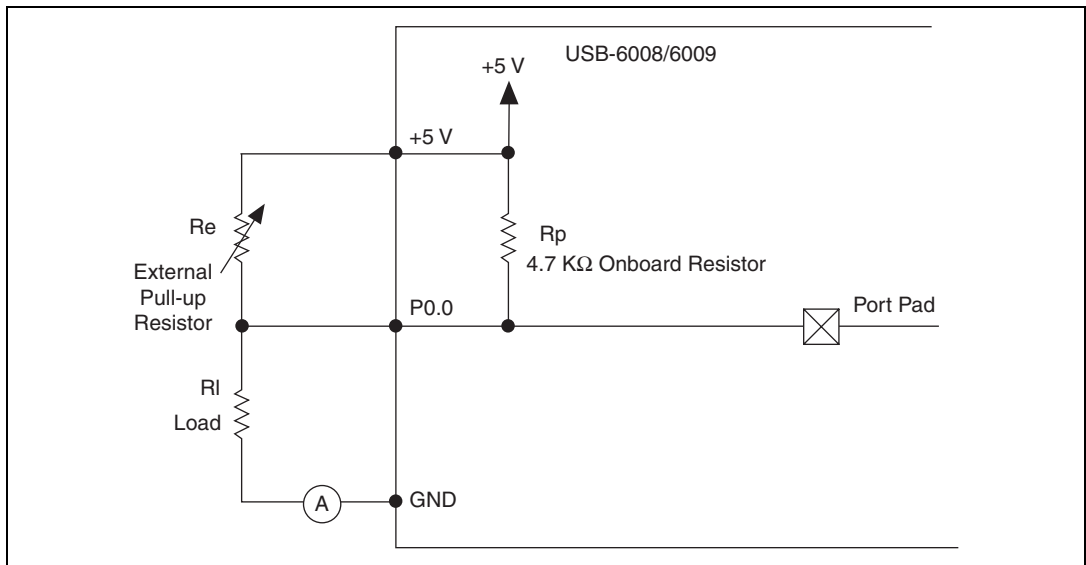

**Figure 13.** Example of Connecting External User-Provided Resistor

Complete the following steps to determine the value of the user-provided pull-up resistor:

1. Place an ammeter in series with the load.
2. Place a variable resistor between the digital output line and the +5 V.
3. Adjust the variable resistor until the ammeter current reads as the intended current. The intended current must be less than 8.5 mA.
4. Remove the ammeter and variable resistor from your circuit.
5. Measure the resistance of the variable resistor. The measured resistance is the ideal value of the pull-up resistor.
6. Select a static resistor value for your pull-up resistor that is greater than or equal to the ideal resistance.
7. Re-connect the load circuit and the pull-up resistor.

## I/O Protection

To protect the USB-6008/6009 against overvoltage, undervoltage, and overcurrent conditions, as well as ESD events, you should avoid these fault conditions by using the following guidelines:

- If you configure a DIO line as an output, do not connect it to any external signal source, ground signal, or power supply.
- If you configure a DIO line as an output, understand the current requirements of the load connected to these signals. Do not exceed the specified current output limits of the DAQ device.

National Instruments has several signal conditioning solutions for digital applications requiring high current drive.

- If you configure a DIO line as an input, do not drive the line with voltages outside of its normal operating range. The DIO lines have a smaller operating range than the AI signals.
- Treat the DAQ device as you would treat any static sensitive device. Always properly ground yourself and the equipment when handling the DAQ device or connecting to it.

## Power-On States

At system startup and reset, the hardware sets all DIO lines to high-impedance inputs. The DAQ device does not drive the signal high or low. Each line has a weak pull-up resistor connected to it.

## Static DIO

Each of the USB-6008/6009 DIO lines can be used as a static DI or DO line. You can use static DIO lines to monitor or control digital signals. All samples of static DI lines and updates of DO lines are software-timed.

## Event Counter

---

You can configure PFI 0 as a source for a gated inverter counter input edge count task. In this mode, falling-edge events are counted using a 32-bit counter. For more information about event timing requirements, refer to the [Specifications](#) section.

## Reference and Power Sources

---

The USB-6008/6009 creates an external reference and supplies a power source. All voltages are relative to COM unless otherwise noted.

### +2.5 External References

The USB-6008/6009 creates a high-purity reference voltage supply for the ADC using a multi-state regulator, amplifier, and filter circuit. The resulting +2.5 V reference voltage can be used as a signal for self test.

### +5 V Power Source

The USB-6008/6009 supplies a 5 V, 200 mA output. This source can be used to power external components.



**Note** While the device is in USB suspend, the output is disabled.

# Specifications

---

The following specifications are typical at 25 °C, unless otherwise noted.

## Analog Input

Converter type.....	Successive approximation
Analog inputs .....	8 single-ended, 4 differential, software selectable
Input resolution	
USB-6008 .....	12 bits differential, 11 bits single-ended
USB-6009 .....	14 bits differential, 13 bits single-ended
Max sampling rate <sup>1</sup>	
USB-6008 .....	10 kS/s
USB-6009 .....	48 kS/s
AI FIFO.....	512 bytes
Timing resolution.....	41.67 ns (24 MHz timebase)
Timing accuracy.....	100 ppm of actual sample rate
Input range	
Single-ended .....	±10 V
Differential.....	±20 V, ±10 V, ±5 V, ±4 V, ±2.5 V, ±2 V, ±1.25 V, ±1 V
Working voltage.....	±10 V
Input impedance.....	144 kΩ
Overtoltage protection.....	±35
Trigger source .....	Software or external digital trigger

---

<sup>1</sup> System dependent.

System noise<sup>1</sup>

Single-ended

±10 V range.....5 mVrms

Differential

±20 V range .....5 mVrms

±1 V range.....0.5 mVrms

Absolute accuracy at full scale, single ended

Range	Typical at 25 °C (mV)	Maximum over Temperature (mV)
±10	14.7	138

Absolute accuracy at full scale, differential<sup>1</sup>

Range	Typical at 25 °C (mV)	Maximum over Temperature (mV)
±20	14.7	138
±10	7.73	84.8
±5	4.28	58.4
±4	3.59	53.1
±2.5	2.56	45.1
±2	2.21	42.5
±1.25	1.70	38.9
±1	1.53	37.5

<sup>1</sup> Input voltages may not exceed the working voltage range.

## Analog Output

Converter type .....Successive approximation

Analog outputs.....2

Output resolution .....12 bits

Maximum update rate .....150 Hz, software-timed

Output range .....0 to +5 V

<sup>1</sup> System noise measured at maximum sample rate.

Output impedance .....	50 $\Omega$
Output current drive .....	5 mA
Power-on state.....	0 V
Slew rate.....	1 V/ $\mu$ s
Short circuit current .....	50 mA
Absolute accuracy (no load) .....	7 mV typical, 36.4 mV maximum at full scale

## Digital I/O

### Digital I/O

P0.<0..7>.....	8 lines
P1.<0..3>.....	4 lines
Direction control .....	Each channel individually programmable as input or output
Output driver type	
USB-6008 .....	Open collector (open-drain)
USB-6009 .....	Each channel individually programmable as active drive (push-pull) or open collector (open-drain)
Compatibility .....	TTL, LVTTTL, CMOS
Absolute maximum voltage range .....	-0.5 to 5.8 V with respect to GND
Pull-up resistor .....	4.7 k $\Omega$ to 5 V
Power-on state.....	Input

## Digital logic levels

Level	Min	Max	Units
Input low voltage	-0.3	0.8	V
Input high voltage	2.0	5.8	V
Input leakage current	—	50	$\mu$ A
Output low voltage (I = 8.5 mA)	—	0.8	V
Output high voltage			
Active drive (push-pull), I = -8.5 mA	2.0	3.5	V
Open collector (open-drain), I = -0.6 mA, nominal	2.0	5.0	V
Open collector (open-drain), I = -8.5 mA, with external pull-up resistor	2.0	—	V

## External Voltage

+5 V output (200 mA maximum) .....	+5 V typical, +4.85 V minimum
+2.5 V output (1 mA maximum) .....	+2.5 V typical
+2.5 V accuracy .....	0.25% max
Reference temperature drift .....	50 ppm/°C max

## Counter

Number of counters .....	1
Resolution .....	32 bits
Counter measurements .....	Edge counting (falling-edge)
Counter direction .....	Count up
Pull-up resistor .....	4.7 k $\Omega$ to 5 V
Maximum input frequency .....	5 MHz
Minimum high pulse width .....	100 ns
Minimum low pulse width .....	100 ns
Input high voltage .....	2.0 V
Input low voltage .....	0.8 V

## Bus Interface

USB specification .....	USB 2.0 full-speed
USB bus speed .....	12 Mb/s

## Power Requirements

### USB

4.10 to 5.25 VDC .....	80 mA typical, 500 mA max
USB suspend.....	300 $\mu$ A typical, 500 $\mu$ A max

## Physical Characteristics

If you need to clean the module, wipe it with a dry towel.

### Dimensions

Without connectors .....	6.35 cm $\times$ 8.51 cm $\times$ 2.31 cm (2.50 in. $\times$ 3.35 in. $\times$ 0.91 in.)
With connectors .....	8.18 cm $\times$ 8.51 cm $\times$ 2.31 cm (3.22 in. $\times$ 3.35 in. $\times$ 0.91 in.)

I/O connectors .....	USB series B receptacle, (2) 16 position terminal block plug headers
----------------------	--

### Weight

With connectors .....	84 g (3 oz)
Without connectors .....	54 g (1.9 oz)

Screw-terminal wiring.....	16 to 28 AWG
----------------------------	--------------

Torque for screw terminals .....	0.22–0.25 N $\cdot$ m (2.0–2.2 lb $\cdot$ in.)
----------------------------------	---

## Safety

### Standards

The USB-6008/6009 is designed to meet the requirements of the following standards of safety for electrical equipment for measurement, control, and laboratory use:

- IEC 61010-1, EN 61010-1
- UL 61010-1
- CAN/CSA-C22.2 No. 61010-1



**Note** For UL and other safety certifications, refer to the product label, or visit [ni.com/certification](http://ni.com/certification), search by model number or product line, and click the appropriate link in the Certification column.

## Voltages

Connect only voltages that are within these limits.

Channel-to-GND .....±30 V max,  
Measurement Category I

Measurement Category I is for measurements performed on circuits not directly connected to the electrical distribution system referred to as *MAINS* voltage. *MAINS* is a hazardous live electrical supply system that powers equipment. This category is for measurements of voltages from specially protected secondary circuits. Such voltage measurements include signal levels, special equipment, limited-energy parts of equipment, circuits powered by regulated low-voltage sources, and electronics.



**Caution** Do not use this module for connection to signals or for measurements within Measurement Categories II, III, or IV.

## Hazardous Locations

The USB-6008/6009 are not certified for use in hazardous locations.

## Environmental

The USB-6008/6009 device is intended for indoor use only.

Operating temperature  
(IEC 60068-2-1 and IEC 60068-2-2).....0 to 55 °C

Operating humidity  
(IEC 60068-2-56) .....5 to 95% RH, noncondensing

Maximum altitude.....2,000 m (at 25 °C ambient temperature)

Storage temperature  
(IEC 60068-2-1 and IEC 60068-2-2).....–40 to 85 °C

Storage humidity  
(IEC 60068-2-56) .....5 to 90% RH, noncondensing

Pollution Degree (IEC 60664).....2

## Electromagnetic Compatibility

Emissions .....	EN 55011 Class A at 10 m FCC Part 15A above 1 GHz
Immunity .....	Industrial levels per EN 61326:1997 + A2:2001, Table 1
EMC/EMI.....	CE, C-Tick, and FCC Part 15 (Class A) Compliant



**Note** The USB-6008/6009 may experience temporary variations in analog input readings when exposed to radiated and conducted RF noise. The device returns to normal operation after RF exposure is removed.

## CE Compliance

This product meets the essential requirements of applicable European Directives, as amended for CE marking, as follows:

Low-Voltage Directive (safety) ..... 73/23/EEC

Electromagnetic Compatibility  
Directive (EMC) ..... 89/336/EEC



**Note** Refer to the Declaration of Conformity (DoC) for this product for any additional regulatory compliance information. To obtain the DoC for this product, visit [ni.com/certification](http://ni.com/certification), search by model number or product line, and click the appropriate link in the Certification column.

## Where to Go for Support

---

The National Instruments Web site is your complete resource for technical support. At [ni.com/support](http://ni.com/support) you have access to everything from troubleshooting and application development self-help resources to email and phone assistance from NI Application Engineers.

A Declaration of Conformity (DoC) is our claim of compliance with the Council of the European Communities using the manufacturer's declaration of conformity. This system affords the user protection for electronic compatibility (EMC) and product safety. You can obtain the DoC for your product by visiting [ni.com/certification](http://ni.com/certification). If your product supports calibration, you can obtain the calibration certificate for your product at [ni.com/calibration](http://ni.com/calibration).

National Instruments corporate headquarters is located at 11500 North Mopac Expressway, Austin, Texas, 78759-3504. National Instruments also has offices located around the world to help address your support needs. For telephone support in the United States, create your service request at [ni.com/support](http://ni.com/support) and follow the calling instructions or dial 512 795 8248. For telephone support outside the United States, contact your local branch office:

Australia 1800 300 800, Austria 43 0 662 45 79 90 0,  
Belgium 32 0 2 757 00 20, Brazil 55 11 3262 3599,  
Canada 800 433 3488, China 86 21 6555 7838,  
Czech Republic 420 224 235 774, Denmark 45 45 76 26 00,  
Finland 385 0 9 725 725 11, France 33 0 1 48 14 24 24,  
Germany 49 0 89 741 31 30, India 91 80 41190000,  
Israel 972 0 3 6393737, Italy 39 02 413091, Japan 81 3 5472 2970,  
Korea 82 02 3451 3400, Lebanon 961 0 1 33 28 28,  
Malaysia 1800 887710, Mexico 01 800 010 0793,  
Netherlands 31 0 348 433 466, New Zealand 0800 553 322,  
Norway 47 0 66 90 76 60, Poland 48 22 3390150,  
Portugal 351 210 311 210, Russia 7 495 783 68 51,  
Singapore 1800 226 5886, Slovenia 386 3 425 42 00,  
South Africa 27 0 11 805 8197, Spain 34 91 640 0085,  
Sweden 46 0 8 587 895 00, Switzerland 41 56 200 51 51,  
Taiwan 886 02 2377 2222, Thailand 662 278 6777,  
United Kingdom 44 0 1635 523545

National Instruments, NI, ni.com, and LabVIEW are trademarks of National Instruments Corporation. Refer to the *Terms of Use* section on [ni.com/legal](http://ni.com/legal) for more information about National Instruments trademarks. Other product and company names mentioned herein are trademarks or trade names of their respective companies. For patents covering National Instruments products, refer to the appropriate location: **Help»Patents** in your software, the `patents.txt` file on your CD, or [ni.com/patents](http://ni.com/patents).