

CALIBRATION PROCEDURE

NI PXI-665x

This document describes how to write a calibration procedure for the 10 MHz oscillator frequency of the NI PXI-6653 and NI PXI-6652 timing and synchronization modules.

Contents

Conventions	1
Software	2
Documentation	2
Calibration Interval	3
Password	3
Test Equipment	3
Test Conditions	3
Calibration Procedure	4
Initial Setup	4
Verification	4
Connecting the Clock Source	4
Measuring the Frequency	6
Adjustment	10
Reverification	13
Where to Go for Support	14

Conventions

The following conventions apply to this document:

»

The » symbol leads you through nested menu items and dialog box options to a final action. The sequence **File»Page Setup»Options** directs you to pull down the **File** menu, select the **Page Setup** item, and select **Options** from the last dialog box.



This icon denotes a note, which alerts you to important information.



When symbol is marked on a product, it denotes a warning advising you to take precautions to avoid electrical shock.



When symbol is marked on a product, it denotes a component that may be hot. Touching this component may result in bodily injury.

bold

Bold text denotes items that you must select or click in the software, such as menu items and dialog box options. Bold text also denotes parameter names.

italic

Italic text denotes variables, emphasis, a cross-reference, or an introduction to a key concept. Italic text also denotes text that is a placeholder for a word or value that you must supply.

monospace

Text in this font denotes text or characters that you should enter from the keyboard, sections of code, programming examples, and syntax examples. This font is also used for the proper names of disk drives, paths, directories, programs, subprograms, subroutines, device names, functions, operations, variables, filenames, and extensions.

Software

This calibration procedure requires NI-Sync and NI-VISA. NI-Sync and NI-VISA support a number of application development environments (ADEs) and programming languages, including LabVIEW, LabWindows™/CVI™, and Microsoft Visual C++. When you install the drivers, you need to install support for only the ADE or programming language you are using. The illustrations in this document show the LabVIEW code for implementing calibration steps using NI-Sync and NI-VISA.

Documentation

You need the *NI-Sync User Manual* to calibrate the NI PXI-665x.

The *NI-Sync User Manual* contains detailed information about using the NI-Sync driver, including information about installing NI-Sync and creating applications that use the NI-Sync driver. These sources, along with this document, are your primary references for writing your calibration utility. You also can refer to the documentation for the programming language or application development environment you are using. For further information about the device you are calibrating, refer to the *NI PXI-665x User Manual*.

Calibration Interval

The measurement requirements of the application determine how often you should calibrate the device to ensure its accuracy. National Instruments recommends that you calibrate the NI PXI-6653 and NI PXI-6652 *yearly*. You may want to shorten this interval based on the application demands.

Password

The default password for password-protected operations is `NI`.

Test Equipment

Calibrating the NI PXI-665x requires the following equipment.

Equipment	Recommended Model	Requirements
10 MHz clock source	Symmetricom/Datum 8040	Accurate to within 0.75 parts-per-billion (ppb) for the NI PXI-6653, or 150 ppb for the NI PXI-6652.
BNC-SMB cable	—	—
SMB-SMB cable	—	—

Test Conditions

Follow these guidelines to optimize connections and test conditions during the calibration procedure:

- Install the NI PXI-665x in Slot 2 of the PXI chassis. The calibration procedure requires features of PXI that are accessible only in slot 2. Use of an NI PXI-1044 or NI PXI-1045 chassis is recommended to reduce error associated in variance in the 5 V chassis supply.
- Maintain a temperature of approximately 25 °C.
- Keep relative humidity below 80 percent.
- Use shielded copper wire for all cable connections to the device.
- Allow a warm up time of at least 15 minutes for the NI PXI-6652 and three hours for the NI PXI-6653 to ensure the measurement circuitry is at a stable operating temperature.
- Keep PXI chassis filters clean and fan speed set to High.

Calibration Procedure

The steps used in the calibration procedure are as follows:

1. Initial setup.
2. Verification.
3. Adjustment.
4. Reverification.

Initial Setup

Complete the following steps to set up the NI PXI-665x for calibration.

1. Make sure all components involved in the calibration procedure are powered off.
2. Install the NI PXI-665x board into slot 2 of your chassis.



Note The module *must* be installed in slot 2 of the chassis.

3. Power on the PXI chassis first, and then the external equipment.
4. Make sure that all the appropriate driver and application software is installed on the host computer.
5. Configure the hardware properly with Measurement & Automation Explorer (MAX). Refer to the *NI PXI-665x Installation Guide* for details about configuring the PXI equipment.

Verification

The following steps outline the procedure for measuring the 10 MHz oscillator frequency on the NI PXI-665x and determining whether the device requires adjustment to meet the published specifications.

Connecting the Clock Source

1. Connect the accurate 10 MHz source to the ClkIn connector on the NI PXI-665x.
2. Program the NI PXI-665x to route the ClkIn signal to PXI_Clk10In without using its 10 MHz PLL by completing steps a–d.



Note Use the data in the C function call reference as inputs to your LabVIEW VI where applicable.

- a. Call niSync Initialize VI to set up a handle for the device.

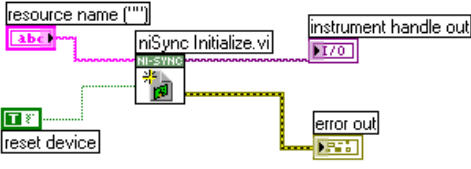
LabVIEW Block Diagram	NI-SYNC C Function Call
 <p>The diagram shows the 'niSync Initialize.vi' block. It has a 'resource name' input (string) with the value 'abc', an 'instrument handle out' output, and an 'error out' output. A 'reset device' control is connected to the 'niSync' block.</p>	<p>Call <code>niSync_init</code> with the following parameters:</p> <p>resourceName: Dev1 idQuery: NULL resetDevice: VI_TRUE vi: *SessionHandle</p>

- b. Set a writable NI-Sync property node to pass FALSE to the Use PLL? attribute.

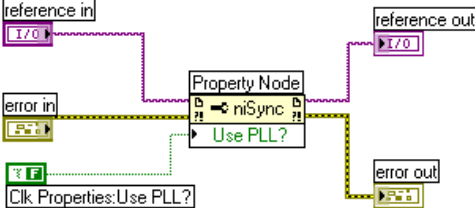
LabVIEW Block Diagram	NI-SYNC C Function Call
 <p>The diagram shows a 'Property Node' block. It has a 'reference in' input, an 'error in' input, and a 'reference out' output. The 'niSync' property is selected, and the 'Use PLL?' attribute is set to FALSE. A 'Clk Properties: Use PLL?' control is connected to the 'Use PLL?' attribute.</p>	<p>Call <code>niSync_SetAttributeViBoolean</code> with the following parameters:</p> <p>vi: "<SessionHandle>" terminalName: "" attributeID: NISYNC_ATTR_CLKIN_USE_PLL attributeValue: VI_FALSE</p>

- c. Call niSync Connect Clock Terminals VI to connect ClkIn to PXI_Clk10_In.

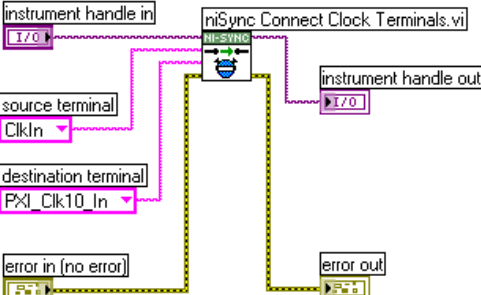
LabVIEW Block Diagram	NI-SYNC C Function Call
 <p>The diagram shows the 'niSync Connect Clock Terminals.vi' block. It has an 'instrument handle in' input, a 'source terminal' input (ClkIn), a 'destination terminal' input (PXI_Clk10_In), an 'instrument handle out' output, and an 'error in (no error)' input. The 'niSync' block is connected to the 'instrument handle in' and 'instrument handle out'.</p>	<p>Call <code>niSync_ConnectClkTerminals</code> with the following parameters:</p> <p>vi: "<SessionHandle>" sourceTerminal: NISYNC_VAL_CLKIN destinationTerminal: NISYNC_VAL_CLK10</p>

- d. Call niSync Close VI to close the handle.

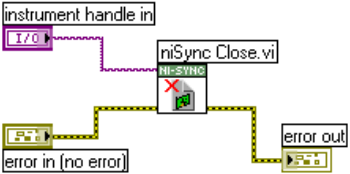
LabVIEW Block Diagram	NI-SYNC C Function Call
 <p>The diagram shows a LabVIEW block diagram for the niSync Close VI. It features an 'instrument handle in' terminal (I/O) connected to the 'niSync' input of the 'niSync Close.vi' block. An 'error in (no error)' terminal (E) is connected to the 'Error In' input of the block. The 'error out' terminal (E) is connected to the 'Error Out' output of the block.</p>	<p>Call <code>niSync_close</code> with the following parameter:</p> <p>vi: "<SessionHandle>"</p>

Measuring the Frequency

Complete the following procedure to measure the frequency of the onboard clock source.

1. Connect the **ClkOut** terminal to the PFI 0 terminal by using an SMB-to-SMB cable.
2. Complete steps a–d to program the board to connect the onboard oscillator to ClkOut. Be sure to use the high-gain setting for clock out.
 - a. Call niSync Initialize VI to set up a handle for the device.

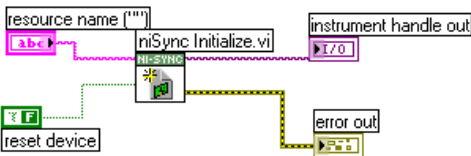
LabVIEW Block Diagram	NI-SYNC C Function Call
 <p>The diagram shows a LabVIEW block diagram for the niSync Initialize VI. It features a 'resource name' terminal (I/O) with the value 'abc' connected to the 'Resource Name' input of the 'niSync Initialize.vi' block. A 'reset device' terminal (E) is connected to the 'Reset Device' input of the block. The 'instrument handle out' terminal (I/O) is connected to the 'Instrument Handle Out' output of the block. An 'error out' terminal (E) is connected to the 'Error Out' output of the block.</p>	<p>Call <code>niSync_init</code> with the following parameters:</p> <p>resourceName: Dev1 idQuery: NULL (ignored) resetDevice: VI_FALSE vi: *SessionHandle</p>

- b. Set a writable NI-Sync property node to pass TRUE to the **ClkOut Gain Enable** attribute.

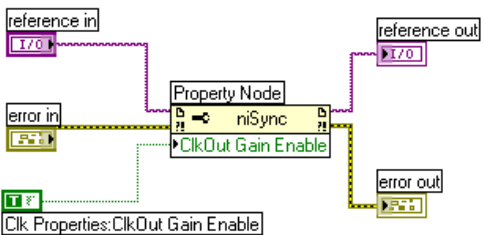
LabVIEW Block Diagram	NI-SYNC C Function Call
 <p>The diagram shows a LabVIEW block diagram for the niSync SetAttributeViBoolean VI. It features a 'reference in' terminal (I/O) connected to the 'Reference In' input of the 'niSync' block. A 'Property Node' block is connected to the 'niSync' block, with its 'ClkOut Gain Enable' property set to TRUE. An 'error in' terminal (E) is connected to the 'Error In' input of the block. The 'reference out' terminal (I/O) is connected to the 'Reference Out' output of the block. An 'error out' terminal (E) is connected to the 'Error Out' output of the block. A 'Clk Properties: ClkOut Gain Enable' terminal (E) is connected to the 'ClkOut Gain Enable' input of the block.</p>	<p>Call <code>niSync_SetAttributeViBoolean</code> with the following parameters:</p> <p>vi: "<SessionHandle>" terminalName: "" attributeID: <code>NISYNC_ATTR_CLKOUT_GAIN_ENABLE</code> attributeValue: <code>VI_TRUE</code></p>

- c. Call niSync Connect Clock Terminals VI to connect the oscillator to ClkOut.

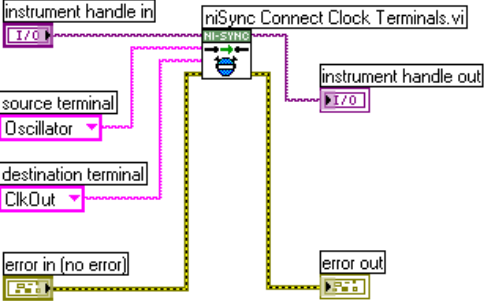
LabVIEW Block Diagram	NI-SYNC C Function Call
	<p>Call niSync_ConnectClkTerminals with the following parameters:</p> <p>vi: "<SessionHandle>"</p> <p>sourceTerminal: NISYNC_VAL_OSCILLATOR</p> <p>destinationTerminal: NISYNC_VAL_CLKOUT</p>

- d. Call niSync Close VI to close the session handle.

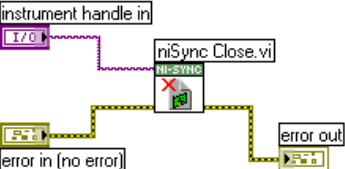
LabVIEW Block Diagram	NI-SYNC C Function Call
	<p>Call niSync_close with the following parameter:</p> <p>vi: "<SessionHandle>"</p>

3. Complete steps a–c to measure the oscillator frequency through PFI 0. To obtain an accurate measurement for calibration, the measurement duration must be made sufficiently long. Refer to Table 1 for the measurement duration to use.

Table 1. Measurement Duration

Device	Measure Accuracy	Required Measurement Duration
NI PXI-6652	200 ppb	0.5 seconds
NI PXI-6653	1 ppb	100 seconds

- a. Call niSync Initialize VI to set up a handle for the device.

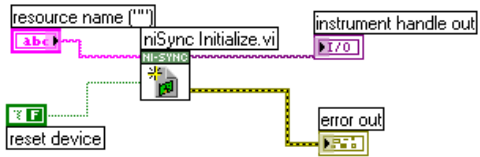
LabVIEW Block Diagram	NI-SYNC C Function Call
 <p>The diagram shows the 'niSync Initialize.vi' block. It has a 'resource name' input (string) and an 'instrument handle out' output (I/O). It also has an 'error in' and 'error out' terminal. A 'reset device' control is connected to the 'niSync Initialize.vi' block.</p>	<p>Call <code>niSync_init</code> with the following parameters:</p> <p>resourceName: Dev1 idQuery: NULL resetDevice: VI_FALSE vi: *SessionHandle</p>

- b. Call niSync Measure Frequency VI to measure the frequency of the oscillator.

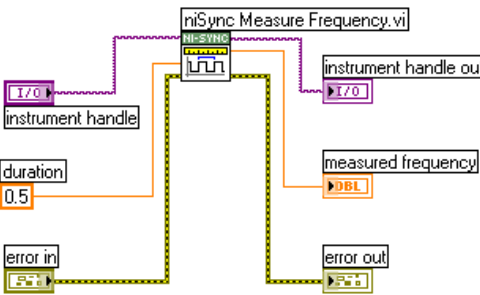
LabVIEW Block Diagram	NI-SYNC C Function Call
 <p>The diagram shows the 'niSync Measure Frequency.vi' block. It has an 'instrument handle' input (I/O), a 'duration' input (0.5), and an 'error in' terminal. It has an 'instrument handle out' (I/O), a 'measured frequency' output (DBL), and an 'error out' terminal.</p>	<p>Call <code>niSync_MeasureFrequency</code> with the following parameters:</p> <p>vi: "<SessionHandle>" sourceTerminal: NISYNC_VAL_OSCILLATOR duration: 0.5 or 100 actualDuration: *actualDuration measuredFrequency: *measuredFrequency error: *error</p>

- c. Call niSync Close VI to close the session handle.

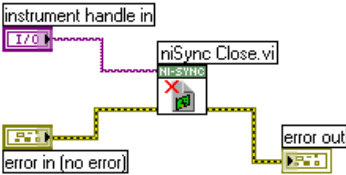
LabVIEW Block Diagram	NI-SYNC C Function Call
 <p>The diagram shows the 'niSync Close.vi' block. It has an 'instrument handle in' input (I/O) and an 'error in (no error)' terminal. It has an 'error out' terminal.</p>	<p>Call <code>niSync_close</code> with the following parameter:</p> <p>vi: "<SessionHandle>"</p>

4. Compare the measured frequency to the device specifications.

To determine if the device under test meets its specifications, you must compare the measured frequency obtained in step 3 of *Measuring the Frequency* with the specified accuracy. Table 2 shows the frequency range that is acceptable according to the published specifications for the NI PXI-665x.

Table 2. One Year Test Limits

Device	Specified Accuracy + Aging	Acceptable Frequency Range—As Found	
		Low Limit	High Limit
NI PXI-6652 (TCXO)	± 3.5 ppm	9,999,965 Hz	10,000,035 Hz
NI PXI-6653 (OCXO)	± 57.6 ppb	9,999,999.424 Hz	10,000,000.576 Hz

Table 3. 24 Hour Test Limits

Device	Specified Initial Accuracy	Acceptable Frequency Range—As Left	
		Low Limit	High Limit
NI PXI-6652 (TCXO)	± 2.5 ppm	9,999,975 Hz	10,000,025 Hz
NI PXI-6653 (OCXO)	± 6.1 ppb	9,999,999.939 Hz	10,000,000.061 Hz

If the measured value is within the low-limit and high-limit range listed under the *Acceptable Frequency Range—As Left* in Table 3, the board is meeting published specifications for the 24 hour period following a calibration.

Table 4. Calibration Target Frequency Ranges

Device	Calibration Measurement Accuracy	Calibration Measurement Target Frequency Range	
		Low Limit	High Limit
NI PXI-6652 (TCXO)	200 ppb	9,999,998 Hz	10,000,002 Hz
NI PXI-6653 (OCXO)	1 ppb	9,999,999.99 Hz	10,000,000.01 Hz

If the measured value is within the low-limit and high-limit range listed under the *Calibration Measurement Target Frequency Range* in Table 4, the board is considered to be calibrated and no adjustment is needed.

Adjustment

If the accuracy of the 10 MHz oscillator is outside the specified range for the product, the device is out of calibration. A programmable voltage controls the oscillator frequency. By varying this voltage and precisely measuring the frequency, you can find a voltage that gives a frequency as close as possible to 10 MHz.

1. Complete steps a–c to set the oscillator control voltage. The range of acceptable voltage values is 0.0 V to 4.095 V with frequency increasing as voltage increases. Use a control voltage of 2.0475 V, which is in the middle of the valid range, as a starting point.
 - a. Call niSync Initialize VI to set up a handle for the device.

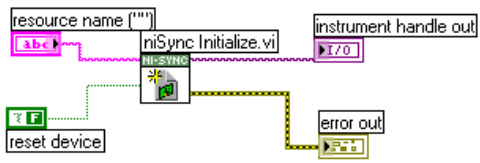
LabVIEW Block Diagram	NI-SYNC C Function Call
 <p>The diagram shows a LabVIEW block diagram for the niSync Initialize VI. It features a 'resource name' input control with the value 'abc', a 'reset device' control, and an 'error out' indicator. The niSync Initialize VI block is connected to an 'instrument handle out' control and the 'error out' indicator.</p>	<p>Call niSync_init with the following parameters:</p> <p>resourceName: Dev1 idQuery: NULL resetDevice: VI_FALSE vi: *SessionHandle</p>

- b. Set a writable NI-Sync property node to pass the constant **2.0475** to the **Oscillator Voltage** attribute.

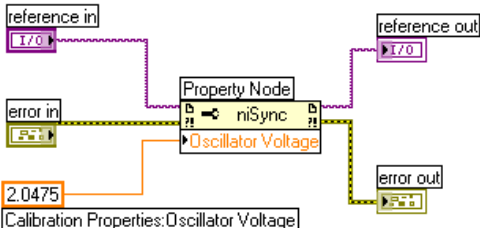
LabVIEW Block Diagram	NI-SYNC C Function Call
 <p>The diagram shows a LabVIEW block diagram for the niSync SetAttributeViBoolean function. It includes a 'reference in' control with value 'I70', an 'error in' indicator, a 'Property Node' block, an 'niSync' block, an 'Oscillator Voltage' attribute control, a 'Calibration Properties: Oscillator Voltage' control with value '2.0475', and an 'error out' indicator. The 'reference in' control is connected to the 'reference out' control. The 'niSync' block is connected to the 'error out' indicator.</p>	<p>Call niSync_SetAttributeViBoolean with the following parameters:</p> <p>vi: "<SessionHandle>" terminalName: "" attributeID: NISYNC_ATTR_OSCILLATOR_VOLTAGE attributeValue: 2.0475</p>

c. Call niSync Close VI to close the session handle.

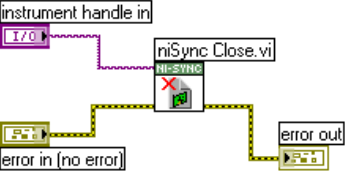
LabVIEW Block Diagram	NI-SYNC C Function Call
 <p>The diagram shows a LabVIEW block diagram for the niSync Close VI. It features an 'instrument handle in' terminal connected to the 'niSync Close.vi' block. An 'error in (no error)' terminal is also connected to the block. The output of the block is an 'error out' terminal.</p>	<p>Call <code>niSync_close</code> with the following parameter:</p> <p>vi: "<SessionHandle>"</p>

Proceed with the following steps to find the correct oscillator control voltage.

2. After setting the control voltage, measure the frequency again with the NI-Sync Measure Frequency VI to measure PFI 0, as shown in step 3 of the [Measuring the Frequency](#) section. To obtain an accurate measurement for calibration, the measurement duration must be made sufficiently long. Refer to Table 1, [Measurement Duration](#), for the measurement duration to use.

Complete steps a–c to measure PFI 0.

- a. Call niSync Initialize VI to set up a handle for the device.

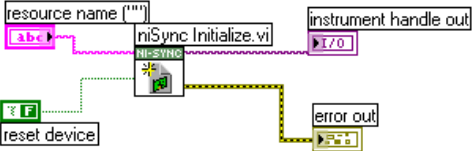
LabVIEW Block Diagram	NI-SYNC C Function Call
 <p>The diagram shows a LabVIEW block diagram for the niSync Initialize VI. It features a 'resource name ("")' terminal connected to the 'niSync Initialize.vi' block. A 'reset device' terminal is also connected to the block. The output of the block is an 'instrument handle out' terminal. An 'error out' terminal is also present.</p>	<p>Call <code>niSync_init</code> with the following parameters:</p> <p>resourceName: Dev1 idQuery: NULL resetDevice: VI_FALSE vi: *SessionHandle</p>

- b. Call niSync Measure Frequency VI to measure the frequency of the oscillator.

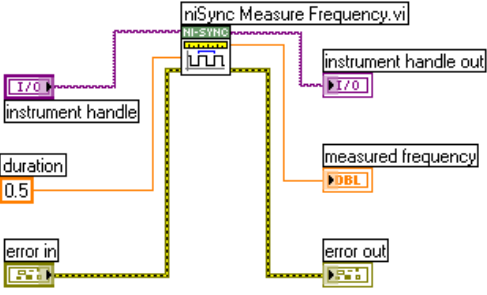
LabVIEW Block Diagram	NI-SYNC C Function Call
	<p>Call niSync_MeasureFrequency with the following parameters:</p> <p>vi: "<SessionHandle>"</p> <p>sourceTerminal: NISYNC_VAL_OSCILLATOR</p> <p>duration: 0.5 or 100</p> <p>actualDuration: *actualDuration</p> <p>measuredFrequency: *measuredFrequency</p> <p>error: *error</p>

- c. Call niSync Close VI to close the session handle.

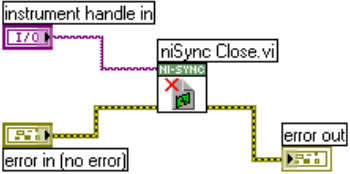
LabVIEW Block Diagram	NI-SYNC C Function Call
	<p>Call niSync_close with the following parameter:</p> <p>vi: "<SessionHandle>"</p>

3. Compare the measured frequency to the device specifications.
4. If the measured frequency is still outside of the specified limit, repeat steps 1–3 of the *Adjustment* section until the measured value falls within the acceptable frequency range for your module, as shown in Table 4, *Calibration Target Frequency Ranges*.
5. Commit the calibration values to the Calibration EEPROM using the following procedure.
 - a. Call niSync Initialize External Calibration VI to initialize the process.

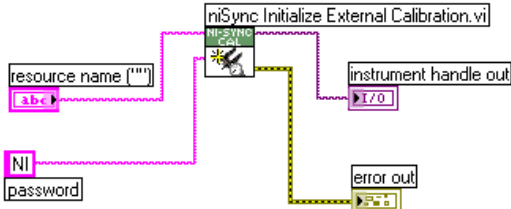

Note NI is the default user password. If you have changed the calibration password, use your user-selected calibration password in place of NI.

LabVIEW Block Diagram	NI-SYNC C Function Call
	<p>Call niSync_InitExtCal with the following parameters:</p> <p>resourceName: "<MAX ID>" password: NI calibrationInstrumentHandle: *SessionHandle</p>

- b. Call niSync Adjust Oscillator Voltage VI to adjust the voltage of the oscillator.

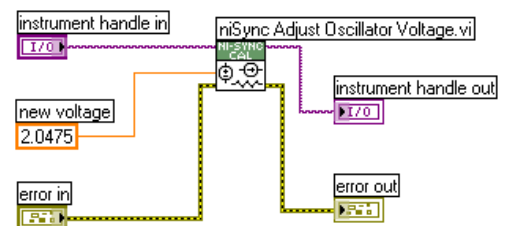
LabVIEW Block Diagram	NI-SYNC C Function Call
	<p>Call niSync_CalAdjustOscillatorVoltage with the following parameters:</p> <p>vi: "<SessionHandle>" newVoltage: <new control voltage> oldVoltage: *oldVoltage</p>

- c. Call niSync Close External Calibration VI to commit the settings and close the session.

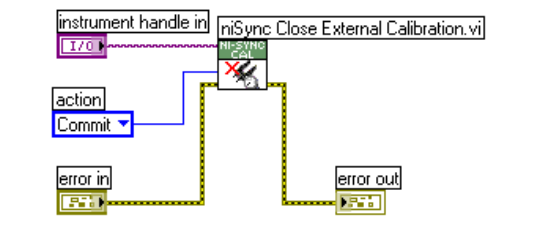
LabVIEW Block Diagram	NI-SYNC C Function Call
	<p>Call niSync_CloseExtCal with the following parameter:</p> <p>vi: "<SessionHandle>" action: NISYNC_VAL_EXT_CAL_COMMIT</p>

Reverification

After completing the adjustments to the NI PXI-665x, it is important that you verify the oscillator frequency operation by repeating the steps listed in the [Verification](#) section. Re-verifying after making the adjustments ensures that the NI PXI-665x is operating within its test limits.

Where to Go for Support

The National Instruments Web site is your complete resource for technical support. At ni.com/support you have access to everything from troubleshooting and application development self-help resources to email and phone assistance from NI Application Engineers.

National Instruments corporate headquarters is located at 11500 North Mopac Expressway, Austin, Texas, 78759-3504. National Instruments also has offices located around the world to help address your support needs. For telephone support in the United States, create your service request at ni.com/support and follow the calling instructions or dial 512 795 8248. For telephone support outside the United States, contact your local branch office:

Australia 1800 300 800, Austria 43 662 457990-0,
Belgium 32 (0) 2 757 0020, Brazil 55 11 3262 3599,
Canada 800 433 3488, China 86 21 5050 9800,
Czech Republic 420 224 235 774, Denmark 45 45 76 26 00,
Finland 358 (0) 9 725 72511, France 01 57 66 24 24,
Germany 49 89 7413130, India 91 80 41190000, Israel 972 3 6393737,
Italy 39 02 41309277, Japan 0120-527196, Korea 82 02 3451 3400,
Lebanon 961 (0) 1 33 28 28, Malaysia 1800 887710,
Mexico 01 800 010 0793, Netherlands 31 (0) 348 433 466,
New Zealand 0800 553 322, Norway 47 (0) 66 90 76 60,
Poland 48 22 328 90 10, Portugal 351 210 311 210,
Russia 7 495 783 6851, Singapore 1800 226 5886,
Slovenia 386 3 425 42 00, South Africa 27 0 11 805 8197,
Spain 34 91 640 0085, Sweden 46 (0) 8 587 895 00,
Switzerland 41 56 2005151, Taiwan 886 02 2377 2222,
Thailand 662 278 6777, Turkey 90 212 279 3031,
United Kingdom 44 (0) 1635 523545

CVI, National Instruments, NI, ni.com, and LabVIEW are trademarks of National Instruments Corporation. Refer to the *Terms of Use* section on ni.com/legal for more information about National Instruments trademarks. The mark LabWindows is used under a license from Microsoft Corporation. Windows is a registered trademark of Microsoft Corporation in the United States and other countries. Other product and company names mentioned herein are trademarks or trade names of their respective companies. For patents covering National Instruments products/technology, refer to the appropriate location: **Help»Patents** in your software, the `patents.txt` file on your media, or the *National Instruments Patent Notice* at ni.com/patents.