

SCXI™-MS100 TEMPERATURE MEASUREMENT SYSTEM

This guide describes how to install, configure, and use the SCXI-MS100 temperature measurement system.

Introduction

The SCXI-MS100 is a complete virtual-instrument-based temperature and voltage measurement system for Windows 2000/NT/98/95. The system includes the software and hardware needed to acquire and log up to 32 channels of data without any programming. You can configure each channel for thermocouple or voltage input, and add additional SCXI modules to expand the number of channels to 128.

The SCXI-MS100 is ideal for multichannel temperature applications in many environments, such as process monitoring, industrial automation, and instrumentation. The SCXI-MS100 combines SCXI and data acquisition (DAQ) products to take accurate temperature measurements with thermocouples. Taking measurements with thermocouples requires amplification, cold-junction compensation (CJC), and high-resolution analog-to-digital converters (ADCs). In addition, the included VirtualBench-Logger software is an interface you use to display and log data.

What You Need to Get Started

To set up and use your SCXI-MS100 temperature measurement system, you need the following:

- DAQ Quick Start Guide*
- SCXI Quick Start Guide*
- AT-MIO-16XE-50 or PCI-6035E data acquisition (DAQ) device

- SCXI-1000 chassis with AC power cord
- SCXI-1102 module
- SCXI-1303 terminal block
- SCXI-1349 cable assembly (cable and cable adapter)
- NI-DAQ driver software on CD-ROM, version 6.5.1 or later
- VirtualBench application software on CD-ROM, version 2.51 or later
- Flathead screwdriver
- Number 1 Phillips-head screwdriver

Install the Software and Hardware

The following sections detail how to install your software and hardware in your SCXI-MS100 system.



Note Install your software before you install your hardware.

Install the DAQ Device

To install the NI-DAQ driver software and the plug-in DAQ device, carefully follow the steps in the *DAQ Quick Start Guide* until the step that explains how to confirm that your DAQ device is operating properly. You do not need to go further since you will use VirtualBench-Logger to test your system.

Install VirtualBench-Logger

To install the VirtualBench-Logger, perform the following steps:

1. Insert the VirtualBench CD into your CD-ROM drive.
2. Click **Install VirtualBench** from the installation window that appears on your computer screen.
3. When prompted to select your VirtualBench components, select **Datalogger**.
4. The next screen to appear is entitled **Select Device Drivers**. Uncheck **NI-DAQ**, since the NI-DAQ driver was installed with your DAQ device. Leave **VISA** checked, unless NI-VISA (or a newer version of NI-VISA) was installed by another National Instruments software product such as LabVIEW.
5. Follow the installer prompts through the rest of the installation.

Install the SCXI Hardware Components

To install the SCXI hardware components, carefully follow the steps shown in the *SCXI Quick Start Guide*. This procedure includes instructions on how to set up your SCXI chassis, install SCXI modules, attach terminal blocks and cables, configure your SCXI chassis using Measurement & Automation Explorer, and test to determine that your chassis is configured properly.



Caution Do not insert an SCXI module into a chassis that is powered on.

Connect the Thermocouples

To connect thermocouple lead wires to the SCXI-1303 terminal block, refer to Figures 1 and 2 as necessary while you perform the following steps:

1. Unscrew the top cover screws and remove the cover.
2. Loosen the strain-relief screws and remove the strain-relief bar.

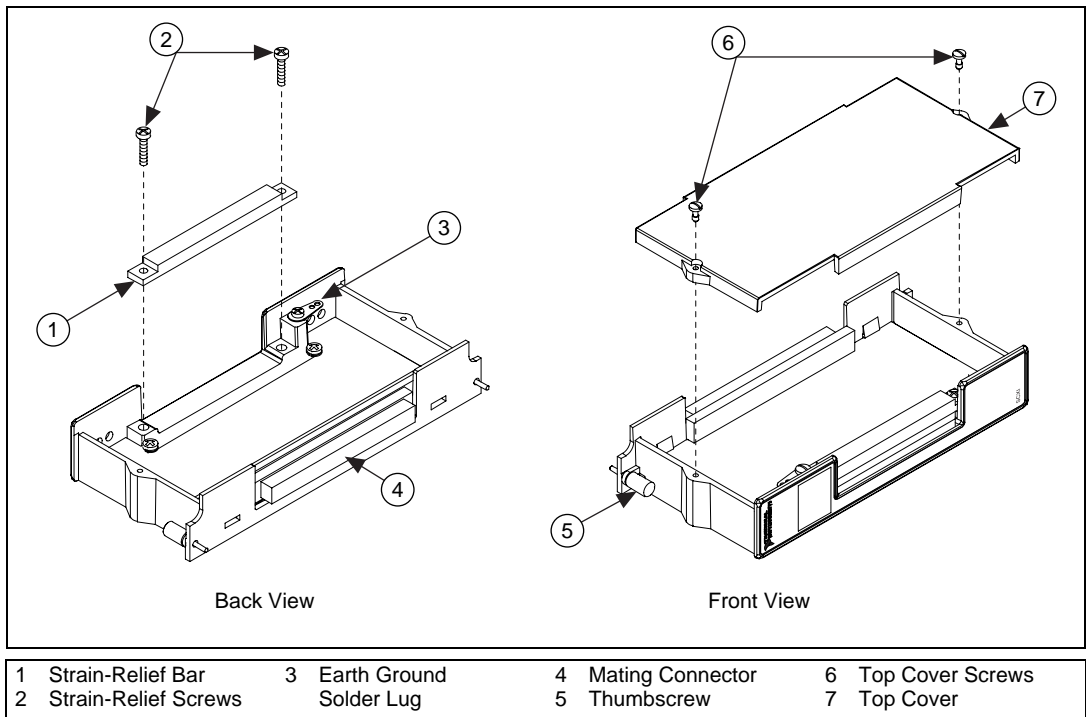

Figure 1. SCXI-1303 Parts Locator Diagram

3. Slide the thermocouple (included with your kit) through the strain-relief opening. You can add insulation or padding if necessary.
4. To connect the wires to the SCXI-1303 screw terminals, insert the wires into the terminals and tighten the screws with a flathead screwdriver. Refer to Figure 2 to install the J-type thermocouple on channel 0.
5. Tighten the screw terminal to a torque of 5-7 in.-lb.
6. Reinstall the strain-relief bar and tighten the strain-relief screws.
7. Reinstall the top cover and tighten the top-cover screws.

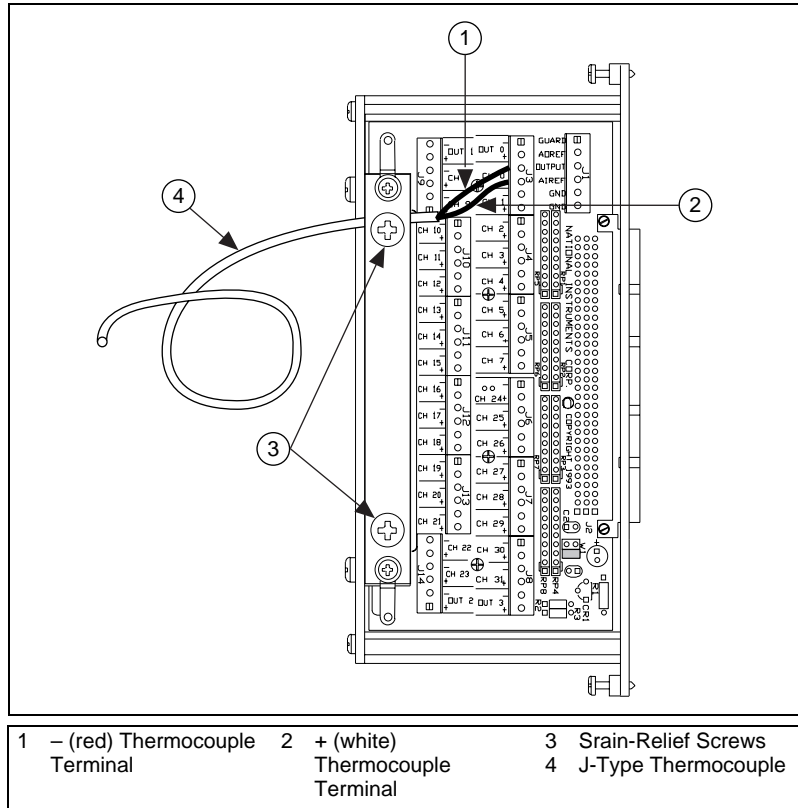

Figure 2. Thermocouple Connected to Channel 0 of the SCXI-1303 Terminal Block

You are ready to connect the SCXI-1303 terminal block to the SCXI-1102 module front connector.

Connect the SCXI-1303 to Your SCXI-1102 Module

To connect the SCXI-1303 terminal block to your SCXI-1102 module front connector, refer to Figure 3 and perform the following steps:

1. Turn off your SCXI-1000 chassis.
2. Connect the SCXI-1303 terminal block to the SCXI-1102 module front connector.
3. Make sure that the SCXI-1102 module top and bottom thumbscrews do not obstruct the rear panel of the SCXI-1303 terminal block.
4. Tighten the top and bottom thumbscrews on the back of the terminal block to hold it securely in place and to ensure proper shielding.
5. Turn on the SCXI-1000 chassis power.

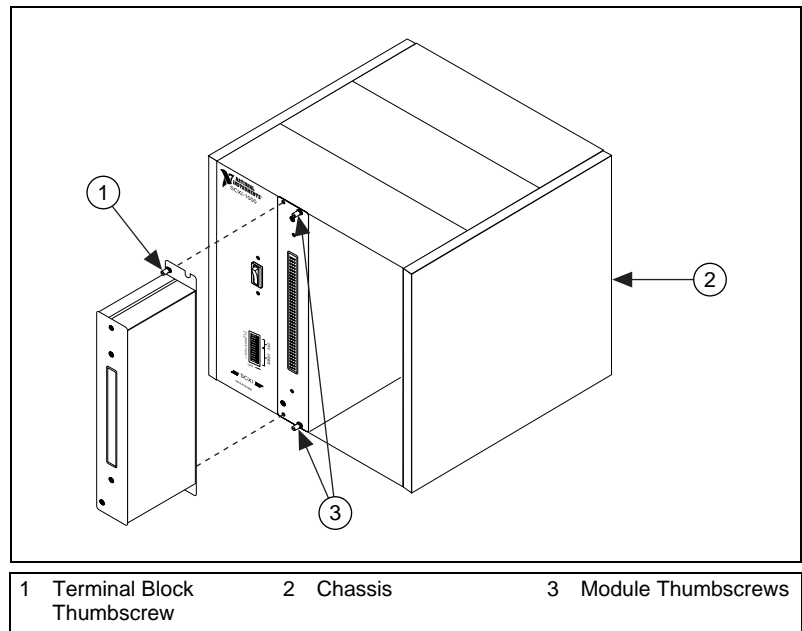

Figure 3. Connecting the SCXI-1303 Terminal Block to the SCXI-1102 Module



Note Place the SCXI chassis away from any extreme temperature differential to minimize the temperature gradient inside the terminal block and maintain its isothermal nature for accurate cold-junction compensation.

Before you continue, confirm that your system resembles the system shown in Figure 4.

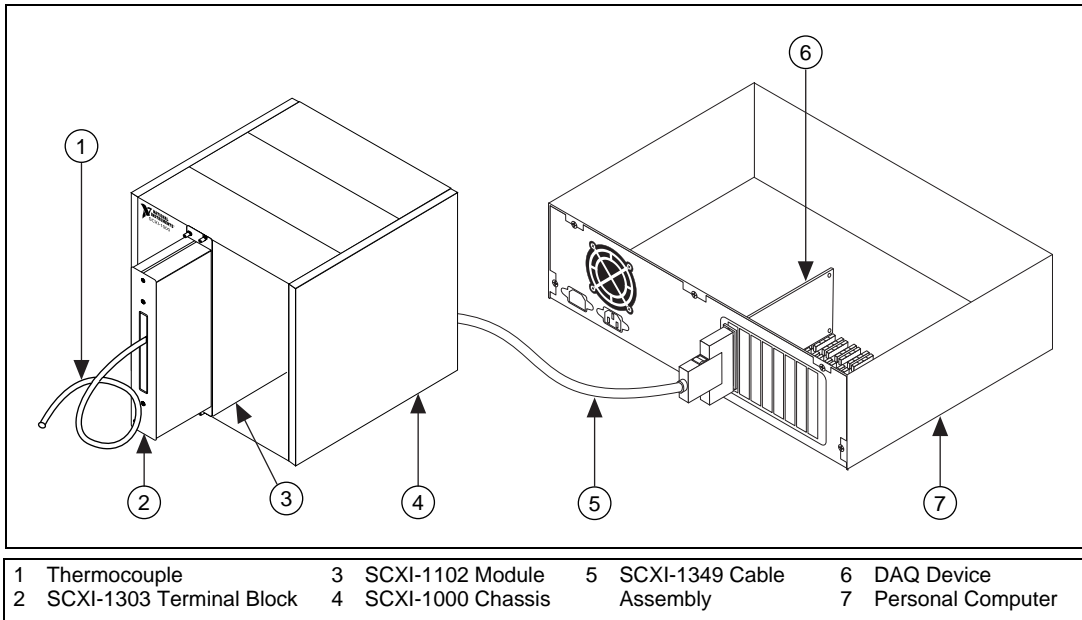

Figure 4. Complete Installation

Configure the System

To complete the configuration of your SCXI-MS100 system using Measurement & Automation Explorer, perform the following steps:

1. Double-click the **Measurement & Automation Explorer** icon on your desktop.
2. Click the + next to the **Devices and Interfaces** icon to display the list of installed devices and interfaces.
3. Locate the SCXI-1000 chassis in the list. If the chassis is not listed, return to the *Install the SCXI Hardware Components* section.
4. Click the + next to the **Chassis** icon to display the SCXI-1102 module in the chassis.
5. Right-click the SCXI-1102 module and select **Properties**.

- Click the **General** tab shown in Figure 5 and the **Channel** tab shown in Figure 6. All items on both the **General** and **Channel** tabs should have defaulted to the correct settings. If the default settings are incorrect or incomplete, change them as needed as shown in Figure 5 and 6.

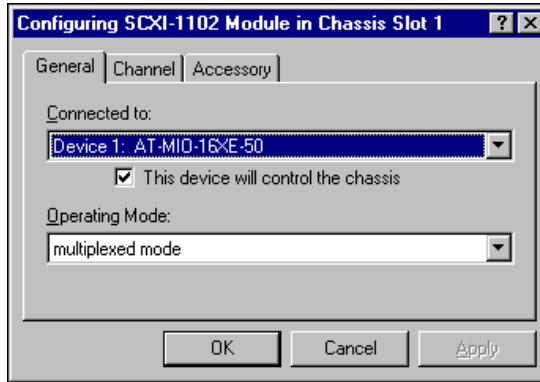

Figure 5. SCXI Module General Tab

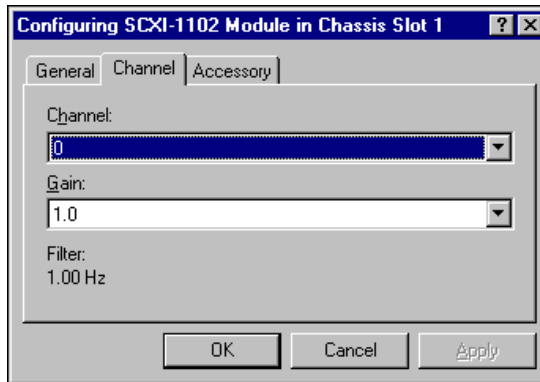

Figure 6. SCXI Module Channel Tab

7. Click the **Accessory** tab shown in Figure 7. Set the **Accessory** option to SCXI-1303 and click **OK**.

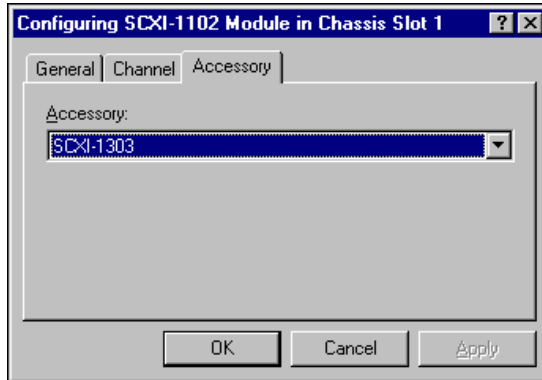

Figure 7. SCXI Module Accessory Tab

You can exit Measurement & Automation Explorer before using VirtualBench-Logger.

Configure VirtualBench-Logger

From Windows, run the VirtualBench-Logger software, located under **Start»Programs»National Instruments VirtualBench»VirtualBench-Logger**. Figure 8 shows the main run-time window for the VirtualBench-Logger.

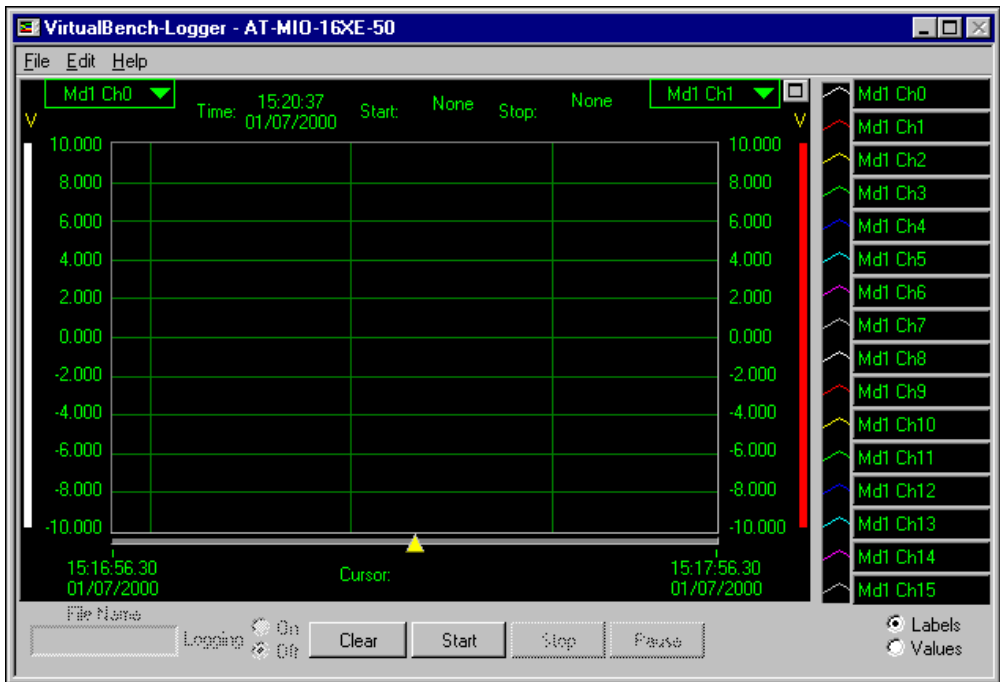

Figure 8. VirtualBench-Logger Main Run-Time Window

To configure the settings in the VirtualBench-Logger, select **Edit»Settings**.

Figure 9 shows the **Logger Settings** window.

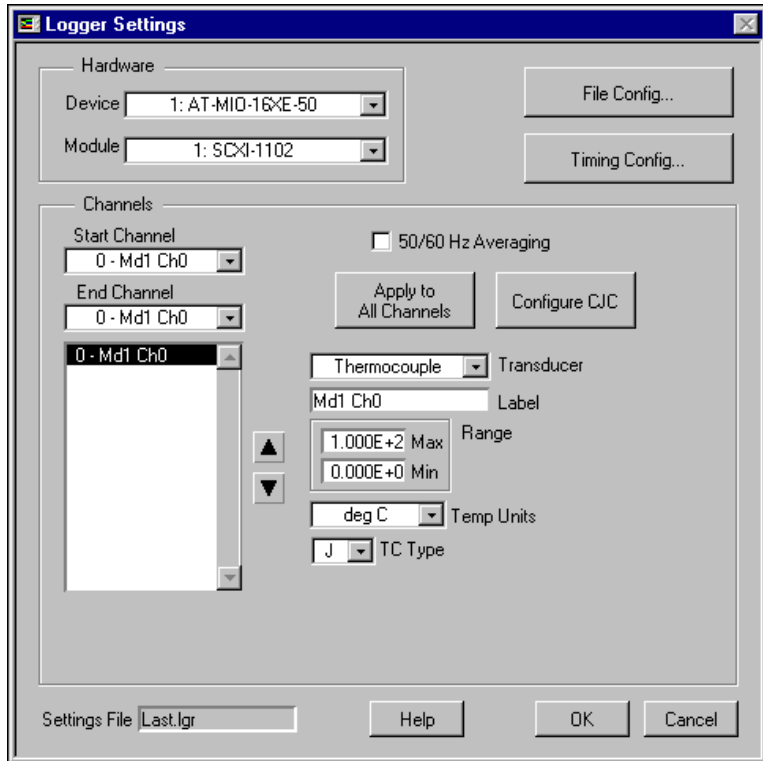

Figure 9. VirtualBench-Logger Settings Window

To configure VirtualBench-Logger for use with an installed thermocouple, complete the following steps:

1. In the **Hardware** box, set the **Device** to **1: AT-MIO-16XE-50** or **1: PCI-6035E**.
2. Set the **Module** to **1: SCXI-1102**.
3. In the **Channels** box, set the **End Channel** to **0 - Md1 Ch0**.
4. Set the **Transducer** type to **Thermocouple**.
5. Set the **Max** input range to **1.000E+2**.
6. Set the **Min** input range to **0.000E+0**.
7. Set the **Temp Units** type to **deg C**.
8. Set the **TC Type** to **J**.
9. Click the **Configure CJC** button.

Figure 10 shows the **CJC Configuration** window.

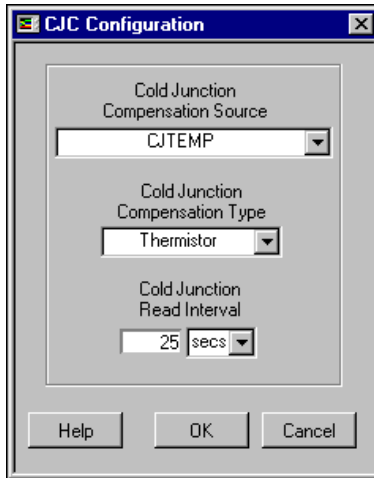

Figure 10. CJC Configuration Window

To configure your CJC source, complete the following steps:

1. Set the **Cold Junction Compensation Source** to **CJTEMP**.
2. Set the **Cold Junction Compensation Type** to **Thermistor**.
3. Click **OK**.

Click **OK** on the Logger Settings window, as shown in Figure 9, to return to the main run-time window.

Collect Temperature Data Using VirtualBench-Logger

You are now ready to collect temperature data. Press the **Start** button on the main run-time window; the **VirtualBench-Logger** window displays temperature data from the thermocouple.

For more information on configuring the VirtualBench-Logger and using its data-logging capabilities, refer to the *VirtualBench Online Help* located under the **Help** menu.

Expand for More Channels

Up to this point, this installation guide has explained how to use only one channel. To connect and measure more thermocouple or voltage signals, read the following sections.

Up to 32 Channels

The factory-default SCXI-MS100 system accommodates up to 32 channels. To measure and log up to 32 thermocouple or voltage inputs, perform the following steps:

1. Remove the SCXI-1303 terminal block. Refer to [Connect the Thermocouples](#) and [Connect the SCXI-1303 to Your SCXI-1102 Module](#) to connect the additional signals and reinstall the SCXI-1303. Make sure you connect the signals to consecutive input channels.
2. Run the VirtualBench-Logger software and go to **Edit>Settings**. Modify the **Start Channel** and **End Channel** to reflect the number of thermocouple or input signals that you have connected.

More Than 32 Channels

You can expand the SCXI-MS100 system beyond 32 channels by adding up to three SCXI-MS100 32-channel expansion kits. Each kit includes one SCXI-1102 module and one SCXI-1303 terminal block.

To integrate an SCXI-MS100 32-channel expansion kit into your system, perform the following steps:

1. Power off the SCXI-1000 chassis.
2. Install the SCXI-1102 module into the next available slot.
3. Connect the additional signals and install the SCXI-1303 by referring to [Connect the Thermocouples](#) and [Connect the SCXI-1303 to Your SCXI-1102 Module](#). Make sure you connect the signals to consecutive input channels.
4. Power on the SCXI-1000 chassis.
5. Double-click the **Measurement & Automation Explorer** icon on your desktop.
6. Click the + next to the **Devices and Interfaces** icon to display the list of installed devices and interfaces.
7. Locate the SCXI-1000 chassis in the list. Display the list of modules in the chassis by clicking the + next to the **Chassis** icon.
8. Right-click the appropriate installation slot and select **Insert**.
9. Select **SCXI-1102** from the list and click **Next**.
10. Configure the module as described in [Configure the System](#) and shown in Figures 5, 6, and 7.
11. Exit Measurement & Automation Explorer.
12. Run the VirtualBench-Logger.
13. Go to **Edit>Settings** to set up the channels on the new SCXI-1102 as described in [Configure VirtualBench-Logger](#).