

TBX-1303 32-CHANNEL ISOTHERMAL TERMINAL BLOCK INSTALLATION GUIDE

This guide describes how to install the National Instruments TBX-1303 32-channel isothermal terminal block and how to use it with SCXI-1100 and SCXI-1102/B/C modules.

The TBX-1303 is a DIN rail-mountable terminal block that connects through a cable to the SCXI-1100 or SCXI-1102/B/C module input connector. The TBX-1303 has a high-accuracy thermistor, cold-junction temperature sensor, and an isothermal copper plane to minimize the temperature gradients across the screw terminals when you take measurements with thermocouples. The TBX-1303 mounts on most European standard DIN EN mounting rails.

The TBX-1303 has 108 screw terminals. Thirty-two sets of three screw terminals connect to the 32 differential inputs of the SCXI module and shield each input. One pair of terminals labeled **GND** connects to the chassis ground pins of the SCXI module. All the other terminals—**AIREF**, **AOREF**, **GUARD**, **OUT0+**, **OUT0-**, **OUT1+**, **OUT1-**, **OUTPUT**, and their shields—are reserved for future use.

National Instruments™, NI™, ni.com™, and SCXI™ are trademarks of National Instruments Corporation. Product and company names mentioned herein are trademarks or trade names of their respective companies. For patents covering National Instruments products, refer to the appropriate location: **Help»Patents** in your software, the `patents.txt` file on your CD, or ni.com/patents.

June 2002
371205A-01

Conventions

The following conventions are used in this guide:



Angle brackets that contain numbers separated by an ellipsis represent a range of values associated with a bit or signal name—for example, DBIO<3..0>. Angle brackets can also denote a variable in a channel name—for example, ACH<i>.



The » symbol leads you through nested menu items and dialog box options to a final action. The sequence **File»Page Setup»Options** directs you to pull down the **File** menu, select the **Page Setup** item, and select **Options** from the last dialog box.



This icon denotes a note, which alerts you to important information.



This icon denotes a caution, which advises you of precautions to take to avoid injury, data loss, or a system crash. When this symbol is marked on the product, refer to the *Read Me First: Safety and Radio-Frequency Interference* document, shipped with the product, for precautions to take.

bold

Bold text denotes items that you must select or click in the software, such as menu items and dialog box options. Bold text also denotes parameter names and hardware labels.

italic

Italic text denotes variables, emphasis, a cross reference, or an introduction to a key concept. This font also denotes text that is a placeholder for a word or value that you must supply.

monospace

Text in this font denotes text or characters that you should enter from the keyboard, sections of code, programming examples, and syntax examples. This font is also used for the proper names of disk drives, paths, directories, programs, subprograms, subroutines, device names, functions, operations, variables, filenames and extensions, and code excerpts.

What You Need to Get Started

To install and use the TBX-1303, you need the following items:

- TBX-1303 32-channel isothermal terminal block kit
 - TBX-1303 32-channel isothermal terminal block
 - *TBX-1303 32-Channel Isothermal Terminal Block Installation Guide*
 - Four 10 M Ω resistor networks
 - 1/8 in. flathead screwdriver

- Read Me First: Safety and Radio-Frequency Interference*
- SCXI chassis and documentation
- One of the following modules:
 - SCXI-1100 module and documentation
 - SCXI-1102/B/C module and documentation
- One of the following cable assemblies:
 - SH96-96
 - R9696
 - SBS-96F shielded backshell
- Long-nose pliers
- 3/16 in. wrench
- Number 1 Phillips screwdriver
- TBX rack-mount kit (optional)
 - TBX rack-mount assembly
 - *TBX Rack-Mount Kit Installation Guide*
 - Four 10-32 screws

Installing the TBX-1303

Perform the following steps to mount the SH96-96 cable assembly and connect the TBX-1303 to the SCXI module. Refer to Figures 1 and 2 as needed.



Caution Refer to the *Connecting Signals* section before connecting the signals. If signal wires are connected to the terminal block, dangerous voltages can exist even when the equipment is powered off.

1. Power off the SCXI chassis.
2. Power off the computer that contains the E Series data acquisition (DAQ) device, or disconnect the device from the SCXI chassis.
3. Connect the TBX cable adapter to the SCXI module, and secure the adapter by tightening both thumbscrews.

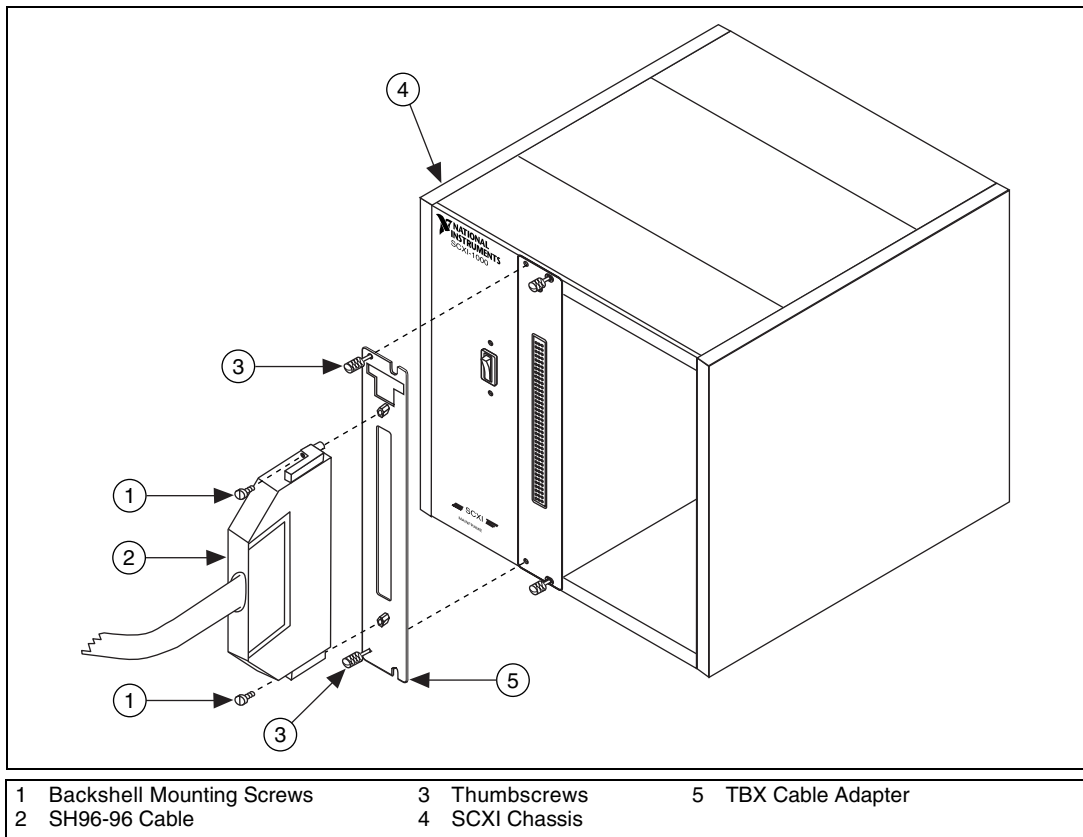

Figure 1. Connecting the SH96-96 Cable to the SCXI Module

4. Connect either end of the SH96-96 cable to the TBX cable adapter and SCXI module, and secure the cable by tightening both backshell mounting screws.
5. Connect the other end of the cable to the TBX-1303 terminal block connector, and secure the cable by tightening both backshell mounting screws.



Note To minimize the temperature gradient inside the terminal block and to maintain its isothermal properties for accurate cold-junction compensation (CJC), keep the TBX-1303 terminal block away from extreme temperature differentials.

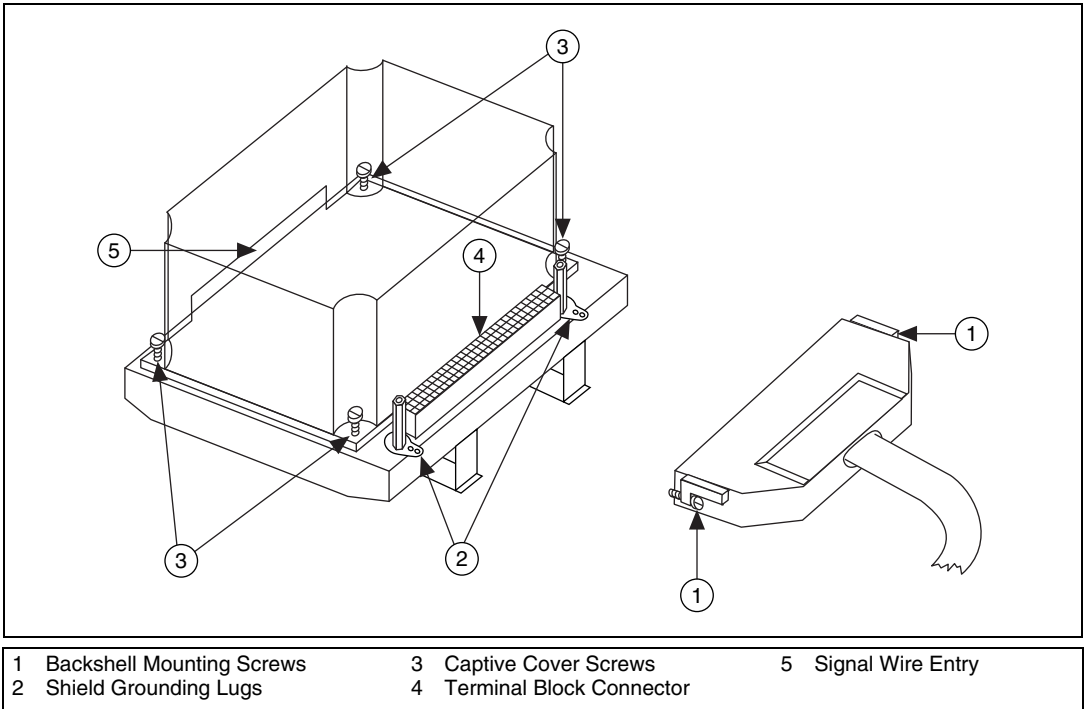

Figure 2. Connecting the SH96-96 Cable to the TBX-1303 Terminal Block



Note The SH96-96 cable is not shown in the exact position for proper connection to the terminal block connector. Refer to Figure 3 for the completed installation.

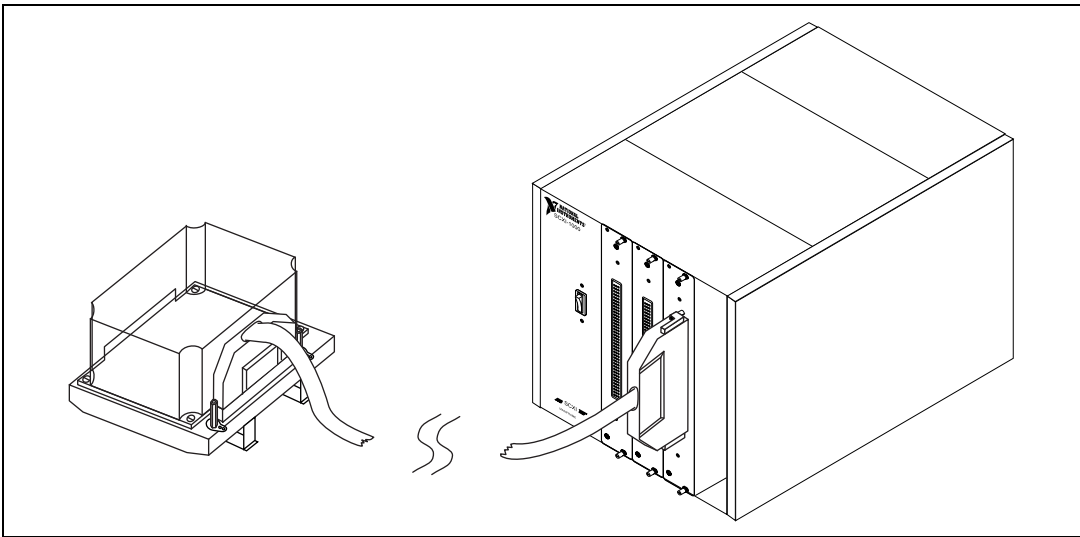

Figure 3. Completed Installation

Rack Mounting

When you complete the installation, you can mount the TBX assembly on the rack. If you are using the NI TBX rack-mount assembly, refer to the *TBX Rack-Mount Installation Guide*, which you can download from ni.com/manuals, for instructions. If you are not using this rack-mount assembly, complete the following steps to mount the TBX assembly directly onto the DIN rail.

1. Snap the TBX terminal block onto the DIN rail with a firm push.
2. Install the SCXI chassis using the appropriate chassis rack-mount kit.



Note To remove the TBX terminal block from the DIN rail, place a flathead screwdriver into the slot above the terminal block base, and pry it from the rail.

Connecting Signals



Caution Do *not* connect hazardous voltage levels (≥ 42 V) to this product.

To connect field signals to the TBX-1303 for use with the SCXI-1100 or SCXI-1102/B/C module, refer to Figures 2 and 4 as you complete the following steps.

1. Unscrew the four captive cover screws in the corners of the TBX-1303 terminal block and remove the cover.
2. Connect the signal wires to the screw terminals. Refer to the SCXI module user manual for examples of how to connect to field signals and loads. Route the signal wires through the signal wire entry, shown in Figure 2.



Note The GND terminals are connected to the SCXI module chassis ground through the cable, not the shield. In addition, each channel has its own shield terminal (labeled **S** on the board) for connecting signal shields. The TBX-1303 has corresponding rows labeled **A**, **B**, and **C**, as shown in Figure 4, to help you make the correct connections.

3. Verify that you have the resistor networks appropriate to the SCXI module, signal type, and application. Refer to Table 4 for information about selecting the appropriate resistor networks.
4. Replace the TBX-1303 terminal block cover and tighten the captive cover screws.



Note This terminal block does not provide strain relief for field signal wires. If necessary, add strain relief, insulation, and padding for the field signal wires.

The installation and signal connection are now complete.

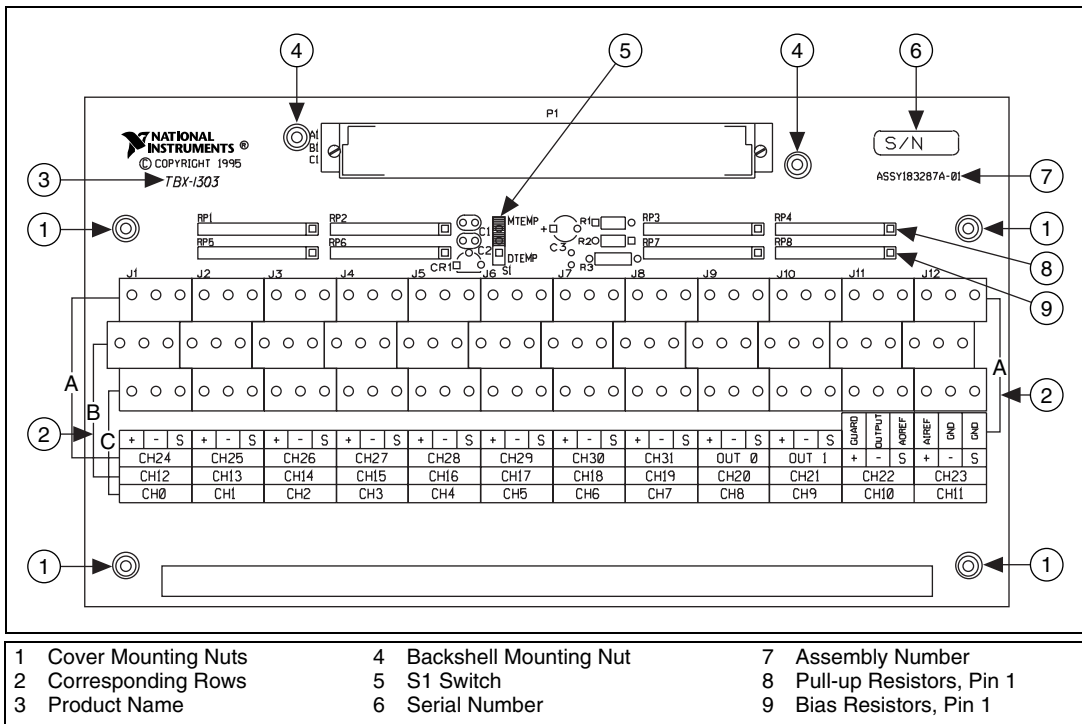

Figure 4. TBX-1303 Parts Locator Diagram

Configuring the Temperature Sensor



To enable you to use thermocouples with SCXI modules, the TBX-1303 has a thermistor temperature sensor for CJC.

You can connect the temperature sensor to an SCXI module in one of two ways:

- Multiplexed temperature sensor (MTEMP) mode—set the TBX-1303 terminal block switch S1 to the MTEMP position. This setting is the factory default. Refer to Figure 4 for the location of switch S1.
- Direct temperature sensor (DTEMP) mode—set the TBX-1303 terminal block switch S1 to the DTEMP position. This mode connects the temperature sensor to a separate DAQ channel through the SCXI module. Refer to the SCXI module user manual to configure the SCXI module for DTEMP mode.

Table 1 shows the terminal block switch settings.

Table 1. Switch S1 Settings

Switch S1 Position	Description
 <p>MTEMP</p> <p>DTEMP</p>	MTEMP mode selected; factory setting; preferred mode and parking position
 <p>MTEMP</p> <p>DTEMP</p>	DTEMP mode selected; connects to a separate DAQ channel



Note On the SCXI-1102/B/C module, MTEMP mode is the only supported mode.

Temperature Sensor Output and Accuracy

The TBX-1303 temperature sensor voltage output varies from 1.91 to 0.58 V over the 0 to 55 °C temperature range. The temperature sensor output accuracy is shown in Table 2.

Table 2. Temperature Sensor Voltage Output Accuracy

Temperature Range	Voltage Output Accuracy ¹
0 to 15 °C	±1.0 °C
15 to 35 °C	±0.65 °C
35 to 55 °C	±1.0 °C
¹ Includes the combined effects of the temperature sensor accuracy and the temperature difference between the temperature sensor and any screw terminal. The temperature sensor accuracy includes tolerances in all component values, and the effects caused by temperature, loading, and self-heating.	

To select and read the temperature sensor, refer to the driver software documentation for programming information.

Alternatively, you can follow these steps to convert the cold-junction sensor voltage to the cold-junction temperature.

1. Calculate the resistance of the thermistor in Ω .

$$R_T = 5,000 \left(\frac{V_{TEMPOUT}}{2.5 - V_{TEMPOUT}} \right)$$

$V_{TEMPOUT}$ = output voltage of the temperature sensor



Note $V_{TEMPOUT}$ varies from 1.91 V (at 0 °C) to 0.58 V (at 55 °C). For the best resolution, use the maximum gain for this signal range on the analog input channel of the DAQ device.

The SCXI-1100 does not have a filter on the $V_{TEMPOUT}$ signal. Therefore, use an average of a large number of samples to obtain an accurate measurement. For example, sample for one second and average. Noisy environments require more samples for greater accuracy.

The SCXI-1102/B/C has a 2 Hz filter on the $V_{TEMPOUT}$ signal input channel (MTEMP).

2. Calculate the cold-junction temperature in Kelvin.

$$T_K = \frac{1}{\left[a + b(\ln R_T) + c(\ln R_T)^3 \right]}$$

$$a = 1.295361 \times 10^{-3}$$

$$b = 2.343159 \times 10^{-4}$$

$$c = 1.018703 \times 10^{-7}$$

R_T = resistance of the thermistor

3. Convert the temperature to Celsius and Fahrenheit.

$$T(^{\circ}\text{C}) = T_K - 273.15$$

T_K = temperature in Kelvin

$$T(^{\circ}\text{F}) = \frac{[T(^{\circ}\text{C})]9}{5} + 32$$

where $T(^{\circ}\text{F})$ and $T(^{\circ}\text{C})$ are the temperature readings in degrees Fahrenheit and Celsius, respectively.

Temperature Sensor Circuit Diagram

Use the circuit diagram in Figure 5 for optional information and more details about the TBX-1303 temperature sensor.

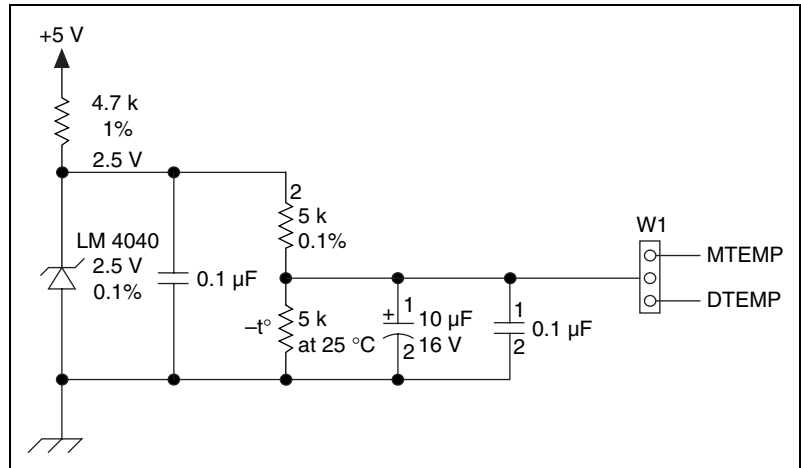

Figure 5. Temperature Sensor Circuit Diagram

Configuring the Resistor Networks

The TBX-1303 has a pull-up resistor connected between CH+ and +5 V and has a bias resistor connected between CH- and chassis ground. These resistors help detect open thermocouples by detecting module amplifier output saturation. The TBX-1303 ships with 10 Ω and 10 M Ω resistor networks. Depending on the SCXI module you use with the TBX-1303, you might need to change from the default 10 Ω configuration to the 10 M Ω configuration. Figure 6 shows how the pull-up and bias resistors connect to the CH \pm inputs.

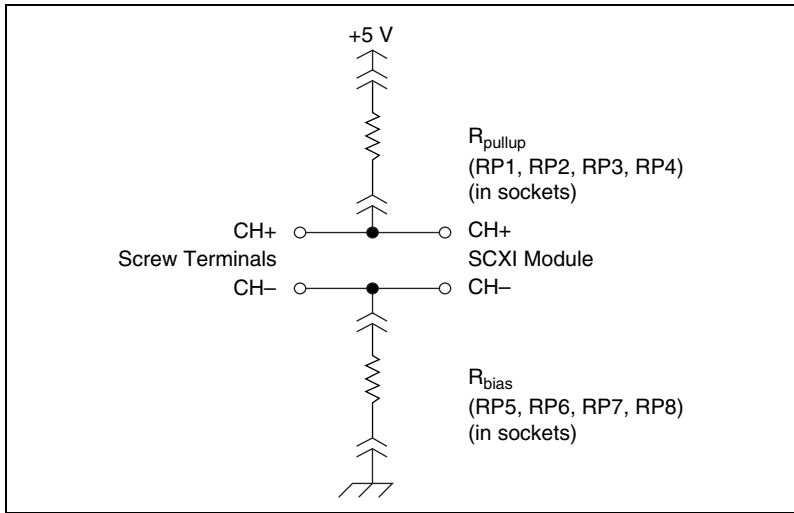

Figure 6. Resistor Connections

A package of four 10 M Ω resistor networks is included in the TBX-1303 kit. You can install these resistor networks as RP5, RP6, RP7, and RP8. Refer to Figure 4 for placement. With this configuration, thermocouples are either ground-referenced or floating.

Table 3 shows the relationship between the channel input signals and the resistor networks.

Table 3. Channel Input Signals and Resistor Networks

Channel	Pull-up Resistor Network	Bias Resistor Network
<0..7>	RP1	RP5
<8..15>	RP2	RP6
<16..23>	RP3	RP7
<24..31>	RP4	RP8

Table 4 shows which resistor networks to use for the SCXI module, signal type, and application.

Table 4. Selecting the Appropriate Resistor Networks

Module	Bias Resistor	Pull-up Resistor	Source Impedance	Signal (Floating or Ground-Referenced)	Open Thermocouple Detection	Comments
SCXI-1102/B/C	10 M Ω	10 M Ω	Low	Both	Yes	Recommended configuration for the SCXI-1102/B/C
	10 Ω	10 M Ω	Low	Floating	Yes	Factory-default configuration
	10 Ω	None	High or low	Floating	No	—
	None	None	High or low	Ground-referenced	No	—
SCXI-1100	10 M Ω	10 M Ω	—	—	—	Not recommended
	10 Ω	10 M Ω	Low	Floating	Yes	Factory-default configuration
	10 Ω	None	High or low	Floating	No	—
	None	None	High or low	Ground-referenced	No	—
Low source impedance: $\leq 50 \Omega$ High source impedance: $> 50 \Omega$						



Caution Connecting an external ground-referenced signal with the 10 Ω resistor network in place can cause permanent damage to the resistor network and the traces on the TBX-1303 printed circuit board. NI is *not* liable for any damage or injuries resulting from improper signal connections.

Detecting Open Thermocouples

To detect an open thermocouple, check whether the corresponding SCXI module channel is saturated. The pull-up and bias resistors on the TBX-1303 saturate the channel by applying +5 V at the input of an open channel, and the positive rail saturates.

SCXI-1102/B/C Module

You can replace the 10 Ω bias resistor networks (factory-default configuration) in the TBX-1303 with the 10 M Ω resistor networks supplied in the kit. Using the 10 M Ω resistor networks, you can have ground-referenced or floating signals. The channels with open thermocouples saturate at all sample rates of the module.

Use long-nose pliers to remove or replace the resistor networks in the sockets; be careful not to damage the network package. Make sure pin 1 of each network is in the correct socket. Refer to Figures 4 and 7 for correct network placement.

Each network is labeled with descriptive numbers on the left front side, and pin 1 is located directly beneath the black dot within these numbers. The $10\ \Omega$ resistor network is labeled **10x-1-100** ($10 \times 10^0\ \Omega$); the $10\ \text{M}\Omega$ resistor network is labeled **10x-1-106** ($10 \times 10^6\ \Omega$). Figure 7 shows examples of these resistor networks.

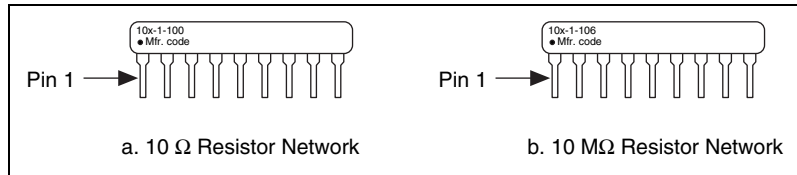

Figure 7. Resistor Networks

SCXI-1100 Module

For the open thermocouple channel to saturate without disturbing the measurements on any other channel, use an interchannel delay of $200\ \mu\text{s}$ at a gain of 100 or higher, which corresponds to a sample rate of 5 kHz.

After installing the $10\ \Omega$ bias resistors, you can accurately measure at the maximum sampling rate of the module. The open thermocouple channel may not saturate if the interchannel delay is less than $200\ \mu\text{s}$ or if the sample rate is more than 5 kHz at a gain of 100 or higher.

If you want fast open thermocouple detection and you have short thermocouple leads, or if high accuracy is not important, you can replace the pull-up resistors with a lower value resistor network. For example, you can replace the pull-up resistor with a $1\ \text{M}\Omega$, 10-pin based configuration resistor network (not included) and have a sample rate of 20 kHz (interchannel delay of $50\ \mu\text{s}$ typical). With a $10\ \Omega$ bias resistor network, the current leakage would be $5\ \mu\text{A}$ ($5\ \text{V} \div 1\ \text{M}\Omega$), which can result in a larger offset error because of thermocouple lead resistance.

Use long-nose pliers to remove or replace the resistor networks in the sockets; be careful not to damage the network package. Make sure that pin 1 of each network is in the correct socket. Refer to Figures 4 and 7 for correct network placement.

Errors Due to Open-Thermocouple Detection Circuitry

Open-thermocouple detection circuitry can cause two types of measurement errors. These errors are the results of common-mode voltage at the input of the SCXI module and current leakage into the signal leads.

Common-Mode Voltage at the Input of the SCXI Module

With 10 M Ω pull-up and bias resistors, a common-mode voltage of 2.5 VDC develops if the thermocouple is floating. At a gain of 100, the common-mode rejection of the SCXI-1102/B/C module is sufficiently high so that the resulting offset voltage is negligible.

If the application demands extremely high accuracy, you can eliminate this offset error by calibrating the system. Refer to the module documentation for more information on calibration. You can also remove the pull-up resistor, which eliminates the open-thermocouple detection feature, or use the 10 Ω bias resistor networks, which bring the common-mode voltage down to nearly 0 VDC.

Current Leakage

The open-thermocouple detection circuitry results in a small current leakage into the thermocouple. With the 10 M Ω bias and pull-up resistor networks, the current leakage results in a negligible error. With the 10 Ω bias resistor, the 10 M Ω pull-up resistor connected to 5 VDC causes a current leakage of approximately 0.5 μ A ($5 \text{ V} \div 10 \text{ M}\Omega$) to flow into the unbroken thermocouple.

If the thermocouple is lengthy, a voltage drop develops in the thermocouple because of lead resistance. For example, if you have a 24 AWG J-type thermocouple that is 20 feet long, a voltage drop of approximately 8 μ V can develop in the thermocouple, which corresponds to an error of 0.18 $^{\circ}$ C. The following equation shows how to arrive at the voltage drop value:

$$(0.145 \text{ } \Omega/\text{ft} + 0.658 \text{ } \Omega/\text{ft}) \times 20 \text{ ft} \times 0.5 \text{ } \mu\text{A}$$

If the application demands high accuracy, you can eliminate this error by removing the appropriate pull-up resistor network or by calibrating the system offset.

Specifications

All specifications are typical at 25 °C unless otherwise specified.

Electrical

Cold-junction sensor

Accuracy ¹	0.65° from 15 to 35 °C 1.0° from 0 to 15 °C and 35 to 55 °C
Repeatability	0.35° from 15 to 35 °C
Output	1.91 (at 0 °C) to 0.58 V (at 55 °C)

Open thermocouple detection

Pull-up resistor.....	10 MΩ
Bias resistor	10 Ω or 10 MΩ
Field wire gauge	26 to 14 AWG

Physical

Compatible DIN rails.....	DIN EN 50 022 DIN EN 50 035
Terminal block dimensions	19.81 by 7.62 by 11.18 cm (7.8 by 3 by 4.4 in.)

Maximum Working Voltage

Maximum working voltage (signal + common mode)	Each input should remain within ±10 V of chassis ground
---	--

¹ Includes the combined effects of the temperature sensor accuracy and the temperature difference between the temperature sensor and any screw terminal. The temperature sensor accuracy includes tolerances in all component values, the effects caused by temperature and loading, and self-heating.

Safety

The TBX-1303 was evaluated using the criteria of EN 61010-1 A-2:1995 and meets the requirements of the following standards for safety and electrical equipment for measurement, control, and laboratory use:

- EN 61010-1:1993/A2:1995, IEC 61010-1:1990/A2:1995
- UL 3101-1:1993, UL 3111-1:1994, UL 3121:1998
- CAN/CSA c22.2 no. 1010.1:1992/A2:1997

Electromagnetic Compatibility

EMC/EMI.....	CE, C-Tick, and FCC Part 15 (Class A) Compliant
Electrical emissions.....	EN 55011 Class A at 10 meters FCC Part 15A above 1 GHz
Electrical immunity.....	Evaluated to EN 61236:1998, Table 1



Note For full EMC compliance, you must operate this device with shielded cabling. In addition, all covers and filler panels must be installed. Refer to the DoC for this product for any additional regulatory compliance information. To obtain the DoC for this product, click **Declaration of Conformity Information** at ni.com/hardref.nsf/. This Web site lists the DoCs by product family. Select the appropriate product family, followed by the product, and a link to the DoC appears in Adobe Acrobat format. Click the Acrobat icon to download or read the DoC.

Technical Support Resources

NI Web Support

NI Web support is your first stop for help in solving installation, configuration, and application problems and questions. Online problem-solving and diagnostic resources include frequently asked questions, knowledge bases, product-specific troubleshooting wizards, manuals, drivers, software updates, and more. Web support is available through the Technical Support section of ni.com.

Worldwide Support

NI has offices located around the world to help address your support needs. You can access our branch office Web sites from the Worldwide Offices section of ni.com. Branch office Web sites provide up-to-date contact information, support phone numbers, email addresses, and current events.

If you have searched the technical support resources on our Web site and still cannot find the answers you need, contact your local office or NI corporate. For telephone support in the United States, dial 512 795 8248. For telephone support outside the United States, contact your local branch office:

Australia 03 9879 5166, Austria 0662 45 79 90 0, Belgium 02 757 00 20, Brazil 011 3262 3599, Canada (Calgary) 403 274 9391, Canada (Montreal) 514 288 5722, Canada (Ottawa) 613 233 5949, Canada (Québec) 514 694 8521, Canada (Toronto) 905 785 0085, China 86 21 6555 7838, Czech Republic 02 2423 5774, Denmark 45 76 26 00, Finland 09 725 725 11, France 01 48 14 24 24, Germany 089 741 31 30, Greece 01 42 96 427, Hong Kong 2645 3186, India 91 80 4190000, Israel 03 6393737, Italy 02 413091, Japan 03 5472 2970, Korea 02 3451 3400, Malaysia 603 9596711, Mexico 001 800 010 0793, Netherlands 0348 433466, New Zealand 09 914 0488, Norway 32 27 73 00, Poland 22 3390 150, Portugal 210 311 210, Russia 095 238 7139, Singapore 65 6 226 5886, Slovenia 3 425 4200, South Africa 11 805 8197, Spain 91 640 0085, Sweden 08 587 895 00, Switzerland 056 200 51 51, Taiwan 02 2528 7227, United Kingdom 01635 523545