

TBX-1326 HIGH-VOLTAGE TERMINAL BLOCK

This guide describes how to install and use the National Instruments TBX-1326 high-voltage terminal block with the SCXI-1162/HV, SCXI-1163, and SCXI-1163R modules.

The TBX-1326 is a DIN-rail mountable terminal block that connects to an SCXI module front connector with an SH48-48-B cable. The TBX-1326 mounts on most European standard DIN EN mounting rails.

The TBX-1326 has 48 screw terminals arranged in eight groups of six terminals, called *banks*. Each bank is isolated from all the other banks. The six terminals in a bank consist of a positive supply voltage (V_{cc}), a ground (GND), and four channels (CH(X)). Table 1 summarizes how the TBX-1326 terminals function with individual SCXI modules.

Table 1. TBX-1326 Terminal Use with SCXI Modules

SCXI Module	TBX-1326 Terminals Used and Their Functions	Unused Terminals
SCXI-1162	V_{cc} —Power/reference voltage CH(X)—Digital input	GND
SCXI-1162HV	GND—Ground reference CH(X)—Input signal	V_{cc}
SCXI-1163	V_{cc} —Power supply GND—Ground CH(X)—Digital output	This module uses all terminals.
SCXI-1163R	GND—Common pole CH(X)—Relay input	V_{cc}

Conventions

The following conventions are used in this guide:



This icon denotes a note, which alerts you to important information.



This icon denotes a caution, which advises you of precautions to take to avoid injury, data loss, or a system crash. When this symbol is marked on the product, see the *Safety Information* section for precautions to take.

bold

Bold text denotes items that you must select or click on in the software, such as menu items and dialog box options. Bold text also denotes parameter names.

italic

Italic text denotes variables, emphasis, a cross reference, or an introduction to a key concept. This font also denotes text that is a placeholder for a word or value that you must supply.

monospace

Text in this font denotes text or characters that you should enter from the keyboard, sections of code, programming examples, and syntax examples. This font is also used for the proper names of disk drives, paths, directories, programs, subprograms, subroutines, device names, functions, operations, variables, filenames and extensions, and code excerpts.

FCC/Canada Radio Frequency Interference Compliance¹

Determining FCC Class

The Federal Communications Commission (FCC) has rules to protect wireless communications from interference. The FCC places digital electronics into two classes. These classes are known as Class A (for use in industrial-commercial locations only) or Class B (for use in residential or commercial locations). Depending on where it is operated, this product could be subject to restrictions in the FCC rules. In Canada, the Department of Communications (DOC), of Industry Canada, regulates wireless interference in much the same way.

Digital electronics emit weak signals during normal operation that can affect radio, television, or other wireless products. By examining the product you purchased, you can determine the FCC Class and therefore which of the two FCC/DOC Warnings apply in the following sections. Some products may not be labeled at all for FCC; if so, the reader should then assume these are Class A devices.

¹ Certain exemptions may apply in the USA, see FCC Rules §15.103 Exempted devices, and §15.105(c). Also available in sections of CFR 47.

FCC Class A products only display a simple warning statement of one paragraph in length regarding interference and undesired operation. Most of our products are FCC Class A. The FCC rules have restrictions regarding the locations where FCC Class A products can be operated.

FCC Class B products display either a FCC ID code, starting with the letters **EXN**, or the FCC Class B compliance mark that appears as shown below.

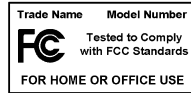

Consult the FCC Web site at fcc.gov for more information.

FCC/DOC Warnings

This equipment generates and uses radio frequency energy and, if not installed and used in strict accordance with the instructions in this manual and the CE Mark Declaration of Conformity,¹ may cause interference to radio and television reception. Classification requirements are the same for the FCC and the DOC.

Changes or modifications not expressly approved by NI could void the user's authority to operate the equipment under the FCC Rules.

Class A

Federal Communications Commission

This equipment has been tested and found to comply with the limits for a Class A digital device, pursuant to part 15 of the FCC Rules. These limits are designed to provide reasonable protection against harmful interference when the equipment is operated in a commercial environment. This equipment generates, uses, and can radiate radio frequency energy and, if not installed and used in accordance with the instruction manual, may cause harmful interference to radio communications. Operation of this equipment in a residential area is likely to cause harmful interference in which case the user will be required to correct the interference at his own expense.

¹ The CE Mark Declaration of Conformity contains important supplementary information and instructions for the user or installer.

Canadian Department of Communications

This Class A digital apparatus meets all requirements of the Canadian Interference-Causing Equipment Regulations.

Cet appareil numérique de la classe A respecte toutes les exigences du Règlement sur le matériel brouilleur du Canada.

Class B

Federal Communications Commission

This equipment has been tested and found to comply with the limits for a Class B digital device, pursuant to part 15 of the FCC Rules. These limits are designed to provide reasonable protection against harmful interference in a residential installation. This equipment generates, uses, and can radiate radio frequency energy and, if not installed and used in accordance with the instructions, may cause harmful interference to radio communications.

However, there is no guarantee that interference will not occur in a particular installation. If this equipment does cause harmful interference to radio or television reception, which can be determined by turning the equipment off and on, the user is encouraged to try to correct the interference by one or more of the following measures:

- Reorient or relocate the receiving antenna.
- Increase the separation between the equipment and receiver.
- Connect the equipment into an outlet on a circuit different from that to which the receiver is connected.
- Consult the dealer or an experienced radio/TV technician for help.

Canadian Department of Communications

This Class B digital apparatus meets all requirements of the Canadian Interference-Causing Equipment Regulations.

Cet appareil numérique de la classe B respecte toutes les exigences du Règlement sur le matériel brouilleur du Canada.

Compliance to EU Directives

Readers in the European Union (EU) must refer to the Manufacturer's Declaration of Conformity (DoC) for information¹ pertaining to the CE Mark compliance scheme. The Manufacturer includes a DoC for most

¹ The CE Mark Declaration of Conformity contains important supplementary information and instructions for the user or installer.

every hardware product except for those bought for OEMs, if also available from an original manufacturer that also markets in the EU, or where compliance is not required as for electrically benign apparatus or cables.

To obtain the DoC for this product, click **Declaration of Conformity** at ni.com/hardref.nsf. This Web site lists the DoCs by product family. Select the appropriate product family, followed by the product, and a link to the DoC appears in Adobe Acrobat format. Click the Acrobat icon to download or read the DoC.

Safety Information

The following section contains important safety information that you *must* follow when installing and using the product.

Do *not* operate the product in a manner not specified in this document. Misuse of the product can result in a hazard. You can compromise the safety protection built into the product if the product is damaged in any way. If the product is damaged, return it to NI for repair.

Do *not* substitute parts or modify the product except as described in this guide.

Do *not* operate the product in an explosive atmosphere or where there may be flammable gases or fumes. Operate the product only at or below the pollution degree stated in the *Specifications* section. Pollution is foreign matter in a solid, liquid, or gaseous state that can reduce dielectric strength or surface resistivity. The following is a description of pollution degrees:

- Pollution degree 1 means no pollution or only dry, nonconductive pollution occurs. The pollution has no influence.
- Pollution degree 2 means that only nonconductive pollution occurs in most cases. Occasionally, however, a temporary conductivity caused by condensation must be expected.
- Pollution degree 3 means that conductive pollution occurs, or dry, nonconductive pollution occurs that becomes conductive due to condensation.

Clean the product with a soft nonmetallic brush. Make sure the product is completely dry and free from contaminants before returning it to service.

You *must* insulate signal connections for the maximum voltage for which the product is rated. Do *not* exceed the maximum ratings for the product. Remove power from signal lines before connecting them to or disconnecting them from the product.

Operate this product only at or below the installation category stated in the *Specifications* section.

The following is a description of installation categories:

- Installation category I is for measurements performed on circuits not directly connected to MAINS¹. This category is a signal level such as voltages on a printed wire board (PWB) on the secondary of an isolation transformer.

Examples of installation category I are measurements on circuits not derived from MAINS and specially protected (internal) MAINS-derived circuits.

- Installation category II is for measurements performed on circuits directly connected to the low-voltage installation. This category refers to local-level distribution such as that provided by a standard wall outlet.

Examples of installation category II are measurements on household appliances, portable tools, and similar equipment.

- Installation category III is for measurements performed in the building installation. This category is a distribution level referring to hardwired equipment that does not rely on standard building insulation.

Examples of installation category III include measurements on distribution circuits and circuit breakers. Other examples of installation category III are wiring including cables, bus-bars, junction boxes, switches, socket outlets in the building/fixed installation, and equipment for industrial use, such as stationary motors with a permanent connection to the building/fixed installation.

- Installation category IV is for measurements performed at the source of the low-voltage (<1,000 V) installation.

Examples of category IV are electric meters and measurements on primary overcurrent protection devices and ripple-control units.

¹ MAINS is defined as the electricity supply system to which the equipment concerned is designed to be connected either for powering the equipment or for measurement purposes.

Below is a diagram of a sample installation.

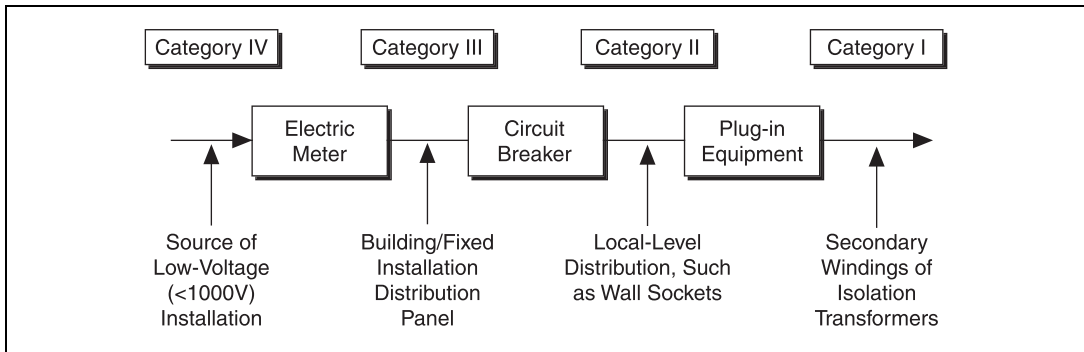

What You Need to Get Started

To install and use the TBX-1326, you need the following items:

- TBX-1326 high-voltage terminal block
- [TBX-1326 High-Voltage Terminal Plug Installation Guide](#)
- 1/8 in. flathead screwdriver
- SCXI chassis
- SCXI-1162/HV, SCXI-1163, or SCXI-1163R module and corresponding documentation
- SH48-48-B cable assembly
- Number 1 Phillips screwdriver

Installing the TBX-1326

Perform the following steps to mount the SH48-48-B cable assembly and connect the TBX-1326 to the SCXI module. Refer to Figures 1 and 2 as needed.



Caution Refer to the *Connecting Signals* section before connecting the signals. If signal wires are connected to the terminal block, dangerous voltages can exist even when the equipment is powered off.

1. Turn off the SCXI chassis.
2. Turn off the computer that contains the E Series data acquisition (DAQ) device or disconnect the device from the SCXI chassis.
3. Connect the TBX cable adapter to the appropriate SCXI module and secure it by tightening both thumb screws as shown in Figure 1.

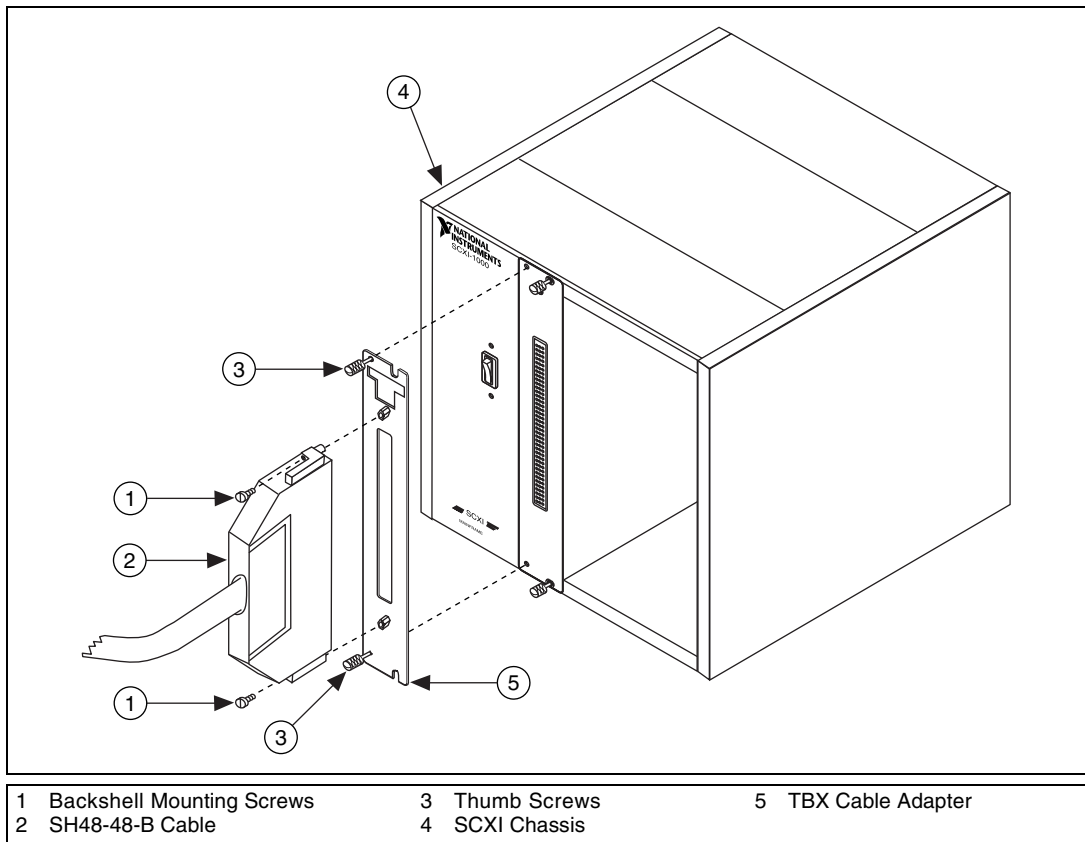

Figure 1. Connecting the SH48-48-B Cable to the SCXI Module

4. Connect the other end of the cable assembly to the TBX-1326 terminal block connector and secure the SH48-48-B cable by tightening both backshell mounting screws. Refer to Figure 2.

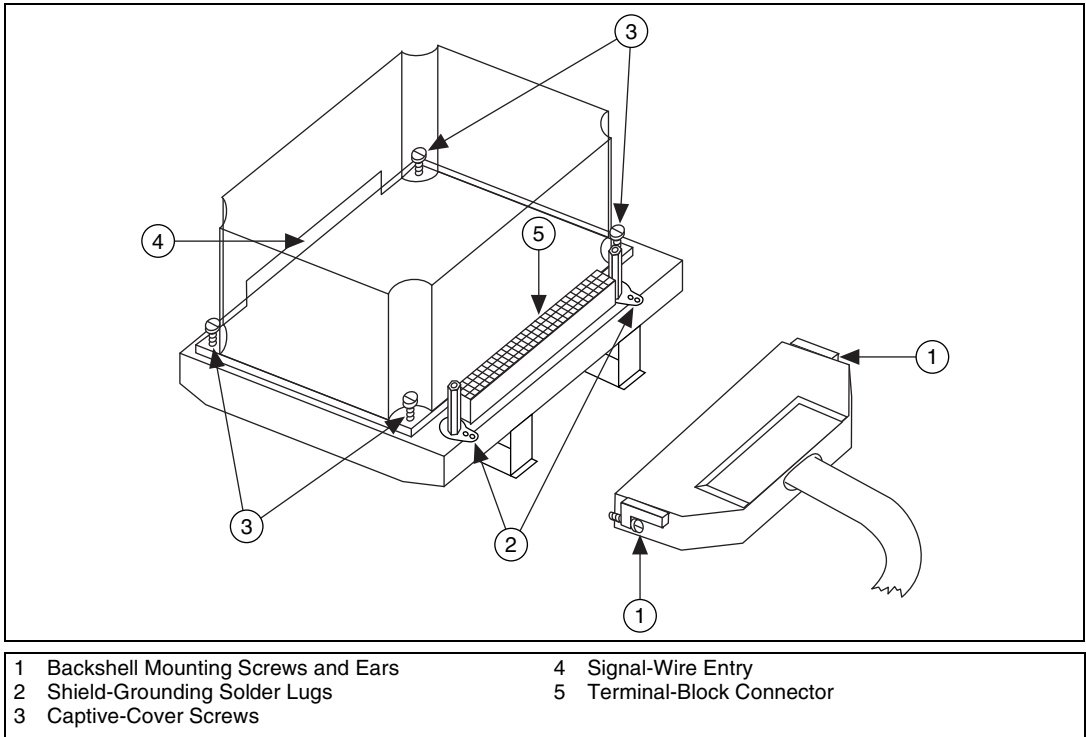

Figure 2. Connecting the SH48-48-B Cable to the TBX-1326 Terminal Block



Note In Figure 2, the SH48-48-B cable is not shown in the exact position for proper connection to the terminal block connector. Refer to Figure 3 for the completed installation.

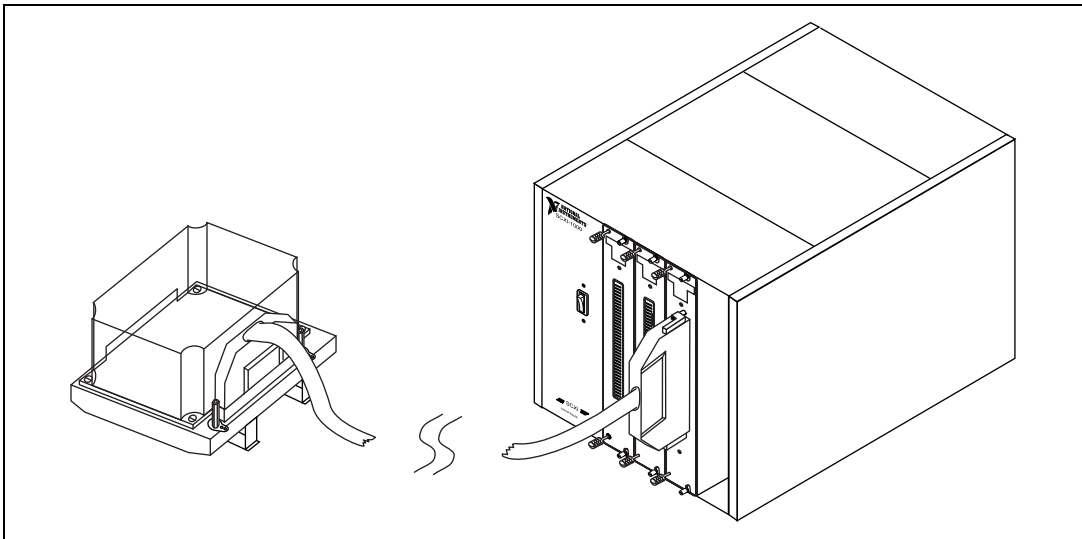

Figure 3. The Completed Installation

Rack Mounting

When you have completed the installation instructions, you are ready to mount the TBX assembly on the rack. If you are using the National Instruments TBX Rack-Mount Assembly, refer to the *TBX Rack-Mount Kit Installation Guide* for instructions. If you are not using this rack-mount assembly, perform the following steps to mount the TBX assembly directly onto the DIN rail:

1. Snap the TBX terminal block onto the DIN rail with a firm push.
2. Install the SCXI chassis using the appropriate chassis rack-mount kit.



Note To remove the TBX terminal block from the DIN rail, place a flathead screwdriver into the slot above the terminal block base and pry it from the rail.

Connecting Signals



Caution Only qualified personnel aware of the dangers involved should use the TBX-1326. If signal wires are connected to the terminal block, dangerous voltage levels can exist even when the equipment is powered off. Before you remove or work with any installed terminal block, disconnect the AC power line or any high-voltage sources ($>30 V_{\text{rms}}$ and $42.4 V_{\text{peak}}$, or 60 VDC) that are connected to the terminal block. NI is *not* liable for any damage or injuries due to misuse of high-voltage signals connected to the terminal block.

When using the terminal block with high voltage levels, you must insulate all signal wires to the highest voltage with which the terminal block comes in contact. NI is *not* liable for any damage or injuries resulting from inadequate signal wire insulation.

The operating common-mode voltage must *not* exceed 250 V_{rms} between banks or from any bank to earth.

Wiring Instructions

To connect the field signals to the TBX-1326 terminal block, refer to Figures 2 and 4 as you perform the following steps:

1. Remove the TBX-1326 terminal block cover by unscrewing the four captive cover screws in the cover corners. These screws stay attached to the cover without falling out.

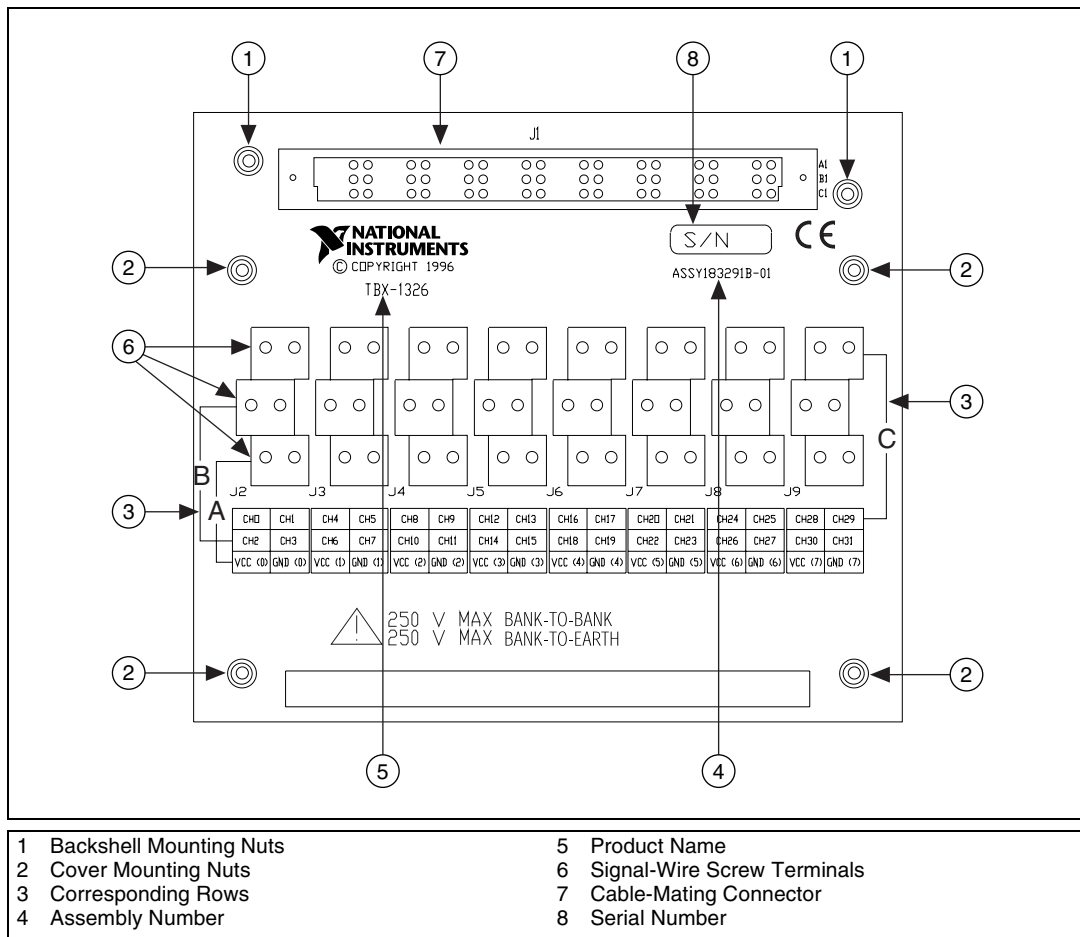

Figure 4. TBX-1326 Parts Locator Diagram

2. Connect the signal wires to the screw terminals. Make sure to connect a V_{cc} and a GND to every bank in use if required to do so by the SCXI module.



Note The TBX-1326 has corresponding rows labeled A, B, and C to help you make the correct signal connections, as shown in Figure 4.

3. Refer to the SCXI module user manual for examples of how to connect field signals and loads. Allow the signal wires to exit through the terminal block cover opening.
4. Replace the TBX-1326 terminal block cover and tighten the captive cover screws.



Note This terminal block does not provide strain relief for field signal wires. If necessary, add strain relief, insulation, and padding for the field signal wires.

The installation and signal connection are now complete.

Specifications

All specifications are typical at 25 °C unless otherwise specified.

Electrical

Common-mode isolation250 V_{rms} between banks, and
bank to earth

Physical

Compatible DIN rails.....DIN EN 50 022
DIN EN 50 035

Terminal block dimensions12.7 × 7.62 × 11.18 cm
(5 × 3 × 4.4 in.)

Maximum Working Voltage

Maximum working voltage refers to the signal voltage plus the common-mode voltage.

Channel-to-earth..... ±250 V, installation category II

Channel-to-channel ±250 V, installation category II



Caution Do *not* exceed the maximum rated voltage of any module when using the terminal block.

Environmental

Operating temperature..... 0 to 50 °C

Storage temperature -20 to 70 °C

Humidity 10 to 90% RH, noncondensing

Maximum altitude 2000 m

Pollution degree (indoor use only)..... 2

Safety

The SCC-A10 meets the requirements of the following standards for safety and electrical equipment for measurement, control, and laboratory use:

- EN 61010-1:1993/A2:1995, IEC 61010-1:1990/A2:1995
- UL 3111-1:1994
- CAN/CSA c22.2 no. 1010.1:1992/A2:1997

Electromagnetic Compatibility

CE, C-Tick, and FCC Part 15 (Class A) Compliant

Electrical emissionsEN 55011 Class A at 10 m
FCC Part 15A above 1 GHz

Electrical immunityEvaluated to EN 61326:1997/
A1:1998, Table 1



Note For full EMC compliance, you must operate this device with shielded cabling. In addition, all covers and filler panels must be installed. Refer to the DoC for this product for any additional regulatory compliance information. To obtain the DoC for this product, click **Declaration of Conformity** at ni.com/hardref.nsf/. This Web site lists the DoCs by product family. Select the appropriate product family, followed by the product, and a link to the DoC appears in Adobe Acrobat format. Click the Acrobat icon to download or read the DoC.

Technical Support Resources

NI Web Support

NI Web support is your first stop for help in solving installation, configuration, and application problems and questions. Online problem-solving and diagnostic resources include frequently asked questions, knowledge bases, product-specific troubleshooting wizards, manuals, drivers, software updates, and more. Web support is available through the Technical Support section of ni.com.

Worldwide Support

NI has offices located around the world to help address your support needs. You can access our branch office Web sites from the Worldwide Offices section of ni.com. Branch office Web sites provide up-to-date contact information, support phone numbers, e-mail addresses, and current events.

If you have searched the technical support resources on our Web site and still cannot find the answers you need, contact the local office or NI corporate. For telephone support in the United States, dial 512 795 8248. For telephone support outside the United States, contact your local branch office:

Australia 03 9879 5166, Austria 0662 45 79 90 0, Belgium 02 757 00 20, Brazil 011 284 5011, Canada (Calgary) 403 274 9391, Canada (Montreal) 514 288 5722, Canada (Ottawa) 613 233 5949, Canada (Québec) 514 694 8521, Canada (Toronto) 905 785 0085, China (Shanghai) 021 6555 7838, China (ShenZhen) 0755 3904939, Czech Republic 02 2423 5774, Denmark 45 76 26 00, Finland 09 725 725 11, France 01 48 14 24 24, Germany 089 741 31 30, Greece 30 1 42 96 427, Hong Kong 2645 3186, India 91805275406, Israel 03 6120092, Italy 02 413091, Japan 03 5472 2970, Korea 02 596 7456, Malaysia 603 9596711, Mexico 001 800 010 0793, Netherlands 0348 433466, New Zealand 09 914 0488, Norway 32 27 73 00, Poland 0 22 3390 150, Portugal 351 1 726 9011, Russia 095 2387139, Singapore 2265886, Slovenia 386 3 425 4200, South Africa 11 805 8197, Spain 91 640 0085, Sweden 08 587 895 00, Switzerland 056 200 51 51, Taiwan 02 2528 7227, United Kingdom 01635 523545