

SCXI-1341 LAB/1200 SERIES CABLE ASSEMBLY

This guide describes how to install the SCXI-1341 Lab/1200 Series cable assembly between an SCXI module and a DAQ board.

Introduction

With the SCXI-1341 Lab/1200 Series cable assembly, you can connect your Lab/1200 Series DAQ board to an SCXI module. If you have a newly released module that is not included in the list below, contact National Instruments for cable information.

The SCXI-1341 cable assembly consists of a 50-conductor NB1 ribbon cable and an adapter board. The ribbon cable connects the I/O connector of the Lab/1200 Series board to the adapter board rear connector. The adapter board also has a female right-angle module connector that plugs into the rear of the SCXI module. In addition, the adapter board has an extra male breakout connector for the unmodified signals of the Lab/1200 Series board you can use with other accessories. You can connect an SCXI-1180 to this male breakout connector to bring the Lab/1200 Series board pinout to the front of your SCXI chassis.

What You Need to Get Started

- An SCXI chassis
- One of the following SCXI modules:
 - SCXI-1100
 - SCXI-1102
 - SCXI-112x
 - SCXI-114x
 - SCXI-116x
 - SCXI-1181

SCXI™ is a trademark of National Instruments Corporation. Product and company names are trademarks or trade names of their respective companies.

- ❑ A computer
- ❑ One of the following Lab/1200 Series DAQ boards:
 - PCI-1200
 - Lab-PC-1200
 - Lab-PC-1200AI
 - Lab-PC
 - Lab-PC+
 - Lab-NB
- ❑ A small flathead screwdriver
- ❑ 1.0 m NB1 cable
- ❑ Two small screws
- ❑ Adapter board
- ❑ *SCXI-1341 Lab/1200 Series Cable Assembly Installation Guide*

Installation Procedure

Figure 1 illustrates the components of your SCXI system.

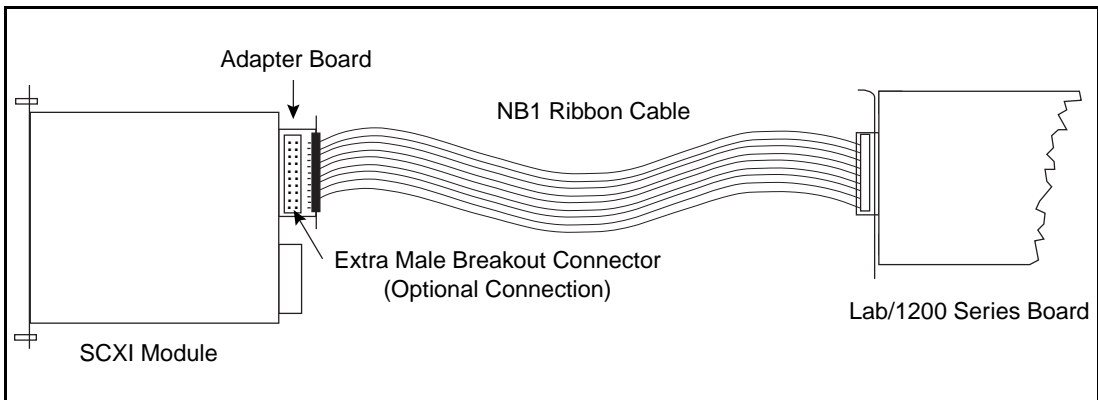

Figure 1. Connecting the SCXI-1341 to Your DAQ Board and SCXI Module

Perform the following steps to install the SCXI-1341 cable:

1. Turn off the power to your computer and the SCXI chassis.
2. Install your SCXI module in the SCXI chassis, following the instructions in your module user manual.

- Set jumper W1 on the SCXI-1341 adapter board to the correct position for your system, as shown in Figure 2. When set to position A, the factory-default position, jumper W1 connects pin 43 of the Lab/1200 Series board to pin 46 of the module connector. Position B breaks this connection. Leave jumper W1 in position A unless you are using an SCXI-1140 module and are not supplying the HOLDTRIG signal to the module from the Lab/1200 Series board. See your *SCXI-1140 User Manual* for an explanation of the HOLDTRIG signal.

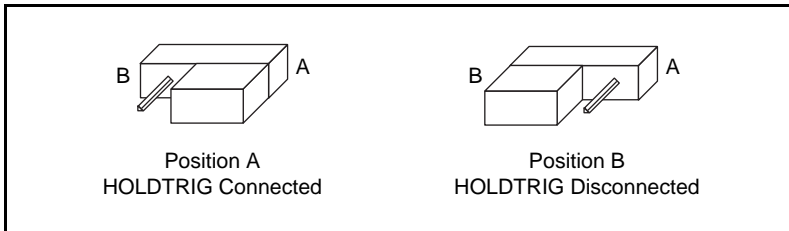

Figure 2. Jumper W1 Settings

- Plug the female right-angle module connector of the SCXI-1341 adapter board into the rear signal connector of the SCXI module.
- Secure the SCXI-1341 adapter board by screwing the two screws through the rear panel of the adapter board and into the threaded strips in the rear of the SCXI chassis.
- Install your DAQ board in a slot in your computer, following the instructions in your DAQ board user manual.
- Connect one end of the NB1 cable to the rear connector of the adapter board.
- Connect the loose end of the NB1 cable to the I/O connector on the DAQ board as shown in Figure 3.

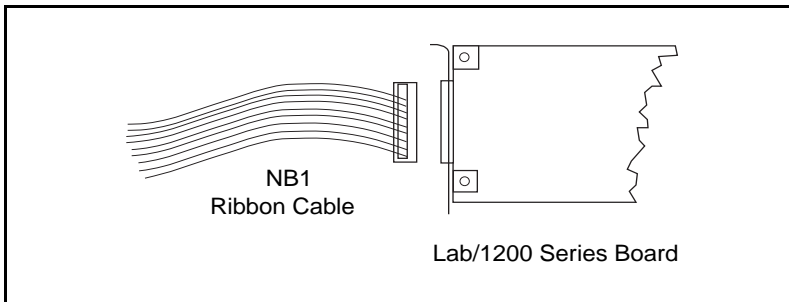

Figure 3. Cable to I/O Connector Connection

The finished installation should look like Figure 4.

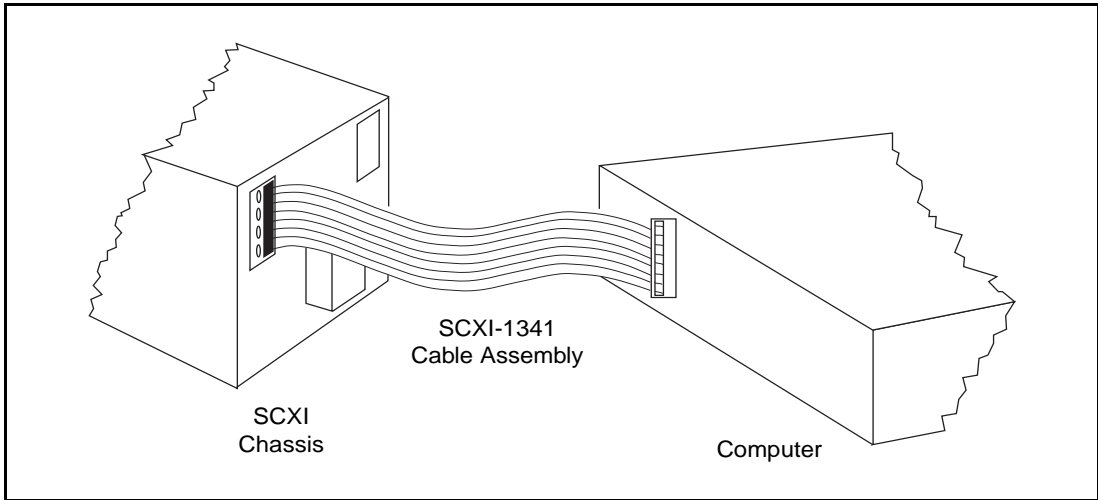

Figure 4. Installed Cable

SCXI-1341 Pin Equivalencies

The following table lists the SCXI-1341 pin equivalencies for a Lab/1200 Series board and an SCXI module.

Table 1. SCXI-1341 Pin Equivalencies

Rear Connector Pin	Lab/1200 Series Signal Name	Male Breakout Connector Pin	Module Connector Pin
1	ACH0	1	3
2	ACH1	2	5
3	ACH2	3	7
4	ACH3	4	9
5	ACH4	5	11
6	ACH5	6	13
7	ACH6	7	15
8	ACH7	8	17
9	AIGND/AISENSE ¹	9	1, 2
10	DAC0OUT ²	10	20
11	AGND ³	11	23
12	DAC1OUT ²	12	21
13	DGND	13	24, 33
14	PA0	14	Not connected
15	PA1	15	Not connected
16	PA2	16	Not connected
17	PA3	17	Not connected
18	PA4	18	Not connected
19	PA5	19	Not connected
20	PA6	20	Not connected
21	PA7	21	Not connected
22	PB0	22	Not connected
23	PB1	23	Not connected
24	PB2	24	Not connected
25	PB3	25	Not connected

Table 1. SCXI-1341 Pin Equivalencies (Continued)

Rear Connector Pin	Lab/1200 Series Signal Name	Male Breakout Connector Pin	Module Connector Pin
26	PB4	26	25
27	PB5	27	27
28	PB6	28	29
29	PB7	29	37
30	PC0	30	Not connected
31	PC1	31	26
32	PC2	32	28
33	PC3	33	Not connected
34	PC4	34	Not connected
35	PC5	35	Not connected
36	PC6	36	Not connected
37	PC7	37	Not connected
38	EXTTRIG	38	Not connected
39	EXTUPDATE* ²	39	Not connected
40	EXTCONV*	40	36
41	OUTB0	41	Not connected
42	GATB0	42	Not connected
43	OUTB1	43	46
44	GATB1	44	Not connected
45	CLKB1	45	Not connected
46	OUTB2	46	Not connected
47	GATB2	47	Not connected
48	CLKB2	48	Not connected
49	+5V	49	34, 35
50	DGND	50	24, 33

¹ AIGND on the Lab-NB and Lab-PC.

² Not connected on the Lab-PC-1200AI.

³ AOGND on the Lab-NB and Lab-PC.