

GETTING STARTED GUIDE

NI High-Speed Digitizers

This document explains how to install, configure, and test NI high-speed digitizers, and how to begin programming using the NI-SCOPE driver software. This document applies to the NI 5102, NI 5112, NI 5114, NI 5122, NI 5124, NI 5620, NI 5621, NI 5911, and NI 5922 digitizers.

For more information on features and programming, refer to the *NI High-Speed Digitizers Help* at **Start»Programs»National Instruments»NI-SCOPE»Documentation»NI High Speed Digitizers Help**.

For NI high-speed digitizer specifications, refer to the specifications document included with your digitizer.

For the most current versions of documentation, visit ni.com/manuals.

For the latest version of NI-SCOPE, visit ni.com/idnet.



Contents

Conventions	2
1. Verifying System Requirements	3
Minimum System Requirements	3
Recommended System	3
Application Development Environments.....	4
2. Unpacking	4
3. Verifying the Kit Contents.....	4
Other Required Items	5
For PXI Devices.....	5
For PCI Devices	5
4. Installing the Software	6
5. Installing the Hardware.....	6
PXI Devices	6
PCI Devices	8
PCMCIA Devices	10
USB Devices.....	11
6. Configuring and Testing in MAX.....	12
Acquiring Data Interactively	14
Acquiring Data Programmatically	14

7. Making Your First Measurement.....	14
Appendix A: Front Panels.....	15
NI 5102 Front Panels	15
NI 5112 Front Panels	20
NI 5114 Front Panel.....	21
NI 5122/5124 Front Panels	23
NI 5620/5621 Front Panels	25
NI 5911 Front Panel.....	26
NI 5922 Front Panels	27
Appendix B: Troubleshooting	28
Device Front Panel ACCESS LED on PXI Module is Off	
When PXI Chassis is On.....	28
Device Does Not Appear in MAX.....	29
Device Failed the Self-Test.....	29
Thermal Shutdown Error	29
Performance Issues Using MXI Connections.....	29
Setting Up NI-DAQmx Devices for Synchronization	30
Appendix C: Where to Go for Support.....	31

Conventions

The following conventions are used in this manual:

- » The » symbol leads you through nested menu items and dialog box options to a final action. The sequence **File» Page Setup»Options** directs you to pull down the **File** menu, select the **Page Setup** item, and select **Options** from the last dialog box.
- ◆ The ◆ symbol indicates that the following text applies only to a specific product, a specific operating system, or a specific software version.
-  This icon denotes a tip, which alerts you to advisory information.
-  This icon denotes a note, which alerts you to important information.
-  This icon denotes a caution, which advises you of precautions to take to avoid injury, data loss, or a system crash.
- bold** Bold text denotes items that you must select or click in the software, such as menu items and dialog box options.
- italic* Italic text denotes emphasis or a cross reference.

<code>monospace</code>	Text in this font denotes text or characters that you should enter from the keyboard, sections of code, programming examples, and syntax examples. This font is also used for disk drives, paths, directories, filenames, and extensions.
monospace bold	Bold text in this font denotes the messages and responses that the computer automatically prints to the screen. This font also emphasizes lines of code that are different from the other examples.
<i>monospace italic</i>	Italic text in this font denotes text that is a placeholder for a word or value that you must supply.

1. Verifying System Requirements

To use an NI high-speed digitizer with NI-SCOPE, your system must meet the listed *Minimum System Requirements* and must have one of the listed operating systems installed. For optimal performance, your system should meet the *Recommended System Requirements*. If you are developing applications, you need one of the listed [Application Development Environments](#) (ADEs) and its documentation.

Minimum System Requirements

- Processor: Pentium 200 MHz or equivalent
- RAM: 64 MB
- Microsoft Internet Explorer 5.5 or later
- Screen resolution of 1024 × 768 with 256 colors—required for Scope Soft Front Panel (SFP)

Recommended System

- Processor: Pentium III/Celeron 600 MHz or equivalent
- RAM: 256 MB
- Microsoft Internet Explorer 5.5 or later
- Screen resolution of 640 × 480 with 256 colors
- Windows 2000/XP with all available critical updates and service packs installed

Application Development Environments

- LabVIEW 7.0 or later (LabVIEW 7.1 or later is required to use the NI-SCOPE Express VI)
- LabVIEW Real-Time Module 7.1 or later (NI 5114/5122/5124/5922)
- LabWindows™/CVI™ 6.0 or later
- Measurement Studio 6.0 or later
- Microsoft Visual C++ (MSVC) 6.0 or later
- Microsoft Visual Basic 6.0



Note If you use the Scope SFP to interactively control the digitizer, an ADE is not required. The Scope SFP is included on the NI-SCOPE CD.

2. Unpacking

NI high-speed digitizers are shipped in an antistatic bag to protect them from electrostatic discharge (ESD). Prior to removing the digitizer from the bag, touch the antistatic bag to a metal part of the chassis to remove any built up static charge.



Caution When handling the digitizer, ensure that you are grounded with a grounding strap or touching a grounded metal object. Handle the digitizer carefully to avoid touching any exposed pins or electronic circuitry.

Remove the digitizer from the package, remove the packing foam and rubber screw covers (PXI devices only), and inspect the digitizer for loose components or any sign of damage. Notify NI if the digitizer appears damaged in any way. Do *not* install a damaged digitizer into your computer or chassis.

Store the digitizer in the antistatic bag when not in use.

3. Verifying the Kit Contents

The following items are included in the NI high-speed digitizer kit:

- One of the following NI high-speed digitizers:
 - NI PXI/PCI/USB/PCMCIA-5102
 - NI PXI/PCI-5112
 - NI PXI-5114
 - NI PXI/PCI-5122/5124

- NI PXI-5620/5621
- NI PCI-5911
- NI PXI/PCI-5922

NI-SCOPE instrument driver DVD-sized case, which contains the following:

- NI-SCOPE driver software CD
- *NI-SCOPE Instrument Driver Quick Reference*
- *NI High-Speed Digitizers Getting Started Guide*

Other included items:

- The specifications document for the digitizer
- *Read Me First: Safety and Radio-Frequency Interference*
- (NI 5114/5122/5124/5922 only)—*Maintain Forced-Air Cooling Note to Users*
- (NI 5114/5122/5124/5922: memory options higher than 8 MB only)—NI Spectral Measurements Toolkit CD

Other Required Items

In addition to the items contained in the kit, you need the following items:

1/8 in. flat-head screwdriver

For PXI Devices

A PXI chassis, a PXI/SCXI combination chassis, or a PXI/CompactPCI chassis—with a controller and the chassis documentation



Note If your application uses NI-TClk synchronization, you *must* use a PXI chassis. Refer to **NI High-Speed Digitizers Help»NI-TClk Synchronization Help** for more information.

For PCI Devices

A desktop computer and its documentation

4. Installing the Software



Caution Make sure you install the software *before* you install the hardware.

To install the software, complete the following steps:

1. If you are using an ADE such as LabVIEW or if you are using a third-party tool, install it now. You *must* install the ADE before installing NI-SCOPE.
2. Install NI-SCOPE by inserting the NI-SCOPE CD into the CD drive and clicking **Install Software** in the window that appears.



Note If the installation window does not appear automatically, navigate to the CD drive and double-click `setup.exe`.

3. If you are using a system running the LabVIEW Real-Time Module, restart. Download NI-SCOPE to the target using Measurement & Automation Explorer (MAX). For more information, refer to the *Measurement & Automation Explorer Remote Systems Help* by selecting **Help»Help Topics»Remote Systems** in MAX.

5. Installing the Hardware

This section describes how to install hardware for the following platforms: PXI, PCI, PCMCIA, and USB.



Note For all platforms, you must install the software *before* you install the hardware.

To prevent damage to the device caused by ESD or contamination, handle the device using the edges or the metal bracket. Refer to the *Read Me First: Safety and Radio Frequency Interference* for more information.



Caution You *must* power off and unplug your PC or chassis before installing the hardware.

PXI Devices

NI PXI devices are sensitive instruments that should be handled carefully. Do not expose the device to temperatures or humidity beyond the rated maximums. Keep the device free of dust by cleaning with compressed air only. Do not clean the device with any solvents or liquids.

You can install PXI devices in any PXI slot marked with a peripheral slot compatibility glyph (a circle containing the slot number).

To install a PXI device, complete the following steps:

1. Power off and unplug the PXI chassis before installing a PXI device.
2. If the PXI chassis has multiple fan speed settings, ensure that the fans are set to high.
3. Position the PXI chassis so that inlet and outlet vents are not obstructed. For more information, refer to the chassis documentation.
4. Ensure that the ejector handle is in the unlatched (downward) position.
5. Holding the device by the ejector handle, slide it into an empty slot, ensuring that the base card (the card on the left when you look at the front of the device) engages with the card guides in the chassis, as shown in Figure 1.

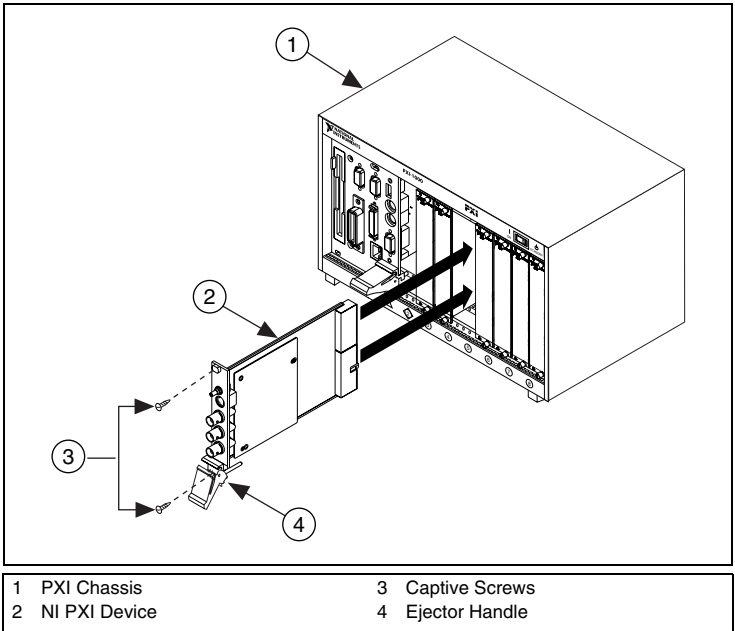

Figure 1. PXI Installation

6. Slide the device completely into the chassis and latch it by pulling up on the ejector handle.
7. Tighten the captive screws at the top and bottom of the device front panel. Performance may suffer if both screws are not tightened properly.
8. Verify that the PXI chassis fans are operable and free of dust and other contaminants restricting airflow.

- Before operating the device, cover all empty PXI slots using PXI filler panels.
- Plug in and power on the PXI chassis.

PCI Devices

To install a PCI device, complete the following steps:

- Power off and unplug the PC.
- Remove the PC cover.
- Insert the device into an open PCI slot, as shown in Figure 2.

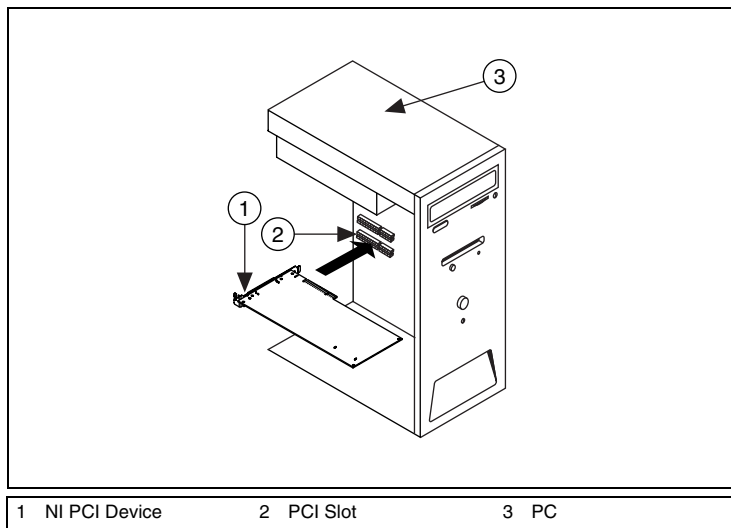

Figure 2. PCI Installation



Tip To maximize airflow and extend the life of the device, leave any adjacent PCI slots empty.

◆ NI PCI-5911

When you install the NI PCI-5911, verify that the BNC connector is centered in the metal frame of the chassis, as shown in Figure 3. Signal degradation can occur if the outer shell of the BNC connector touches the computer chassis. Also, to minimize noise, do *not* allow the shell of the BNC connector to touch or lie near the metal on a PC.

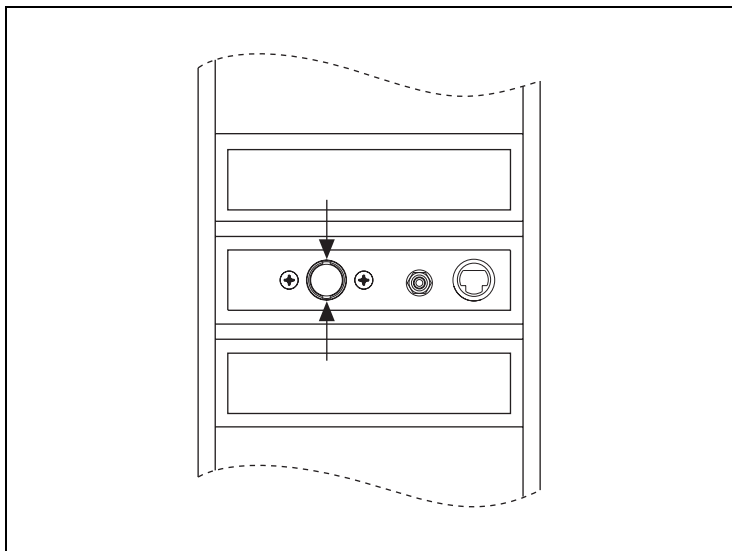

Figure 3. NI 5911 Installation

Multiple NI 5911 devices in the same computer can raise operating temperatures beyond specification and produce imprecise data. NI strongly recommends leaving an empty PCI slot between multiple NI 5911 devices or adding a fan.

4. Secure the device with a screw.



Caution It is important to completely screw the device into the PCI slot both for mechanical stability and to create a solid ground connection. Improperly secured devices may affect the accuracy of device specifications.

(NI PCI-5122/5124/5922 only) Some computer manufacturers use a securing lever made of plastic to secure PCI devices; such a lever is unacceptable and *must* be removed. Use the screw provided in the kit to screw down the NI PCI-5122/5124/5922. Otherwise, you must use a different computer chassis.

5. Replace the PC cover.
6. Plug in and power on the PC.



Caution Spread-spectrum clocking varies the clock signal to spread the timing clock signal over a small frequency range. Disabling spread-spectrum clocking may affect the accuracy of the NI 5122/5124/5922 specifications.

7. (NI PCI-5122/5124/5922 only) Verify that spread-spectrum clocking is enabled in the PC BIOS. Refer to the PC user documentation for information about how to verify this setting.

PCMCIA Devices

To install the NI PCMCIA-5102, complete the following steps:

1. Power off and unplug the laptop.
2. Connect a PSH32-C5 cable to the digitizer.
3. Install the digitizer as shown in Figure 4.
4. Power on your laptop.

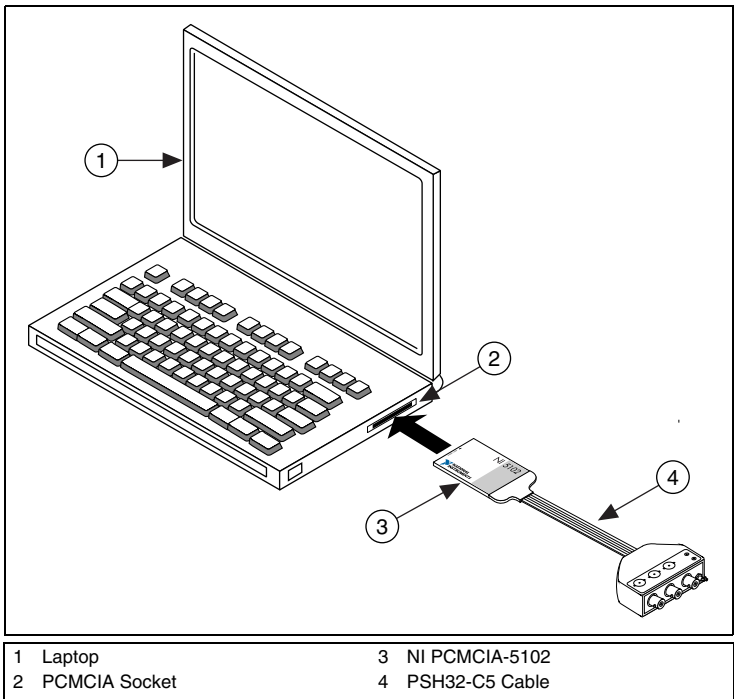
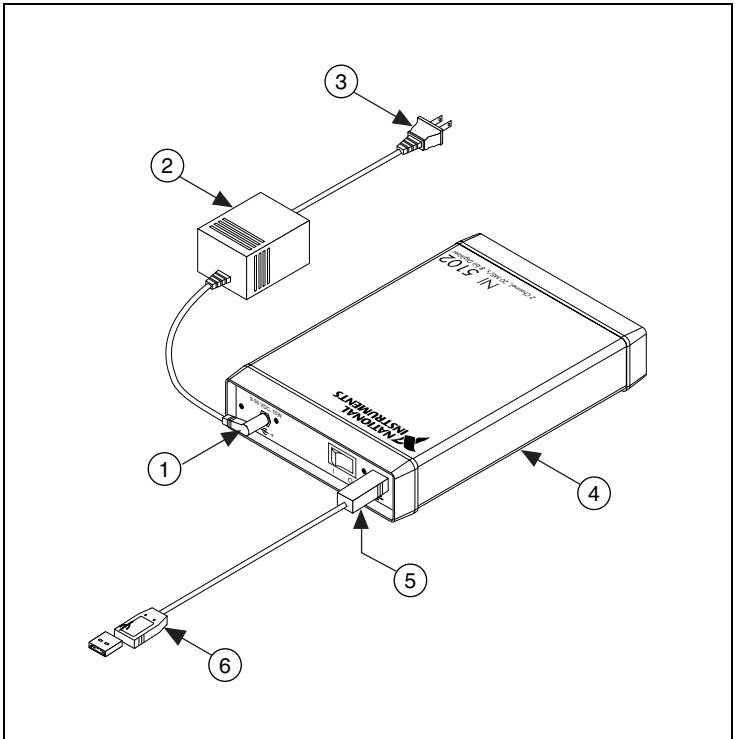

Figure 4. PCMCIA Installation

USB Devices

To install the NI USB-5102, complete the following steps:

1. Connect the USB cable to the PC and the digitizer, as shown in Figure 5.



1 Power Jack	4 NI USB-5102
2 AC/DC Converter	5 USB Connector (Downstream)
3 AC/DC Plug	6 USB Connector to PC (Upstream)

Figure 5. USB Installation

2. Plug the power cord into the power jack on the NI USB-5102.
3. Plug the AC/DC plug on the power cord into the power source.

6. Configuring and Testing in MAX

1. Launch MAX.
2. Expand **Devices and Interfaces** to see the list of installed devices. If you are using a digitizer with the LabVIEW Real-Time Module, expand **Remote Systems**. Find your target IP address or name, expand it, and then expand **Devices and Interfaces**.

The configuration tree lists both Traditional NI-DAQ devices and NI-DAQmx devices, as shown in Figure 6.

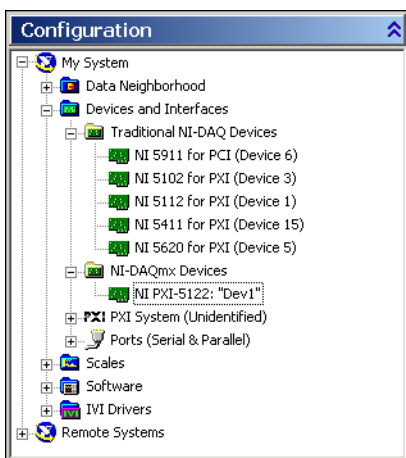

Figure 6. MAX Configuration Tree



Note If your device is not listed, press <F5> to refresh. If the device is still not listed, repeat the steps in section 5. *Installing the Hardware*. For more information about using MAX, refer to the help files available within MAX.



Tip Refer to **Start>Programs>National Instruments>LabVIEW 7.x>Module Documents>Search the Real-Time Module Bookshelf** for more information about using the LabVIEW Real-Time Module.

3. Record the device number or device name assigned by MAX. You need this number when programming your device.

- ◆ **Traditional NI-DAQ (NI 5102/5112/5620/5621/5911)**—Select the device to see its properties in the configuration view. The device number appears in the Value column. By default, the resource name for the device is `DAQ: :n`, where *n* is the device number MAX assigned to your device. Devices configurable under Traditional NI-DAQ are not supported by LabVIEW Real-Time.
- ◆ **NI-DAQmx (NI 5114/5122/5124/5922)**—The assigned device name is appended to the device in its configuration tree label. For example, after you install the NI 5114/5122/5124/5922, the device configuration tree label may appear as `NI PXI-5122: "Dev1"`, where *Dev1* is the device name. When developing your application, the resource name is the device name assigned by MAX. Only the devices that appear under NI-DAQmx are supported by the LabVIEW Real-Time Module.



Note To avoid modifying existing applications that use a Traditional NI-DAQ device number, change the assigned NI-DAQmx device name. To change an NI-DAQmx device name, right-click on the device, select **Rename**, and enter the Traditional NI-DAQ device number used in your application. For more information about device naming conventions, refer to the `niScope_init` function at **NI High-Speed Digitizers Help» Programming»NI-SCOPE Function Reference Help**.

4. Perform a self-test on the device to verify installation.

- ◆ **Traditional NI-DAQ**—Right-click the device, select **Properties**, and click **Test Resources**. Traditional NI-DAQ does not have test panels for LabVIEW Real-Time Series products.
- ◆ **NI-DAQmx**—Right-click the device and select **Self-Test**.

A dialog box appears and indicates whether the device has passed the test.



Note If the device does not pass the test, repeat the instructions in section [5. Installing the Hardware](#). If the device still does not pass the test, visit NI Technical Support at ni.com/support.

5. Run the test panels on the device to verify the signal.

- a. Connect a signal to the digitizer and select the appropriate parameters such as range, input limits, sample rate, and sample mode.

- b. Access the test panel.
 - ◆ **Traditional NI-DAQ**—Click **Run Test Panels** in the Properties window.
 - ◆ **NI-DAQmx**—Right-click the device and select **Test Panels**.



Notes For both types of devices, you can enable triggering by clicking the **Advanced** button on the test panel.

All NI digitizers have self-calibration capabilities. You can access this feature for all NI digitizers programmatically with NI-SCOPE and your ADE, or you can use the Scope SFP. However, only NI 5114/5122/5124/5922 digitizers can be self-calibrated using MAX.

6. Exit MAX when you have finished configuring and testing the device.

Acquiring Data Interactively

Launch the Scope SFP from **Start»Programs»National Instruments»NI-SCOPE»NI-SCOPE Soft Front Panel**. The Scope SFP provides context-sensitive help for using its controls.

Acquiring Data Programmatically

You can use NI-SCOPE to begin programming the digitizer in your ADE. Programming examples for using NI-SCOPE with LabVIEW, CVI, and C are located at **Start»Programs»National Instruments»NI-SCOPE»Examples**.

For more information about programming with NI-SCOPE, refer to the *NI High-Speed Digitizers Help* at **Start»Programs»National Instruments»NI-SCOPE»Documentation**.

7. Making Your First Measurement

To begin making measurements with an NI high-speed digitizer, complete the following steps:

1. Launch your ADE.
2. Navigate to the example programs for your ADE and open one of the examples. If you are not sure which example to choose, begin with the *Getting Started* example.
3. Enter the correct string into the resource name control or parameter. This string varies depending on whether the digitizer is a Traditional NI-DAQ device or an NI-DAQmx device. You can refer to any of the following resources for more information about device names.

- Section 6. *Configuring and Testing in MAX*
 - **NI-SCOPE VI Reference Help»niScope Initialize**
 - **NI-SCOPE C Function Reference Help»niScope_init**
4. Adjust the parameters, if necessary, to capture the input signal that you want to acquire.
 5. Connect the signal that you want to acquire to one of the input channels of the digitizer. Refer to *Appendix A: Front Panels* for the appropriate connection.
 6. Run the example program.

Appendix A: Front Panels

This appendix describes digitizer front panels and signal connections.

NI 5102 Front Panels

The NI 5102 is available for five platforms: PXI, PCI, PCMCIA, and USB. This section describes the front panels and signal connections for each type of NI 5102 digitizer.

- ◆ **NI PXI-5102**—Figure 7 shows the NI PXI-5102 front panel. Refer to Figure 8 for the AUX connector pinout information.

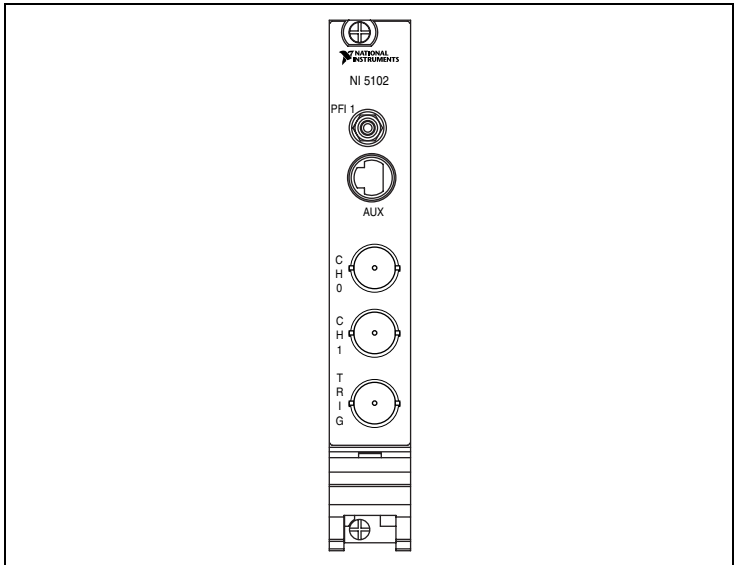

Figure 7. NI PXI-5102 Front Panel

Table 1 describes the signal connections for the NI PXI-5102.

Table 1. NI PXI-5102 Front Panel Signal Connections

Connector	Description	Function
CH 0, CH 1	Standard BNC female connector	Analog input connection; digitizes data and triggers acquisitions.
TRIG	Standard BNC female connector	External analog trigger connection; signals on the TRIG connector cannot be digitized.
PFI 1	Standard SMB jack connector	Multipurpose digital timing and triggering signal.
AUX	9-pin mini-circular DIN connector (Figure 8)	Access to PFI 2 (with optional cable). Refer to Figure 8 for pinout information.

Figure 8 shows the pin assignments for the 9-pin DIN connector on the NI PXI-5102.

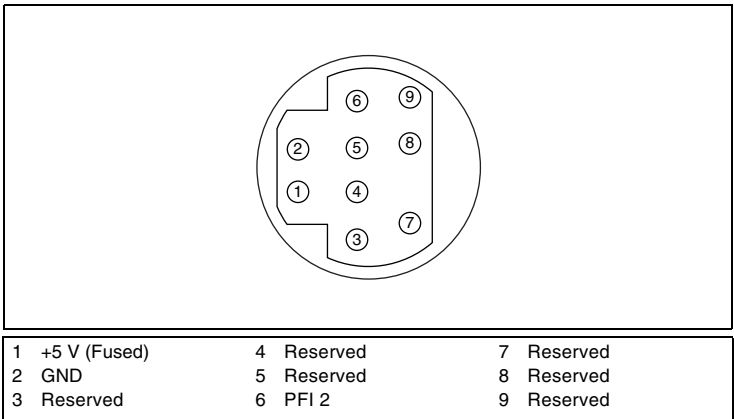

Figure 8. 9-Pin DIN Connector for NI PXI-5102, NI PXI/PCI-5112, and NI PCI-5911



Note The +5 V signal is fused at 1.1 A. However, NI recommends limiting the current from this pin to 30 mA. The fuse is self-resetting.

◆ **NI PCI/AT-5102**—Figure 9 shows the NI PCI-5102 front panel.

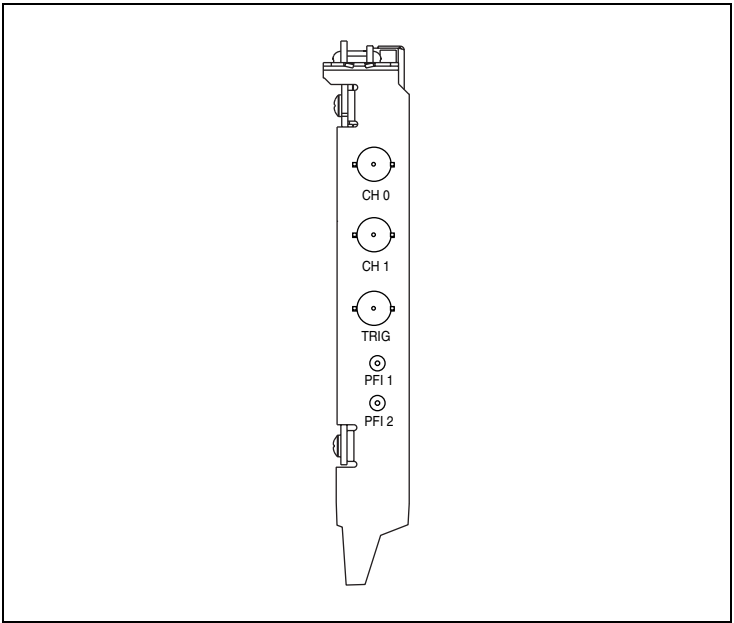

Figure 9. NI PCI-5102 Front Panel

- ◆ **NI PCMCIA-5102**—Figure 10 shows the NI PCMCIA-5102 front panel. Use the cable assembly provided with the digitizer for the connections on the NI PCMCIA-5102.

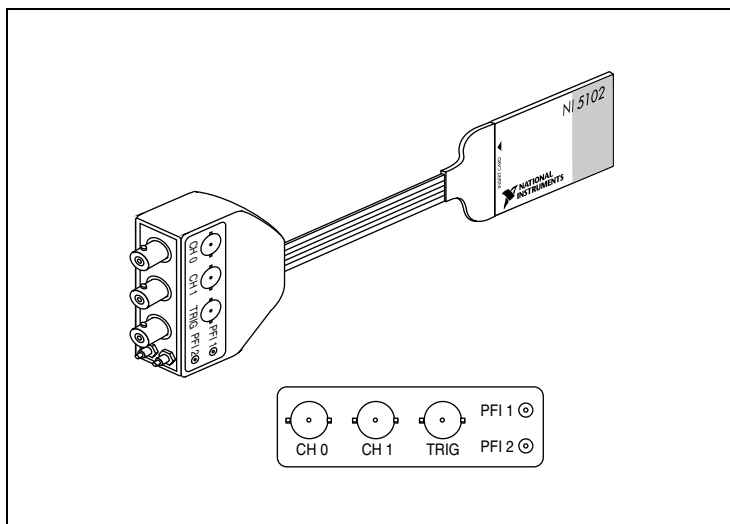

Figure 10. NI PCMCIA-5102 Front Panel

- ◆ **NI USB-5102**—Figure 11 shows the NI USB-5102 front panel.

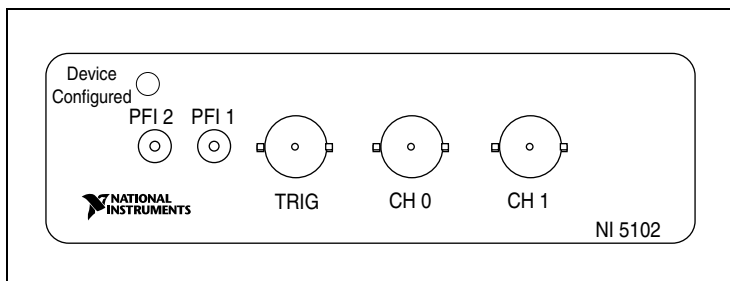

Figure 11. NI USB-5102 Front Panel

Table 2 describes the signal connections for all NI 5102 digitizer buses except PXI.

Table 2. NI PCI/AT/PCMCIA/USB-5102 Front Panel Signal Connections

Connector	Description	Function
CH 0, CH 1	Standard BNC female connector	Analog input connection; digitizes data and triggers acquisitions.
TRIG	Standard BNC female connector	External analog trigger connection; signals on the TRIG connector cannot be digitized.
PFI 1	Standard SMB jack connector	Multipurpose digital timing and triggering signal.
PFI 2	Standard SMB jack connector	Multipurpose digital timing and triggering signal.



Note When used as inputs, NI 5102 PFI lines can trigger an acquisition and/or allow an external sample clock connection.

NI 5112 Front Panels

Figure 12 shows the NI PXI-5112 and the NI PCI-5112 front panels. Refer to Figure 8 for the AUX connector pinout information.

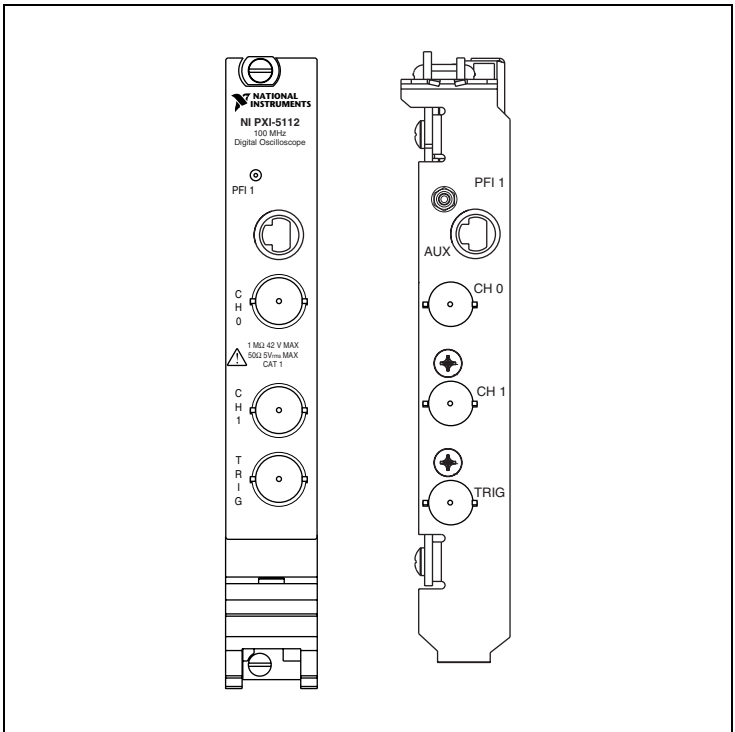

Figure 12. NI PXI/PCI-5112 Front Panels

Table 3 describes the signal connections on the NI PXI/PCI-5112.

Table 3. NI PXI/PCI-5112 Front Panel Signal Connections

Connector	Description	Function
CH 0, CH 1	Standard BNC female connector	Analog input connection; digitizes data and triggers acquisitions.
TRIG	Standard BNC female connector	External analog trigger connection; signals on the TRIG connector cannot be digitized.

Table 3. NI PXI/PCI-5112 Front Panel Signal Connections (Continued)

Connector	Description	Function
PFI 1	Standard SMB jack connector	Multipurpose digital timing and triggering signal.
AUX	9-pin mini-circular DIN connector (Figure 8)	Access to PFI 2 (with optional cable). Refer to Figure 8 for pinout information.

NI 5114 Front Panel

Figure 13 shows the NI PXI-5114 front panel. Refer to Figure 15 for the AUX connector pinout information.

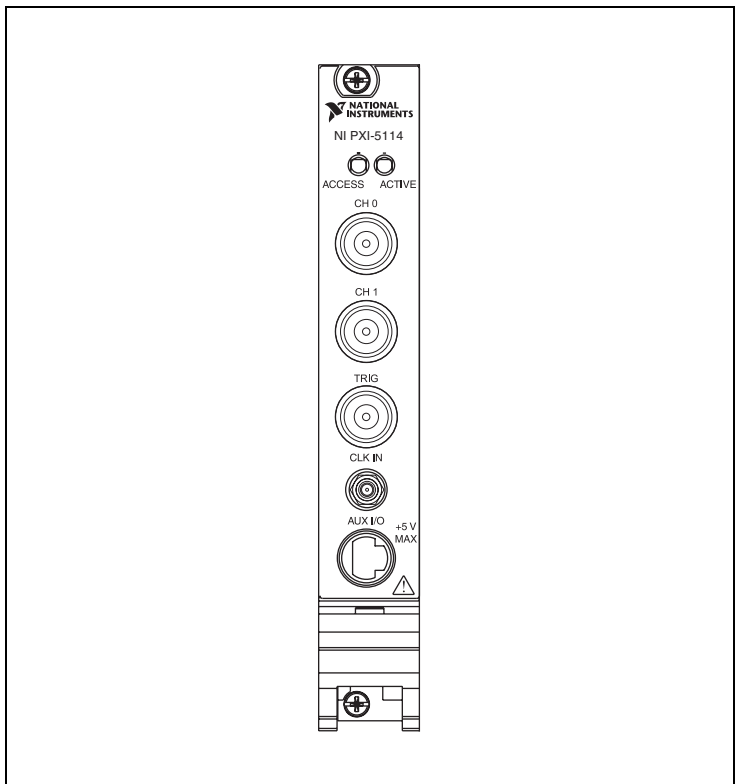

Figure 13. NI PXI-5114 Front Panel

Table 4 describes the signal connections on the NI PXI-5114.

Table 4. NI PXI-5114 Front Panel Signal Connections

Connector	Description	Function
CH 0, CH 1	Standard BNC female connector	Analog input connection; digitizes data and triggers acquisitions.
TRIG	Standard BNC female connector	External analog trigger connection; signals on the TRIG connector cannot be digitized.
CLK IN	Standard SMB jack connector	Input for an external reference or sample clock to the digitizer.
AUX I/O	9-pin mini-circular DIN connector (Figure 15)	Provides access to the multipurpose digital timing and triggering lines, PFI 0, and PFI 1 (with optional cable).

NI 5122/5124 Front Panels

Figure 14 shows the NI PXI-5122/5124 and the NI PCI-5122/5124 front panels. Refer to Figure 15 for the AUX connector pinout information.

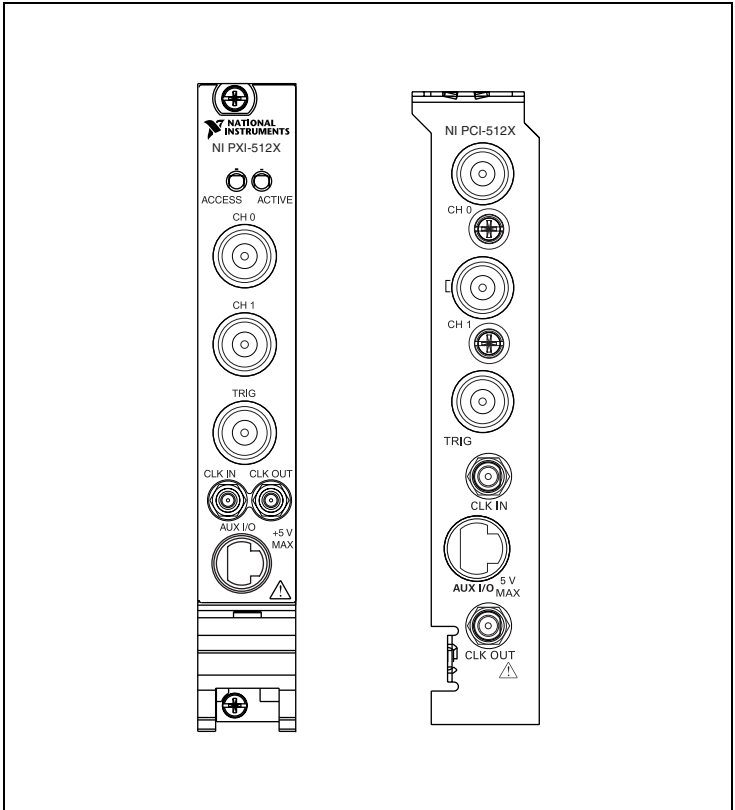

Figure 14. NI PXI/PCI-5122/5124 Front Panels

Table 5 describes the signal connections on the NI 5122/5124.

Table 5. NI 5122/5124 Front Panel Signal Connections

Connector	Description	Function
CH 0, CH 1	Standard BNC female connector	Analog input connection; digitizes data and triggers acquisitions.
TRIG	Standard BNC female connector	External analog trigger connection; signals on the TRIG connector cannot be digitized.
CLK IN	Standard SMB jack connector	Input for an external reference or sample clock to the digitizer.
CLK OUT	Standard SMB jack connector	Output for the reference or sample clock.
AUX I/O	9-pin mini-circular DIN connector (Figure 15)	Provides access to the multipurpose digital timing and triggering lines, PFI 0, and PFI 1 (with optional cable).

Figure 15 shows the pin assignments for the 9-pin DIN connector.

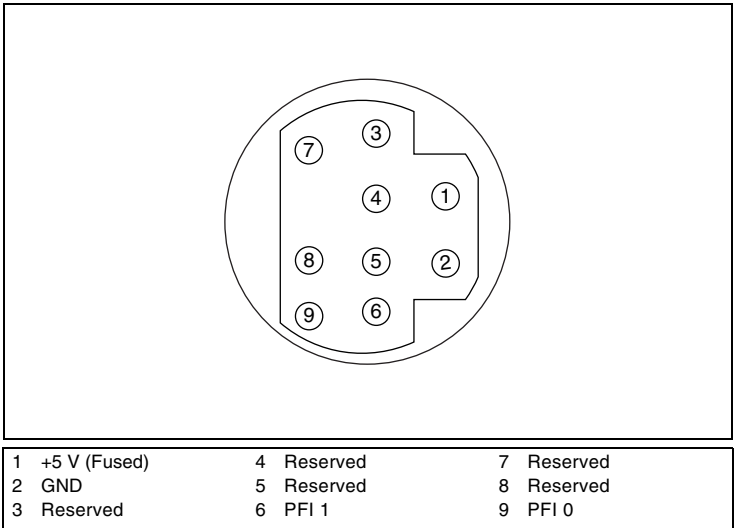

Figure 15. 9-Pin DIN Connector Pin Assignments for NI 5114/5122/5124/5922

NI 5620/5621 Front Panels

Figure 16 shows the NI PXI-5620/5621 front panels.

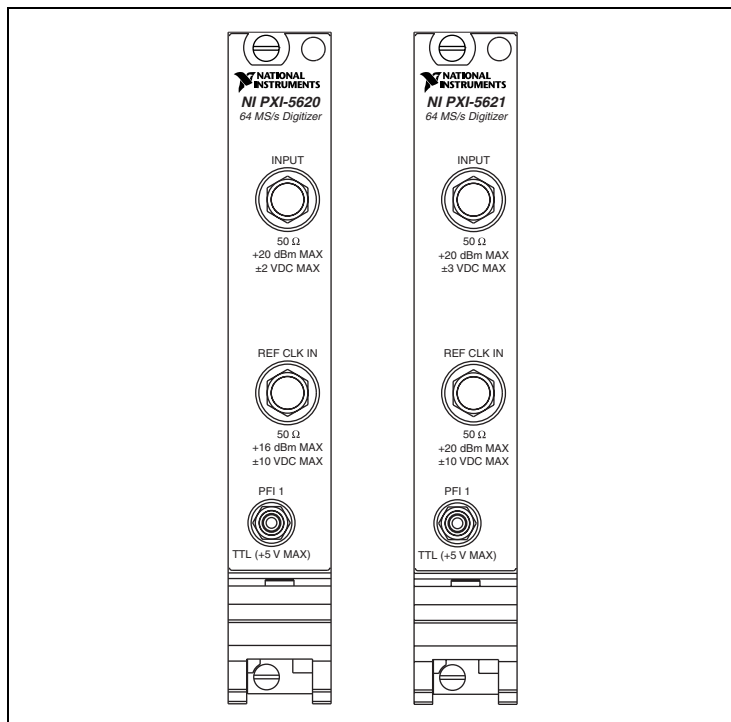

Figure 16. NI PXI-5620/5621 Front Panels

Table 6 describes the signal connections for the NI 5620/5621.

Table 6. NI 5620/5621 Front Panel Signal Connections

Connector	Description	Function
INPUT	Standard SMA female connector	Analog input connection; digitizes data and triggers acquisitions. NI 5620—50 Ω, AC coupled. NI 5621—50 Ω, DC coupled.
REF CLK IN	Standard SMA female connector	50 Ω, 10 MHz, AC coupled reference input.
PFI 1	Standard SMB jack connector	External digital trigger connection.

NI 5911 Front Panel

Figure 17 shows the NI 5911 front panel. Refer to Figure 8 for the PFI 2 (AUX) connector pinout information.

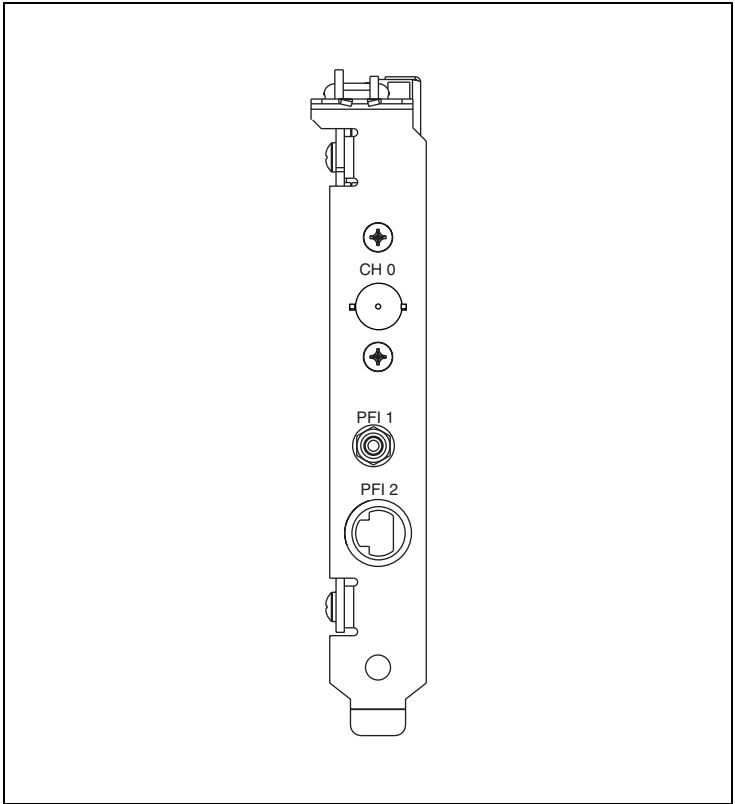

Figure 17. NI 5911 Front Panel

Table 7 describes the signal connections for the NI 5911.

Table 7. NI 5911 Front Panel Signal Connections

Connector	Description	Function
CH 0	Standard BNC female connector	Analog input connection; digitizes data and triggers acquisitions.

Table 7. NI 5911 Front Panel Signal Connections (Continued)

Connector	Description	Function
PFI 1	Standard SMB jack connector	Multipurpose digital timing and triggering signal.
PFI 2 (AUX)	9-pin mini-circular DIN connector (Figure 15)	Access to PFI 2 (with optional cable). Refer to Figure 8 for pinout information.

NI 5922 Front Panels

Figure 18 shows the NI PXI/PCI-5922 front panels. Refer to Figure 15 for the (AUX) connector pinout information.

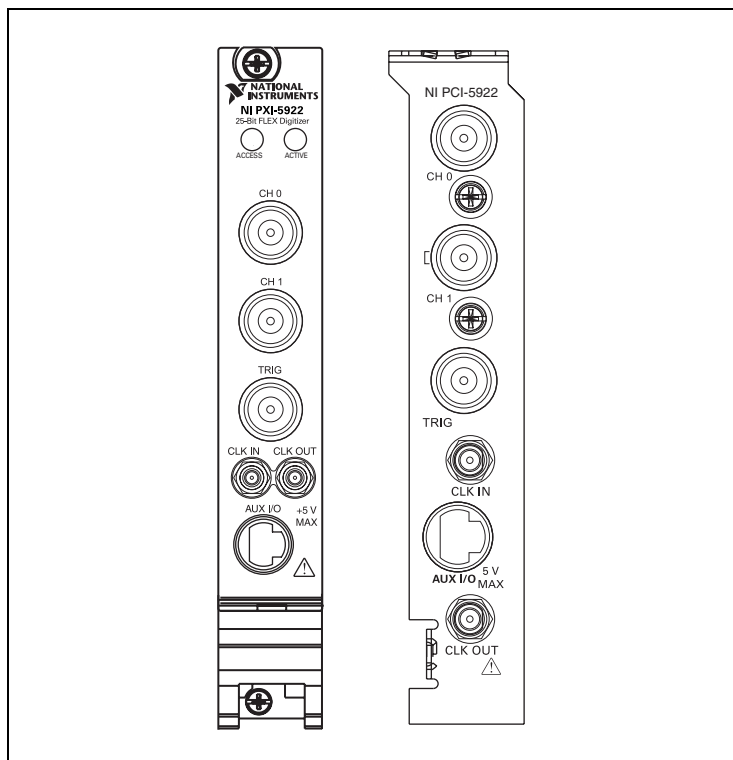

Figure 18. NI PXI/PCI-5922 Front Panels

Table 8 describes the signal connections for the NI PXI/PCI-5922.

Table 8. NI 5922 Front Panel Signal Connections

Connector	Description	Function
CH 0, CH 1	Standard BNC female connector	Analog input connection; digitizes data and triggers acquisitions.
TRIG	Standard BNC female connector	External analog trigger connection; signals on the TRIG connector cannot be digitized.
CLK IN	Standard SMB jack connector	Input for an external reference clock to the digitizer.
CLK OUT	Standard SMB jack connector	Output for the reference clock.
AUX I/O	9-pin mini-circular DIN connector (Figure 15)	Provides access to the multipurpose digital timing and triggering lines, PFI 0, and PFI 1 (with optional cable).

Appendix B: Troubleshooting

Device Front Panel ACCESS LED on PXI Module is Off When PXI Chassis is On

If the ACCESS LED is not lit after you power on the PXI chassis, a problem may exist with the PXI power rails, a hardware device, or the LED.



Note The LEDs may not light until the device has been configured in MAX. Before troubleshooting this issue, verify that the device appears in MAX.

Troubleshoot this issue by completing the following steps:

1. Power off your PXI chassis.
2. Disconnect any signals from the PXI module front panel.
3. Remove the PXI module and inspect for signs of damage. Do *not* reinstall a damaged device.
4. Reinstall the PXI module as described in step 5, *Installing the Hardware*.
5. Power on the PXI chassis.
6. Verify that the device appears in MAX.
7. Reset the device in MAX and perform a self-test. Refer to step 6, *Configuring and Testing in MAX* for information on performing device resets and self-tests in MAX.
8. If the ACCESS LED still fails to light, contact NI support at ni.com/support.

Device Does Not Appear in MAX

Complete the following steps if the device does not appear in MAX:

1. In the MAX Configuration pane, click **Devices and Interfaces** to expand the category.
2. Click **Traditional NI-DAQ Devices** or **NI-DAQmx Devices** and press <F5> to refresh the list of installed devices.
3. If the device is still not listed, power down the system, ensure that the device is correctly installed, and restart.
4. If the device still does not appear under Devices and Interfaces, contact NI support at ni.com/support.

Device Failed the Self-Test

The MAX self-test performs a brief test of device resources. If the device does not pass the self-test, complete the following steps:

1. Reboot your system.
2. Launch MAX and perform the self-test again. If the device still fails the self-test, proceed to step 3.
3. Uninstall and reinstall NI-SCOPE.
4. If the device still fails the self-test, contact NI support at ni.com/support.

Thermal Shutdown Error

I received the **kErrorDeviceShutDownDueToHighTemp** error, and my device shut down. What should I do next?

To re-enable your device after thermal shutdown, complete the following steps:

1. Power down the computer or chassis that contains the device.
2. Review the procedure in step 5. *Installing the Hardware* and make any necessary adjustments to ensure that your device is effectively cooled.
3. Power up the computer or chassis.



Note The thermal shutdown error is reported until the device has cooled down to an acceptable operating temperature and has been successfully reset.

Performance Issues Using MXI Connections

When you use a MXI connection to control a PXI chassis, the MXI Optimization Application must be run prior to using the device. By default, this application runs automatically when Windows starts. Using a MXI

connection without running this application may result in an error message such as the following:

- **maximum amount of time exceeded**
- **internal software error**

You may also experience initialization or performance issues when using the device.

If you are uncertain whether the MXI Optimization Application ran, navigate to **Start»Programs»National Instruments MXI** and select **MXI Optimization** to run the application.

If the application is not installed, use the MXI software CD or the *National Instruments Driver CD* included with your kit to install the software. After installation, you may need to reboot your computer before running the MXI Optimization Application.

If you continue to have initialization or performance issues, refer to the MXI documentation at **Start»Programs»National Instruments MXI**, or visit NI Technical Support at ni.com/support.

Setting Up NI-DAQmx Devices for Synchronization



Note The following step is required for any type of synchronization involving an NI-DAQmx device, including NI-TClk synchronization. For information about NI-TClk synchronization, refer to **NI High-Speed Digitizers Help»Programming»NI-TClk Synchronization Help**.

If you plan to share triggers and/or clocks for the purpose of synchronizing NI-DAQmx devices (for example, the NI 5114/5122/5124/5922), you must identify or configure certain components in MAX.

- ◆ For PXI devices, you must identify the PXI system controller by completing the following steps:
 1. In the MAX configuration tree,
 - a. Right-click **PXI System»Identify As**.
 - b. Select your controller from the list. For example, select External PC if you are using a MXI-3 controller in an external PC.
 2. Expand the PXI System tree and right-click the name of the chassis you are using.
- ◆ For PCI devices, you must configure the RTSI cable by completing the following steps:
 1. Connect a RTSI cable between the PCI devices to physically share triggers and/or clocks.

2. In the MAX configuration tree,
 - a. Right-click **NI-DAQmx Devices**.
 - b. Select **Create New NI-DAQmx Device»RTSI Cable**.
 - c. Right-click the RTSI cable, then select the device to add to the RTSI cable.

Appendix C: Where to Go for Support

The National Instruments Web site is your complete resource for technical support. At ni.com/support you have access to everything from troubleshooting and application development self-help resources to email and phone assistance from NI Application Engineers.

A Declaration of Conformity (DoC) is our claim of compliance with the Council of the European Communities using the manufacturer's declaration of conformity. This system affords the user protection for electronic compatibility (EMC) and product safety. You can obtain the DoC for your product by visiting ni.com/certification. If your product supports calibration, you can obtain the calibration certificate for your product at ni.com/calibration.

National Instruments corporate headquarters is located at 11500 North Mopac Expressway, Austin, Texas, 78759-3504.

National Instruments also has offices located around the world to help address your support needs. For telephone support in the United States, create your service request at ni.com/support and follow the calling instructions or dial 512 795 8248. For telephone support outside the United States, contact your local branch office:

Australia 1800 300 800, Austria 43 0 662 45 79 90 0,
Belgium 32 0 2 757 00 20, Brazil 55 11 3262 3599, Canada 800 433 3488,
China 86 21 6555 7838, Czech Republic 420 224 235 774,
Denmark 45 45 76 26 00, Finland 385 0 9 725 725 11,
France 33 0 1 48 14 24 24, Germany 49 0 89 741 31 30,
India 91 80 51190000, Israel 972 0 3 6393737, Italy 39 02 413091,
Japan 81 3 5472 2970, Korea 82 02 3451 3400, Lebanon 961 0 1 33 28 28,
Malaysia 1800 887710, Mexico 01 800 010 0793,
Netherlands 31 0 348 433 466, New Zealand 0800 553 322,
Norway 47 0 66 90 76 60, Poland 48 22 3390150,
Portugal 351 210 311 210, Russia 7 095 783 68 51,
Singapore 1800 226 5886, Slovenia 386 3 425 4200,
South Africa 27 0 11 805 8197, Spain 34 91 640 0085,
Sweden 46 0 8 587 895 00, Switzerland 41 56 200 51 51,
Taiwan 886 02 2377 2222, Thailand 662 278 6777,
United Kingdom 44 0 1635 523545

National Instruments, NI, ni.com, and LabVIEW are trademarks of National Instruments Corporation. Refer to the *Terms of Use* section on ni.com/legal for more information about National Instruments trademarks. Other product and company names mentioned herein are trademarks or trade names of their respective companies. For patents covering National Instruments products, refer to the appropriate location: **Help»Patents** in your software, the `patents.txt` file on your CD, or ni.com/patents.

© 2003–2005 National Instruments Corporation. All rights reserved.