

USER GUIDE

SCC-AO10 Isolated Analog Output Module

The SCC-AO10 is an isolated voltage output module with an output range of ± 10 V. The output voltage level is controlled by the DAC output of an E/M Series DAQ device. You can increase the output voltage level to ± 20 V by connecting two SCC-AO10 modules in series.

Conventions

The following conventions are used in this guide:

»

The » symbol leads you through nested menu items and dialog box options to a final action. The sequence **File»Page Setup»Options** directs you to pull down the **File** menu, select the **Page Setup** item, and select **Options** from the last dialog box.



This icon denotes a note, which alerts you to important information.



This icon denotes a caution, which advises you of precautions to take to avoid injury, data loss, or a system crash. When this symbol is marked on the product, refer to the *Read Me First: Safety and Radio-Frequency Interference* document, shipped with the product, for precautions to take.



When symbol is marked on a product it denotes a warning advising you to take precautions to avoid electrical shock.



When symbol is marked on a product it denotes a component that may be hot. Touching this component may result in bodily injury.

bold

Bold text denotes items that you must select or click in the software, such as menu items and dialog box options. Bold text also denotes parameter names.

italic

Italic text denotes variables, emphasis, a cross reference, an introduction to a key concept, or text as it appears on a hardware label. Italic text also denotes text that is a placeholder for a word or value that you must supply.

monospace

Text in this font denotes text or characters that you should enter from the keyboard, sections of code, programming examples, and syntax examples. This font is also used for the proper names of disk drives, paths, directories, programs, subprograms, subroutines, device names, functions, operations, variables, filenames, and extensions.

SC-2345

SC-2345 refers to both the SC-2345 connector block and the SC-2345 with configurable connectors.

SCC

SCC refers to any SCC Series signal conditioning module.

What You Need to Get Started

To set up and use the SCC-AO10, you need the following items:

- Hardware
 - SC-2345/2350 with one of the following:
 - SCC-PWR01
 - SCC-PWR02 and the PS01 power supply
 - SCC-PWR03 (requires a 7 to 42 VDC power supply, not included)
 - One or more SCC-AO10
 - 68-pin E/M Series DAQ device
 - 68-pin cable
 - Quick Reference Label
- Software
 - The latest version of NI-DAQmx
- Documentation
 - *SCC-AO10 Isolated Analog Output Module User Guide*
 - *SC-2345/2350 User Manual*
 - *SCC Quick Start Guide*
 - *Read Me First: Safety and Radio-Frequency Interference*
 - Documentation for your hardware
 - Documentation for your software
- Tools
 - 1/8 in. flathead screwdriver
 - Numbers 1 and 2 Phillips screwdrivers
 - Wire insulation stripper



Note Software scaling of measurements is not supported on the Macintosh operating system. Refer to the [SCC-AO10 Connector Pin Assignments](#) section.

You can download NI documents from ni.com/manuals. To download the latest version of NI-DAQmx, click **Download Software** at ni.com.

Device Specific Information



Note For general SCC module installation and signal connection information, and information about the SC-2345/2350 carrier, refer to the *SCC Quick Start Guide*, available for download at ni.com/manuals.

Installing the SCC-AO10



Caution Refer to the *Read Me First: Safety and Radio-Frequency Interference* document before removing equipment covers or connecting/disconnecting any signal wires.

Plug the SCC-AO10 into either SC-2345/2350 analog output socket J(X+17), where X is 0 or 1. The SC-2345/2350 routes the voltage output of E/M Series DAQ device analog output channel AO (X) to the SCC-AO10.

Connecting the SCC-AO10 to a Load



Caution Refer to the *Read Me First: Safety and Radio-Frequency Interference* document before removing equipment covers or connecting/disconnecting any signal wires.



Note The signal names have changed. Refer to ni.com/info and enter `rdtntg` to confirm the signal names.

The SCC-AO10 has a three-pin screw-terminal connector that accepts 28 to 16 AWG wires.

The screw terminals are labeled by pin numbers 1 to 3. Pin 1 is the isolated ground. Pins 2 and 3 both connect to the isolated voltage output for flexibility in field wiring.



Caution Connecting an external voltage source to the output terminals of the SCC-AO10 may damage the module.

Figures 1 and 2 show the SCC-AO10 connected to a nonreferenced load and to a load with a high common-mode voltage.

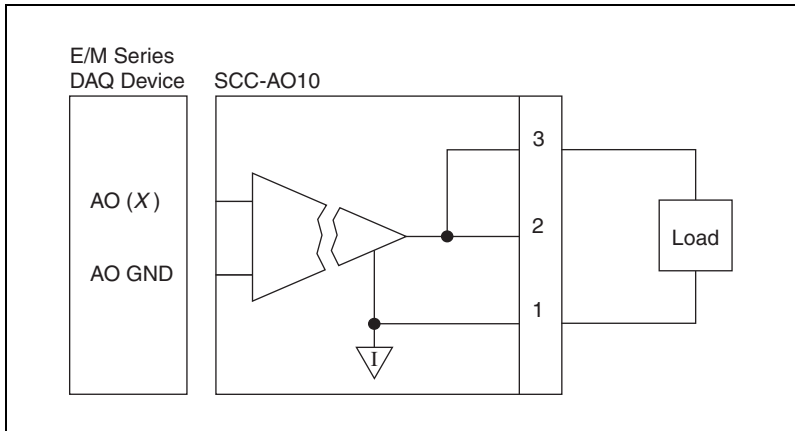

Figure 1. SCC-AO10 Connected to a Nonreferenced Load

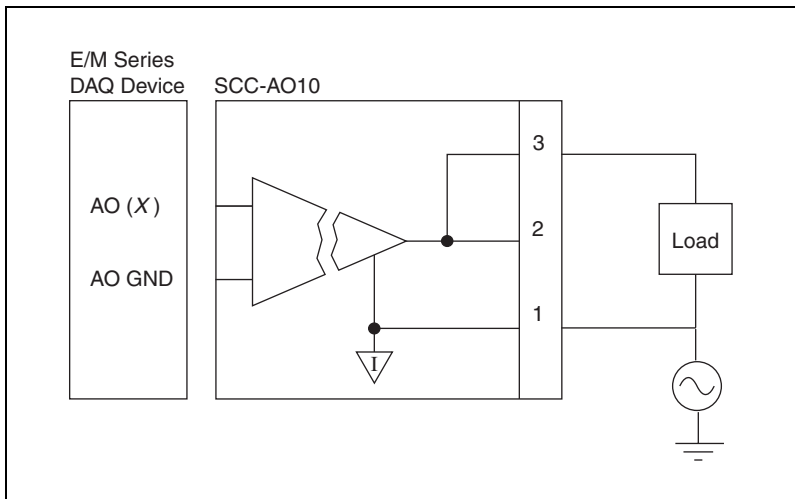

Figure 2. SCC-AO10 Connected to a Load with a High Common-Mode Voltage

Connecting Two SCC-AO10 Modules in Series

You can increase the maximum total output voltage to ± 20 V by connecting two SCC-AO10 modules in series. Plug the two modules into sockets J17 and J18 of the SC-2345/2350, and wire the modules to a load as shown in Figure 3.

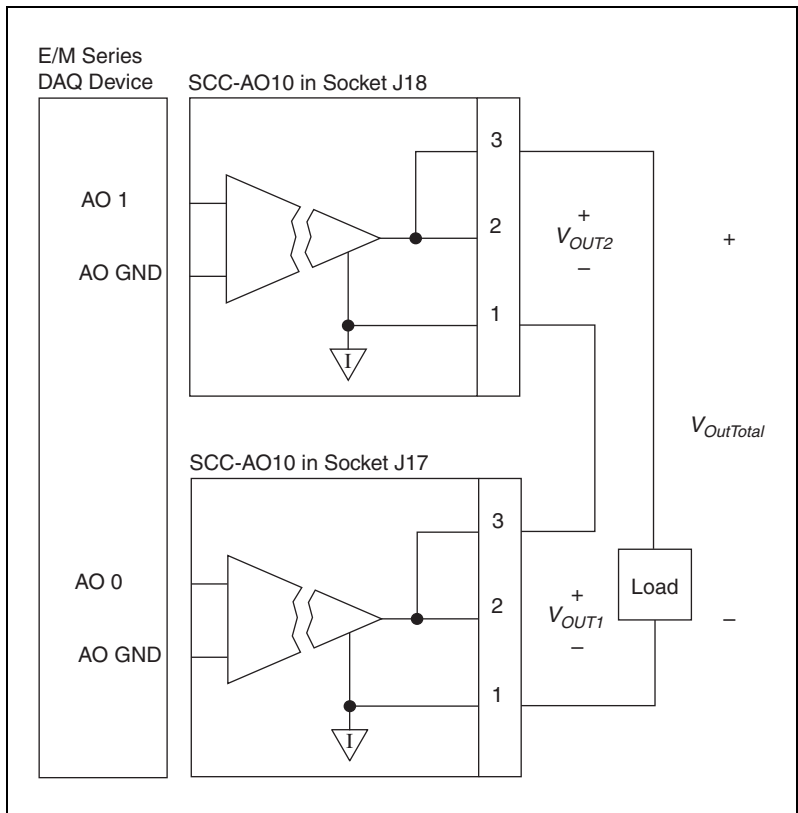

Figure 3. Connecting Two SCC-AO10 Modules in Series

The SC-2345/2350 routes the E/M Series DAQ device analog output channels AO 0 and AO 1 to the SCC-AO10 modules, and the resulting maximum output voltage range is ± 20 V. Refer to Figure 3 and use the following formula to calculate the total output voltage from both SCC-AO10 modules:

$$V_{OutTotal} = V_{OUT1} + V_{OUT2}$$

where

$V_{OutTotal}$ is the total output voltage from both SCC-AO10 modules

V_{OUT1} is the voltage across terminals 1 and 3 of the SCC-AO10 module in socket J17

V_{OUT2} is the voltage across terminals 1 and 3 of the SCC-AO10 module in socket J18

For information about how to configure the SCC-AO10 module with NI-DAQmx, refer to the *SCC Quick Start Guide*.

Using the SCC-AO10

This section contains information regarding scaling voltage measurements and isolated ground references.

Scaling Voltage Measurements

The SCC-AO10 is a ± 10 V isolated analog output module. The output voltage is controlled by an E/M Series DAQ device AO output channel, AO (X). The relationship between the AO (X) voltage level and the output voltage level of the SCC-AO10 is a one-to-one linear relationship. That is,

$$V_{AO(X)} = V_{AO10}$$

where

$V_{AO(X)}$ is the AO 0 voltage level

V_{AO10} is the SCC-AO10 voltage output in volts

Isolated Ground Reference

Each SCC-AO10 module is referenced to its own isolated ground. Each isolated ground can have up to 60 VDC of common-mode voltage between itself and any other channel ground or chassis ground. Refer to the [Connecting the SCC-AO10 to a Load](#) section for ways to use the isolated ground in signal connections.

Calibrating Gain and Offset Errors

The SCC-AO10 is calibrated at the factory before shipment. To adjust the gain and offset of the SCC-AO10 in your system using an E/M Series DAQ device, you need a voltage meter and a 1/8 in. flathead screwdriver. Before adjusting the SCC-AO10, allow 30 minutes for the DAQ device to warm up to its nominal operating temperature.

To adjust the gain and offset of the SCC-AO10, complete the following steps:

1. Disconnect the load from the SCC-AO10 you want to calibrate.
2. Set an output range of -10 to $+10$ V for AO (X), the E/M Series DAQ device channel connected to the SCC-AO10.
3. Connect the negative lead of the voltmeter to the isolated ground terminal (pin 1) and the positive lead to the voltage output terminal (pin 2 or 3) of the SCC-AO10.
4. Using your software, set AO (X) to output 0 VDC.

5. Adjust the offset potentiometer on the top of the SCC-AO10 until the voltmeter reads $0 \text{ VDC} \pm 100 \mu\text{V}$. The offset is now calibrated.
6. Using your software, have AO (X) output 9.9 VDC.

Adjust the gain potentiometer on the top of the SCC-AO10 until the voltmeter reads 9.9 VDC. The gain is now calibrated.

Specifications

These ratings are typical at 25 °C unless otherwise stated.

Electrical

Number of output channels	One nonreferenced (floating)
Input range	$\pm 10 \text{ V}$
Output range.....	$\pm 10 \text{ V}$
Current drive	$\pm 30 \text{ mA}$
Gain nonlinearity.....	0.5% of full-scale output range
Output noise	$2.5 \text{ mV}_{\text{rms}}$ typ; $4 \text{ mV}_{\text{rms}}$ max
Bandwidth	$>23 \text{ kHz}$
Slew rate.....	$1 \text{ V}/\mu\text{s}$
Short circuit protection	
Current	37 mA max
Duration	Unlimited
Load impedance	$10,000 \text{ pF}$ max

Power Requirement

Analog power	180 mW max at full load 172 mW max with no load
+15 V	6 mA max at full load 5.73 mA max with no load
-15 V	6 mA max at full load 5.73 mA max with no load
Digital power (+5 V)	1.15 W max at full load 600 mW max with no load
+5 V	230 mA max 120 mA max with no load

Physical

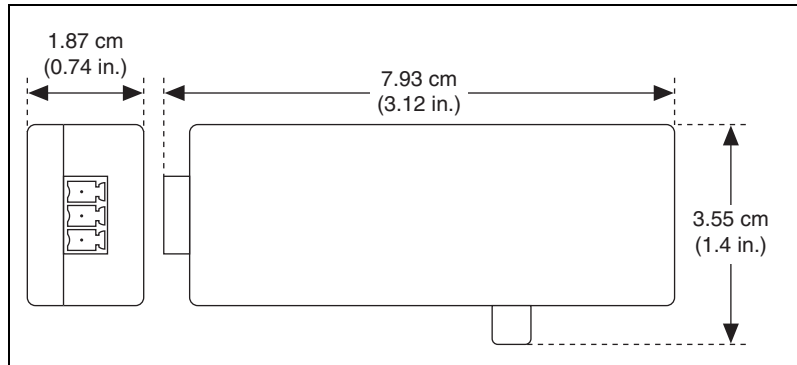

Figure 4. SCC-A010 Dimensions

Weight	28 g (1.0 oz)
I/O connectors.....	One 20-pin right-angle male connector; one 3-pin screw terminal
Field-wiring diameter	28 to 16 AWG

Maximum Working Voltage

(Signal + common-mode) each input should remain within $42.4 V_{\text{peak}}$ or 60 VDC of ground.

Maximum working voltage refers to the signal voltage plus the CMV.

Channel-to-earth (inputs) $42.4 V_{\text{peak}}$ or 60 VDC,
Measurement Category I



Caution This device is rated for Measurement Category I and is intended to carry signal voltages no greater than $42.4 V_{\text{peak}}$ or 60 VDC. Do not use this device for connection to signals or for measurements within Categories II, III, or IV.

Isolation Voltage

Channel-to-earth isolation

Continuous 60 VDC,
Measurement Category I

Withstand $2300 V_{\text{rms}}$ verified by a 5 s
dielectric withstand test

Environmental

Operating temperature 0 to 50 °C

Storage temperature -20 to 70 °C

Humidity 10 to 90% RH, noncondensing

Maximum altitude 2,000 m

Pollution Degree (indoor use only) 2

Stability

Recommended warm-up time 10 min (30 min for connected
E/M Series DAQ device)

Output offset drift $300 \mu\text{V}/^\circ\text{C}$

Gain temperature coefficient $300 \text{ ppm}/^\circ\text{C}$

Safety

The SCC-AO10 is designed to meet the requirements of the following standards of safety for electrical equipment for measurement, control, and laboratory use:

- IEC 61010-1, EN 61010-1
- UL 61010-1
- CAN/CSA-C22.2 No. 61010-1



Note For UL and other safety certifications, refer to the product label, or visit ni.com/certification, search by model number or product line, and click the appropriate link in the Certification column.

Electromagnetic Compatibility

Emissions	EN 55011 Class A at 10 m FCC Part 15A above 1 GHz
Immunity	EN 61326:1997 + A2:2001, Table 1
EMC/EMI	CE, C-Tick, and FCC Part 15 (Class A) Compliant



Note For EMC compliance, operate this device with shielded cabling.

CE Compliance

The SCC-AO10 meets the essential requirements of applicable European Directives, as amended for CE marking, as follows:

Low-Voltage Directive (safety).....73/23/EEC

Electromagnetic Compatibility
Directive (EMC).....89/336/EEC



Note Refer to the Declaration of Conformity (DoC) for this product for any additional regulatory compliance information. To obtain the DoC for this product, visit ni.com/certification, search by model number or product line, and click the appropriate link in the Certification column.

SCC-AO10 Connector Pin Assignments

Figure 5 shows the I/O connector pins on the bottom of the SCC-AO10.

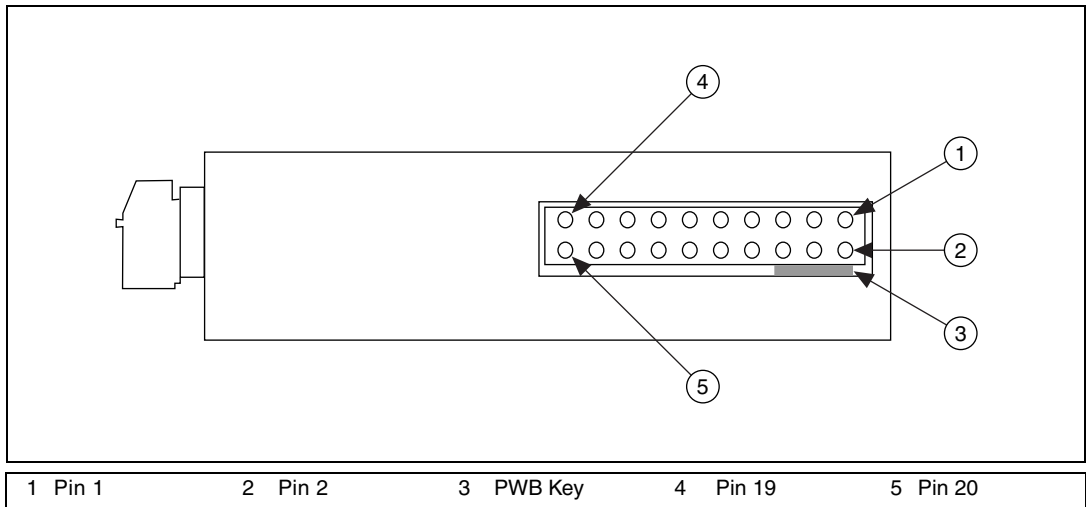

Figure 5. SCC Module Bottom View

Table 1 lists the signal connection corresponding to each pin.

Table 1. SCC-AO10 I/O Connector Signal Assignments

Pin Number	Signal
1	E/M Series AO (X)
2	E/M Series AO GND
3	—
4	E/M Series AO GND
5	—
6	—
7	—
8	—
9	+5 V
10	GND
11	—
12	+ 5 V reference

Table 1. SCC-A010 I/O Connector Signal Assignments (Continued)

Pin Number	Signal
13	+15 V
14	-15 V
15'	—
16	—
17	—
18	—
19	—
20	—

National Instruments, NI, ni.com, and LabVIEW are trademarks of National Instruments Corporation. Refer to the *Terms of Use* section on ni.com/legal for more information about National Instruments trademarks. Other product and company names mentioned herein are trademarks or trade names of their respective companies. For patents covering National Instruments products, refer to the appropriate location: **Help»Patents** in your software, the `patents.txt` file on your CD, or ni.com/patents.