

USER GUIDE

Universal Motion Interface (UMI)-7764

This document provides information about the National Instruments Universal Motion Interface (UMI)-7764 functionality and includes instructions for getting started, specifications, connection requirements, and safety information.

Contents

Introduction.....	1
Related Resources.....	1
Features.....	2
What You Need to Get Started.....	2
Optional Equipment.....	2
Installation.....	2
Connecting the UMI-7764 to Optional General-Purpose Digital I/O Devices.....	3
Terminal Block Descriptions.....	4
Power Input Terminal Block.....	5
Motion I/O Terminal Block.....	5
Specifications.....	11
Where to Go for Support.....	14

Introduction

The UMI-7764 is a standalone connectivity accessory designed to be used with National Instruments 7330, NI 7340, and NI 7350 series motion controllers for up to four axes of simultaneous or independent control. Ideally suited to industrial and laboratory applications, the UMI-7764 connects third-party stepper and servo drives (amplifiers) and/or feedback and digital I/O to National Instruments motion controllers.



Note For consistency, the remainder of this document refers only to drives. All references to drives also apply to amplifiers.

To work correctly with the UMI-7764, drives must have industry standard interfaces. For stepper systems, the industry standard interface includes step and direction, or clockwise (CW) and counter-clockwise (CCW), pulse inputs. For servo systems, the industry standard interface includes a ± 10 V analog input.

Related Resources

The following documents contain information that you may find helpful as you read this document. Many of the documents listed are available as PDFs on ni.com/manuals.

- NI 7330, NI 7340, or NI 7350 motion controller documentation
- *Measurement & Automation Explorer Help for Motion*
- Documentation included with your drive

Features

The UMI-7764 simplifies field wiring by supplying separate encoder, limit switch, and amplifier/drive terminal blocks per axis. All terminal blocks are industry standard and do not require any special tools or wire installation. The UMI connects to the motion controller through a single interface cable. Also, the UMI features a host bus monitor power interlock that automatically disables the drive if the host computer is shut down or the interface cable is disconnected.

The UMI-7764 is encased in a metal box with a hinged lid and comes with attached rubber feet for desktop use.



Note Throughout this document, overlined text indicates that a signal is active-low.

What You Need to Get Started

To set up and use your UMI accessory, you will need the following items:

- NI UMI-7764 accessory and documentation
- NI 7330, NI 7340, or NI 7350 motion controller and documentation
- National Instruments SH68-C68-S cable
- +5 V power supply
- Third-party drive and documentation

Refer to the [Specifications](#) section for detailed specifications.

Optional Equipment

National Instruments offers the following products for use with the UMI-7764:

- Additional SH68-C68-S cable with 68-pin VHDCI offset male connectors on both ends. Use this cable to connect the digital I/O connector on the National Instruments motion controller to the National Instruments SCB-68.
- National Instruments SCB-68 for digital I/O connection.

Installation

Complete the following steps to install the UMI-7764:

1. Connect the +5 V power supply to the UMI-7764.
2. Connect the power, motor, and encoder to the drive as specified in the drive documentation.
3. Connect the UMI-7764 to the motion controller using the SH68-C68-S cable.
4. Connect the drive to the UMI-7764.
5. Connect any external switches and I/O to the UMI-7764.
6. Test the signal connections starting with the limit and home switches, then the encoders, and concluding with the inhibit and command connections.

Figure 1 shows a simplified connection diagram.

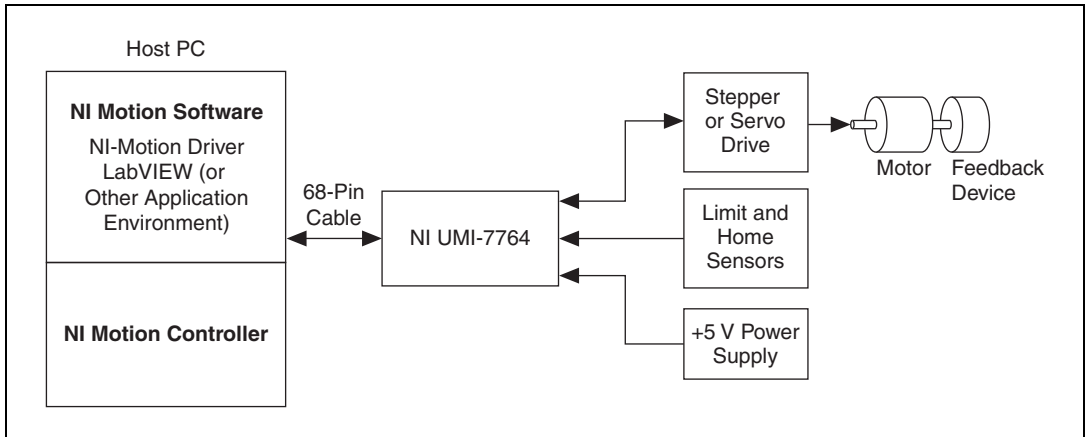

Figure 1. Connecting the UMI-7764

Connecting the UMI-7764 to Optional General-Purpose Digital I/O Devices

To access the digital I/O signals on the National Instruments motion controller, connect one end of an additional SH68-C68-S cable to the 68-pin digital I/O connector on the motion controller and the other end to the 68-pin connector on the SCB-68.

Optionally, you can connect the digital I/O connector on the motion controller to other National Instruments accessories. For example, you can connect the digital I/O on the National Instruments motion controller to an SSR cable adapter and then connect that adapter to the National Instruments SSR Series backplanes for use with other National Instruments devices, such as DAQ devices.

Terminal Block Descriptions

This section describes the UMI-7764 terminal block. Refer to Figure 2 to locate the different parts of the UMI-7764 accessory.

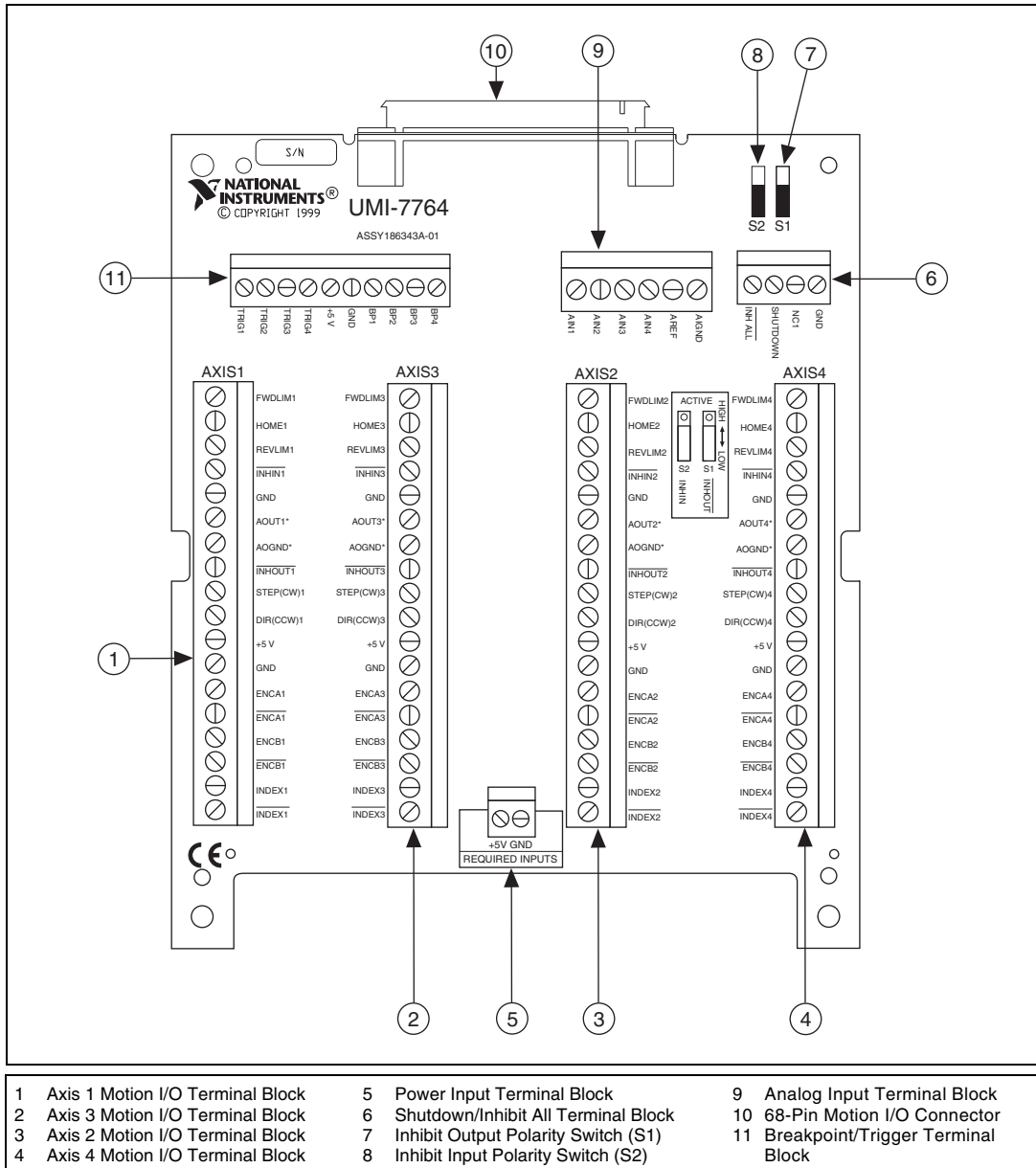

Figure 2. UMI-7764 Parts Locator Diagram



Note Signals marked with an asterisk (*) are not available on the NI 7330 motion controller.

Power Input Terminal Block

The UMI-7764 has a 2-position terminal block for wiring power to the unit. Refer to Figure 2 to locate the power input terminal block on your UMI-7764 accessory. Figure 3 shows the 2-position terminal block pinout.

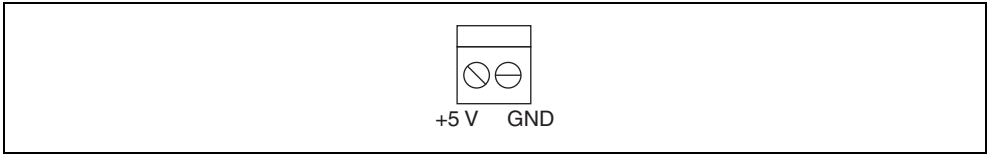

Figure 3. 2-Position Power Input Terminal Block Pin Assignment

This connection is required to power the encoder circuitry that converts differential encoder signals to single-ended signals for the motion controller, as well as to power the UMI-7764 Inhibit Output signals.

The +5 V power is also distributed to the per-axis +5 V supply on the Motion I/O Terminal Blocks. The +5 V per-axis supply on the Motion I/O Terminal Blocks can be used to power encoders, limit switches, or other general-purpose devices.

Motion I/O Terminal Block

Each axis connected to the UMI-7764 has a motion I/O terminal block to which the following signals are wired:

- Amplifier/drive connections
- Encoder connections
- Limit switch connections
- Distributed power connections

Figure 4 shows which portions of the terminal block are used for different functionality.

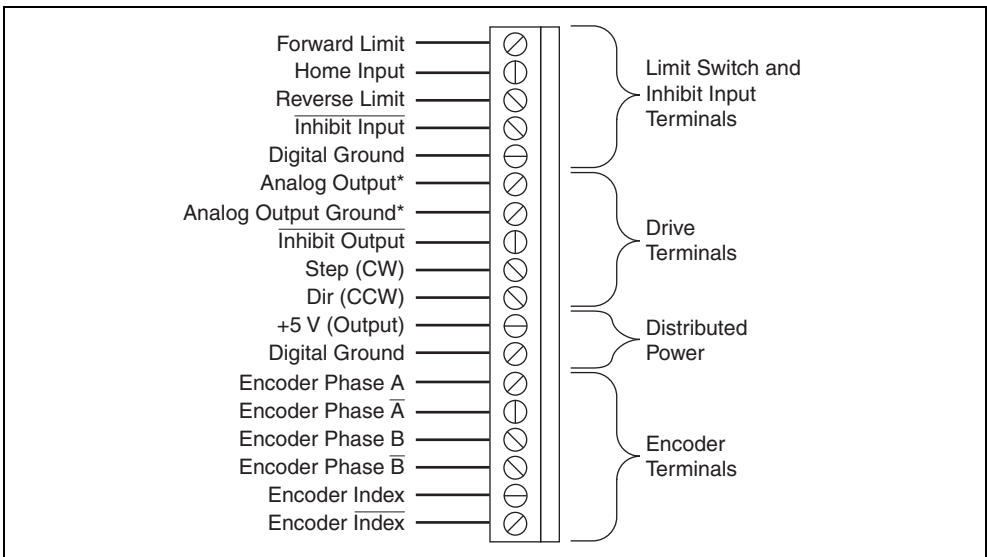

Figure 4. UMI-7764 Motion I/O Terminal Block



Note Signals marked with an asterisk (*) are not available on the NI 7330 motion controller.

Drive Terminal Block

Each UMI-7764 axis motion I/O terminal block has five terminals for drive connections. Refer to Figures 2 and 4 to locate the drive terminals on your UMI-7764 accessory. Figure 5 shows the UMI-7764 drive terminal block pin assignment for the servo or stepper axes.

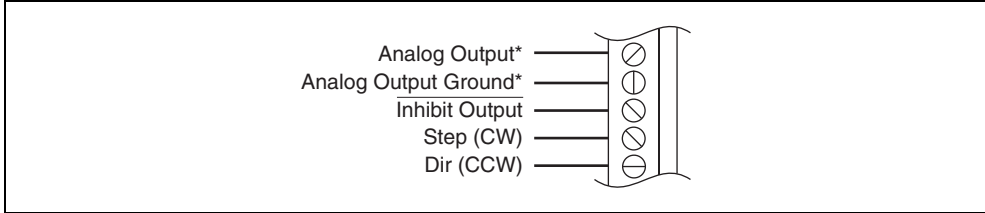

Figure 5. UMI-7764 Axes Amplifier/Drive Terminal Block Pin Assignments



Note Signals marked with an asterisk (*) are not available on the NI 7330 motion controller.

- **Analog Output**—The Analog Output signals are used as command outputs to a servo amplifier or as general-purpose voltage outputs. These signals are pass-through signals from the controller to the drive, and all output signal configuration is performed by the motion controller.
- **Step and Dir**—The Step and Dir signals are used as command outputs to a stepper drive. Some stepper drives require clockwise direction (CW) and counter-clockwise direction (CCW) commands rather than Step and Dir commands. You can configure National Instruments motion controllers to provide either type of stepper commands. Both Step and Dir signals are pass-through signals.

Many stepper drive manufacturers offer opto-isolated inputs for Step (CW)/Direction (CCW) signals. When connecting to opto-isolated inputs, connect the UMI-7764 Step output to the negative (cathode) side of the optocoupler input, and connect the positive (anode) side of the drive input to a supply as specified by the drive manufacturer. Figure 6 shows a connection example.

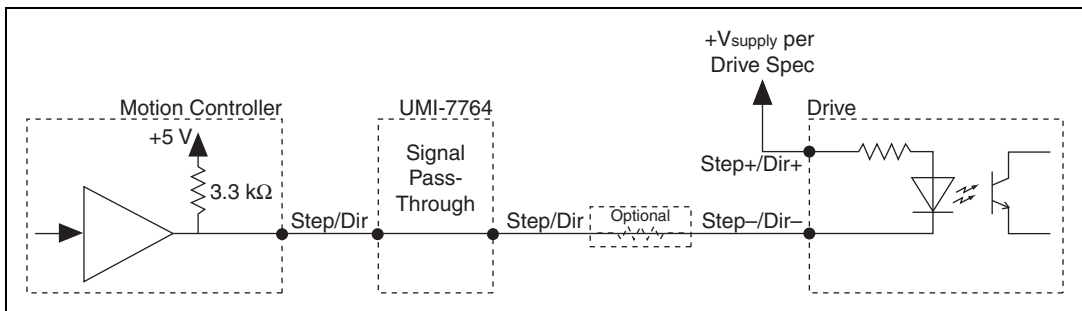

Figure 6. Opto-Isolated Step and Direction Output Connection



Caution If the drive optocoupler input does *not* include its own current-limiting resistor, you must provide an external resistor in series with the UMI output. To prevent damage to the UMI or stepper drive, use a resistor that limits the current to a value below the maximum specifications of the UMI, motion controller, and stepper drive. Refer to the [Specifications](#) section for more information.

- **Inhibit Output**—The Inhibit Output signals are used to disable the drive for that axis. The UMI combines the host bus interlock circuit, the Inhibit All signal, the per axis Inhibit Input signals, and the per axis controller Inhibit Output to create the per axis Inhibit Output signal as shown in Table 1.

Table 1. UMI-7764 Inhibit Output Active Conditions

UMI-7764 Inhibit Input	Motion Controller Inhibit Output	UMI-7764 Inhibit All	UMI-7764 Host Bus Interlock	UMI-7764 Inhibit Output
Active	—	—	—	Active
—	Active	—	—	Active
—	—	Active	—	Active
—	—	—	Problem with +5 V input from motion controller	Active

The host bus interlock monitors the host PC +5 V power supply from the motion controller to verify that the controller is powered and properly connected to the UMI. If the host bus interlock detects a problem, if the Inhibit All signal is asserted, or if the Inhibit Input signal or the controller Inhibit Output signal for that axis is asserted, the Inhibit Output from the UMI-7764 for that axis is asserted.

You can configure the axis Inhibit Out signal as active-low or active-high using switch S1. Refer to Figure 2 to locate switch S1 on your UMI-7764. Setting S1 to the bottom configures the signal as active-low; setting S1 to the top configures the signal as active-high.



Note The motion controller Inhibit Output signals must be set to active-low for proper operation of the inhibit circuitry. This is the default software setting so no action is required unless the setting has been changed from the default.

Encoder Terminal Block

Each UMI-7764 axis motion I/O terminal block has six terminals for incremental encoder connections. The UMI-7764 accepts either single-ended TTL or differential line driver inputs. You can connect open-collector encoders to the UMI-7764 accessory by installing a 2.2 kΩ pull-up resistor to +5 V.



Note Encoders with line driver outputs are recommended for all applications and must be used if the encoder cable length is greater than 10 feet.

Power for the encoders is internally routed from the power input terminal block and is available on the +5 V terminal on each axis motion I/O terminal block. Refer to Figures 2 and 4 to help you locate the encoder terminals on your UMI-7764 accessory. Figure 7 shows the pinout for a differential encoder.



Note The dotted loop indicates a shielded cable.

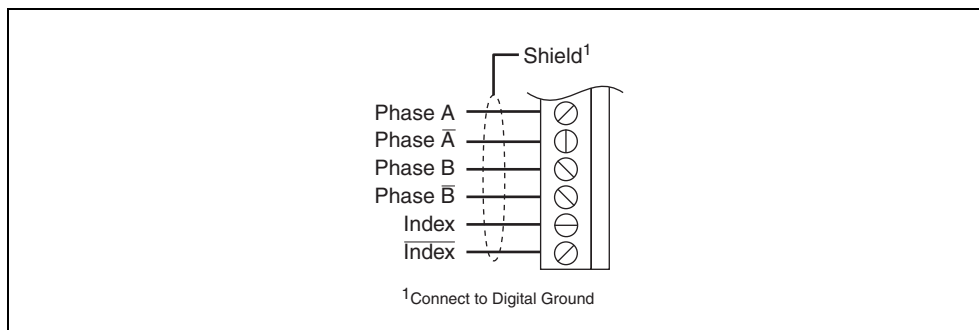

Figure 7. Differential Encoder Pin Assignments

Figure 8 shows the pinout for the single-ended encoder.

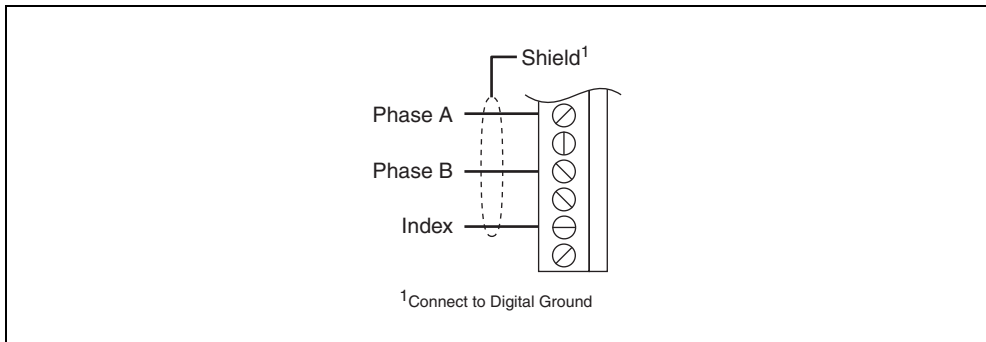

Figure 8. Single-Ended Encoder Pin Assignments

The UMI-7764 accessory allows for differential inputs for Phase A, Phase B, and Index signals. You can easily accommodate encoders with phase relationships different from Figure 9 by swapping the signals as required by the specific application. The Index pulse must occur when both Phase A and Phase B signals are logic low as shown in Figure 9. Servo and closed-loop stepper applications require encoder feedback and consistent directional polarity between the motor and encoder for stable operation. The UMI-7764 uses the following standards for motor direction:

- Positive = forward = Clockwise (CW) facing motor shaft
- Negative = reverse = Counter-clockwise (CCW) facing motor shaft

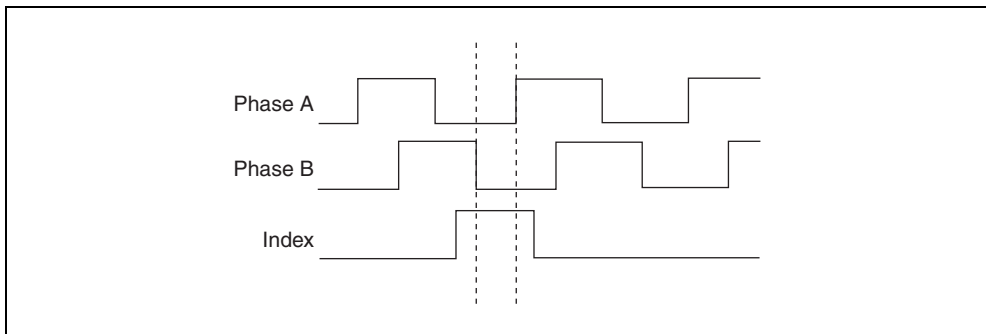

Figure 9. Encoder Signal Phasing—CW Rotation

The encoder inputs are filtered by both analog and digital noise filters. You must use cables with twisted pairs and an overall shield for improved noise immunity. When connecting the encoder to the UMI-7764, you should use at least 24-AWG wire.



Caution Using an unshielded cable allows noise to corrupt the encoder signals, which results in lost counts, reduced accuracy, and other erroneous encoder and controller operations.

Limit Switch and Inhibit Input Terminal Block

Each UMI-7764 axis motion I/O terminal block has five terminals for Forward Limit, Reverse Limit, Home switch, and Inhibit Input connections. Refer to Figures 2 and 4 to locate the terminals on your UMI-7764 accessory. Refer to Figure 10 for the UMI-7764 limit switch and Inhibit Input terminal block pinout.

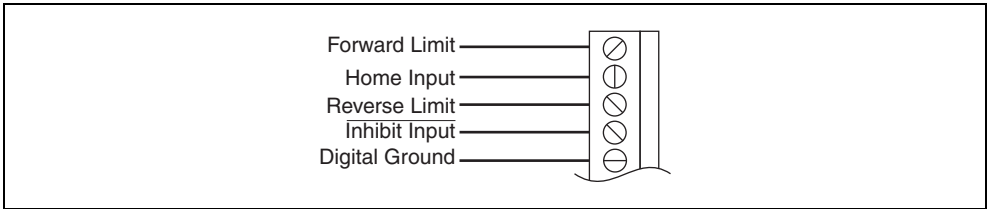

Figure 10. UMI-7764 Limit Switch and Inhibit Input Terminal Block Pin Assignment

- **Limit and Home Inputs**—The limit sensors or switches are typically located at physical ends of travel. The home sensor or switch can be located at any reference position within the range of travel. For the end of travel limits to function correctly, the forward limit must be located at the forward or positive end of travel, and the reverse limit must be located at the negative end of travel.
- **Inhibit Input**—The axis Inhibit Input is typically connected to the Drive Fault output. When the Inhibit Input is asserted the UMI asserts the Inhibit Output signal. You can configure the axis Inhibit Input signals as active-low or active-high inputs using switch S2. Setting S2 to the bottom configures the signal as active-low; setting S2 to the top configures the signal as active-high. The Inhibit Input signals include a 3.3 k Ω pull-up resistor on their inputs. If you are not using the Inhibit Input signal you can leave it unconnected but set switch S2 to the bottom to configure the signal as active-low.

Analog Input Terminal Block

For analog input wiring, the UMI-7764 has a 6-position terminal block, which provides access to the four analog input channels on your motion controller. Refer to Figure 2 to locate the analog input terminal block on your UMI-7764 accessory. Refer to Figure 11 for the analog input terminal block pinout.

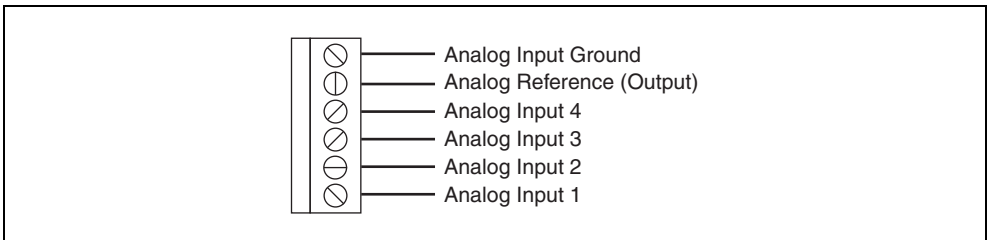

Figure 11. UMI-7764 Analog Input Terminal Block Pin Assignments

Breakpoint Output/Trigger Input Terminal Block

For breakpoint output and trigger input wiring, the UMI-7764 has a 10-position terminal block. This terminal block provides access to the four breakpoint outputs and the four trigger inputs. Refer to Figure 2 to locate the breakpoint output/trigger input terminal block on your UMI-7764 accessory. Refer to Figure 12 for the breakpoint output and trigger input pinout.

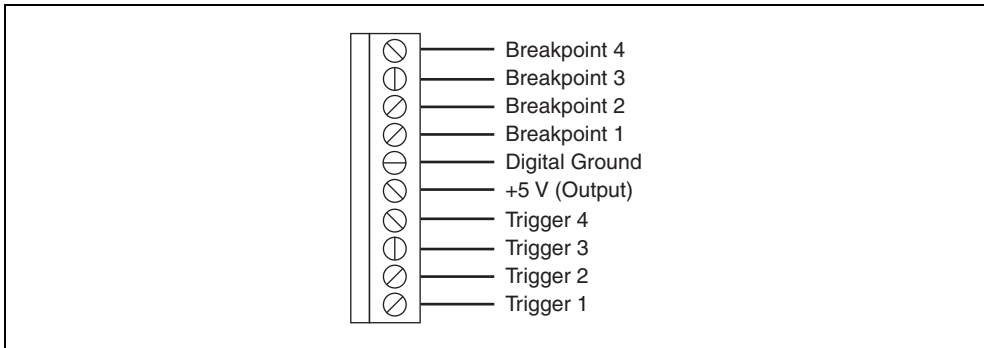

Figure 12. UMI-7764 Breakpoint/Trigger Terminal Block Pin Assignments

Shutdown/Inhibit All Terminal Block

The UMI accessory has a 4-position terminal block for shutdown and inhibit all wiring. Refer to Figure 2 to locate the shutdown/inhibit all terminal block on your UMI-7764 accessory. Refer to Figure 13 for the shutdown/inhibit all pinout.

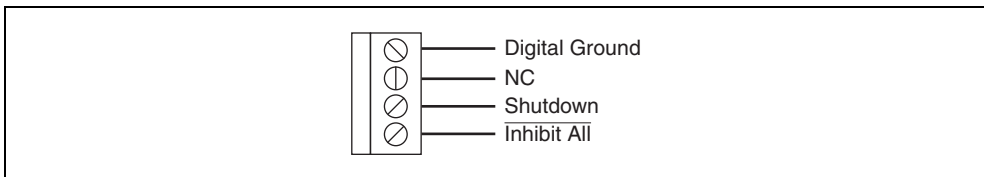

Figure 13. Shutdown/Inhibit All Terminal Block Pin Assignments

- **Inhibit All**—The Inhibit All signal acts as a global inhibit, and, when driven low, activates the Inhibit Outputs. The Inhibit All signal includes a 3.3 k Ω pull-up resistor on its input. You can leave the Inhibit All signal unconnected if it is not used.
- **Shutdown**—The Shutdown signal is passed through to the motion controller and, when enabled in software, disables the controller by asserting the controller inhibits, setting the analog outputs to 0 V, and stopping any stepper pulse generation.



Caution Do *not* connect anything to the NC/NC1 connector on the UMI. The NC connector has no functionality for the operation of the UMI or the motion controller connected to it, but is connected to an input on the UMI which is connected to the motion controller. This input may handle at most 5 V. Connecting higher voltages to the NC/NC1 terminal may damage the UMI or the motion controller.

Specifications

The following specifications apply only to the UMI-7764 accessory. Consider the specifications for the National Instruments motion controller and third-party drive you are using to obtain a complete system specification. Refer to your controller specifications to determine overall system specifications.

Some signals have compatibility defined as signal pass-through. This means the UMI-7764 may have passive filtering on these signals but the passive filtering does not affect the voltage range or current handling capability. Consult the motion controller specifications to determine the allowable voltage range and logic level compatibility of the signal.

These specifications are typical at 25 °C unless otherwise specified. Refer to your motion controller user manual for detailed specifications on encoder inputs, limit and home switch inputs, breakpoint outputs, trigger inputs, and analog inputs.

Encoder Interface (Each Axis)

Inputs	Quadrature, incremental
Differential input threshold	±0.3 V (typical)
Single-ended input threshold	TTL/CMOS
Voltage range	0 to 5 VDC
Noise filter (RC time constant)	100 ns
Max quadrature frequency	20 MHz

Limit and Home Switch Inputs (Each Axis)

Noise filter (RC time constant)	10 µs
Compatibility	Signal pass-through

Trigger Inputs

Noise filter (RC time constant)	100 ns
Compatibility	Signal pass-through

Inhibit and Inhibit All Inputs

Voltage range	0 to 12 VDC
Input voltage threshold	TTL/CMOS
Input pull-up resistor	3.3 kΩ
Compatibility	Signal pass-through

Analog Inputs

Noise filter (RC time constant)	10 µs
Compatibility	Signal pass-through

Analog Outputs

Compatibility	Signal pass-through
---------------------	---------------------

Axis Inhibit Out

Voltage range	0 to 5 VDC
Output low voltage.....	0.5 V at 16 mA
Output high voltage.....	2.4 V at 3.2 mA

Step/Dir/Breakpoint Outputs

Compatibility	Signal pass-through
---------------------	---------------------

Trigger Inputs

Compatibility	Signal pass-through
---------------------	---------------------

Power Requirements

+5 VDC.....	0.2 amps + user-defined encoder and limit power
-------------	-------------------------------------------------

Host Bus Voltage Interlock

Voltage	5 VDC \pm 5%
---------------	----------------

Physical

Dimensions	19.5 \times 15.2 \times 4.5 cm (7.7 \times 6.0 \times 1.8 in.)
------------------	---------------------------------------------------------------------------



Note For two-dimensional drawings and three-dimensional models of the UMI-7764 enclosure, go to ni.com/dimensions and search for the SCB-68, which uses the same enclosure.

Environment

Temperature	0 to 55 °C
Storage temperature	-20 to 70 °C
Relative humidity	10 to 90% (noncondensing)
Maximum altitude.....	2,000 m
Pollution Degree	2

Safety

This product meets the requirements of the following standards of safety for electrical equipment for measurement, control, and laboratory use:

- IEC 61010-1, EN 61010-1
- UL 61010-1, CSA 61010-1



Note For UL and other safety certifications, refer to the product label or the [Online Product Certification](#) section.

Electromagnetic Compatibility

This product meets the requirements of the following EMC standards for electrical equipment for measurement, control, and laboratory use:

- EN 61326 (IEC 61326): Class A emissions; Basic immunity
- EN 55011 (CISPR 11): Group 1, Class A emissions
- AS/NZS CISPR 11: Group 1, Class A emissions
- FCC 47 CFR Part 15B: Class A emissions
- ICES-001: Class A emissions



Note For the standards applied to assess the EMC of this product, refer to the *Online Product Certification* section.

CE Compliance

This product meets the essential requirements of applicable European Directives as follows:

- 2006/95/EC; Low-Voltage Directive (safety)
- 2004/108/EC; Electromagnetic Compatibility Directive (EMC)

Online Product Certification

Refer to the product Declaration of Conformity (DoC) for additional regulatory compliance information. To obtain product certifications and the DoC for this product, visit ni.com/certification, search by module number or product line, and click the appropriate link in the Certification column.

Environmental Management

National Instruments is committed to designing and manufacturing products in an environmentally responsible manner. NI recognizes that eliminating certain hazardous substances from our products is beneficial to the environment and to NI customers.

For additional environmental information, refer to the *NI and the Environment* Web page at ni.com/environment. This page contains the environmental regulations and directives with which NI complies, as well as other environmental information not included in this document.

Waste Electrical and Electronic Equipment (WEEE)



EU Customers At the end of the product life cycle, all products must be sent to a WEEE recycling center. For more information about WEEE recycling centers, National Instruments WEEE initiatives, and compliance with WEEE Directive 2002/96/EC on Waste and Electronic Equipment, visit ni.com/environment/weee.

电子信息产品污染控制管理办法（中国 RoHS）



中国客户 National Instruments 符合中国电子信息产品中限制使用某些有害物质指令 (RoHS)。关于 National Instruments 中国 RoHS 合规性信息, 请登录 ni.com/environment/rohs_china。(For information about China RoHS compliance, go to ni.com/environment/rohs_china.)

Where to Go for Support

The National Instruments Web site is your complete resource for technical support. At ni.com/support you have access to everything from troubleshooting and application development self-help resources to email and phone assistance from NI Application Engineers.

A Declaration of Conformity (DoC) is our claim of compliance with the Council of the European Communities using the manufacturer's declaration of conformity. This system affords the user protection for electromagnetic compatibility (EMC) and product safety. You can obtain the DoC for your product by visiting ni.com/certification. If your product supports calibration, you can obtain the calibration certificate for your product at ni.com/calibration.

National Instruments corporate headquarters is located at 11500 North Mopac Expressway, Austin, Texas, 78759-3504. National Instruments also has offices located around the world to help address your support needs. For telephone support in the United States, create your service request at ni.com/support and follow the calling instructions or dial 512 795 8248. For telephone support outside the United States, contact your local branch office:

Australia 1800 300 800, Austria 43 662 457990-0, Belgium 32 (0) 2 757 0020,
Brazil 55 11 3262 3599, Canada 800 433 3488, China 86 21 5050 9800,
Czech Republic 420 224 235 774, Denmark 45 45 76 26 00, Finland 358 (0) 9 725 72511,
France 01 57 66 24 24, Germany 49 89 7413130, India 91 80 41190000, Israel 972 3 6393737,
Italy 39 02 41309277, Japan 0120-527196, Korea 82 02 3451 3400, Lebanon 961 (0) 1 33 28 28,
Malaysia 1800 887710, Mexico 01 800 010 0793, Netherlands 31 (0) 348 433 466,
New Zealand 0800 553 322, Norway 47 (0) 66 90 76 60, Poland 48 22 328 90 10,
Portugal 351 210 311 210, Russia 7 495 783 6851, Singapore 1800 226 5886,
Slovenia 386 3 425 42 00, South Africa 27 0 11 805 8197, Spain 34 91 640 0085,
Sweden 46 (0) 8 587 895 00, Switzerland 41 56 2005151, Taiwan 886 02 2377 2222,
Thailand 662 278 6777, Turkey 90 212 279 3031, United Kingdom 44 (0) 1635 523545

National Instruments, NI, ni.com, and LabVIEW are trademarks of National Instruments Corporation. Refer to the *Terms of Use* section on ni.com/legal for more information about National Instruments trademarks. Other product and company names mentioned herein are trademarks or trade names of their respective companies. For patents covering National Instruments products/technology, refer to the appropriate location: **Help»Patents** in your software, the `patents.txt` file on your media, or the *National Instruments Patent Notice* at ni.com/patents.