

TNT4882™ Evaluation Board Installation Guide

December 1993 Edition

Part Number 370873B-01

**© Copyright 1993-2005 National Instruments Corporation.
All Rights Reserved.**

National Instruments Corporate Headquarters

6504 Bridge Point Parkway

Austin, TX 78730-5039

(512) 794-0100

Technical support fax: (800) 328-2203

(512) 794-5678

Branch Offices:

Australia (03) 879 9422, Austria (0662) 435986, Belgium 02/757.00.20,

Canada (Ontario) (519) 622-9310, Canada (Québec) (514) 694-8521,

Denmark 45 76 26 00, Finland (90) 527 2321, France (1) 48 14 24 24,

Germany 089/741 31 30, Italy 02/48301892, Japan (03) 3788-1921,

Mexico 95 800 010 0793, Netherlands 03480-33466, Norway 32-84 84 00,

Singapore 2265886, Spain (91) 640 0085, Sweden 08-730 49 70,

Switzerland 056/20 51 51, Taiwan 02 377 1200, U.K. 0635 523545

Limited Warranty

The TNT4882 evaluation board is warranted against defects in materials and workmanship for a period of two years from the date of shipment, as evidenced by receipts or other documentation. National Instruments will, at its option, repair or replace equipment that proves to be defective during the warranty period. This warranty includes parts and labor.

The media on which you receive National Instruments software are warranted not to fail to execute programming instructions, due to defects in materials and workmanship, for a period of 90 days from date of shipment, as evidenced by receipts or other documentation. National Instruments will, at its option, repair or replace software media that do not execute programming instructions if National Instruments receives notice of such defects during the warranty period. National Instruments does not warrant that the operation of the software shall be uninterrupted or error free.

A Return Material Authorization (RMA) number must be obtained from the factory and clearly marked on the outside of the package before any equipment will be accepted for warranty work. National Instruments will pay the shipping costs of returning to the owner parts which are covered by warranty.

National Instruments believes that the information in this manual is accurate. The document has been carefully reviewed for technical accuracy. In the event that technical or typographical errors exist, National Instruments reserves the right to make changes to subsequent editions of this document without prior notice to holders of this edition. The reader should consult National Instruments if errors are suspected. In no event shall National Instruments be liable for any damages arising out of or related to this document or the information contained in it.

EXCEPT AS SPECIFIED HEREIN, NATIONAL INSTRUMENTS MAKES NO WARRANTIES, EXPRESS OR IMPLIED, AND SPECIFICALLY DISCLAIMS ANY WARRANTY OF MERCHANTABILITY OR FITNESS FOR A PARTICULAR PURPOSE. CUSTOMER'S RIGHT TO RECOVER DAMAGES CAUSED BY FAULT OR NEGLIGENCE ON THE PART OF NATIONAL INSTRUMENTS SHALL BE LIMITED TO THE AMOUNT THEREFORE PAID BY THE CUSTOMER. NATIONAL INSTRUMENTS WILL NOT BE LIABLE FOR DAMAGES RESULTING FROM LOSS OF DATA, PROFITS, USE OF PRODUCTS, OR INCIDENTAL OR CONSEQUENTIAL DAMAGES, EVEN IF ADVISED OF THE POSSIBILITY THEREOF. This limitation of the liability of National Instruments will apply regardless of the form of action, whether in contract or tort, including negligence. Any action against National Instruments must be brought within one year after the cause of action accrues. National Instruments shall not be liable for any delay in performance due to causes beyond its reasonable control. The warranty provided herein does not cover damages, defects, malfunctions, or service failures caused by owner's failure to follow the National Instruments installation, operation, or maintenance instructions; owner's modification of the product; owner's abuse, misuse, or negligent acts; and power failure or surges, fire, flood, accident, actions of third parties, or other events outside reasonable control.

Copyright

Under the copyright laws, this publication may not be reproduced or transmitted in any form, electronic or mechanical, including photocopying, recording, storing in an information retrieval system, or translating, in whole or in part, without the prior written consent of National Instruments Corporation.

Trademarks

TNT4882TM and TNT4882CTM are trademarks of National Instruments Corporation.

Product and company names listed are trademarks or trade names of their respective companies.

WARNING REGARDING MEDICAL AND CLINICAL USE OF NATIONAL INSTRUMENTS PRODUCTS

National Instruments products are not designed with components and testing intended to ensure a level of reliability suitable for use in treatment and diagnosis of humans. Applications of National Instruments products involving medical or clinical treatment can create a potential for accidental injury caused by product failure, or by errors on the part of the user or application designer. Any use or application of National Instruments products for or involving medical or clinical treatment must be performed by properly trained and qualified medical personnel, and all traditional medical safeguards, equipment, and procedures that are appropriate in the particular situation to prevent serious injury or death should always continue to be used when National Instruments products are being used. National Instruments products are NOT intended to be a substitute for any form of established process, procedure, or equipment used to monitor or safeguard human health and safety in medical or clinical treatment.

FCC/DOC Radio Frequency Interference Compliance

This equipment generates and uses radio frequency energy and, if not installed and used in strict accordance with the instructions in this manual, may cause interference to radio and television reception. This equipment has been tested and found to comply with the following two regulatory agencies:

Federal Communications Commission

This device complies with Part 15 of the Federal Communications Commission (FCC) Rules for a Class B digital device. A Class B device is distinguishable from a Class A device by the appearance of an FCC ID number located on the Class B device.

Canadian Department of Communications

This device complies with the limits for radio noise emissions from digital apparatus set out in the Radio Interference Regulations of the Canadian Department of Communications (DOC).

Le présent appareil numérique n'émet pas de bruits radioélectriques dépassant les limites applicables aux appareils numériques de classe B prescrites dans le règlement sur le brouillage radioélectrique édicté par le ministère des communications du Canada.

Instructions to Users

These regulations are designed to provide reasonable protection against interference from the equipment to radio and television reception in residential areas.

There is no guarantee that interference will not occur in a particular installation. However, the chances of interference are much less if the equipment is installed and used according to this instruction manual.

If the equipment does cause interference to radio or television reception, which can be determined by turning the equipment on and off, one or more of the following suggestions may reduce or eliminate the problem.

- Operate the equipment and the receiver on different branches of your AC electrical system.
- Move the equipment away from the receiver with which it is interfering.
- Reorient or relocate the receiver's antenna.
- Be sure that the equipment is plugged into a grounded outlet and that the grounding has not been defeated with a cheater plug.

Notice to user: Changes or modifications not expressly approved by National Instruments could void the user's authority to operate the equipment under the FCC Rules.

If necessary, consult National Instruments or an experienced radio/television technician for additional suggestions. The following booklet prepared by the FCC may also be helpful: *How to Identify and Resolve Radio-TV Interference Problems*. This booklet is available from the U.S. Government Printing Office, Washington, DC 20402, Stock Number 004-000-00345-4.

Contents

About This Manual	ix
How to Use the TNT4882 Reference Manuals.....	ix
Organization of This Manual.....	ix
Conventions Used in This Manual.....	x
Related Documentation	x
Customer Communication	xi
Chapter 1	
Introduction	1-1
How to Use This Manual	1-1
What You Need to Get Started	1-1
Hardware Description	1-2
Chapter 2	
Hardware Configuration and Installation	2-1
Install the Hardware.....	2-1
Configure the Hardware (Optional).....	2-3
Note to EISA Users	2-3
Hardware Default Settings	2-3
Selecting the Base I/O Address	2-4
Selecting the Interrupt Request Line	2-7
Selecting the DMA Channel	2-9
Using Programmed I/O for GPIB Transfers	2-10
Setting the Shield Ground Configuration	2-10
Chapter 3	
Installation Verification and Troubleshooting	3-1
Run the Hardware Diagnostic Program.....	3-1
Troubleshooting ibdiag Error Messages	3-1
Selecting Single-Cycle DMA	3-1
Correcting Hardware Settings	3-2
Appendix A	
Hardware Specifications	A-1
Appendix B	
Customer Communication	B-1
Glossary	G-1

Figures

Figure 2-1.	Installing the TNT4882 Evaluation Board	2-2
Figure 2-2.	TNT4882 Evaluation Board Parts Locator Diagram	2-4
Figure 2-3.	Base I/O Address Switch Settings	2-6
Figure 2-4.	Interrupt Jumper Setting for IRQ11 (Default Setting)	2-8
Figure 2-5.	Interrupt Jumper Setting for IRQ5	2-8
Figure 2-6.	Interrupt Jumper Setting for Disabling Interrupts	2-8
Figure 2-7.	DMA Channel Jumper Setting for DMA Channel 7	2-10
Figure 2-8.	DMA Jumper Setting for No DMA Channel	2-10
Figure 2-9.	Ground Configuration Jumper Settings.....	2-11

Tables

Table 2-1.	TNT4882 Evaluation Board Hardware Default Settings.....	2-3
Table 2-2.	Possible Base I/O Address Switch Settings.....	2-5
Table 2-3.	DMA Channels.....	2-9
Table A-1.	Electrical Characteristics	A-1
Table A-2.	Physical Characteristics	A-1
Table A-3.	Environmental Characteristics.....	A-2

About This Manual

This manual contains instructions to help you install and configure the National Instruments TNT4882 evaluation board. The TNT4882 evaluation board is intended for use in an ISA (PC AT) or compatible computer by developers of programmable instrumentation who are integrating the TNT4882 ASIC into their hardware design.

The National Instruments TNT4882 is the first single-chip IEEE 488.2 Talker/Listener (T/L) interface chip that you can use in all GPIB instrument designs. The 100-pin Quad Flat Pack (QFP) TNT4882 combines the circuitry of the National Instruments NAT4882 IEEE 488.2 interface ASIC, Turbo488 performance-enhancing ASIC, and GPIB transceivers to create a small, single-chip IEEE 488.2 solution. The TNT4882 also implements a new high-speed mode, called HS488, for GPIB transfers. HS488 increases the maximum transfer rate of GPIB up to 8 Mbytes/s, yet it is compatible with existing, non-HS488 instruments.

The TNT4882 evaluation board uses the ISA bus pin configuration of the TNT4882 ASIC. The TNT4882 evaluation board is similar to the National Instruments AT-GPIB/TNT board, but the TNT4882 evaluation board does not have Controller capability.

This manual assumes that you are already familiar with DOS.

How to Use the TNT4882 Reference Manuals

Use the *TNT4882 Evaluation Board Installation Guide* (part number 320726-01) to install and configure your TNT4882 hardware in an ISA computer.

Use the *TNT4882 Programmer Reference Manual* (part number 320724-01) for register bit descriptions and hardware design information.

Use the *ESP-488TL Software Reference Manual for TNT4882* (part number 320725-01) for specific information about each ESP-488 function and routine such as format, parameters, and possible errors.

Organization of This Manual

This manual is organized as follows:

- Chapter 1, *Introduction*, explains how to use this manual, lists what you need to get started, and includes a brief description of the TNT4882 evaluation board.
- Chapter 2, *Hardware Configuration and Installation*, contains instructions to help you configure and install your TNT4882 evaluation board.
- Chapter 3, *Installation Verification and Troubleshooting*, describes how to verify the hardware installation and how to troubleshoot problems.
- Appendix A, *Hardware Specifications*, describes the electrical, physical, and environmental characteristics of the TNT4882 evaluation board and the recommended operating conditions.
- Appendix B, *Customer Communication*, contains forms you can use to request help from National Instruments or to comment on our products and manuals.
- The *Glossary* contains an alphabetical list and a description of the terms that this manual uses, including abbreviations, acronyms, metric prefixes, mnemonics, and symbols.

Conventions Used in This Manual

This manual uses the following conventions.

<i>italic</i>	Italic text denotes emphasis, a cross reference, or an introduction to a key concept.
<i>bold italic</i>	Bold italic text denotes a note, caution, or warning.
monospace	Lowercase text in this font denotes text or characters that you literally input from the keyboard. This font also denotes file names, program names, and constants.
IEEE 488 and IEEE 488.2	IEEE 488 and IEEE 488.2 refer to the ANSI/IEEE Standard 488.1-1987 and ANSI/IEEE Standard 488.2-1987, respectively, which define the GPIB.

The *Glossary* lists abbreviations, acronyms, metric prefixes, mnemonics, symbols, and terms.

Related Documentation

The following documents contain information that you may find helpful as you read this manual.

- ANSI/IEEE Standard 488.1-1987, *IEEE Standard Digital Interface for Programmable Instrumentation*
- ANSI/IEEE Standard 488.2-1987, *IEEE Standard Codes, Formats, Protocols, and Common Commands*

Customer Communication

National Instruments wants to receive your comments on our products and manuals. We are interested in the applications you develop with our products, and we want to help if you have problems with them. To make it easy for you to contact us, this manual contains comment and configuration forms for you to complete. These forms are in Appendix B, *Customer Communication*, at the end of this manual.

Chapter 1

Introduction

This chapter explains how to use this manual, lists what you need to get started, and includes a brief description of the TNT4882 evaluation board.

How to Use This Manual

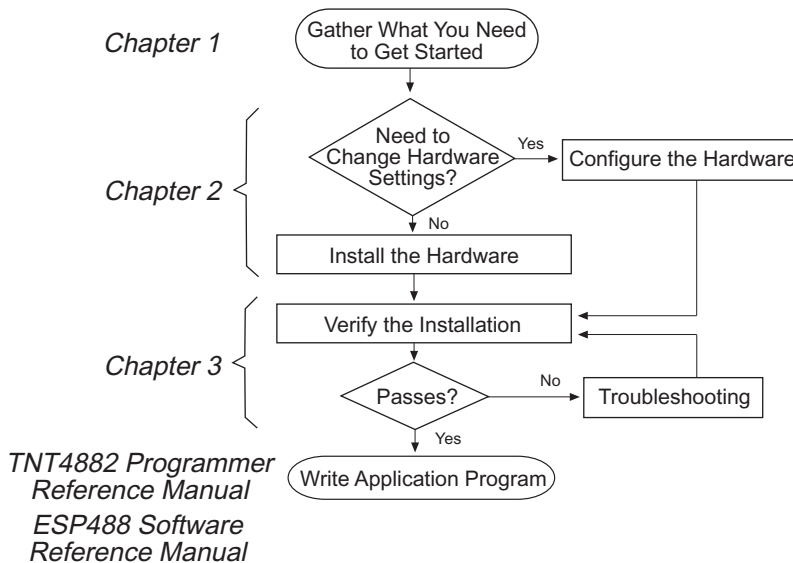

What You Need to Get Started

- TNT4882 evaluation board (part number 181830-03)
- EISA configuration and diagnostic disk for TNT4882 evaluation board (part number 413117-103)
- MS-DOS version 3.0 or higher (or equivalent) installed on your computer

Hardware Description

The TNT4882 evaluation board is intended to be used by developers of programmable instrumentation who are integrating the TNT4882 ASIC into their hardware design. The TNT4882 evaluation board uses the ISA bus pin configuration of the TNT4882 ASIC. Although it is similar to the AT-GPIB/TNT board, the TNT4882 evaluation board has only IEEE 488 T/L capability; the TNT4882 evaluation board does not have controller capability. Refer to Appendix A, *Hardware Specifications*, for more information about the hardware specifications and operating conditions of the TNT4882 evaluation board.

Chapter 2

Hardware Configuration and Installation

This chapter contains instructions to help you configure and install your TNT4882 evaluation board.

Warning: *Several components on your TNT4882 evaluation board can be damaged by electrostatic discharge. To avoid such damage when you handle the board, touch the antistatic plastic package to a metal part of your computer chassis before you remove the board from the package.*

The TNT4882 evaluation board default settings are suitable for most PC AT computer systems. However, if the default settings conflict with another device in your system or if you need to install more than one TNT4882 evaluation board, you must reconfigure the hardware. To modify the default settings of the TNT4882 evaluation board, go to the *Configure the Hardware* section of this chapter. If you do not need to reconfigure the board, go to the next section to install the hardware.

Install the Hardware

You can install the TNT4882 evaluation board in any 16-bit (AT-style) expansion slot or 8-bit (PC-style) slot in your computer. When you use an 8-bit slot, you must disable direct memory access (DMA) and use only interrupt request lines 3, 4, 5, 6, 7 or None. The *Configure the Hardware* section contains instructions to choose the appropriate hardware settings. Consult the user manual or technical reference manual of your personal computer for specific instructions and warnings.

Follow these steps to install the TNT4882 evaluation board:

1. Turn off your computer. Keep the computer plugged in so that it remains grounded while you install the TNT4882 evaluation board.
2. Remove the top cover or access port of the I/O channel.
3. Remove the expansion slot cover on the back panel of the computer.
4. Insert the TNT4882 evaluation board into any unused slot with the GPIB connector sticking out of the opening on the back panel, as shown in Figure 2-1. It may be a tight fit, but do not force the board into place.

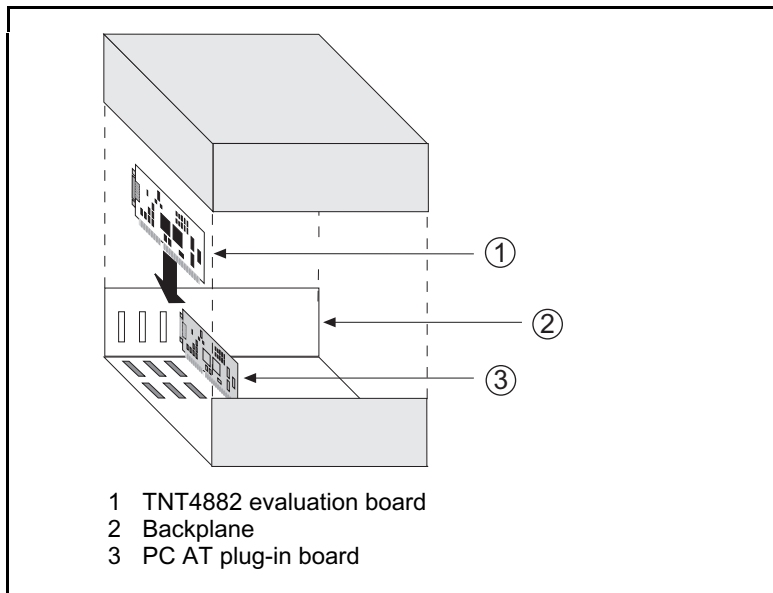

Figure 2-1. Installing the TNT4882 Evaluation Board

5. Screw the mounting bracket of the TNT4882 evaluation board to the back panel rail of the computer.
6. Check the installation.
7. Return the top cover or access port to the I/O channel.
8. Turn on your computer.

After you have installed your TNT4882 evaluation board, you are ready to verify the hardware installation as described in Chapter 3, *Installation Verification and Troubleshooting*.

Configure the Hardware (Optional)

Follow the instructions in this section to change the hardware default settings of the TNT4882 evaluation board.

Note to EISA Users

If you have an EISA bus-based computer, you can use the EISA configuration file included on the National Instruments EISA configuration and diagnostic disk, which came with your TNT4882 evaluation board. Follow the instructions that came with your computer to copy the !NICC403.CFG file to your EISA configuration disk. Your EISA configuration program uses the information in this configuration file to help you select appropriate settings for the GPIB hardware. After the program determines the settings, you must configure the DIP switches and jumpers on the GPIB hardware to match.

The GPIB board uses negative logic; the OFF position of the switch represents a logic one and the ON position represents a logic zero. As a result, some of the screens in your EISA configuration program might show a pattern of ones and zeroes that is exactly opposite of the correct way to set your switch. The screen will show a picture of the switch, a pattern of ones and zeroes, and a pattern of ONs and OFFs. The pattern of ONs and OFFs shown on the screen is correct. Set your DIP switches to match these ONs and OFFs. Do not use the picture of the switch or the pattern of ones and zeroes on the screen as your guide for setting the DIP switches.

Hardware Default Settings

Table 2-1 shows the default settings for the switches and jumpers on the TNT4882 evaluation board.

Table 2-1. TNT4882 Evaluation Board Hardware Default Settings

TNT4882 Setting	Default
Base I/O Address (hex)	2C0
DMA Channel	5
Interrupt Line (IRQ)	11

Figure 2-2 shows the location of the configuration jumpers and switches on the TNT4882 evaluation board.

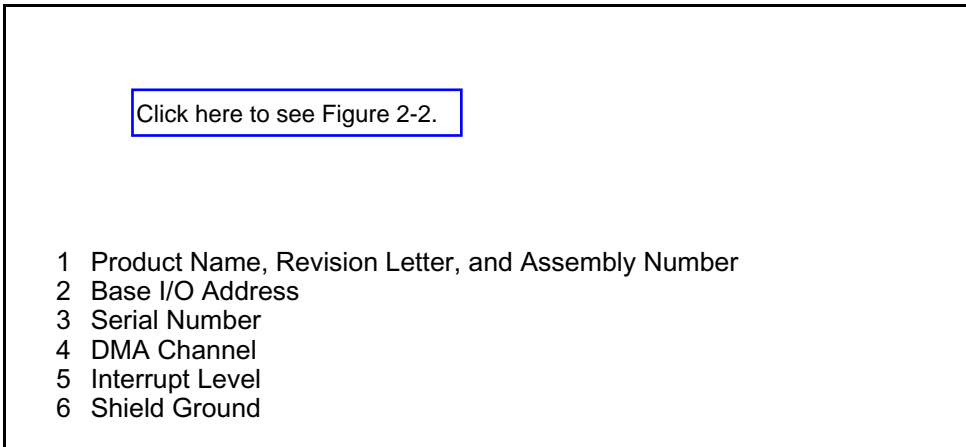

Figure 2-2. TNT4882 Evaluation Board Parts Locator Diagram

Selecting the Base I/O Address

PC AT computers have a segment of memory reserved for input and output. This segment is called the I/O address space. The base I/O address of a PC AT plug-in board such as the TNT4882 evaluation board is the first position in the I/O address space that the plug-in interface board occupies.

By default, the TNT4882 evaluation board is configured to use base I/O address 2C0 hex. With this setting, the TNT4882 evaluation board uses the I/O address space 2C0 hex through 2DF hex. If 2C0 hex is not an acceptable setting or if you are installing more than one board, follow these steps to reconfigure the base I/O address setting.

1. Choose a new base I/O address setting.

You can configure the base I/O addresses to any setting between 0x100 and 0x3E0 that is a multiple of 0x20 hex. If you are installing more than one TNT4882 evaluation board, you must make sure that each board uses a unique base I/O address.

Table 2-2 lists the possible switch settings, the corresponding base I/O addresses, and the I/O address space used for each setting.

Table 2-2. Possible Base I/O Address Switch Settings

Switch Setting					Base I/O Address (hex)	I/O Address Space Used (hex)
A9	A8	A7	A6	A5		
0	1	0	0	0	100	100 to 11F
0	1	0	0	1	120	120 to 13F
0	1	0	1	0	140	140 to 15F
0	1	0	1	1	160	160 to 17F
0	1	1	0	0	180	180 to 19F
0	1	1	0	1	1A0	1A0 to 1BF
0	1	1	1	0	1C0	1C0 to 1DF
0	1	1	1	1	1E0	1E0 to 1FF
1	0	0	0	0	200	200 to 21F
1	0	0	0	1	220	220 to 23F
1	0	0	1	0	240	240 to 25F
1	0	0	1	1	260	260 to 27F
1	0	1	0	0	280	280 to 29F
1	0	1	0	1	2A0	2A0 to 2BF
1	0	1	1	0	2C0	2C0 to 2DF
1	0	1	1	1	2E0	2E0 to 2FF
1	1	0	0	0	300	300 to 31F
1	1	0	0	1	320	320 to 33F
1	1	0	1	0	340	340 to 35F
1	1	0	1	1	360	360 to 37F
1	1	1	0	0	380	380 to 39F
1	1	1	0	1	3A0	3A0 to 3BF
1	1	1	1	0	3C0	3C0 to 3DF
1	1	1	1	1	3E0	3E0 to 3FF

2. Locate the base I/O address switch at SW1 on your TNT4882 evaluation board. Refer to Figure 2-2.
3. Change the switch settings to configure the TNT4882 evaluation board to the new base I/O address.

Press down on the side marked OFF to select a binary value of 1 for the corresponding address bit. Press down on the ON side to select a binary value of 0. Refer to Figure 2-3 for an example of the switch settings and corresponding base I/O addresses.

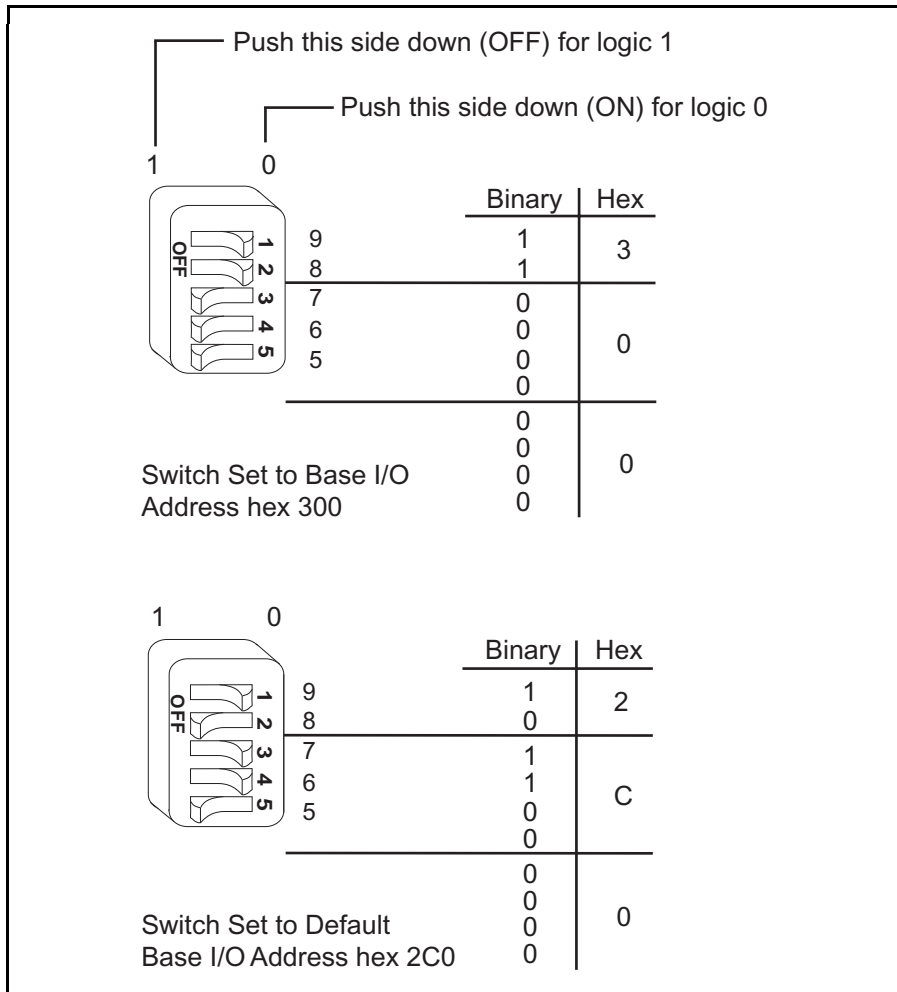

Figure 2-3. Base I/O Address Switch Settings

4. Record your new setting on the *TNT4882 Hardware Configuration Form* in Appendix B, *Customer Communication*.

Selecting the Interrupt Request Line

PC AT computers have a series of interrupt lines that are available to devices. Devices use interrupts to get immediate service from the CPU for asynchronous events. Your TNT4882 hardware uses interrupts to get service from the CPU when necessary.

By default, the TNT4882 evaluation board is configured to use interrupt request line (IRQ) 11. If this is not an acceptable setting or if you are installing more than one board, follow these steps to reconfigure the interrupt request:

1. Choose a new interrupt request line (IRQ) setting.

When you install the TNT4882 evaluation board in a 16-bit ISA slot, you can configure the TNT4882 evaluation board to use any of the following interrupt lines: IRQ3, 4, 5, 7, 9, 10, 11, 12, 15, or None. Do not use interrupt line 6 or interrupt line 14. Interrupt line 6 is used by the diskette drive controller and interrupt line 14 is used by the hard disk drive controller on most PC ATs.

If you have installed the TNT4882 evaluation board in an 8-bit (PC-style) slot, the only interrupt lines available to you are 3, 4, 5, 6, 7, or None.

When you install more than one TNT4882 evaluation board, you must make sure that each board either uses a unique IRQ level or does not use interrupts at all.

2. Find the jumpers that set the IRQ. The jumpers are located on the lower edge of your TNT4882 evaluation board.
3. Change the jumper settings to configure your TNT4882 evaluation board to the new IRQ.

To use lines 10, 11, 12, or 15, use the jumper block shown in Figure 2-4. To use interrupt lines 3, 4, 5, 7, or 9, use the jumper block shown in Figure 2-5. To disable interrupts, refer to Figure 2-6.

Figure 2-4 shows the setting for IRQ11.

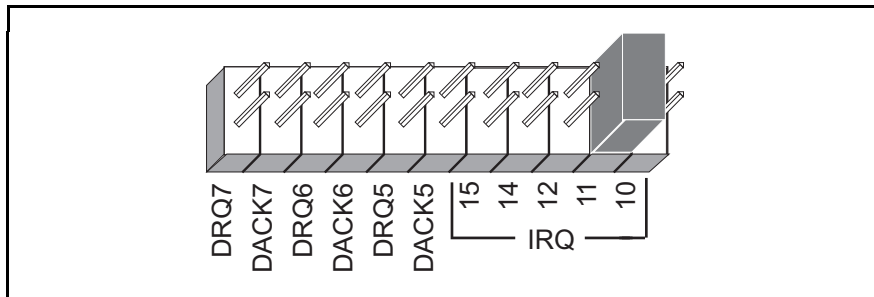

Figure 2-4. Interrupt Jumper Setting for IRQ11 (Default Setting)

Figure 2-5 shows the setting for IRQ5.

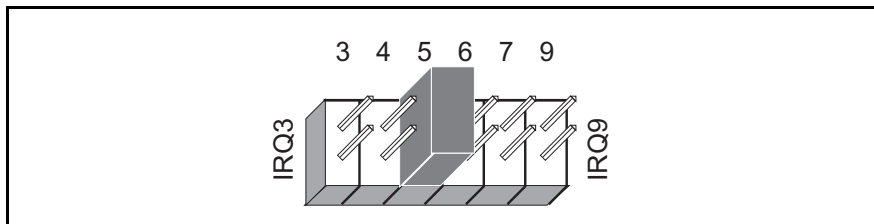

Figure 2-5. Interrupt Jumper Setting for IRQ5

If you do not want to use interrupts, you can disable interrupt levels on the TNT4882 evaluation board by moving the jumper, as shown in Figure 2-6.

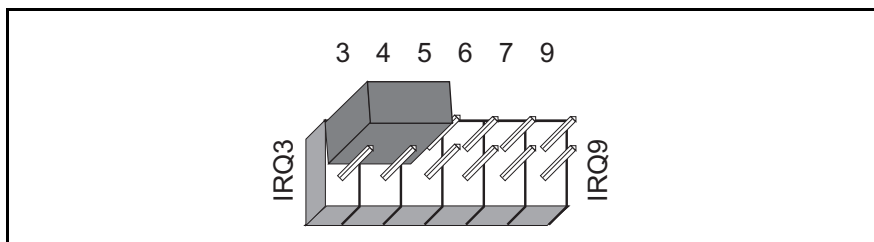

Figure 2-6. Interrupt Jumper Setting for Disabling Interrupts

4. Record your new setting on the *TNT4882 Hardware Configuration Form* in Appendix B, *Customer Communication*.

Selecting the DMA Channel

Direct memory access (DMA) refers to data transfers that are directly to or from devices such as the TNT4882 evaluation board and the computer memory. Your TNT4882 hardware is designed to perform DMA. In most cases, data transfers that use DMA are significantly faster than programmed I/O transfers, which use more CPU time. If you want to disable DMA and use programmed I/O transfers, go to the next section, *Using Programmed I/O for GPIB Transfers*.

By default, the TNT4882 evaluation board is configured to use DMA channel 5. If this is not an acceptable setting or if you are installing more than one board, follow these steps to reconfigure the DMA channel.

Note: *If you will install the TNT4882 evaluation board in an 8-bit (PC-style) slot, you must disable DMA, because DMA channels 5, 6, and 7 are 16-bit DMA channels. The TNT4882 evaluation board does not use and cannot be configured to use the 8-bit DMA channels on the PC AT I/O channel.*

1. Choose a new DMA channel setting.

You can use channel 5, 6, or 7. If you are installing more than one TNT4882 evaluation board, you must make sure that each board either uses a unique DMA channel or does not use DMA at all.

2. Locate the jumpers that set the DMA channel. Refer to Figure 2-2.
3. Change the jumper settings to configure the TNT4882 evaluation board to the new DMA channel. To select a new DMA channel, you must set both the DMA Acknowledge (DACK) and DMA Request (DRQ) lines, as shown in Table 2-3.

Table 2-3. DMA Channels

DMA Channel	Signal Lines	
	DMA Acknowledge	DMA Request
5	DACK5	DRQ5
6	DACK6	DRQ6
7	DACK7	DRQ7

Figure 2-7 shows the jumper position for selecting DMA channel 7.

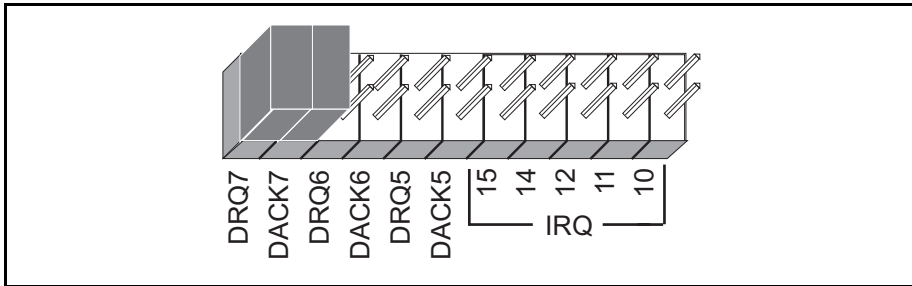

Figure 2-7. DMA Channel Jumper Setting for DMA Channel 7

- Record your new setting on the *TNT4882 Hardware Configuration Form* in Appendix B, *Customer Communication*.

Using Programmed I/O for GPIB Transfers

As an alternative to DMA transfers, you can use programmed I/O. To use programmed I/O, disable DMA for the TNT4882 evaluation board by moving the jumpers as shown in Figure 2-8.

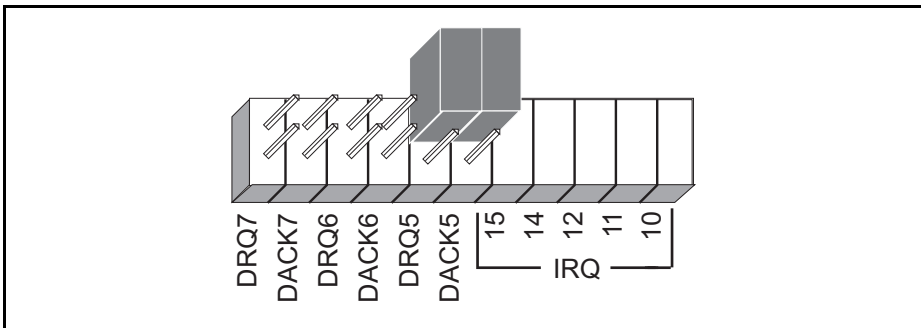

Figure 2-8. DMA Jumper Setting for No DMA Channel

Setting the Shield Ground Configuration

The TNT4882 evaluation board is set at the factory with the jumper in place to connect the logic ground of the TNT4882 evaluation board to its shield ground. This configuration minimizes EMI emissions.

Caution: *The TNT4882 evaluation board was tested for compliance with FCC standards with the shield ground connected to logic ground. Removing the jumper may cause EMI emissions to exceed any or all of the applicable standards.*

If your application requires that logic ground be disconnected from shield ground, follow these steps:

1. Refer to Figure 2-2 to locate the shield ground jumper W3.
2. Remove the jumper and place it across only one of the jumper pins, as shown in Figure 2-9.

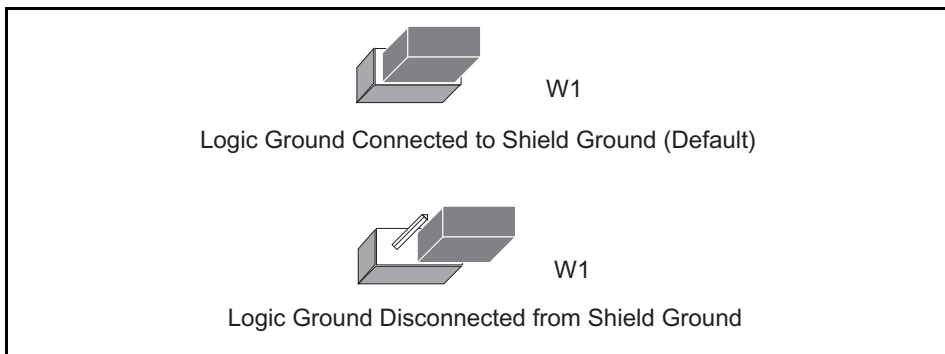

Figure 2-9. Ground Configuration Jumper Settings

3. Record the jumper setting on the *TNT4882 Hardware Configuration Form* in Appendix B, *Customer Communication*.

Now that you have properly configured the hardware, return to the *Install the Hardware* section at the beginning of this chapter for the installation instructions.

Chapter 3

Installation Verification and Troubleshooting

This chapter describes how to verify the hardware installation and how to troubleshoot problems.

Run the Hardware Diagnostic Program

To verify and test the hardware installation, run the `ibdiag` hardware diagnostic program. `ibdiag` verifies that your hardware is functioning properly and that the configuration of your board does not conflict with anything else in your system.

Follow these steps to run `ibdiag`:

1. Disconnect any GPIB cables.
2. Insert the EISA configuration and diagnostic disk and make that drive your default drive.
3. Enter the following command at the DOS prompt:

```
ibdiag
```

If `ibdiag` completes with no errors, your hardware is functioning properly. If `ibdiag` returns an error message, refer to the next section for troubleshooting instructions.

Troubleshooting `ibdiag` Error Messages

Verify that all GPIB cables are disconnected and that the switch and jumper settings on the hardware match the values you entered for `ibdiag`.

Selecting Single-Cycle DMA

The TNT4882 evaluation board normally uses demand-mode DMA. If `ibdiag` cannot use demand-mode DMA, it prints a message telling you to use single-cycle DMA. If this is the only error message, you do not need to continue troubleshooting `ibdiag`. You select single-cycle DMA by completing the following steps:

1. Open the `io_param.h` file on the ESP-488TL distribution disk.
2. Set the `USE_DEMAND_MODE_DMA` constant that is in the `io_param.h` file to `NO`. DMA transfers will now use single-cycle DMA.

Correcting Hardware Settings

Follow these steps to troubleshoot `ibdiag` error messages.

1. Make sure you are using a valid base I/O address.

Run `ibdiag` again. When it prompts you for values, enter your base I/O address, but enter 0 for both the interrupt request line and the DMA channel. If `ibdiag` fails again, one of the following situations is occurring:

- The base address that you entered at the `ibdiag` prompt does not match the switch settings of the board. Check the switch settings again.
- A GPIB cable is connected to the board. Remove all GPIB cables before running `ibdiag` again.
- Another board or built-in device in your computer is using the same address space. Change the base I/O address of your TNT4882 evaluation board and repeat this step using the new setting.
- The board is defective or cannot run in your computer. Complete the *Technical Support Form* in Appendix B, *Customer Communication*, and contact National Instruments.

2. Make sure you are using a valid interrupt request line.

Run `ibdiag` again. When it prompts you for values, enter the valid base I/O address as determined in Step 1, the interrupt request line, and 0 for the DMA channel. If `ibdiag` fails, one of the following situations is occurring:

- The interrupt request line that you entered at the `ibdiag` prompt does not match the jumper setting of the board. Check the jumper setting again.
- Another board or built-in device in your computer is using the same interrupt request line. Change the interrupt request line of the TNT4882 evaluation board and repeat this step using the new setting.
- The board is defective or cannot run in your computer. Complete the *Technical Support Form* in Appendix B, *Customer Communication*, and contact National Instruments.

3. Make sure you are using a valid DMA channel.

Run `ibdiag` again. When it prompts you for values, enter the valid base I/O address and interrupt request line as determined in Steps 1 and 2, then enter the current DMA channel. If `ibdiag` fails, one of the following situations is occurring:

- The DMA channel that you entered at the `ibdiag` prompt does not match the jumper setting of the board. Check the jumper setting again.
- Another board or built-in device in your computer is using the same DMA channel. Change the DMA channel of the TNT4882 evaluation board and repeat this step using the new setting.
- The board is defective or cannot run in your computer. Complete the *Technical Support Form* in Appendix B, *Customer Communication*, and contact National Instruments.

Appendix A

Hardware Specifications

This appendix describes the electrical, physical, and environmental characteristics of the TNT4882 evaluation board and the recommended operating conditions.

Table A-1. Electrical Characteristics

Characteristic	Specification
Transfer Rates 3-wire (IEEE 488.1)	1.5 Mbytes/s*
High Speed (HS488) In ISA computer In EISA computer	1.5 Mbytes/s* 3.4 Mbytes/s*
Power Requirement (from PC/AT I/O channel)	+5 VDC 50 mA Typical 120 mA Maximum
* Actual speed may vary considerably from speeds shown, because of system and instrumentation capabilities.	

Table A-2. Physical Characteristics

Characteristic	Specification
Dimensions	10.67 cm by 16.51 cm (4.2 in. by 6.5 in.)
I/O Connector	IEEE 488 Standard 24-pin

Table A-3. Environmental Characteristics

Characteristic	Specification
Operating Environment Component Temperature Relative Humidity	0° to 40° C 10% to 90%, noncondensing
Storage Environment Temperature Relative Humidity	-20° to 70° C 5% to 90%, noncondensing
EMI	FCC Class B Certified

Appendix B

Customer Communication

For your convenience, this appendix contains forms to help you gather the information necessary to help us solve technical problems you might have as well as a form you can use to comment on the product documentation. Filling out a copy of the *Technical Support Form* before contacting National Instruments helps us help you better and faster.

National Instruments provides comprehensive technical assistance around the world. In the U.S. and Canada, applications engineers are available Monday through Friday from 8:00 a.m. to 6:00 p.m. (central time). In other countries, contact the nearest branch office. You may fax questions to us at any time.

Corporate Headquarters

(512) 795-8248

Technical support fax: (800) 328-2203
(512) 794-5678

Branch Offices	Phone Number	Fax Number
Australia	(03) 879 9422	(03) 879 9179
Austria	(0662) 435986	(0662) 437010-19
Belgium	02/757.00.20	02/757.03.11
Denmark	45 76 26 00	45 76 71 11
Finland	(90) 527 2321	(90) 502 2930
France	(1) 48 14 24 00	(1) 48 14 24 14
Germany	089/741 31 30	089/714 60 35
Italy	02/48301892	02/48301915
Japan	(03) 3788-1921	(03) 3788-1923
Mexico	95 800 010 0793	95 800 010 0793
Netherlands	03480-33466	03480-30673
Norway	32-848400	32-848600
Singapore	22658862265887	
Spain	(91) 640 0085	(91) 640 0533
Sweden	08-730 49 70	08-730 43 70
Switzerland	056/20 51 51	056/20 51 55
Taiwan	02 377 1200	02 737 4644
U.K.	0635 523545	0635 523154

Technical Support Form

Technical support is available at any time by fax. Include the information from your configuration form. Use additional pages if necessary.

Name _____

Company _____

Address _____

Fax (____) _____ Phone (____) _____

Computer brand _____

Model _____ Processor _____

Operating system _____

Speed _____MHz RAM _____MB

Display adapter _____

Mouse _____yes _____no

Other adapters installed _____

Hard disk capacity _____MB Brand _____

Instruments used _____

National Instruments hardware product model _____

Revision _____

Configuration _____

(continues)

The problem is _____

List any error messages _____

The following steps will reproduce the problem _____

TNT4882 Hardware Configuration Form

Record the settings and revisions of your hardware and software on the line to the right of each item. Update this form each time you revise your software or hardware configuration, and use this form as a reference for your current configuration.

National Instruments Products

- Software Revision Number on Disk _____
- TNT4882 Evaluation Board Revision _____
- Number of TNT4882 Boards in System _____
- Board Settings:

Base I/O Address	Interrupt Level	DMA Channel
_____	_____	_____
_____	_____	_____
_____	_____	_____
_____	_____	_____

- Shield Ground Connected to Logic Ground (Yes or No) _____

Other Products

- Computer Make and Model _____
- Microprocessor _____
- Clock Frequency _____
- Type of Monitor Card Installed _____
- Software Name and Version _____
- Application Programming Language (BASIC, C, Pascal, and so on) _____
- Other Boards in System _____

Glossary

Prefix	Meaning	Value
c-	cent-	10^2
m-	milli-	10^{-3}
M-	mega-	10^6

°	degrees
%	percent
A	amperes
ANSI	American National Standards Institute
ASIC	application-specific integrated circuit
C	Celsius
CPU	central processing unit
DACK	DMA Acknowledge
DMA	direct memory access
DRQ	DMA Request
DIP	dual inline package
EISA	Extended Industry Standard Architecture
EMI	electromagnetic interference
ESP	Engineering Software Package
FCC	Federal Communications Commission
GPIO	General Purpose Interface Bus
hex	hexadecimal
Hz	hertz
IEEE	Institute of Electrical and Electronic Engineers
in.	inches
I/O	input/output
IRQ	interrupt line
ISA	Industry Standard Architecture
m	meters
MB	megabytes of memory
Mbytes	1,000,000 bytes
PC	personal computer
QFP	Quad Flat Pack
RAM	random-access memory
s	seconds
T/L	Talker/Listener
VDC	volts direct current

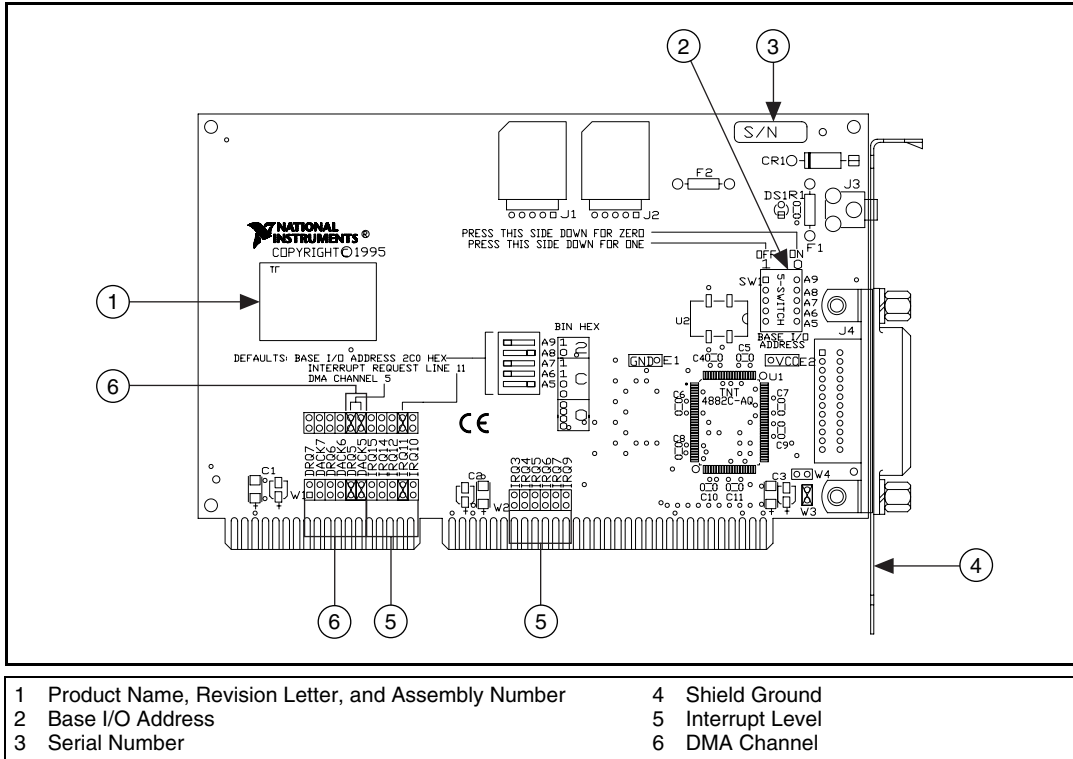

Figure 2-2. TNT4882 Evaluation Board Parts Locator Diagram