

SCXI-1181K Custom Module Assembly

This guide documents the contents of your SCXI-1181K custom module assembly kit and includes illustrations of the circuit board specifications and the module assembly.

Introduction

The SCXI-1181K custom module assembly kit includes the unassembled components you need to build a custom SCXI module, but not the actual circuit board. All of the mechanical components of an SCXI module, such as the metal enclosure, front and back panels, and connectors, are included.

The SCXI-1181K is intended for developers of custom SCXI modules who design and lay out custom circuit boards for modules. For prototyping or building low-volume custom SCXI modules, the fully assembled SCXI-1181 breadboard module is more appropriate.

What Your Kit Should Contain

The SCXI-1181K custom module assembly kit (part number 776572-81K) contains the components listed in the following table. The reference numbers in the left column of the table refer to callouts in Figure 1.

Reference Number	Component	Quantity
1	Module front panel	1
2	Module front panel overlay	1
3	Thumb screw, 2.5 mm	2
4	#4 x 5/16 in. Phillips screw, flat head	2
5	Enclosure base	1
6	Module rear panel	1
7	#4 x 5/16 in. Phillips screw, pan head	3
8	Enclosure cover	1
9	Identification label	1
J1	3 x 32 position Deutsche Industrie Norme connector header	1
J2	50 position connector header	1
P1	4 x 6, 2 mm connector, push-fit	4
—	Installation guide	1

Refer to the reference numbers of the components in the previous table and the corresponding components in Figure 1 for module assembly.

Note: *The four P1 connectors have a push-fit peg. Secure the P1 connectors to the printed wire circuit board (PWB) by pushing the connector onto the PWB so that the middle peg of the connector presses into the 0.081 in. hole in the PWB. National Instruments recommends using the push-fit peg hand tool (part number CTHT-200) manufactured by ITT Cannon for this installation. You can contact ITT Cannon at (800) 845-7000.*

Figure 2 shows the SCXI module PWB outline.

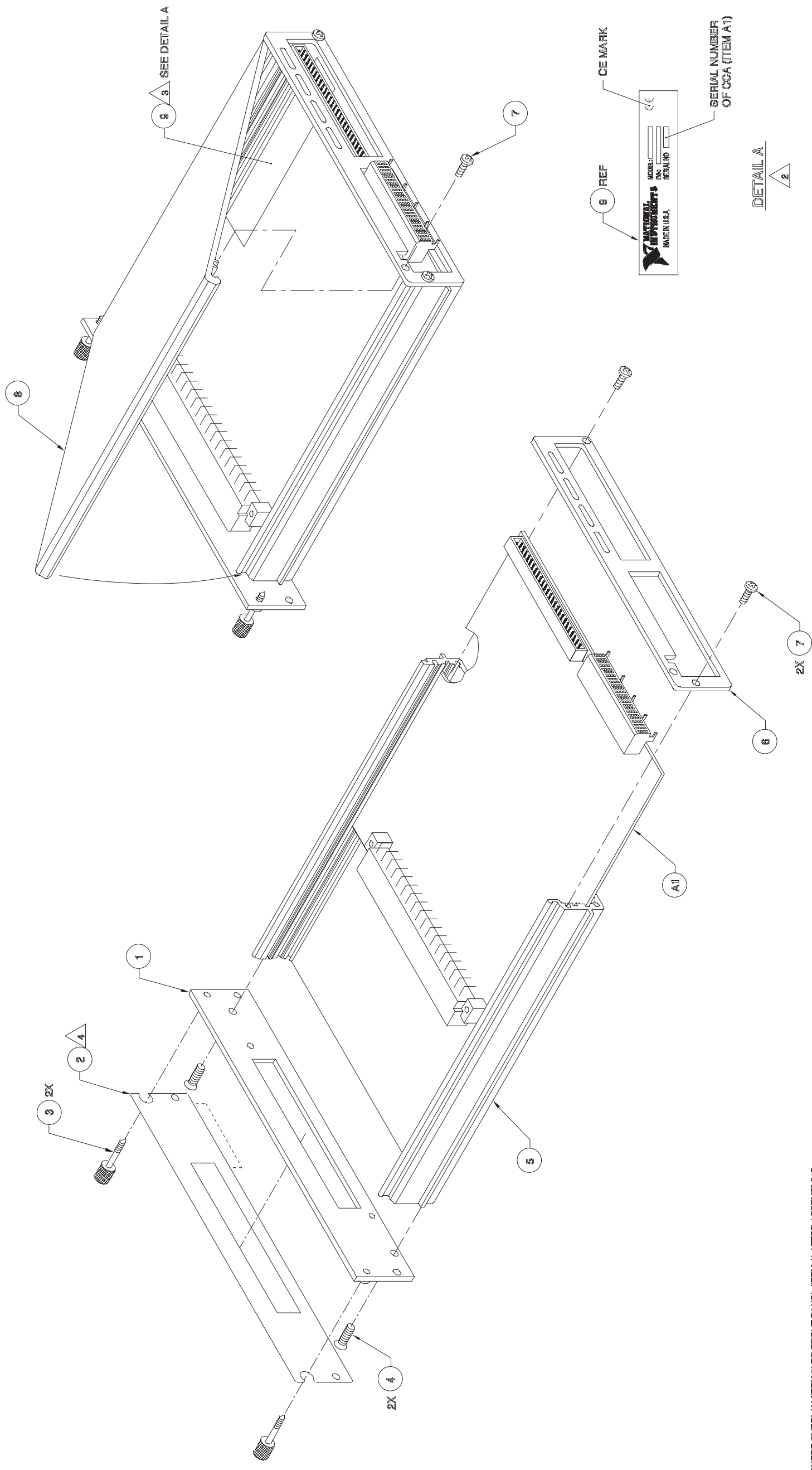

- ▲ 4 ADHERE OVERLAY (ITEM 2) TO FRONT PANEL (ITEM 1) AFTER ASSEMBLING FRONT PANEL TO BASE (ITEM 4).
 - ▲ 3 ADHERE LABEL (ITEM 9) TO OUTSIDE OF ENCLOSURE BASE (ITEM 6), IN LOCATION SHOWN WITH NI LOGO TO THE TOP OF THE MODULE, APPROXIMATELY .25 (B-4) FROM REAR PANEL (ITEM 6).
 - ▲ 2 MARK LABEL (ITEM 9) AS SHOWN IN DETAIL A, USING PERMANENT BLACK INK.
- 1 ASSEMBLE PER PARTS LIST.

NOTES: UNLESS OTHERWISE SPECIFIED,

Figure 1. Module Assembly Reference

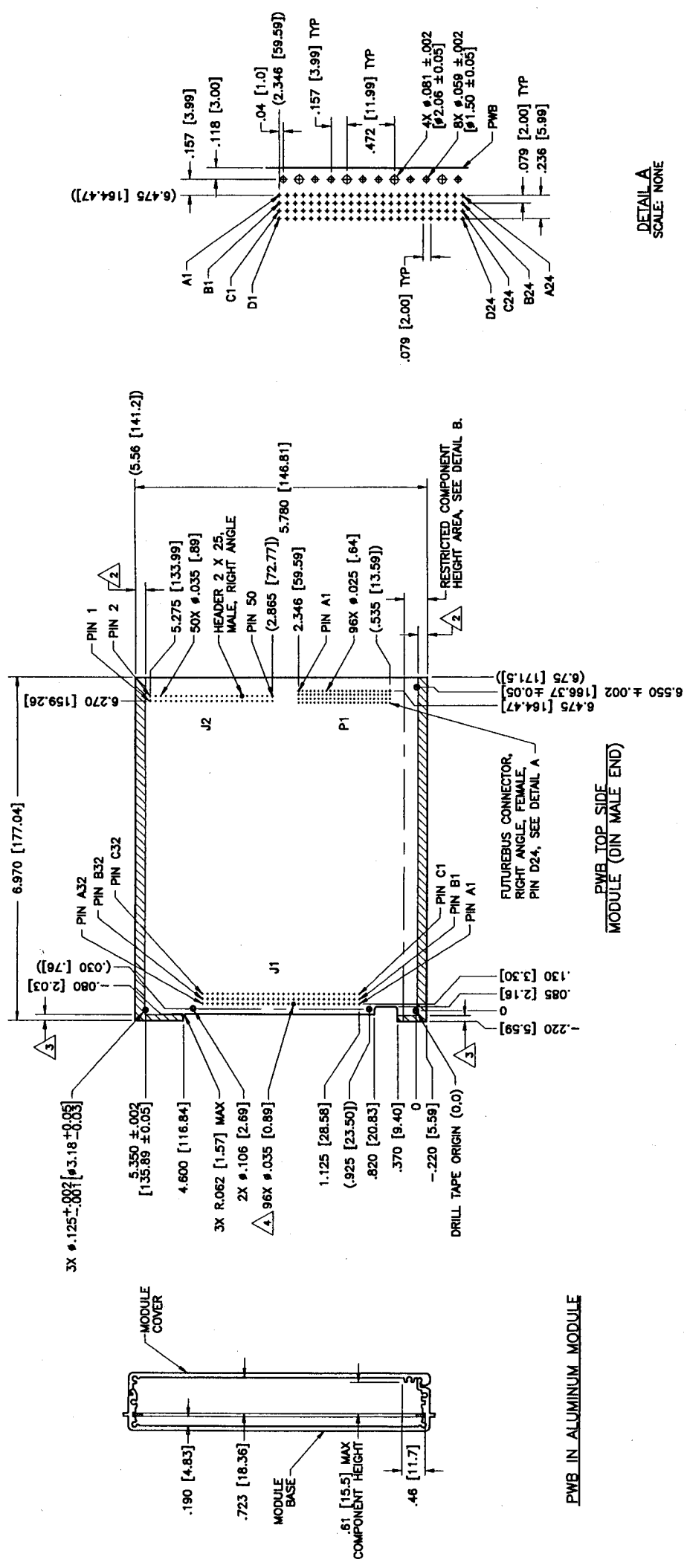

PWB IN ALUMINUM MODULE

PWB TOP SIDE MODULE (DIN MALE END)

DETAIL A SCALE: NONE

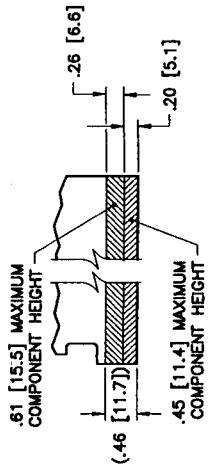

DETAIL B

- 1. DIMENSIONS IN () ARE FOR REFERENCE ONLY.
- 2. .025 [.64] KEEP-OUT FOR LOW VOLTAGE INNER LAYERS.
- 3. .040 [1.02] KEEP-OUT FOR HIGH VOLTAGE INNER LAYERS.
- 4. .025 [.64] KEEP-OUT FOR LOW VOLTAGE TRACES AND COMPONENTS.
- 5. .120 [3.05] KEEP-OUT FOR 250V TRACES AND COMPONENTS.
- 6. .180 [4.57] KEEP-OUT FOR 450V TRACES AND COMPONENTS.
- 7. .025 [.64] KEEP-OUT FOR LOW VOLTAGE INNER LAYERS.
- 8. .040 [1.02] KEEP-OUT FOR HIGH VOLTAGE INNER LAYERS.
- 9. .100 [2.54] KEEP-OUT FOR LOW VOLTAGE TRACES AND COMPONENTS.
- 10. .195 [4.95] KEEP-OUT FOR 250V TRACES AND COMPONENTS.
- 11. .255 [6.46] KEEP-OUT FOR 450V TRACES AND COMPONENTS.

NOTES: UNLESS OTHERWISE SPECIFIED.

Figure 2. SCXI Module PWB Outline