



68-Pin Mating Connector and Shell Installation Guide

Part Number 320699-01

This guide describes how to assemble the 68-pin mating connector and shell. In addition to the 68-pin mating connector and shell kit contents, you need a National Instruments plug-in board with a 68-pin I/O connector and a cable.

Introduction

The 68-pin mating connector and shell consists of a backshell kit and a 68-pin female connector that mates to any plug-in board with a 68-pin male connector.

What Your Kit Should Contain

The contents of the 68-pin mating connector and shell kit are as follows:

Kit Component	Part Number
68-pin receptacle SCSI-II connector, solder type	760803-01
Backshell kit	760804-01
<i>68-Pin Mating Connector and Shell Installation Guide</i>	320699-01

If your kit is missing any components, contact National Instruments.

Assembly Procedure

First solder the cable wires to the appropriate connector pins, shown in Figure 1, which illustrates the soldering side of the connector. Position the connector in the bottom half of the shell.

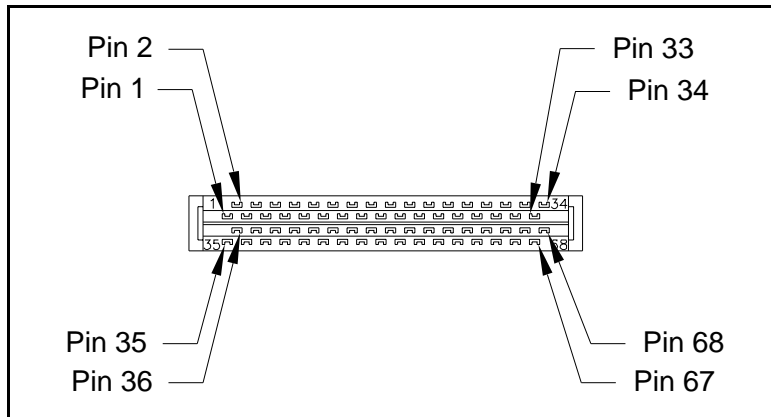

Figure 1. Connector Solder Side

Follow the remaining steps shown in Figure 2 to assemble the mating connector and shell.

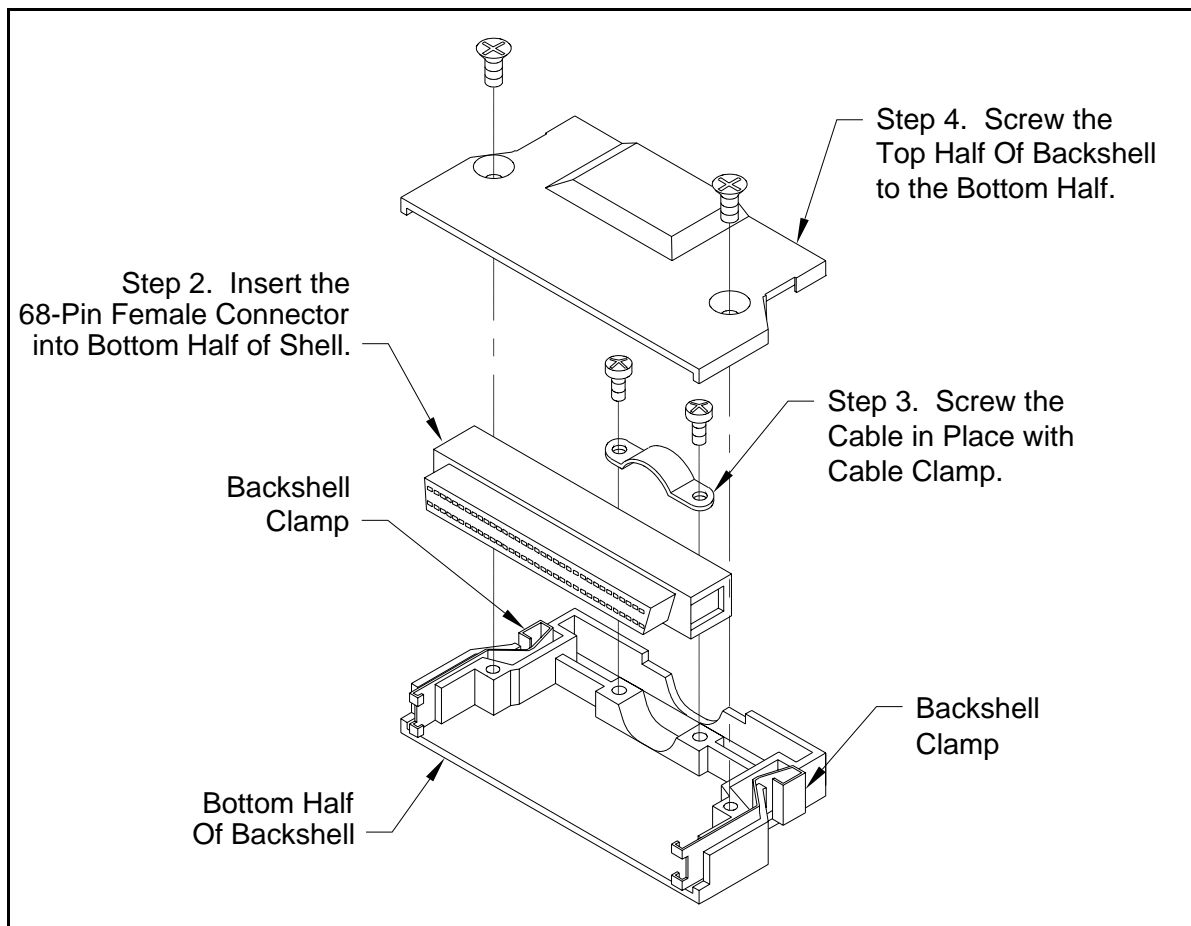

Figure 2. Component Assembly

Note: To disconnect the cable from the plug-in board, squeeze the backshell clamps and pull.