

This guide contains the product specifications for the GPIB-232CV-A and GPIB-232CT-A OEM products. It also contains the critical measurements that are necessary for you to design an enclosure or properly mount the product.

Product Description

The GPIB-232CV-A and GPIB-232CT-A OEM perform the same functions as the standard GPIB-232CV-A and GPIB-232CT-A, but are intended for use in custom applications. For documentation on the functionality of the GPIB-232CV-A and GPIB-232CT-A, refer to the following National Instruments user manuals:

GPIB-232CV-A User Manual

GPIB-232CT-A User Manual

Product Specifications

The following tables describe the power requirements and the physical and environmental characteristics of the GPIB-232CV-A and GPIB-232CT-A OEM products.

Table 1. Power Requirements

Characteristic	Specification
5VDC +/- 10%	280 mA typical 400 mA maximum

Table 2. Physical Characteristics

Characteristic	Specification
Dimension PWB	2.70 in. by 4.45 in. (6.858 cm by 11.303 cm)
Overall	2.76 in. by 5.17 in. by 0.86 in. (7.010 cm by 13.132 cm by 2.184 cm)

(continues)

Table 2. Physical Characteristics (Continued)

Characteristic	Specification
Weight	3 oz. (85.05 grams)
I/O connectors	
GPIB port	IEEE 488 standard 24-pin
RS-232 port	Standard 9-pin male D-subminiature

Table 3. Environmental Characteristics

Characteristic	Specification
Operating Environment	
Temperature	0° to 40° C
Relative Humidity	10% to 90%, noncondensing
Storage Environment	
Temperature	-20° to 70° C
Relative Humidity	10% to 90%, noncondensing

Parts Locator Diagrams

Figure 1 shows the locations of the components on the top side of the circuit card assembly. Notice that according to Figure 1, you hook up power at W1 on the circuit card assembly. W1 consists of two .035 in. holes spaced at .2 in. centers. These holes accept either .025 in. square posts or 20 to 22 AWG wire.

Figure 2 shows the locations of the components on the bottom side of the circuit card assembly as well as the function of each LED.

Mechanical Diagrams

Note: *Dimensions are given in inches.*

Figure 3 shows the hole and component placement. Use this information as a guide to properly mount the circuit card assembly.

Figure 4 consists of four smaller figures that show the dimensions of the connectors, switches, and LEDs. These dimensions help you determine the proper clearance around these components when you design an enclosure.

Figure 5 contains the height requirements that you need to accommodate to properly mount the circuit card assembly inside an enclosure.

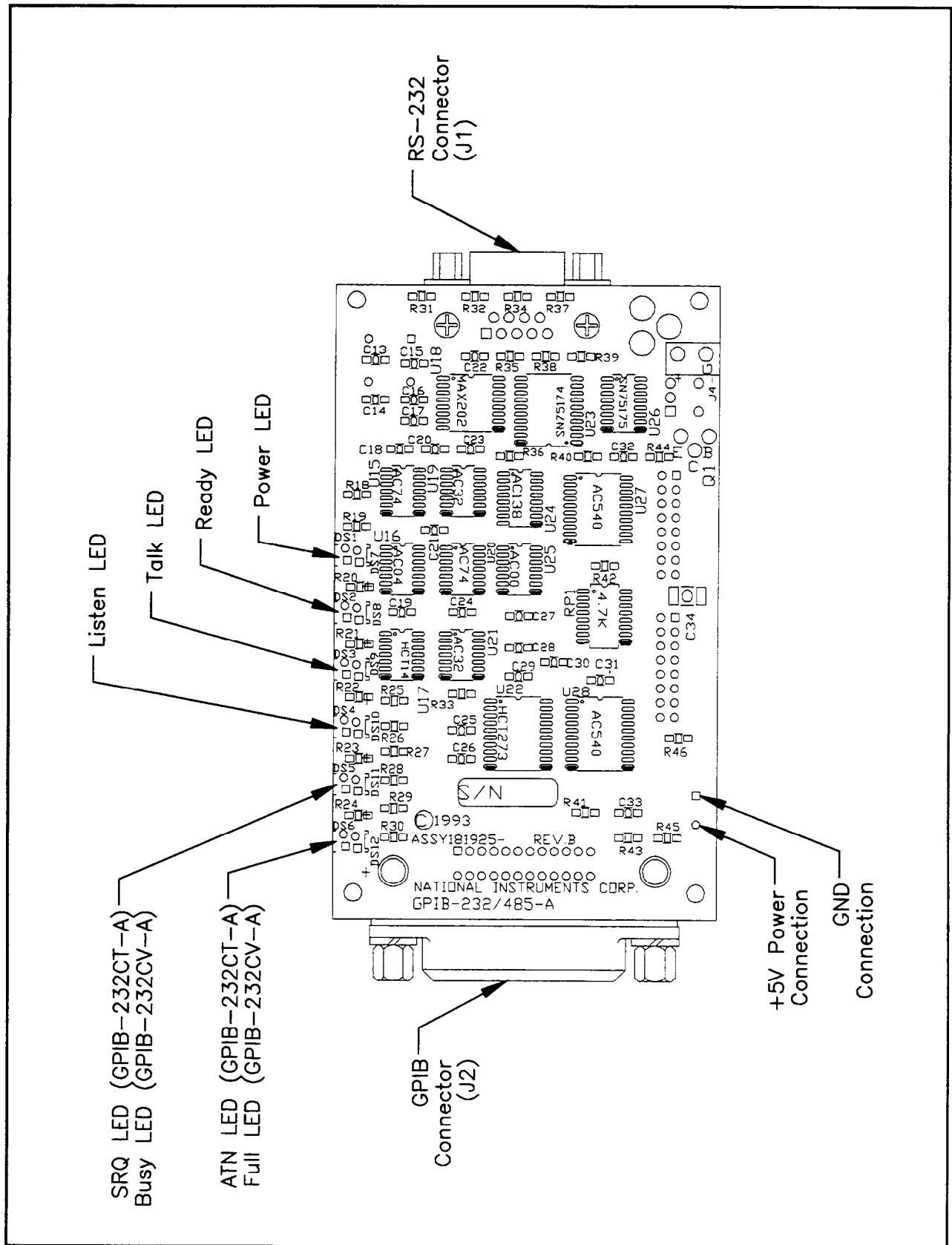

Figure 1. Component on the Top Side of the Circuit Card Assembly

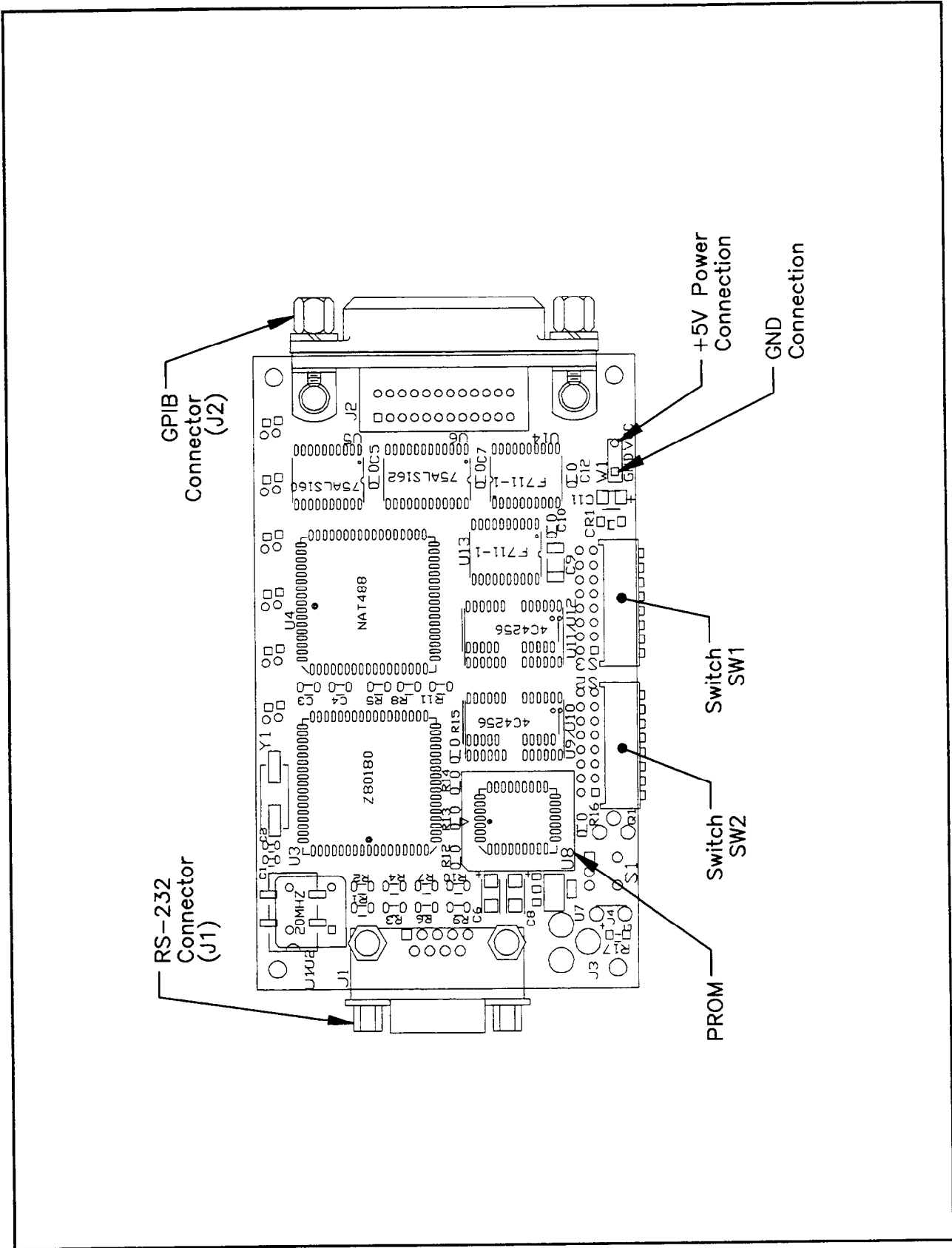

Figure 2. Component on the Bottom Side of the Circuit Card Assembly

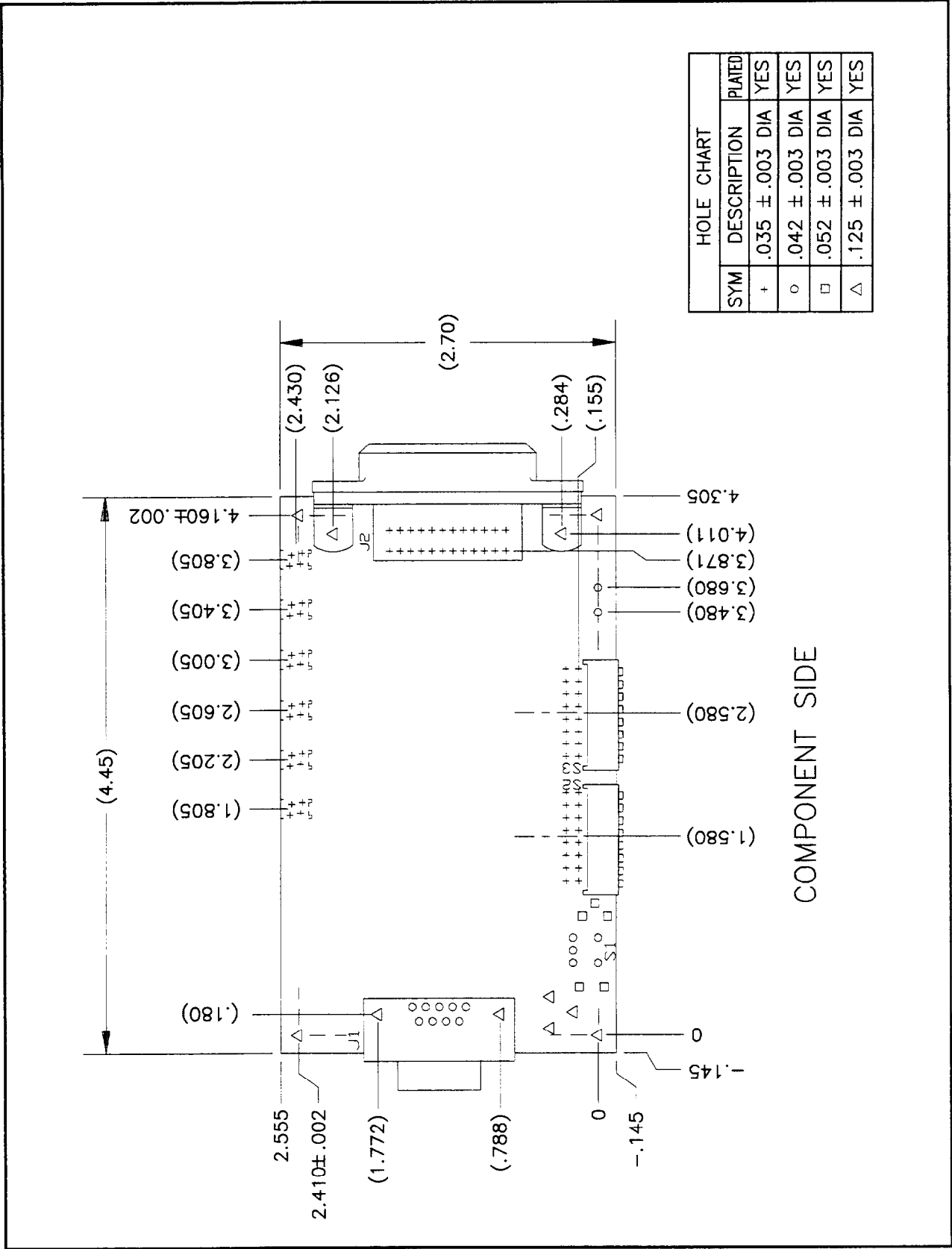

Figure 3. Hole and Component Placement

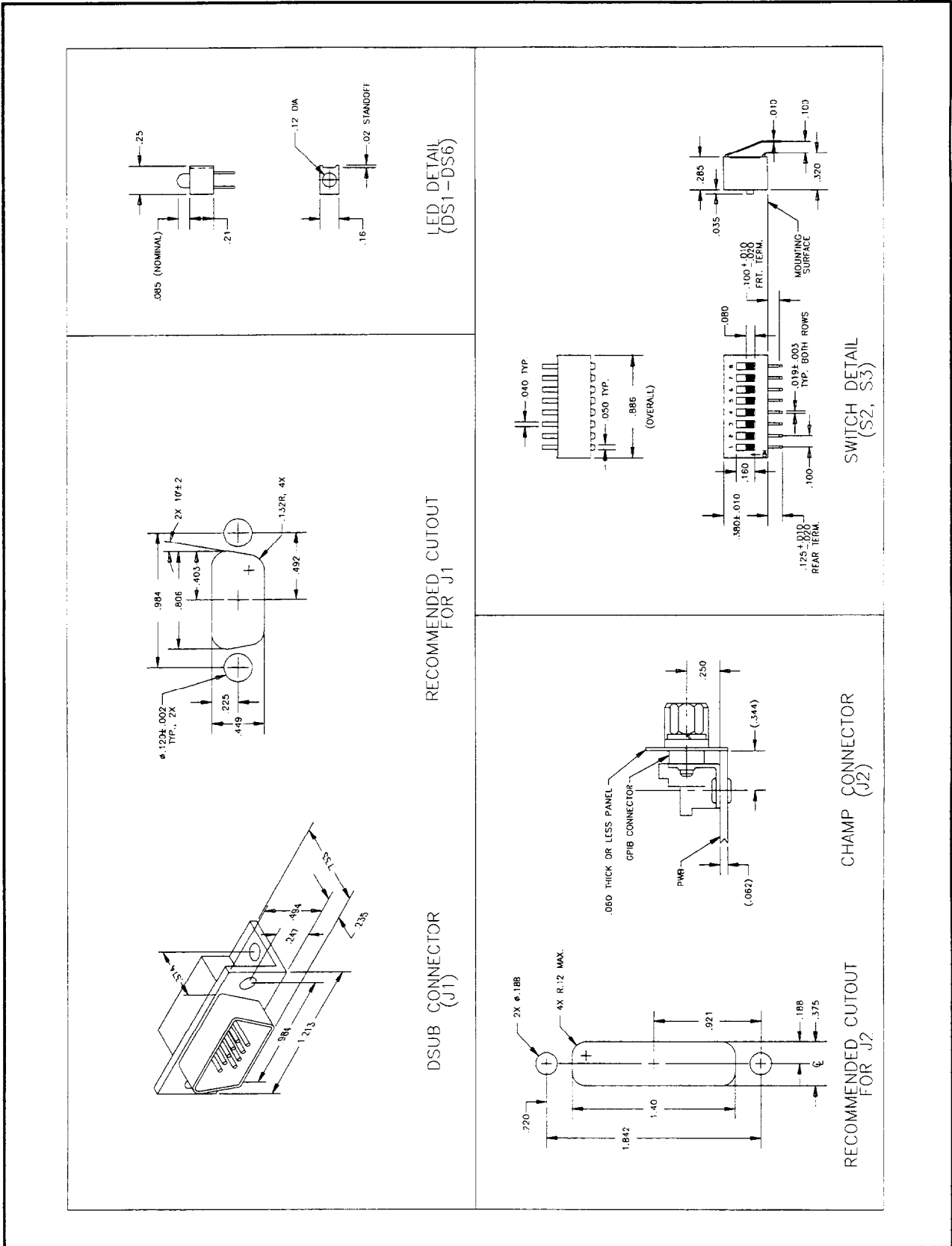

Figure 4. Measurements for Mounting Connectors, Switches, and LEDs

HEIGHT REQUIREMENTS

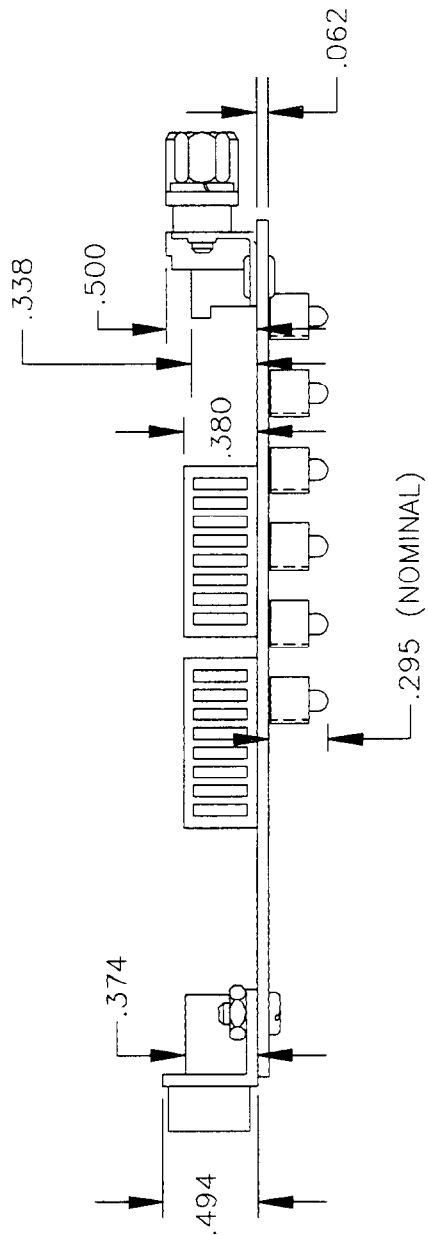

Figure 5. Height Requirements