

SCXI-1160

User Manual

16-Channel Single-Pole Double-Throw (SPDT) Relay Module

March 1994 Edition

Part Number 320513-01

**© Copyright 1992, 1994 National Instruments Corporation.
All Rights Reserved.**

National Instruments Corporate Headquarters

6504 Bridge Point Parkway

Austin, TX 78730-5039

(512) 794-0100

Technical support fax: (512) 794-5678

Branch Offices:

Australia 03 879 9422, Austria 0662 435986, Belgium 02 757 00 20, Canada (Ontario) 519 622 9310,

Canada (Québec) 514 694 8521, Denmark 45 76 26 00, Finland 90 527 2321, France 1 48 65 33 70,

Germany 089 714 50 93, Italy 02 48301892, Japan 03 3788 1921, Netherlands 01720 45761, Norway 03 846866,

Spain 91 640 0085, Sweden 08 730 49 70, Switzerland 056 27 00 20, U.K. 0635 523545

Limited Warranty

The SCXI-1160 is warranted against defects in materials and workmanship for a period of one year from the date of shipment, as evidenced by receipts or other documentation. National Instruments will, at its option, repair or replace equipment that proves to be defective during the warranty period. This warranty includes parts and labor.

A Return Material Authorization (RMA) number must be obtained from the factory and clearly marked on the outside of the package before any equipment will be accepted for warranty work. National Instruments will pay the shipping costs of returning to the owner parts which are covered by warranty.

National Instruments believes that the information in this manual is accurate. The document has been carefully reviewed for technical accuracy. In the event that technical or typographical errors exist, National Instruments reserves the right to make changes to subsequent editions of this document without prior notice to holders of this edition. The reader should consult National Instruments if errors are suspected. In no event shall National Instruments be liable for any damages arising out of or related to this document or the information contained in it.

EXCEPT AS SPECIFIED HEREIN, NATIONAL INSTRUMENTS MAKES NO WARRANTIES, EXPRESS OR IMPLIED, AND SPECIFICALLY DISCLAIMS ANY WARRANTY OF MERCHANTABILITY OR FITNESS FOR A PARTICULAR PURPOSE. CUSTOMER'S RIGHT TO RECOVER DAMAGES CAUSED BY FAULT OR NEGLIGENCE ON THE PART OF NATIONAL INSTRUMENTS SHALL BE LIMITED TO THE AMOUNT THERETOFORE PAID BY THE CUSTOMER. NATIONAL INSTRUMENTS WILL NOT BE LIABLE FOR DAMAGES RESULTING FROM LOSS OF DATA, PROFITS, USE OF PRODUCTS, OR INCIDENTAL OR CONSEQUENTIAL DAMAGES, EVEN IF ADVISED OF THE POSSIBILITY THEREOF. This limitation of the liability of National Instruments will apply regardless of the form of action, whether in contract or tort, including negligence. Any action against National Instruments must be brought within one year after the cause of action accrues. National Instruments shall not be liable for any delay in performance due to causes beyond its reasonable control. The warranty provided herein does not cover damages, defects, malfunctions, or service failures caused by owner's failure to follow the National Instruments installation, operation, or maintenance instructions; owner's modification of the product; owner's abuse, misuse, or negligent acts; and power failure or surges, fire, flood, accident, actions of third parties, or other events outside reasonable control.

Copyright

Under the copyright laws, this publication may not be reproduced or transmitted in any form, electronic or mechanical, including photocopying, recording, storing in an information retrieval system, or translating, in whole or in part, without the prior written consent of National Instruments Corporation.

Trademarks

LabVIEW[®], NI-DAQ[®], and RTSI[®], are trademarks of National Instruments Corporation.

Product and company names listed are trademarks or trade names of their respective companies.

Warning Regarding Medical and Clinical Use of National Instruments Products

National Instruments products are not designed with components and testing intended to ensure a level of reliability suitable for use in treatment and diagnosis of humans. Applications of National Instruments products involving medical or clinical treatment can create a potential for accidental injury caused by product failure, or by errors on the part of the user or application designer. Any use or application of National Instruments products for or involving medical or clinical treatment must be performed by properly trained and qualified medical personnel, and all traditional medical safeguards, equipment, and procedures that are appropriate in the particular situation to prevent serious injury or death should always continue to be used when National Instruments products are being used. National Instruments products are NOT intended to be a substitute for any form of established process, procedure, or equipment used to monitor or safeguard human health and safety in medical or clinical treatment.

Contents

About This Manual	xi
Organization of This Manual	xi
Conventions Used in This Manual	xii
Related Documentation	xiii
Customer Communication	xiii
Chapter 1	
Introduction	1-1
What Your Kit Should Contain	1-2
Optional Software	1-2
Optional Equipment	1-3
Custom Cables	1-3
Unpacking	1-4
Chapter 2	
Configuration and Installation	2-1
Module Configuration	2-1
Jumper Configuration	2-5
Jumper W1	2-5
Jumper W5	2-5
Using Jumpers W1 and W5	2-5
Using Jumpers W2, W3, and W4	2-7
Hardware Installation	2-7
Signal Connections	2-8
Front Connector	2-9
Front Connector Signal Descriptions	2-10
Contact Protection for Inductive Load Connections	2-10
Terminal Block	2-12
SCXI-1324 Terminal Block	2-12
Signal Connection.	2-13
SCXI-1324 Installation.	2-15
Rear Signal Connector	2-15
Rear Signal Connector Signal Descriptions	2-17
Digital I/O Signal Connections	2-17
Timing Requirements and Communication Protocol.....	2-19
Communication Signals	2-19
Chapter 3	
Theory of Operation	3-1
Functional Overview	3-1
SCXIbus Connector	3-2
SCXIbus Connector Signal Descriptions	3-4
Digital Interface	3-5
Digital Control Circuitry	3-6
Relay Channels	3-7

Chapter 4	
Register Descriptions	4-1
Register Description	4-1
Register Description Format	4-1
SCXI-1160 Registers	4-1
Address Handler	4-1
Module ID Register	4-3
Data Register	4-4
Status Register	4-5
Parking Register	4-6
Slot 0 Register Descriptions	4-7
Slot-Select Register	4-8

Chapter 5	
Programming	5-1
Programming Considerations	5-1
Notation	5-1
Register Writes	5-1
Register Selection and Write Procedure	5-2
Initialization	5-3
Examples	5-3
Example 1	5-4
Example 2	5-4
Example 3	5-5

Appendix A	
Specifications	A-1
Contact Ratings	A-1
Physical	A-2
Operating Environment	A-2
Storage Environment	A-2

Appendix B	
Rear Signal Connector	B-1
Rear Signal Connector Signal Descriptions	B-2

Appendix C	
SCXIbus Connector	C-1
SCXIbus Connector Signal Descriptions	C-3

Appendix D	
SCXI-1120 Front Connector	D-1
Front Connector Signal Descriptions	D-2

Appendix E	
SCXI-1160 Cabling	E-1
SCXI-1340 Cable Assembly	E-1
SCXI-1340 Installation	E-2
SCXI-1341 Lab-NB, Lab-PC, or Lab-PC+ and SCXI-1344 Lab-LC Cable Assembly	E-3

SCXI-1341 and SCXI-1344 Installation	E-4
SCXI-1342 PC-LPM-16 Adapter Board	E-5
SCXI-1342 Installation	E-6
DIO-96 Board Connection AT-MIO-16D, and AT-MIO-64F-5 Board Connection.....	E-6
SCXI-1351 and NB5 Cable Installation.....	E-7
SCXI-1348 DIO-32F Adapter Board	E-8
SCXI-1348 Installation	E-10
SCXI-1180 Feedthrough Panel	E-10
SCXI-1180 Installation	E-10
SCXI-1302 50-Pin Terminal Block	E-12
SCXI-1302 Wiring Procedure.....	E-12
SCXI-1302 Installation	E-13
SCXI-1351 One-Slot Cable Extender	E-13
SCXI-1351 Installation	E-14
Multiple-Chassis Connections for the SCXI-1160	E-14
SCXI-1350 Multichassis Adapter	E-14
SCXI-1350 Installation	E-14
SCXI-1343 Rear Screw Terminal Adapter	E-15
SCXI-1343 Installation	E-16

Appendix F

Aromat Relay Technical Data	F-1
--	------------

Appendix G

Customer Communication.....	G-1
------------------------------------	------------

Glossary	Glossary-1
-----------------------	-------------------

Index	Index-1
--------------------	----------------

Figures

Figure 1-1.	SCXI-1160 Relay Module	1-1
Figure 2-1.	SCXI-1160 General Parts Locator Diagram	2-2
Figure 2-2.	Detailed Parts Locator Diagram	2-3
Figure 2-3.	SCXI-1160 Front Connector Pin Assignment	2-9
Figure 2-4.	Contact Protection Using a Flyback Diode for DC Inductive Loads	2-11
Figure 2-5.	Arc Suppressor Pad Locations	2-12
Figure 2-6.	SCXI-1324 Parts Locator Diagram	2-14
Figure 2-7.	SCXI-1160 Rear Signal Connector Pin Assignment	2-16
Figure 2-8.	Slot-Select Timing Diagram	2-20
Figure 2-9.	Serial Data Timing Diagram	2-21
Figure 2-10.	Address Handler Timing Diagram	2-22
Figure 2-11.	Data Register Write Timing Diagram	2-23
Figure 2-12.	SCXI-1160 Module ID Register Timing Diagram	2-24
Figure 2-13.	SCXI-1160 Status Register Timing Diagram	2-25
Figure 3-1.	SCXI-1160 Block Diagram	3-1
Figure 3-2.	SCXIbus Connector Pin Assignment	3-3
Figure 3-3.	Digital Interface Circuitry Block Diagram	3-5
Figure 3-4.	SCXI-1160 Digital Control	3-6
Figure B-1.	SCXI-1160 Rear Signal Connector Pin Assignment	B-1
Figure C-1.	SCXIbus Connector Pin Assignment	C-2
Figure D-1.	SCXI-1160 Front Connector Pin Assignment	D-1
Figure E-1.	SCXI-1340 Installation	E-3
Figure E-2.	SCXI-1351 and NB5 Cable Installation	E-8
Figure E-3.	SCXI-1180 Rear Connections	E-11
Figure E-4.	SCXI-1180 Front Panel Installation	E-12
Figure E-5.	SCXI-1350 Cover Removal	E-13

Tables

Table 2-1.	Digital Signal Connections and Jumper Settings	2-6
Table 2-2.	COM to NO Arc Suppressor Placement	2-11
Table 2-3.	COM to NC Arc Suppressor Placement	2-12
Table 2-4.	SCXIbus to SCXI-1160 Rear Signal Connector to Data Acquisition Board Pin Equivalences	2-19
Table 3-1.	SCXIbus Equivalentents for the Rear Signal Connector	3-5
Table 4-1.	Register Addresses	4-2
Table 4-2.	Truth Table for Resetting and Setting Relays	4-4
Table 5-1.	SCXIbus to SCXI-1160 Rear Signal Connector to Data Acquisition Board Pin Equivalences	5-2

Table E-1.	SCXI-1160 and Board Pinout Equivalences	E-2
Table E-2.	SCXI-1341 and 1344 Pin Translations	E-4
Table E-3.	SCXI-1342 Pin Translations	E-5
Table E-4.	SCXI-1160 and DIO-96 Board Pinout Equivalences	E-7
Table E-5.	SCXI-1348 Pin Translations	E-9
Table E-6.	SCXI-1343 Pin Connections	E-15

About This Manual

This manual describes the electrical and mechanical aspects of the SCXI-1160 and contains information concerning its operation and programming. The SCXI-1160 is a member of the National Instruments Signal Conditioning eXtensions for Instrumentation (SCXI) Series modules for the National Instruments data acquisition plug-in boards. This module is designed for switching and controlling low-level and power signals. The SCXI-1160 operates as 16 relay channels. Each channel is isolated and independently configurable.

This manual describes the installation, basic programming considerations, and theory of operation for the SCXI-1160.

Organization of This Manual

The *SCXI-1160 User Manual* is organized as follows:

- Chapter 1, *Introduction*, describes the SCXI-1160; lists the contents of your SCXI-1160 kit; describes the optional software, optional equipment, and custom cables; and explains how to unpack the SCXI-1160 kit.
- Chapter 2, *Configuration and Installation*, describes the SCXI-1160 jumper configurations, installation of the SCXI-1160 into the SCXI chassis, signal connections to the SCXI-1160, and cable wiring.
- Chapter 3, *Theory of Operation*, contains a functional overview of the SCXI-1160 module and explains the operation of each functional unit making up the SCXI-1160.
- Chapter 4, *Register Descriptions*, describes in detail the SCXI-1160 Address Handler, the Module ID Register, the Data Register, the Status Register, and the Slot 0 registers.
- Chapter 5, *Programming*, contains a functional programming description of the SCXI-1160 and Slot 0.
- Appendix A, *Specifications*, lists the specifications for the SCXI-1160.
- Appendix B, *Rear Signal Connector*, describes the pinout and signal names for the SCXI-1160 50-pin rear signal connector, including a description of each connection.
- Appendix C, *SCXIBus Connector*, describes the pinout and signal names for the SCXI-1160 96-pin SCXIBus connector, including a description of each connection.
- Appendix D, *SCXI-1160 Front Connector*, describes the pinout and signal names for the SCXI-1160 front connector, including a description of each connection.
- Appendix E, *SCXI-1160 Cabling*, describes how to use and install the hardware accessories for the SCXI-1160.
- Appendix F, *Aromat Relay Technical Data*, contains technical data on Aromat Corporation relays.

- Appendix G, *Customer Communication*, contains forms you can use to request help from National Instruments or to comment on our products.
- The *Glossary* contains an alphabetical list and description of terms used in this manual, including abbreviations, acronyms, metric prefixes, mnemonics, and symbols.
- The *Index* contains an alphabetical list of key terms and topics in this manual, including the page where you can find each one.

Conventions Used in This Manual

The following conventions are used in this manual:

DIO board	DIO board refers to the National Instruments AT-DIO-32F, MC-DIO-24, MC-DIO-32F, NB-DIO-24, NB-DIO-96, NB-DIO-32F, PC-DIO 24, and PC-DIO-96 digital I/O data acquisition boards unless otherwise noted.
<i>italic</i>	Italic text denotes emphasis, a cross reference, or an introduction to a key concept.
Lab board	Lab board refers to the National Instruments Lab-LC, Lab-NB, Lab-PC, and Lab-PC+ boards unless otherwise noted.
MC	MC refers to the Micro Channel series computers.
MIO board	MIO board refers to the National Instruments AT-MIO-16, AT-MIO-16F-5, AT-MIO-16X, MC-MIO-16, NB-MIO-16, and NB-MIO-16X multichannel I/O data acquisition boards unless otherwise noted.
monospace	Lowercase text in this font denotes text or characters that are to be literally input from the keyboard, sections of code, programming examples, and syntax examples. This font is also used for the proper names of disk drives, paths, directories, programs, subprograms, subroutines, device names, functions, variables, filenames, and extensions, and for statements and comments taken from program code.
NB	NB refers to the NuBus series computers.
PC	PC refers to the IBM PC/XT, the IBM PC AT, and compatible computers.
SCXIBus	SCXIBus refers to the backplane in the chassis. A signal on the backplane is referred to as the SCXIBus <signal name> line (or signal). The SCXIBus descriptor may be omitted when the meaning is clear. Descriptions of all SCXIBus signals are given in Appendix C, <i>SCXIBus Connector</i> .
Slot 0	Slot 0 refers to the power supply and control circuitry in the SCXI chassis.

Abbreviations, acronyms, metric prefixes, mnemonics, symbols, and terms are listed in the *Glossary*.

Related Documentation

The following documents contain information that you may find helpful as you read this manual:

- *AT-DIO-32F User Manual* (320147-01)
- *AT-MIO-16 User Manual* (part number 320476-01)
- *AT-MIO-16F-5 User Manual* (part number 320266-01)
- *AT-MIO-16X User Manual* (part number 320488-01)
- *Lab-LC User Manual* (part number 320380-01)
- *Lab-NB User Manual* (part number 320174-01)
- *Lab-PC User Manual* (part number 320205-01)
- *Lab-PC+ User Manual* (part number 320502-01)
- *MC-DIO-24 User Manual* (part number 320129-01)
- *MC-DIO-32F User Manual* (part number 320128-01)
- *MC-MIO-16 User Manual*, Revisions A to C (part number 320130-01)
- *MC-MIO-16 User Manual*, Revision D (part number 320560-01)
- *NB-DIO-24 User Manual* (part number 320094-01)
- *NB-DIO-32F User Manual* (part number 320095-01)
- *NB-DIO-96 User Manual* (part number 320384-01)
- *NB-MIO-16 User Manual* (part number 320295-01)
- *NB-MIO-16X User Manual* (part number 320157-01)
- *PC-DIO-24 User Manual* (320288-01)
- *PC-DIO-96 User Manual* (320289-01)
- *PC-LPM-16 User Manual* (part number 320287-01)
- *SCXI-1000/1001 User Manual* (part number 320423-01)

Customer Communication

National Instruments wants to receive your comments on our products and manuals. We are interested in the applications you develop with our products, and we want to help if you have problems with them. To make it easy for you to contact us, this manual contains comment and configuration forms for you to complete. These forms are in Appendix G, *Customer Communication*, at the end of this manual.

Chapter 1

Introduction

This chapter describes the SCXI-1160; lists the contents of your SCXI-1160 kit; describes the optional software, optional equipment, and custom cables; and explains how to unpack the SCXI-1160 kit.

Figure 1-1 shows the SCXI-1160 module.

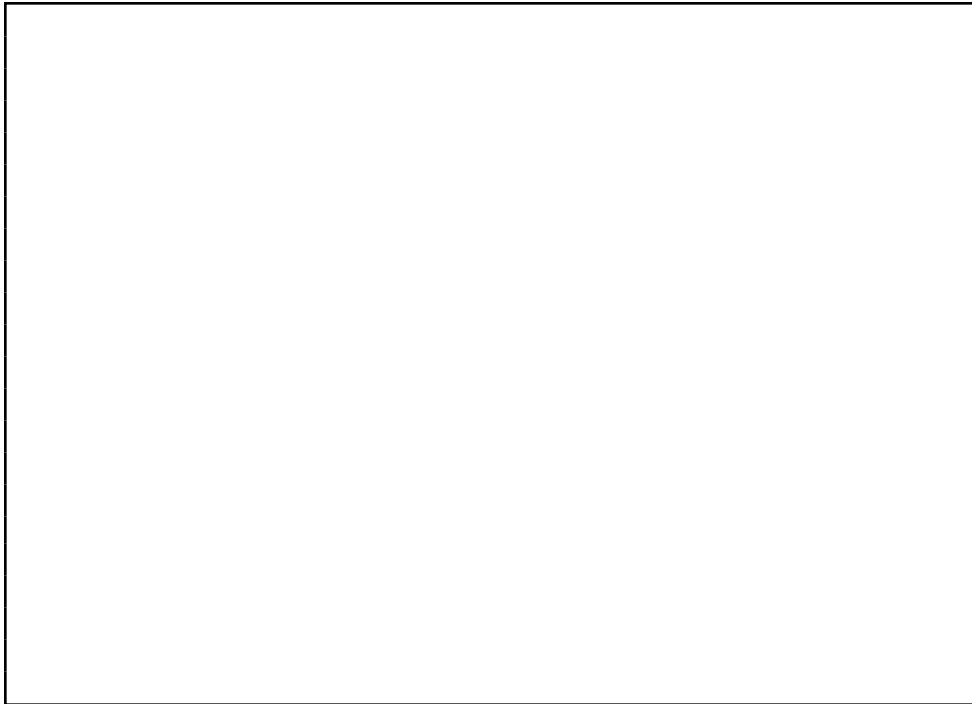

Figure 1-1. SCXI-1160 Relay Module

The SCXI-1160 module consists of 16 isolated single-pole double-throw (SPDT) or form C latching relay channels. The SCXI-1160 is a module for switching and controlling.

The SCXI-1160 operates with full functionality with National Instruments MIO-16 boards; Lab-NB, Lab-PC, Lab-PC+, Lab-LC, and PC-LPM-16 boards; and with the DIO-24, DIO-32F, and DIO-96 boards. You can also use the SCXI-1160 with other systems that comply with the specifications given in Chapter 2, *Configuration and Installation*. You can control several SCXI-1160s in a single chassis with one data acquisition board.

An additional shielded terminal block has screw terminals for easy signal attachment to the SCXI-1160.

With the SCXI-1160, the SCXI chassis can serve as a controller or switcher in laboratory testing, production testing, and industrial process monitoring.

What Your Kit Should Contain

The contents of the SCXI-1160 kit (part number 776572-60) are listed as follows.

Kit Component	Part Number
SCXI-1160 module	182139-01
<i>SCXI-1160 User Manual</i>	320513-01

If your kit is missing any of the components, contact National Instruments.

Optional Software

This manual contains complete instructions for directly programming the SCXI-1160. You can order separate software packages for controlling the SCXI-1160 from National Instruments.

When you combine the PC, AT, and MC data acquisition boards with the SCXI-1160, you can use LabVIEW for Windows or LabWindows for DOS. LabVIEW and LabWindows are innovative program development software packages for data acquisition and control applications. LabVIEW uses graphical programming, whereas LabWindows enhances Microsoft C and QuickBASIC. Both packages include extensive libraries for data acquisition, instrument control, data analysis, and graphical data presentation.

Your National Instruments data acquisition board is shipped with the NI-DAQ software. NI-DAQ has a library of functions that can be called from your application programming environment. These functions include routines for analog input (A/D conversion), buffered data acquisition (high speed A/D conversion), analog output (D/A conversion), waveform generation, digital I/O, counter/timer, SCXI, RTSI, and self-calibration. NI-DAQ maintains a consistent software interface among its different versions so you can switch between platforms with minimal modifications to your code.

You can also use the SCXI-1160, together with the PC, AT, and MC data acquisition boards, with NI-DAQ software for DOS/Windows/LabWindows. NI-DAQ software for DOS/Windows/LabWindows comes with language interfaces for Professional BASIC, Turbo Pascal, Turbo C, Turbo C++, Borland C++, and Microsoft C for DOS; and Visual Basic, Turbo Pascal, Microsoft C with SDK, and Borland C++ for Windows. NI-DAQ software for DOS/Windows/LabWindows is on high-density 5.25 in. and 3.5 in. diskettes.

You can use the SCXI-1160, together with the NB Series data acquisition boards, with LabVIEW for Macintosh, a software system that features interactive graphics, a state-of-the-art user interface, and a powerful graphical programming language. The LabVIEW Data Acquisition VI Library, a series of VIs for using LabVIEW with National Instruments boards, is included with LabVIEW. The LabVIEW Data Acquisition VI Library is functionally equivalent to the NI-DAQ software for Macintosh.

You can also use the SCXI-1160, combined with the NB Series data acquisition boards, with NI-DAQ software for Macintosh. NI-DAQ software for Macintosh, which is shipped with all National Instruments Macintosh data acquisition boards, comes with language interfaces for

MPW C, THINK C, Pascal, and Microsoft QuickBASIC. Any language that uses Device Manager Toolbox calls can access NI-DAQ software for Macintosh.

Part numbers for these software products are as follows:

Software	Part Number
LabVIEW for Windows	776670-01
LabWindows	
Standard package	776473-01
Advanced Analysis Library	776474-01
Standard package with Advanced Analysis Library	776475-01
NI-DAQ software for DOS/Windows/LabWindows	776250-01
LabVIEW for Macintosh	776141-01
NI-DAQ software for Macintosh	776181-01

Optional Equipment

Equipment	Part Number
SCXI-1324 front terminal block	776573-24
SCXI-1340 cable assembly	776574-40
SCXI-1341 Lab-NB/Lab-PC/Lab-PC+ cable assembly	776574-41
SCXI-1342 PC-LPM-16 cable assembly	776574-42
SCXI-1343 rear screw terminal adapter	776574-43
SCXI-1344 Lab-LC cable assembly	776574-44
SCXI-1351 one slot extender cable	776575-51
SCXI-1348 DIO-32F cable assembly	776574-48
Standard ribbon cable 0.5 m	180524-05
1.0 m	180524-10
NB5 cable 0.5 m	181304-05
1.0 m	181304-10

Refer to the *Signal Connections* section in Chapter 2, *Configuration and Installation*, and to Appendix E, *SCXI-1160 Cabling*, for additional information on cabling, connectors, and adapters.

Custom Cables

The SCXI-1160 rear signal connector is a 50-pin male ribbon-cable header. The manufacturer part number National Instruments uses for this header is as follows:

- AMP Inc. (part number 1-103310-0)

The mating connector for the SCXI-1160 rear signal connector is a 50-position polarized ribbon-socket connector with strain relief. National Instruments uses a polarized or keyed connector to prevent inadvertent upside-down connection to the SCXI-1160. Recommended manufacturer part numbers for this mating connector are as follows:

- Electronic Products Division/3M (part number 3425-7650)
- T&B/Ansley Corporation (part number 609-5041CE)

Standard 50-conductor 28 AWG stranded ribbon cables that work with these connectors are as follows:

- Electronic Products Division/3M (part number 3365/50)
- T&B/Ansley Corporation (part number 171-50)

The SCXI-1160 front connector is a special 48-pin DIN C male connector. The manufacturer part number National Instruments uses for this connector is as follows:

- ERNI Components, Inc. (part number 913523)

The mating connector for the SCXI-1160 front connector is a special 48-pin reversed DIN C female connector. National Instruments uses a polarized and keyed connector to prevent inadvertent upside-down connection to the SCXI-1160. The manufacturer part number National Instruments uses for this mating connector is as follows:

- ERNI Components, Inc. (part number 913524)

These connectors were selected to meet UL 1244 for 1,500 Vrms isolation.

Unpacking

Your SCXI-1160 module is shipped in an antistatic package to prevent electrostatic damage to the module. Several components on the module can be damaged by electrostatic discharge. To avoid such damage in handling the module, take the following precautions:

- Touch the antistatic package to a metal part of your SCXI chassis before removing the module from the package.
- Remove the module from the package and inspect the module for loose components or any other sign of damage. Notify National Instruments if the module appears damaged in any way. *Do not* install a damaged module into your SCXI chassis.

Chapter 2

Configuration and Installation

This chapter describes the SCXI-1160 jumper configurations, installation of the SCXI-1160 into the SCXI chassis, signal connections to the SCXI-1160, and cable wiring.

Module Configuration

The SCXI-1160 includes five jumpers that are shown in the parts locator diagrams in Figures 2-1 and 2-2. Figure 2-1 shows the general parts locator diagram of the SCXI-1160 and Figure 2-2 shows a detailed parts locator diagram of the SCXI-1160.



Figure 2-1. SCXI-1160 General Parts Locator Diagram

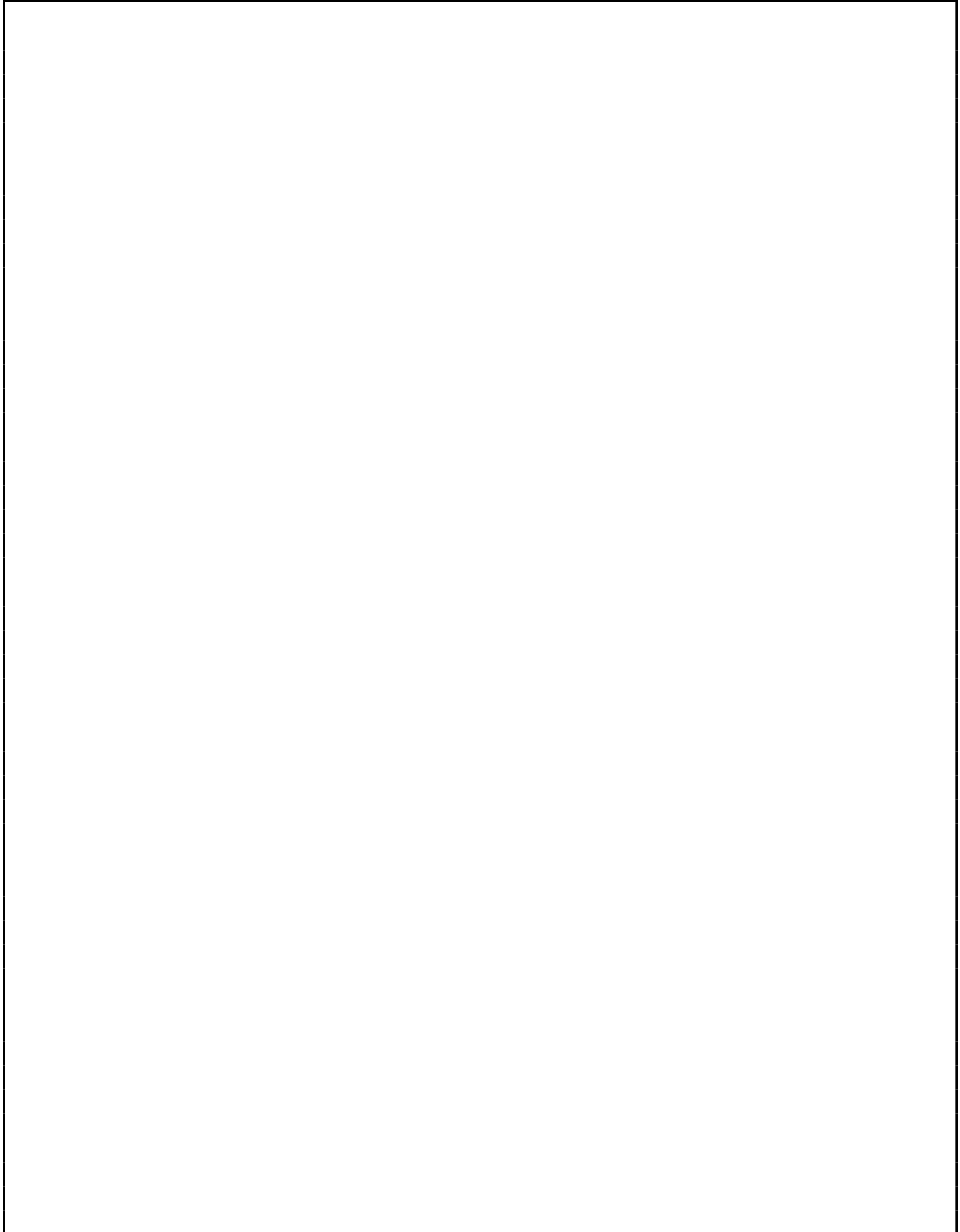

Figure 2-2. Detailed Parts Locator Diagram

The following warnings contain important safety information concerning hazardous voltages.

Warnings: *Do not operate the module in an explosive atmosphere or where there may be flammable gases or fumes.*

Keep away from live circuits. Do not remove equipment covers or shields unless you are trained to do so. If signal wires are connected to the module or terminal block, dangerous voltages may exist even when the equipment is turned off. To avoid dangerous electrical shock, do not perform procedures involving cover or shield removal unless you are qualified to do so.

Do not operate damaged equipment. The safety protection features built into this module can become impaired if the module becomes damaged in any way. If it is damaged, turn the module off and do not use it until service-trained personnel can check its safety. If necessary, return the module to National Instruments for service and repair to ensure that its safety is not compromised.

Do not substitute parts or modify equipment. Because of the danger of introducing additional hazards, do not install unauthorized parts or modify the module. Return the module to National Instruments for service and repair to ensure that its safety features are not compromised.

When using the terminal block with high common-mode voltages, your signal wires *must* be insulated appropriately. National Instruments is *not* liable for any damages or injuries resulting from inadequate signal wire insulation.

When connecting or disconnecting signal lines to the SCXI-1324 terminal block screw terminals, the lines must be powered off. Potential differences between the lines and the SCXI-1160 ground create a shock hazard while connecting the lines.

Connections, including power signals to ground and vice versa, that exceed any of the maximum signal ratings on the SCXI-1160 can result in damage to any or all of the boards connected to the SCXI chassis, to the host computer, and to the SCXI-1160 module. National Instruments *is not liable for any damages or injuries* resulting from incorrect signal connections.

If high voltages (≥ 42 Vrms) are present, the *safety earth ground must be connected to the strain-relief tab*. This maintains compliance with UL 1244 and provides protection against electric shock when the terminal block is not connected to the chassis. To connect the safety earth ground to the strain-relief tab, run an earth ground wire in the cable from the signal source to the terminal block. National Instruments is *not* liable for any damages or injuries resulting from inadequate safety earth ground connections.

The jumpers are used as follows:

- Jumper W1 connects a pullup resistor to the SERDATOUT signal on the rear signal connector.
- Jumpers W2, W3, and W4 select whether the SCXI-1160 is to be connected to a DIO board or to an MIO board. If nothing is cabled to the rear signal connector of the SCXI-1160, the position of these jumpers is irrelevant.
- Jumper W5 carries the SCXIBus MISO line, after buffering, to the SERDATOUT signal on the rear signal connector.

Further configuration of the board is software controlled and will be discussed later in this chapter.

Jumper Configuration

All five jumpers on the SCXI-1160 are for digital communication between the data acquisition board and the SCXI-1160 module. Only one module per chassis is connected to the data acquisition board, which allows communication with all other modules. On the other modules, the jumper settings are irrelevant.

The SCXI-1160 has two jumpers, W1 and W5, dedicated for communication between the SCXI-1160 and the data acquisition board. Jumpers W2, W3, and W4 indicate to the module what type of data acquisition board is to be connected to its rear signal connector.

Jumper W1

Position 1 connects a 2.2 k Ω pullup resistor to the SERDATOUT line. This is the factory-default setting. Position 3 does not connect the pullup resistor to the SERDATOUT line.

Jumper W5

Position 1 connects the SCXIBus MISO line, after buffering, to the SERDATOUT pin of the rear signal connector. This is the factory-default setting. In this setting, along with the proper setting of jumper W1, the data acquisition board can read the Module ID Register or the Status Register of the SCXI-1160. See the *Timing Requirements and Communication Protocol* section later in this chapter, and Chapter 4, *Register Descriptions*, for information on reading the Module ID Register and the Status Register. See Appendix E, *SCXI-1160 Cabling*, for the pin equivalences of the SCXI-1160 rear signal connector and the data acquisition board I/O connector.

Position 3 disconnects SERDATOUT from the SCXIBus MISO line.





Using Jumpers W1 and W5

If a module is not connected to a data acquisition board, the positions of jumpers W1 and W5 are irrelevant. Jumpers W1 and W5 give the data acquisition board access to the MISO line on the backplane. You can use the MISO line to read the Module ID Register of modules. National Instruments software does not use this ability. You must indicate to the software which module

is in which slot. In addition to reading the Module ID Register, the MISO line on the SCXI-1160 can read the Status Register, which indicates the status of the relays. National Instruments software uses this feature.

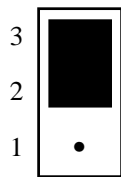
The SERDATOUT line is driven with an open-collector driver, which is a driver that actively drives low or goes to a high-impedance state, relying on a pullup resistor to make the signal line go high. When using a single chassis, set both jumpers W1 and W5 in position 1 on the SCXI-1160 that is connected to the data acquisition board. In this setting, the module drives MISO to SERDATOUT and connects the necessary pullup resistor to the SERDATOUT line. When using multiple chassis, set jumper W5 in position 1 on all of the SCXI-1160s that are cabled to the data acquisition board. Set jumper W1 in position 1 on only one of the SCXI-1160s that are cabled to the data acquisition board. It does not matter which of the SCXI-1160s that are cabled to the data acquisition board has the pullup connected. Set jumper W1 in position 3 on all of the other SCXI-1160 modules that are cabled to the data acquisition board. If too many pullup resistors are attached to the SERDATOUT line, the drivers cannot drive the line low. See Table 2-1 for the description and configuration of the jumper settings.

Table 2-1. Digital Signal Connections and Jumper Settings

Jumper	Description	Configuration
W1	Parking position	
W1	Factory Setting—Connects pullup to SERDATOUT	
W5	Parking position	
W5	Factory setting—Connects MISO to SERDATOUT	

(continues)

Table 2-1. Digital Signal Connections and Jumper Settings (Continued)

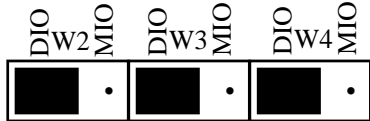
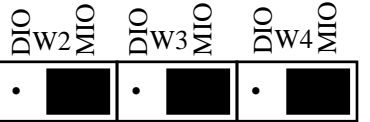
Jumper	Description	Configuration
W2, W3, W4	Data acquisition board is a DIO type board.	
W2, W3, W4	Data acquisition board is an MIO type board.	

Using Jumpers W2, W3, and W4

You can use two types of data acquisition boards to communicate with the SCXI-1160. The multifunction I/O (MIO) type boards are National Instruments boards that have both analog and digital inputs and outputs. Boards include MIO-16, MIO-16X, MIO-16F-5, Lab Series (Lab-NB, Lab-PC, Lab-PC+, and Lab-LC), and PC-LPM-16 boards. The DIO type boards are National Instruments boards that have only digital inputs and outputs. These boards include the DIO-24, DIO-32F, and DIO-96.

All three jumpers have labels indicating the DIO and the MIO configurations. If you want to use the SCXI-1160 with a DIO type board, place all three jumpers in the DIO position. This position is the factory setting. If you want to use the SCXI-1160 with an MIO type board, place all three jumpers in the MIO position. If nothing is cabled to the rear signal connector of the SCXI-1160, the position of these jumpers is irrelevant.

Hardware Installation

You can install the SCXI-1160 in any available SCXI chassis. After you have made any necessary changes and have verified and recorded the jumper settings on the form in Appendix G, *Customer Communication*, you are ready to install the SCXI-1160. The following are general installation instructions; consult the user manual or technical reference manual of your SCXI chassis for specific instructions and warnings.

1. Turn off the computer that contains the data acquisition board or disconnect it from your SCXI chassis.
2. Turn off the SCXI chassis. Do not insert the SCXI-1160 into a chassis that is turned on.
3. Insert the SCXI-1160 into the board guides. Gently guide the module into the back of the slot until the connectors make good contact. If a cable assembly has already been installed in the rear of the chassis, the module and cable assembly must be firmly engaged; however, do not *force* the module into place.
4. Screw the front mounting panel of the SCXI-1160 to the top and bottom threaded strips of your SCXI chassis.

5. If this module is to be connected to an MIO-16 or a DIO-24 data acquisition board, attach the connector at the metal end of the SCXI-1340 cable assembly to the rear signal connector on the SCXI-1160 module. Screw the rear panel to the rear threaded strip. Attach the loose end of the cable to the data acquisition board.

Note: For installation procedures with other SCXI accessories and data acquisition boards, consult Appendix E, *SCXI-1160 Cabling*.

6. Check the installation.
7. Turn on the SCXI chassis.
8. Turn on the computer or reconnect it to your chassis.

The SCXI-1160 board is installed and ready for operation.

Signal Connections

This section describes the signal connections to the SCXI-1160 board via the SCXI-1160 front connector and rear signal connector, and includes specifications and connection instructions for the SCXI-1160 connector signals.

Note: In high-current applications, the thin layer of gold plating on the relay contact may be destroyed. Although this will not affect the high current application, you may experience a high contact resistance in a low-current application and be unable to use the relay.

Warning: Connections to and between any terminals of the SCXI-1160 that exceed any of the maximum ratings of input signals on the SCXI-1160 can result in damage to the SCXI-1160 module and to the SCXIbus. Maximum input ratings for each signal are given in this chapter under the discussion of that signal. National Instruments is *not* liable for any damages resulting from such signal connections.



Front Connector

Figure 2-3 shows the pin assignments for the SCXI-1160 front connector.

Pin Number	Signal Name	Column			Signal Name
		A	B	C	
32	COM (0)	○			
31	NO (0)	○		○	NC (0)
30	COM (1)	○			
29	NO (1)	○		○	NC (1)
28	COM (2)	○			
27	NO (2)	○		○	NC (2)
26	COM (3)	○			
25	NO (3)	○		○	NC (3)
24	COM (4)	○			
23	NO (4)	○		○	NC (4)
22	COM (5)	○			
21	NO (5)	○		○	NC (5)
20	COM (6)	○			
19	NO (6)	○		○	NC (6)
18	COM (7)	○			
17	NO (7)	○		○	NC (7)
16	COM (8)	○			
15	NO (8)	○		○	NC (8)
14	COM (9)	○			
13	NO (9)	○		○	NC (9)
12	COM (10)	○			
11	NO (10)	○		○	NC (10)
10	COM (11)	○			
9	NO (11)	○		○	NC (11)
8	COM (12)	○			
7	NO (12)	○		○	NC (12)
6	COM (13)	○			
5	NO (13)	○		○	NC (13)
4	COM (14)	○			
3	NO (14)	○		○	NC (14)
2	COM (15)	○			
1	NO (15)	○		○	NC (15)

Figure 2-3. SCXI-1160 Front Connector Pin Assignment

Front Connector Signal Descriptions

Pin	Signal Name	Description
A1, A3, A5, A7, A9, A11, A13, A15, A17, A19, A21, A23, A25, A27, A29, A31	NO <15..0>	Normally Open Contact – These are the normally open contacts of the relays 15 through 0.
B2, B4, B6, B8, B10, B12, B14, B16, B18, B20, B22, B24, B26, B28, B30, B32	COM <15..0>	Common Contact – These are the common contacts of the relays 15 through 0.
C1, C3, C5, C7, C9, C11, C13, C15, C17, C19, C21, C23, C25, C27, C29, C31	NC <15..0>	Normally Closed Contact – These are the normally closed contacts of the relays 15 through 0.

All contacts have a working common mode voltage of 250 VAC or VDC. The contact-to-contact breakdown voltage is 750 Vrms. The contact-to-coil breakdown voltage is 1,500 Vrms. Please refer to the module specifications listed in Appendix A for further details before connecting the signals to the relay contacts.

Contact Protection for Inductive Load Connections

When inductive loads are connected to the relays, a large counter electromotive force may occur at relay switching time due to the energy stored in the inductive load. These flyback voltages can severely damage the relay contacts and greatly shorten the life of the relay.

It is best to limit these flyback voltages at your inductive load by installing a flyback diode for DC loads or an MOV for AC loads. Refer to the section, *3. Contact Protection*, in Appendix F, *Aromat Relay Technical Data*, for further details.

In addition, the module contains pads on which you can place an arc suppressor protection circuit to limit the voltage spike generated during the switching of inductive loads. These pads are located between the COM position and the NO position and between the COM position and the NC position of the relays.

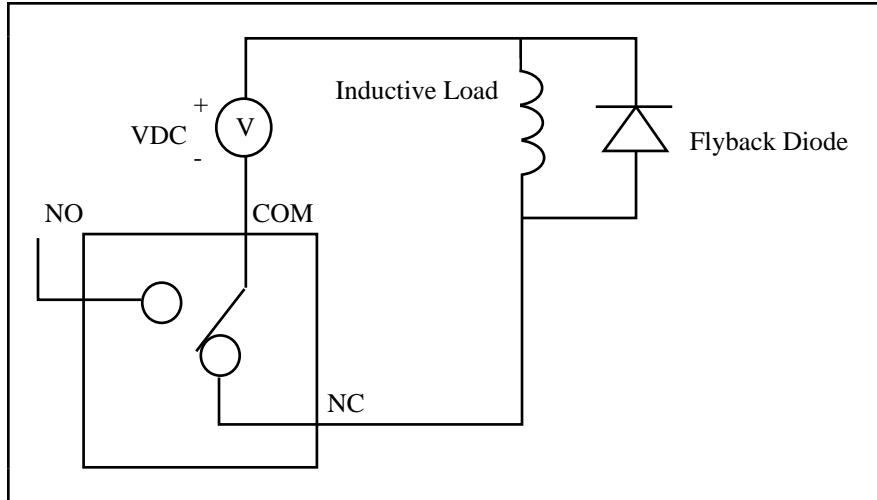

Figure 2-4. Contact Protection Using a Flyback Diode for DC Inductive Loads

To determine where to place each arc suppressor, refer to Table 2-2 and Table 2-3, which indicate the channel and suppressor pad assignments.

Table 2-2. COM to NO Arc Suppressor Placement

COM to NO Channel Number	Transient Voltage Suppressor Reference Designator
0	VR1
1	VR3
2	VR5
3	VR7
4	VR9
5	VR11
6	VR13
7	VR15
8	VR17
9	VR19
10	VR21
11	VR23
12	VR25
13	VR27
14	VR29
15	VR31

Table 2-3. COM to NC Arc Suppressor Placement

COM to NC Channel Number	Transient Voltage Suppressor Reference Designator
0	VR2
1	VR4
2	VR6
3	VR8
4	VR10
5	VR12
6	VR14
7	VR16
8	VR18
9	VR20
10	VR22
11	VR24
12	VR26
13	VR28
14	VR30
15	VR32

Figure 2-5 shows how to connect a transient voltage suppressor for AC and DC inductive loads.

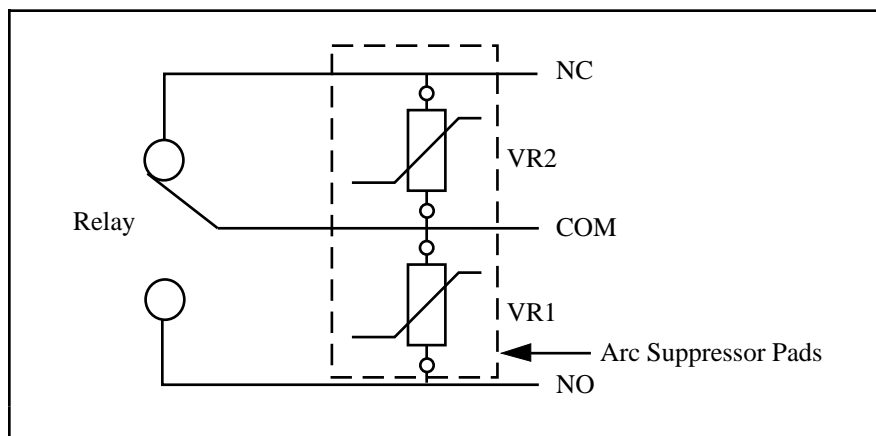

Figure 2-5. Arc Suppressor Pad Locations

Terminal Block

A terminal block with screw terminals is available for easy signal connection to the SCXI-1160 inputs. This kit is listed in the *Optional Equipment* section in Chapter 1, *Introduction*.

SCXI-1324 Terminal Block

The SCXI-1324 terminal block consists of a shielded board with supports to connect it to the SCXI-1160 input connector. There are forty-eight screw terminals for easy signal connection.

When connecting your signals to the SCXI-1324 for use with the SCXI-1160, follow the labeling as indicated in Figure 2-6, *SCXI-1324 Parts Locator Diagram*.

The following warnings contain important safety information concerning hazardous voltages.

- Warnings:**
- When using the terminal block with high voltages, your signal wires *must* be insulated appropriately. National Instruments is *not* liable for any damages or injuries resulting from inadequate signal wire insulation.
 - When connecting or disconnecting signal lines to the SCXI-1324 terminal block screw terminals, the lines must be powered off to avoid a shock hazard.
 - Connections, including power signals to ground and vice versa, that exceed any of the maximum signal ratings on the SCXI-1160 can result in damage to any or all of the boards connected to the SCXI chassis, to the host computer, and to the SCXI-1160 module. National Instruments *is not liable for any damages or injuries* resulting from incorrect signal connections.
 - If high voltages (≥ 42 Vrms) are present, the *safety earth ground must be connected to the strain-relief tab*. This complies with UL 1244 and protects against electric shock when the terminal block is not connected to the chassis. To connect the safety earth ground to the strain-relief tab, run an earth ground wire in the cable from the signal source to the terminal block. National Instruments is *not* liable for any damages or injuries resulting from inadequate safety earth ground connections.

Signal Connection. To connect the signal to the terminal block, use the following procedure:

1. Remove the grounding screw of the top cover.
2. Snap out the top cover of the shield by placing a screwdriver in the groove at the bottom of the terminal block.
3. Slide the signal wires, one at a time, through the front panel strain relief. Additional insulation or padding may be added if necessary.
4. Connect the wires to the screw terminals.
5. Tighten the strain relief by tightening the larger screws.
6. Snap the top cover back in place.
7. Replace the grounding screw to ensure proper shielding.
8. Install contact protection as previously described if your load is inductive.
9. Connect the terminal block to the SCXI-1160 front connector as explained in the *SCXI-1324 Installation* section, the next section in this chapter.

Figure 2-6 shows a parts locator diagram for the SCXI-1324 terminal block.



Figure 2-6. SCXI-1324 Parts Locator Diagram

SCXI-1324 Installation. To connect the terminal block to the SCXI-1160 front connector, follow these steps:

1. Connect the SCXI-1160 front connector to its mating connector on the terminal block.
2. Make sure that the SCXI-1160 top and bottom thumbscrews do not obstruct the rear panel of the terminal block.
3. Tighten the top and bottom screws on the back of the terminal block to hold it securely in place.

Rear Signal Connector

Note: If you will use the SCXI-1160 with a National Instruments data acquisition board and cable assembly, you do not need to read the remainder of this chapter. If you will also use the SCXI-1180 feedthrough panel, the SCXI-1343 rear screw terminal adapter, or the SCXI-1351 one-slot cable extender with the SCXI-1160, read this section.

Figure 2-7 shows the pin assignments for the SCXI-1160 rear signal connector.

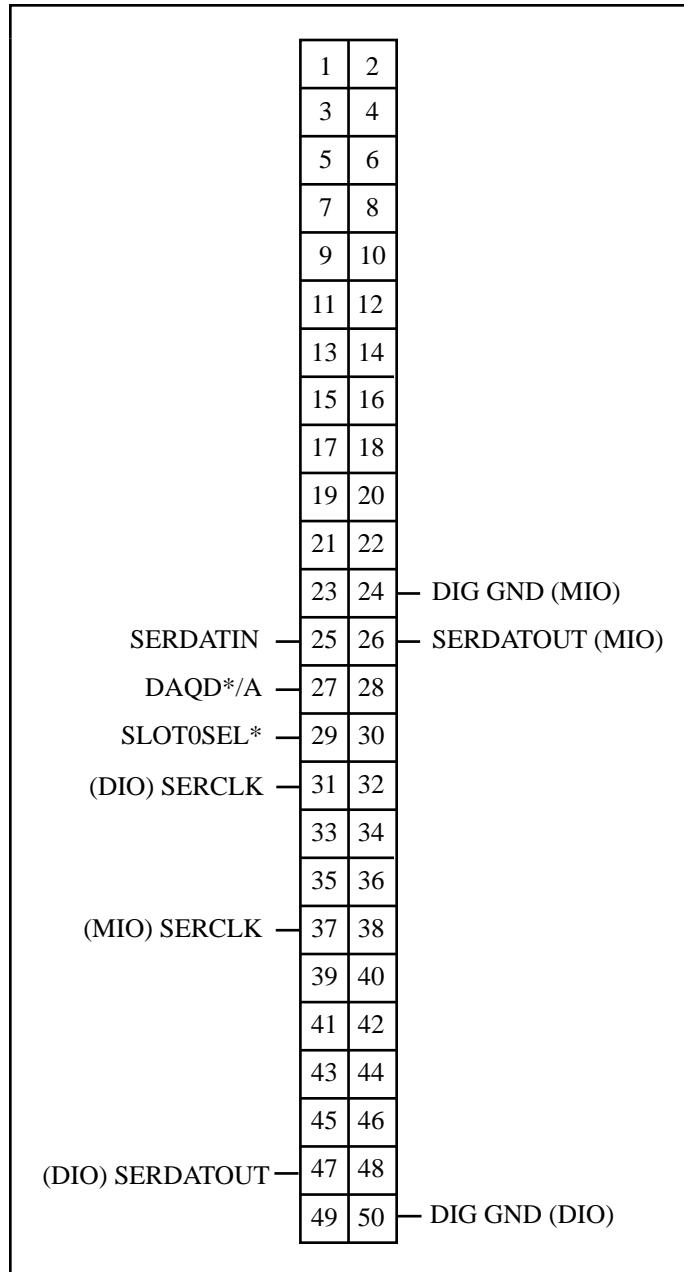

Figure 2-7. SCXI-1160 Rear Signal Connector Pin Assignment

Rear Signal Connector Signal Descriptions

Pin	Signal Name	Description
24 or 50	DIG GND	Digital Ground – Supplies the reference for data acquisition board digital signals and is tied to the module digital ground. Pin 50 is for DIO type boards. Pin 24 is for MIO type boards and jumper W3 selects it.
25	SERDATIN	Serial Data In – Taps into the SCXIBus MOSI line to provide serial input data to a module or Slot 0.
26 or 47	SERDATOUT	Serial Data Out – Taps into the SCXIBus MISO line to accept serial output data from a module. Pin 47 is for DIO type boards. Pin 26 is for MIO type boards and jumper W2 selects it.
27	DAQD*/A	Data Acquisition Board Data/Address Line – Taps into the SCXIBus D*/A line to indicate to the module whether the incoming serial stream is data or address information.
29	SLOT0SEL*	Slot 0 Select – Taps into the SCXIBus INTR* line to indicate whether the information on MOSI is sent to a module or to Slot 0.
31 or 37	SERCLK	Serial Clock – Taps into the SCXIBus SPICLK line to clock the data on the MOSI and MISO lines. Pin 31 is for DIO boards. Pin 37 is for MIO boards and jumper W4 selects it.

All other pins are not connected.

See the *Timing Requirements and Communication Protocol* section later in this chapter for more detailed information on timing.

The signals on the rear signal connector are digital I/O signals. Signal connection guidelines for each of these groups are given in the following section.

Digital I/O Signal Connections

Pins 24 through 27, 29, 31, 37, 47, and 50 constitute the digital I/O lines of the rear signal connector. They are divided into three categories—the digital input signals, the digital output signals, and the digital timing signals.

The digital input signals are pins 24 or 50, 25, 27, 29, and 31 or 37. The data acquisition board uses these pins to configure the SCXI module that the data acquisition board controls.

Each digital line emulates the SCXibus communication signals as follows:

- Pin 25 is SERDATIN and is equivalent to the SCXibus MOSI serial data input line.
- Pin 27 is DAQD*/A and is equivalent to the SCXibus D*/A line. It indicates to the module whether the incoming serial stream on SERDATIN is data (DAQD*/A = 0) or address (DAQD*/A = 1) information.
- Pin 29 is SLOTOSEL* and is equivalent to the SCXibus INTR* line. It indicates whether the data on the SERDATIN line is being sent to Slot 0 (SLOTOSEL* = 0) or to a module (SLOTOSEL* = 1).
- Pin 24 or 50 is the digital ground reference for the data acquisition board digital signals and is tied to the module digital ground via jumper W3. Pins 24 and 50 are *not* tied together.
 - Pin 24 is for MIO type boards with jumpers W2, W3, and W4 in the MIO position.
 - Pin 50 is for DIO type boards with jumpers W2, W3, and W4 in the DIO position.
- Pin 31 or 37 is SERCLK and is equivalent to the SCXibus SPICLK line. These pins clock the serial data on the SERDATIN line into the module registers. Pins 31 and 37 are *not* tied together.
 - Pin 31 is for DIO type boards with jumpers W2, W3, and W4 in the DIO position.
 - Pin 37 is for MIO type boards with jumpers W2, W3, and W4 in the MIO position.

The digital output signal is pin 26 or 47:

- Pin 26 or 47 is SERDATOUT and is equivalent to SCXibus MISO when jumper W5 is in position 1. Pins 26 and 47 are *not* tied together.
 - Pin 26 is for MIO type boards with jumpers W2, W3, and W4 in the MIO position.
 - Pin 47 is for DIO type boards with jumpers W2, W3, and W4 in the DIO position.

When you configure the SCXI-1160 for an MIO type board, the digital I/O signals of the SCXI-1160 match the digital I/O lines of the MIO-16 board. When used with an SCXI-1341, SCXI-1342, or SCXI-1344 cable assembly, the SCXI-1160 signals match the digital lines of the Lab-NB/Lab-PC/Lab-PC+/Lab-LC boards and the PC-LPM-16 board, respectively. When you configure the SCXI-1160 for a DIO type board, the digital I/O signals of the SCXI-1160 match the digital I/O lines of the DIO-24 and DIO-96 boards. When used with an SCXI-1348 cable assembly, the SCXI-1160 signals match the digital lines of the DIO-32F board.

Table 2-4 lists the pin equivalences. For more information, consult Appendix E, *SCXI-1160 Cabling*.

Table 2-4. SCXIbus to SCXI-1160 Rear Signal Connector to Data Acquisition Board Pin Equivalences

SCXIbus Line	SCXI-1160 Rear Signal Connector	MIO-16	Lab-NB/Lab-PC/ Lab-PC+/Lab-LC	PC-LPM-16	DIO-24	DIO-96	DIO-32F
MOSI	SERDATIN	ADIO0	PB4	DOU4	PB3	APB3	DIOB3
D*/A	DAQD*/A	ADIO1	PB5	DOU5	PB2	APB2	DIOB2
INTR*	SLOT0SEL*	ADIO2	PB6	DOU6	PB1	APB1	DIOB1
SPICLK	SERCLK	EXTSTROBE*	PB7	DOU7	PB0	APB0	DIOB0
MISO	SERDATOUT	BDIO0	PC1	DIN6	PA0	APA0	DIOA0

The following specifications and ratings apply to the digital I/O lines.

Absolute maximum voltage
input rating 5.5 V with respect to DIG GND

Digital input specifications (referenced to DIG GND):

V_{IH} input logic high voltage 2 V minimum
 V_{IL} input logic low voltage 0.8 V maximum

I_I input current leakage $\pm 1 \mu\text{A}$ maximum

Digital output specifications (referenced to DIG GND):

V_{OH} output logic high voltage 3.7 V minimum at 4 mA maximum
 V_{OL} output logic low voltage 0.4 V maximum at 4 mA maximum

Timing Requirements and Communication Protocol

Communication Signals

This section describes the methods for communicating on the Serial Peripheral Interface (SPI) bus and their timing requirements. The communication signals are SERDATIN, DAQD*/A, SLOT0SEL*, SERDATOUT, and SERCLK. Furthermore, Slot 0 produces SS* according to data acquisition board programming; therefore SS* timing relationships will also be discussed. For information on the Slot 0 Slot-Select Register, consult Chapter 4, *Register Descriptions*.

Use the following data acquisition board determines to which slot it will talk to by writing a slot-select number to Slot 0. In the case of an SCXI-1001 chassis, this write also determines to which chassis the data acquisition board will talk.

Use the following procedure for selecting a slot in a particular chassis. Figure 2-8 illustrates the timing of this procedure with the example of selecting Slot 11 in Chassis 9. Notice that the factory-default chassis address for the SCXI-1000 is address 0. For information on changing the address of your chassis, consult the *SCXI-1000/1001 User Manual*. An SCXI-1000 chassis will respond to any chassis number.

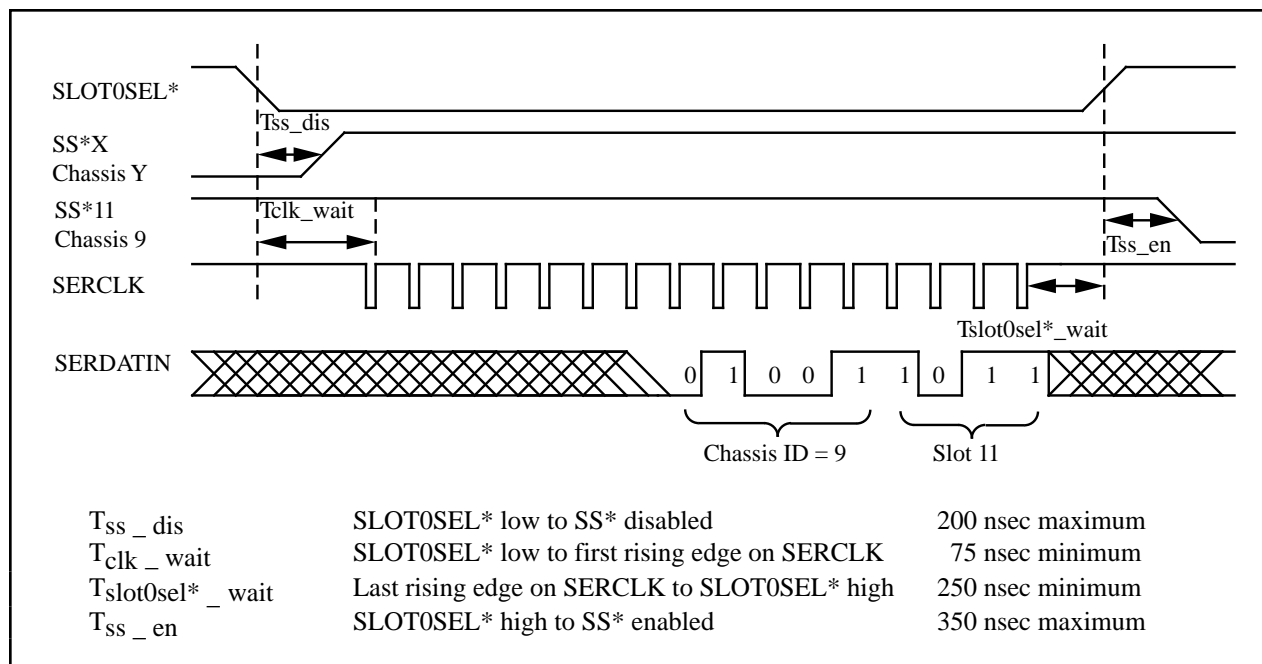

Figure 2-8. Slot-Select Timing Diagram

To write the 16-bit slot-select number to Slot 0, follow these steps:

1. Initial conditions:

SERDATIN = don't care.
 DAQD*/A = 1.
 SLOT0SEL* = 1.
 SERCLK = 1.

2. Clear SLOT0SEL* to 0. This will deassert all SS* lines to all modules in all chassis.

3. For each bit, starting with the MSB, perform the following action:

- a. Set SERDATIN = bit to be sent. These bits are the data that are being written to the Slot-Select Register.
- b. SERCLK = 0.
- c. SERCLK = 1. This rising edge clocks the data.

- Set $SLOT0SEL^*$ to 1. This will assert the SS^* line of the module whose slot number was written to Slot 0. If multiple chassis are being used, only the appropriate slot in the chassis whose address corresponds to the written chassis number will be selected. When no communication is taking place between the data acquisition board and any modules, write zero to the Slot-Select Register to ensure that no accidental writes occur.

Figure 2-9 shows the timing requirements on the SERCLK and SERDATIN signals. You must observe these timing requirements for all communications. T_{delay} is a specification of the SCXI-1160.

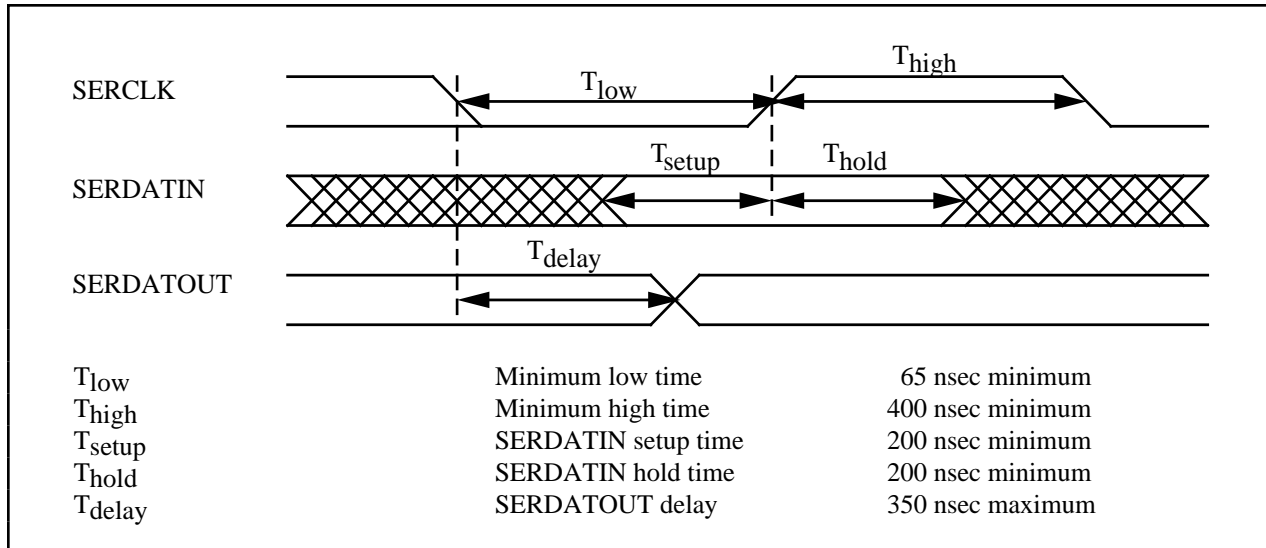

Figure 2-9. Serial Data Timing Diagram

After selecting the module slot as previously described, you must write first to the Address Handler, then to the register of interest for each write or read cycle to the module.

To write to the Address Handler, follow these steps:

- Initial conditions:

SS^* asserted low.
 $SERDATIN$ = don't care.
 $DAQD^*/A = 1$ (indicates data will be written to the Address Handler).
 $SLOT0SEL^* = 1$.
 $SERCLK = 1$ (and has not transitioned since SS^* went low).

- For each bit, starting with the MSB, perform the following action:

Establish the desired $SERDATIN$ level corresponding to this bit.
 $SERCLK = 0$.
 $SERCLK = 1$. This rising edge clocks the data.

These bits are the address of the register of interest.

3. Pull DAQD*/A low to deselect the Address Handler and select the register whose address was written to the Address Handler. This selects a register for writing to or reading from.

Figure 2-10 illustrates a write to the SCXI-1160 Address Handler of the binary pattern:

0 0 0 0 0 0 0 0 0 0 0 0 0 0 0 1

This pattern is the address of the Data Register.

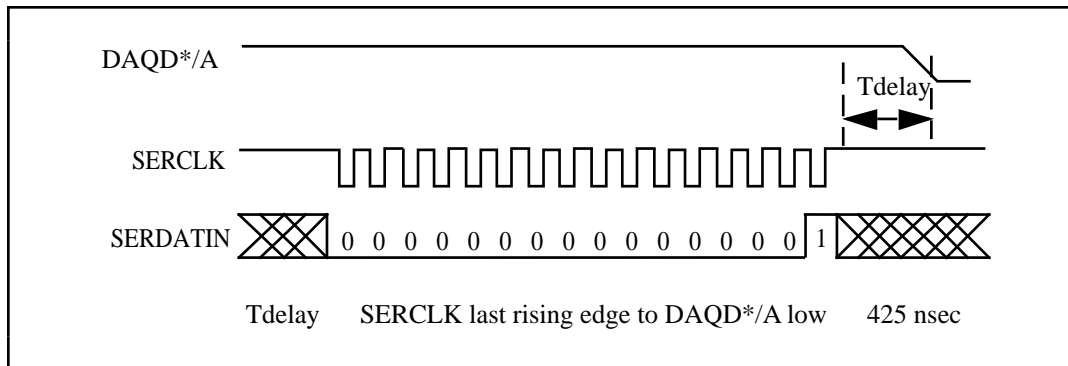

Figure 2-10. Address Handler Timing Diagram

After the Address Handler has been written to, an address line of a register has been asserted. Now you can write to the SCXI-1160 Data Register and read from its Module ID Register or Status Register using the following protocols. The contents of the Module ID Register are reinitialized by deasserting Slot-Select. After the 32 bits of data are read from the Module ID Register, further data will be zeros until reinitialization occurs. The Status Register bit value is updated at the time the relays switch, and remains low until the relays finish switching.

To write to the Data Register, follow these steps:

1. Initial conditions:

- SS* asserted low.
- SERDATIN = don't care.
- DAQD*/A = 0 (indicates data will be written to a register).
- SLOT0SEL* = 1.
- SERCLK = 1 (and has not transitioned since DAQD*/A went low).

2. For each bit to be written:

- Establish the desired SERDATIN level corresponding to this bit.
- SERCLK = 0.
- SERCLK = 1. This rising edge clocks the data.

3. Pull DAQD*/A high. This disables further writes to the module Data Register. If you wish, you can write address FFFF (hexadecimal) to the Address Handler. This selects the Parking Register and makes the module registers more immune to noise.

4. Pull SLOTOSEL* low to deassert the SS* line and establish conditions for writing a new slot-select number to the Slot 0 Slot-Select Register.
5. If you are not selecting another slot, write zero to the Slot 0 Slot-Select Register.

Figure 2-11 illustrates a write to the SCXI-1160 Data Register of the binary pattern:

10000111 00001111 00000000 00000000

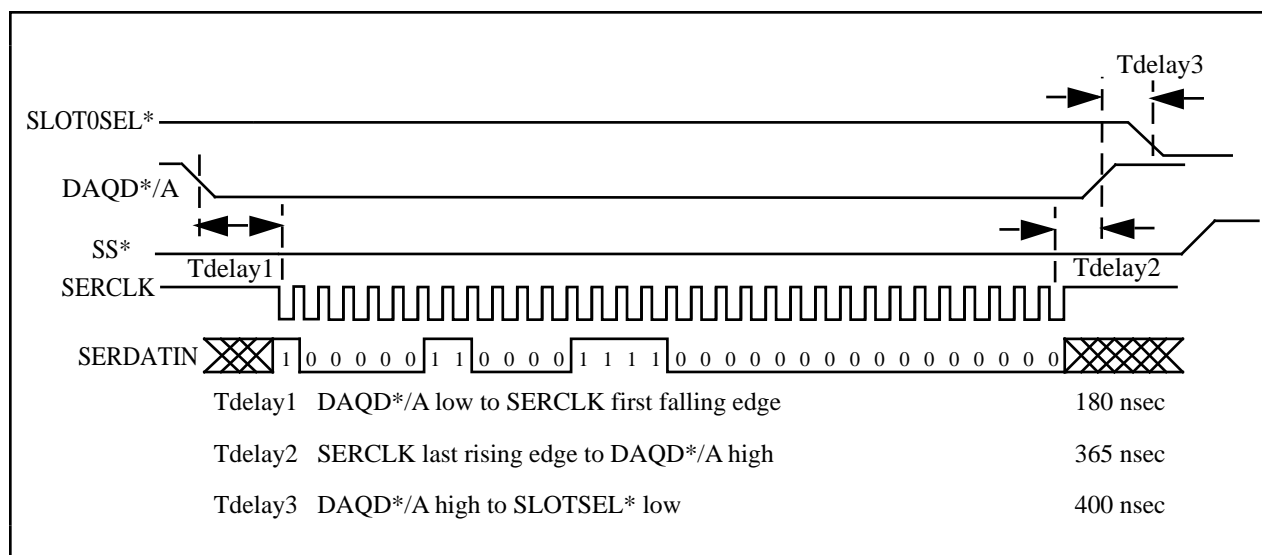

Figure 2-11. Data Register Write Timing Diagram

To read from the Module ID Register, follow these steps:

1. Initial conditions:

SS* asserted low.
 SERDATIN = don't care.
 DAQ*/A = 0.
 SLOTOSEL* = 1.
 SERCLK = 1 (and has not changed since DAQ*/A went low).

2. For each bit to be read:

Set SERCLK = 0.
 SERCLK = 1. This rising edge clocks the data.
 Read the level of the SERDATOUT line.

3. Pull DAQ*/A high. This disables further reads from the Module ID Register. If you wish, you can write address FFFF (hexadecimal) to the Address Handler. This selects the Parking Register and makes the module registers more immune to noise.

4. Pull SLOTOSEL* low to deassert the SS* line and establish conditions for writing a new slot-select number to the Slot 0 Slot-Select Register.
5. If you are not selecting another slot, write zero to the Slot 0 Slot-Select Register.

Figure 2-12 illustrates a read of the SCXI-1160 Module ID Register.

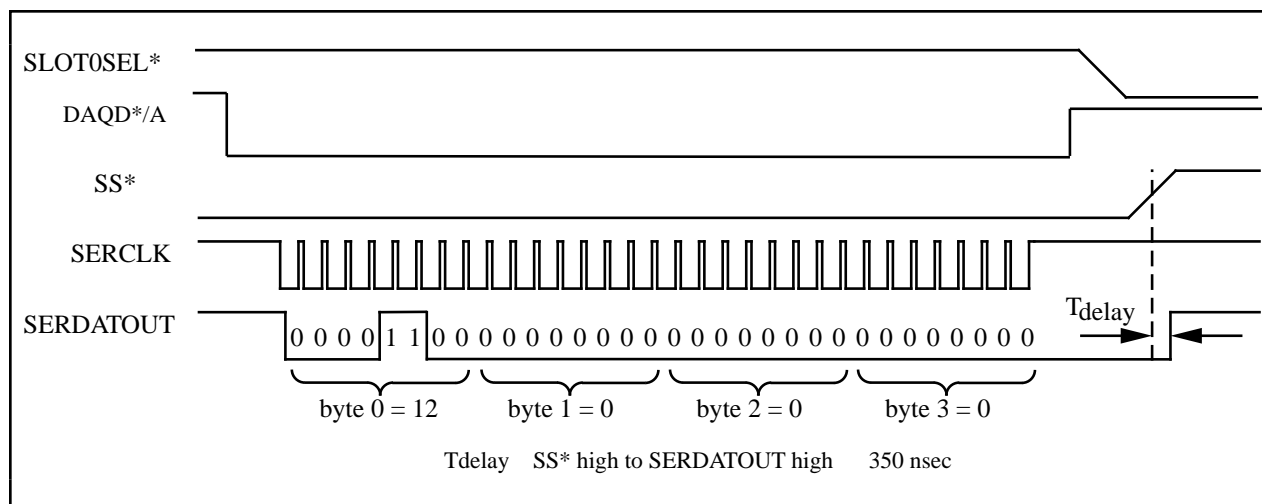

Figure 2-12. SCXI-1160 Module ID Register Timing Diagram

To read from the Status Register, follow these steps:

1. Initial conditions:

- SS* asserted low.
- SERDATIN = don't care.
- DAQD*/A = 0.
- SLOTOSEL* = 1.
- SERCLK = 1 (and has not changed since DAQD*/A went low).

2. The Status Register of the SCXI-1160 consists of a single bit that the relays control. You do not need to pulse the SERCLK to read the Status Register:

- Read the level of the SERDATOUT line. If it is low, the relays are switching. If it is high, the relays are finished switching.

3. Pull DAQD*/A high. This disables further reads from the Status Register. If you wish, you can write address FFFF (hexadecimal) to the Address Handler. This selects the Parking Register and makes the module registers more immune to noise.

4. Pull SLOTOSEL* low to deassert the SS* line and establish conditions for writing a new slot-select number to the Slot 0 Slot-Select Register.

5. If you are not selecting another slot, write zero to the Slot 0 Slot-Select Register.

Figure 2-13 illustrates a read of the SCXI-1160 Status Register after the relays have switched states.

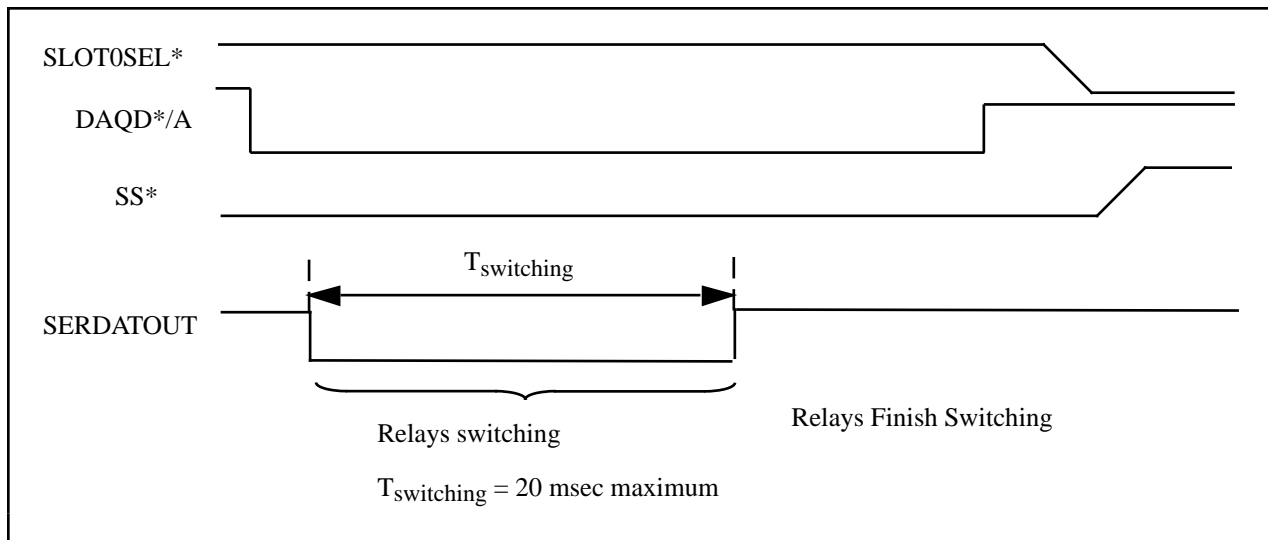

Figure 2-13. SCXI-1160 Status Register Timing Diagram

For further details on programming these signals, refer to Chapter 5, *Programming*.

Chapter 3

Theory of Operation

This chapter contains a functional overview of the SCXI-1160 module and explains the operation of each functional unit making up the SCXI-1160.

Functional Overview

The block diagram in Figure 3-1 illustrates the key functional components of the SCXI-1160.

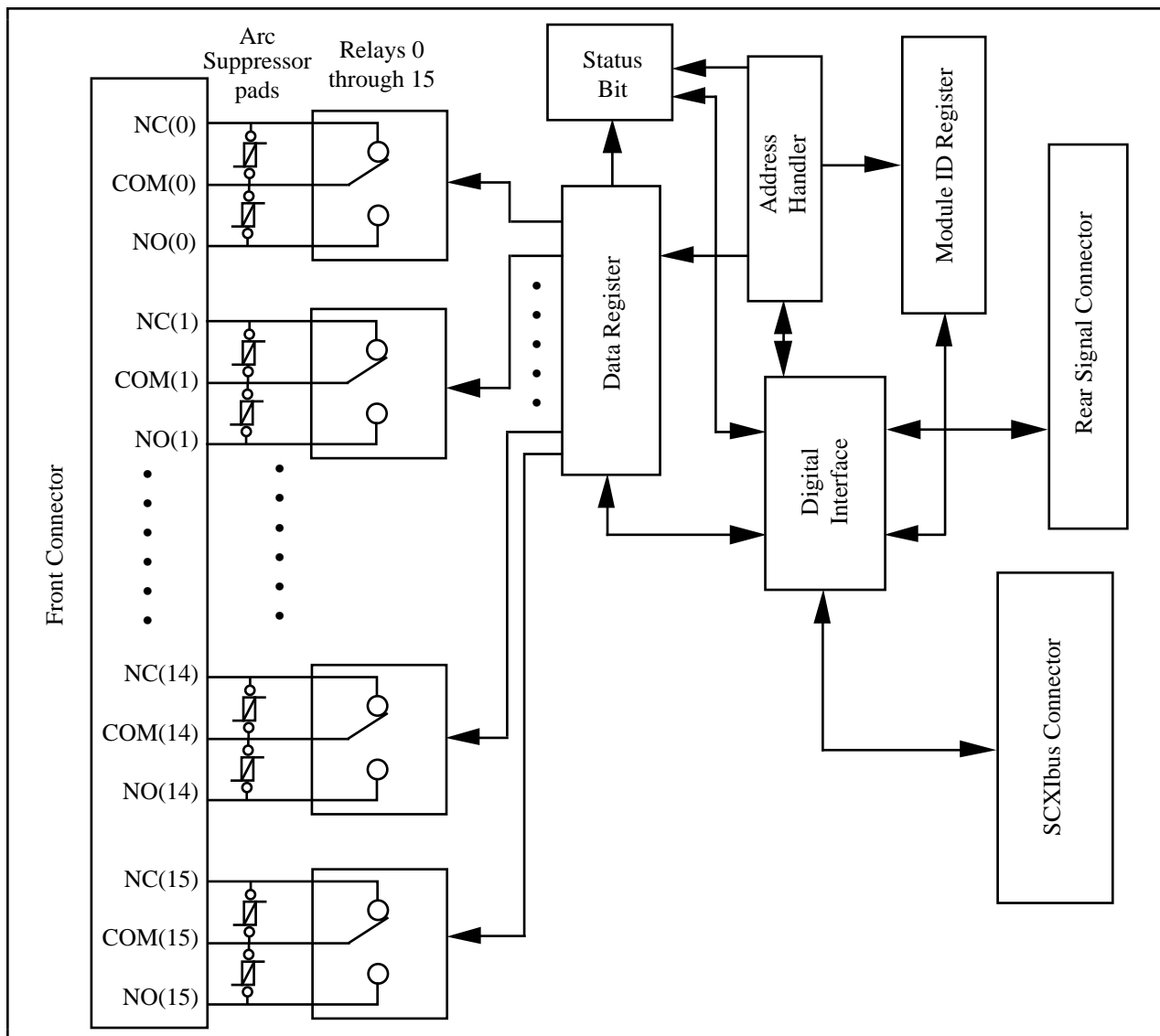

Figure 3-1. SCXI-1160 Block Diagram

The major components of the SCXI-1160 are as follows:

- SCXIBus connector
- Digital interface
- Digital control circuitry
- Relay channels

The SCXI-1160 module is dedicated to switching and controlling power and low-level signal sources. The theory of operation of each of the SCXI-1160 components is explained in the rest of this chapter.

SCXIBus Connector

Figure 3-2 shows the pinout of the SCXIBus connector.

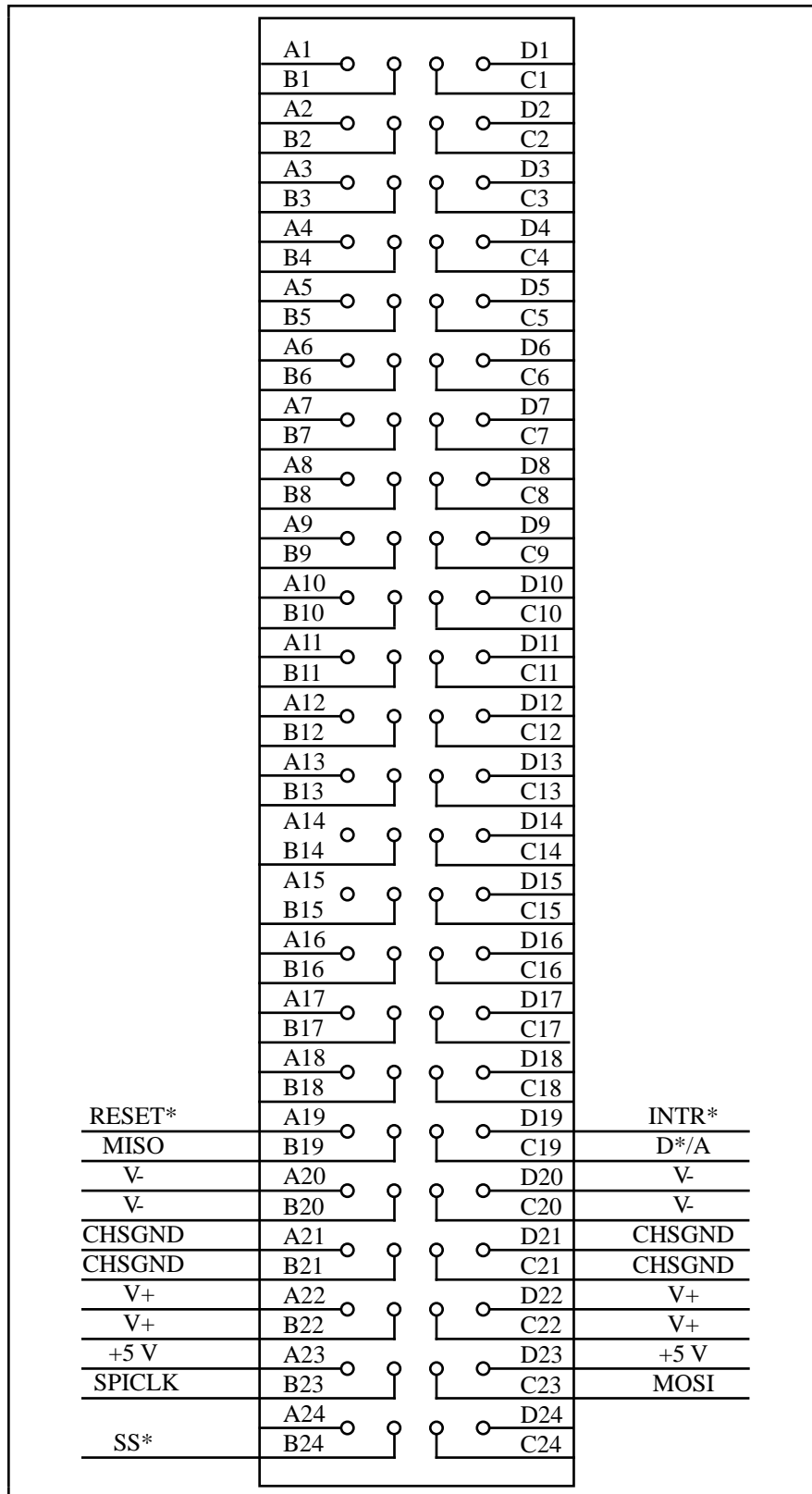

Figure 3-2. SCXibus Connector Pin Assignment

SCXIBus Connector Signal Descriptions

Pin	Signal Name	Description
A21, B21, C21, D21	CHSGND	Chassis Ground – Digital and analog ground reference.
A19	RESET*	Reset – When pulled low, reinitializes the module to its power-up state. Totem pole. Input.
B19	MISO	Master-In-Slave-Out – Transmits data from the module to the SCXIBus. Open collector. I/O.
C19	D*/A	Data/Address – Indicates to the module whether address information or data information is being sent to the module on MOSI. Open collector. I/O.
D19	INTR*	Interrupt – Active low. Causes data that is on MOSI to be written to the Slot-Select Register Slot 0. Open collector. Output.
A20, B20, C20, D20	V-	Negative Analog Supply – -18.5 to -25 V.
A22, B22, C22, D22	V+	Positive Analog Supply – +18.5 to +25 V.
A23, D23	+5 V	+5 VDC Source – Digital power supply.
B23	SPICLK	Serial Peripheral Interface (SPI) Clock – Clocks the serial data on the MOSI and MISO lines. Open collector. I/O.
C23	MOSI	Master-Out-Slave-In – Transmits data from the SCXIBus to the module. Open collector. I/O.
B24	SS*	Slot Select – When low, enables module communication over the SCXIBus. Totem pole. Input.

All other pins are not connected.

MOSI, MISO, SPICLK, and SS* form a synchronous communication link that conforms with SPI using an idle-high clock and second-edge data latching. D*/A, INTR*, and RESET* are additional control signals.

When the module is in an SCXI-1000 or SCXI-1001 chassis, the data acquisition board, via the module rear signal connector, must tap into the open-collector backplane signal lines as a master to write to the module. The signal connections from the rear signal connector to the backplane are shown in Table 3-1.

Table 3-1. SCXIBus Equivalents for the Rear Signal Connector

Rear Signal Connector Signal	SCXIBus Equivalent
SERDATIN	MOSI
DAQD*/A	D*/A
SLOT0SEL*	INTR*
SERCLK	SPICLK
SERDATOUT	MISO Jumper W5 must be set to position 1

The SCXI-1160 module converts the data acquisition board signals to open-collector signals on the backplane of the SCXI chassis. For the data acquisition board to talk to a slot, the board must first assert the SS* for that slot. To do this, assert INTR* low, write a 16-bit number over MOSI corresponding to the desired slot (and chassis if you are using an SCXI-1001 chassis), and then release INTR* high. At this point, the SS* of the desired slot is asserted low and the data acquisition board can communicate with the module in that slot according to the SPI protocol.

Digital Interface

Figure 3-3 shows a diagram of the SCXI-1160 and SCXIBus digital interface circuitry.

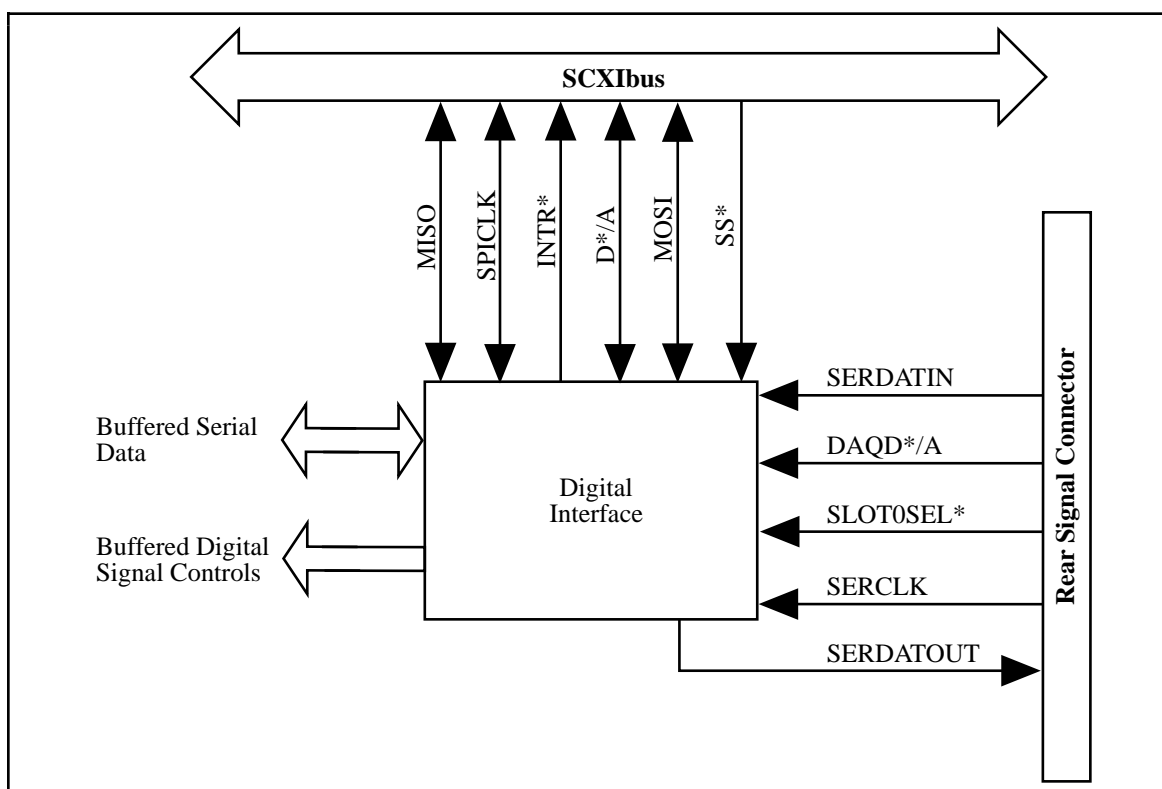

Figure 3-3. Digital Interface Circuitry Block Diagram

The digital interface circuitry is divided into a data acquisition section and an SCXIbus section. The SCXI-1160 connects to the SCXIbus via a 4x24 metal receptacle and to the data acquisition board via a 50-pin ribbon-cable header. The digital interface circuitry buffers the digital signals from the data acquisition board and the SCXIbus and sends signals back and forth between the data acquisition board and the SCXIbus.

Digital Control Circuitry

Figure 3-4 diagrams the SCXI-1160 digital control.

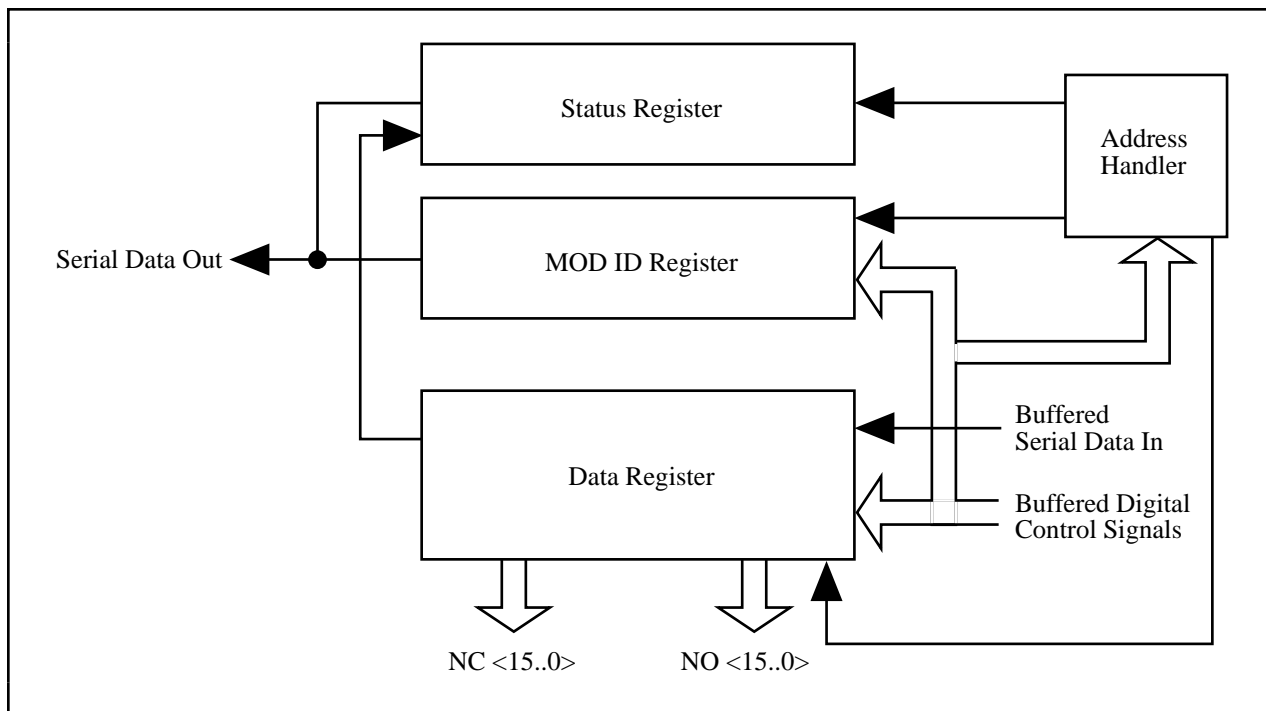

Figure 3-4. SCXI-1160 Digital Control

The digital control section consists of the Address Handler, the Data Register, the Module ID Register, and the Status Register.

The Address Handler is the register to which you first write an address to specify with which write or read register you want to communicate. The Address Handler is a two-byte, serial-in, parallel-out register with address decoding. Refer to the *Timing Requirements and Communication* section in Chapter 2, *Configuration and Installation*, and to Chapter 4, *Register Descriptions*, for further details.

The Data Register is a four-byte, serial-in, parallel-out shift register with relay drive capabilities. Data is received on the MOSI line from either Slot 0 or the data acquisition board when SS* is enabled, D*/A indicates data transfer (D*/A low), and the Data Register address is selected in the

Address Handler. The Data Register controls the state of the SCXI-1160 relays. The complete descriptions of the register bits are given in Chapter 4, *Register Descriptions*. Writes to the Data Register require the following steps:

1. SS* goes low, enabling communication with the board.
2. Write 0001 (hexadecimal) to the Address Handler. This selects the Data Register.
3. D*/A goes low, indicating that the information sent on the MOSI line is data.
4. The serial data is available on MOSI and SPICLK clocks it into the register.
5. SS* goes high and D*/A goes high, indicating the end of communication. This action latches the Data Register bits.

At reset time or at power up, the state of the Data Register and relays is unknown. To set the relays to a known state, perform a write to the Data Register.

Note: If a power loss or a reset occurs, the state of the relays is unchanged.

The Module ID Register connects to MISO on the SCXIbus. The Module ID Register is an 8-bit parallel serial-in, serial-out shift register and an SPI communication adapter. The contents of the Module ID Register are written onto MISO during the first four bytes of transfer after selecting the Module ID Register in the Address Handler. Zeros are written to MISO thereafter until the Module ID Register is deselected. The SCXI-1160 module ID is hex C.

The Status Register is a 1-bit register that indicates whether or not the relays are switching.

Relay Channels

The SCXI-1160 consists of 16 independent one form C relays. Each relay has three connections at the front connector—the common (COM), the normally closed (NC), and the normally open (NO) positions, which are available at each relay. To protect the relay contacts from inductive loads, arc suppressors may be installed at the pads, which are at each relay. Refer to the *Contact Protection for Inductive Load Connections* section of Chapter 2, *Configuration and Installation*, for further details on contact protection.

All 16 relays are two-coil latching relays. One coil is for resetting and the other is for setting the relay. The Data Register controls the relays as follows. The 16 LSBs of the Data Register control the set coils. When the set coil is energized, the COM position connects to the NO position. The 16 MSBs of the Data Register control the reset coils. When the reset coil is energized, the COM connects to the NC position. *Never* energize both coils at the same time.

After a write to the Data Register, all relay coils are driven for a period of time (20 msec maximum) to ensure that the relays have switched states. Then the Data Register outputs go to a high-impedance state; this ensures that the heating effect of the relay coils is minimal, thus reducing the thermal electromotive force (emf) that may be generated across the contacts.

Each relay can be set (the relay COM position connected to the NO position) or reset (the relay COM position connected to the NC position) without affecting the other relays, or all relays can change states at the same time. However, each time a relay changes its state, the Data Register is rewritten to. To reduce power consumption, thermal emf, and help extend the relay life, it is

advisable to avoid energizing the relay coils that will not be changing states. To achieve this, write zeros in the Data Register locations belonging to the relays that do not need to change states. Refer to Chapter 4, *Register Descriptions*, and Chapter 5, *Programming*, for further details.

The relays are break-before-make, as long as you do not exceed the specified relay operation speed. In addition, each relay is fully isolated from the other relays and from earth ground, with a working common-mode voltage of 250 Vrms and a breakdown of 1,500 Vrms.

Note: It is important to notice that this module has no access to the analog backplane; this protects the backplane from faults when high voltages are available on the relay contacts.

Chapter 4

Register Descriptions

This chapter describes in detail the SCXI-1160 Address Handler, the Module ID Register, the Data Register, the Status Register, and the Slot 0 registers.

Note: If you plan to use a programming software package such as NI-DAQ, LabWindows, or LabVIEW with your SCXI-1160 board, you do not need to read this chapter.

Register Description

Register Description Format

This register description chapter discusses each of the SCXI-1160 registers and the Slot 0 registers. A detailed bit description of each register is given. The individual register description gives the type, word size, and bit map of the register, followed by a description of each bit.

The register bit map shows a diagram of the register with the MSB shown on the left (bit 31 for a 32-bit register, bit 15 for a 16-bit register, and bit 7 for an 8-bit register) and the LSB shown on the right (bit 0). A rectangle is used to represent each bit. Each bit is labeled with a name inside its rectangle. An asterisk (*) after the bit name indicates that the bit is inverted (negative logic). The Module ID register has a unique format and is described in the *Module ID Register* section.

In many of the registers, several bits are labeled with an X, indicating don't care bits. When you write to a register, you may set or clear these bits without effect.

SCXI-1160 Registers

The SCXI-1160 is a class II module. It has four registers and an address handler. The Module ID Register is a 4-byte, read-only register that contains the Module ID number of the SCXI-1160. The Data Register is a 32-bit, write-only register that controls the relay states on the SCXI-1160. The Status Register is a 1-bit, read-only register that indicates the state of the relays as either switching or finished switching. The Parking Register is a dummy register located at address FFFF. The Address Handler is the register that contains the address of the register to be read from or written to, and is a write-only register.

Address Handler

You must write to the Address Handler at the beginning of each write or read from the SCXI-1160. Write the address of the register of interest to this handler, which in turn enables the register of interest. The Address Handler is two bytes long and contains the address of the register to be read from or written to. The Address Handler is selected when SS* is asserted low and D*/A indicates an address transfer (D*/A is high). At this time, the address is shifted in the Address Handler Register, MSB first. Table 4-1 contains a list of register addresses.

Table 4-1. Register Addresses

Address (Hexadecimal)	Register
0000	Module ID Register
0001	Data Register
0002	Status Register
0003-FFFE	Reserved
FFFF	Parking Register

After you are finished writing, the D*/A line goes low, indicating a data transfer to a register. This enables the Address Handler output and selects the appropriate register.

At the end of each communication with the Module ID Register, the Data Register, or the Status Register, select the Parking Register (write address FFFF to the Address Handler). This increases the noise immunity of the module when it is in its quiescent state.

After you select the Parking Register, SS* should go high, deselecting the modules and latching all the data.

At reset or at power up, the Address Handler content is cleared.

Module ID Register

The Module ID register contains the 4-byte module ID code for the SCXI-1160. This code number is read on the MISO line whenever the Module ID register is accessed. The bytes appear least significant byte first. Within each byte, data is sent out MSB first. Additional data transfers result in all zeros being sent on the MISO line. The Module ID register is reinitialized to its original value each time it is deselected or at reset or power up. The Module ID Register address is hexadecimal 0000.

Type: Read-only

Word Size: 4-byte

Bit Map:

Byte 0

7	6	5	4	3	2	1	0
0	0	0	0	1	1	0	0

Byte 1

7	6	5	4	3	2	1	0
0	0	0	0	0	0	0	0

Byte 2

7	6	5	4	3	2	1	0
0	0	0	0	0	0	0	0

Byte 3

7	6	5	4	3	2	1	0
0	0	0	0	0	0	0	0

Data Register

The Data Register contains 32 bits that control the state of each relay of the SCXI-1160. Whenever the Address Handler selects the Data Register, the Data Register shifts in the data present on the MOSI line, bit 31 first, and then latches the data when it is deselected. At power up or reset, the Data Register content is unknown and its outputs are not driving the relay coils. The Data Register address is hexadecimal 0001. Table 4-2 shows a truth table for setting and resetting a given relay.

Table 4-2. Truth Table for Resetting and Setting Relays

NC(x) (Reset)	NO(x) (Set)	Function
0	0	No change
0	1	COM connects to NO position
1	0	COM connects to NC position
1	1	<i>Not valid</i>

Type: Write-only

Word Size: 32-bit

Bit Map:

31	30	29	28	27	26	25	24
NC(15)	NC(14)	NC(13)	NC(12)	NC(11)	NC(10)	NC(9)	NC(8)
23	22	21	20	19	18	17	16
NC(7)	NC(6)	NC(5)	NC(4)	NC(3)	NC(2)	NC(1)	NC(0)
15	14	13	12	11	10	9	8
NO(15)	NO(14)	NO(13)	NO(12)	NO(11)	NO(10)	NO(9)	NO(8)
7	6	5	4	3	2	1	0
NO(7)	NO(6)	NO(5)	NO(4)	NO(3)	NO(2)	NO(1)	NO(0)

Bit	Name	Description
31-16	NC<15..0>	Normally Closed (x) – These bits determine the state of the relays. If set to 0, the relays stay in their previous positions or respond to the NO(x) state. If set to 1 and the NO(x) is set to 0, the NO position on the relay opens and the COM connects to the NC position.
15-0	NO<15..0>	Normally Open (x) – These bits determine the state of the relays. If set to 0, the relays stay in their previous positions or respond to the NC(x). If set to 1 and the NC(x) is set to 0, the NC position on the relay opens and the COM connects to the NO position.

Note: A value of NC(x) = 1 and NO(x) = 1 is not valid. x indicates a given relay number.

Status Register

The Status Register is a 1-bit read-only register that is located at address 0002 (hexadecimal). When this bit is high, it indicates that the relays are finished switching and you can perform further operations. If this bit is low, the relays are still switching; wait until the status bit goes high again before you perform any further task with these relays.

After each write operation to the Data Register, it is recommended that you poll and check the Status Register. Select the Status Register in the same manner as the other two registers by writing its address to the Address Handler. If you do not want to poll the Status Register, you must make sure that at least 20 msec have elapsed since the last write to the Data Register before you perform any new operations on the relays.

At reset or power up, the Status Register bit is set high (relays are not switching).

Parking Register

This register is a dummy register that you should select after the end of a read or write operation. Selecting the Parking Register places the module in a state insensitive to noise and to ESD, which may corrupt the Data Register content and cause the relays to change state.

Select the Parking Register by writing FFFF (hexadecimal) to the Address Handler.

Slot 0 Register Descriptions

Slot 0 has three registers—the FIFO Register, the Hardscan Register and the Slot-Select Register. Only the Slot-Select Register is of interest. The Slot-Select Register is a 16-bit, write-only register that determines with which slot the data acquisition board speaks when SLOT0SEL* is released high. In the case of the SCXI-1001 chassis, the Slot-Select Register also determines in which chassis the desired slot is. Write to the Slot-Select Register using the SLOT0SEL* line. Maintain software copies of the Slot-Select Register.

If you are using multiple chassis, it is important to understand the architecture of the Slot-Select Register. Although each chassis has its own physical Slot-Select Register, all are written to at the same time. The jumper settings in Slot 0 of a chassis determine with which chassis number Slot 0 is identified. From the software perspective, only one Slot-Select Register exists in a system composed of multiple chassis.

Slot-Select Register

The Slot-Select Register contains 16 bits that determine which module in which chassis is enabled for communication when the SLOTOSEL* line is high. An SCXI-1000 chassis selects the appropriate module in its chassis, regardless of the chassis number written. The Slot-Select Register shifts in the data present on the MOSI line, bit 16 first, when SLOTOSEL* is low.

Type: Write-only

Word Size: 16-bit

Bit Map:

15	14	13	12	11	10	9	8
X	X	X	X	X	X	X	CHS4
7	6	5	4	3	2	1	0
CHS3	CHS2	CHS1	CHS0	SL3	SL2	SL1	SL0

Bit	Name	Description
15-9	X	Don't care bits – Unused.
8-4	CHS<4..0>	Chassis Bit 4 through 0 – These bits determine which chassis is selected. On the SCXI-1000 chassis, these are don't care bits.
3-0	SL<3..0>	Slot Bit 3 through 0 – These bits determine which slot in the selected chassis is selected.

Chapter 5

Programming

This chapter contains a functional programming description of the SCXI-1160 and Slot 0.

Note: If you plan to use a programming software package such as NI-DAQ, LabWindows, or LabVIEW with your SCXI-1160 board, you do not need to read this chapter.

Programming Considerations

Programming the SCXI-1160 involves writing to the Data Register. Programming the data acquisition boards involves writes to their registers. See your data acquisition board user manual for more information. The programming instructions list the sequence of steps to take. The instructions are language independent; that is, they instruct you to write a value to a given register without presenting the actual code.

Notation

For the bit patterns to be written, the following symbols are used:

0	binary zero
1	binary one
X	don't care; either zero or one may be written

The bit patterns are presented MSB first, left to right.

Register Writes

This section describes how to write to the Data Register including the procedure for writing to the Slot-Select Register to select the appropriate slot. For timing specifics, refer to the *Timing Requirements and Communication Protocol* section in Chapter 2, *Configuration and Installation*. The rear signal connector pin equivalences to the different National Instruments data acquisition boards are given in Table 5-1. See also Appendix E, *SCXI-1160 Cabling*. The Data Register is a write-only register.

The different bits in this register control independent relays. There are times when you may want to set or reset a specific relay or relays without affecting the remaining relays. However, a write to the Data Register affects all relays simultaneously. You cannot read the register to determine which relays have been set or reset in the past; therefore, you should maintain a software copy of the relay states. You can then read the software copy to determine the status of the relays. To change the state of a single relay without disturbing the remaining relays, change the bits that control the relay coils of interest, clear all other bits (no change in states), and rewrite to the Data Register.

Table 5-1. SCXibus to SCXI-1160 Rear Signal Connector to Data Acquisition Board Pin Equivalences

SCXibus Line	SCXI-1160 Rear Signal Connector	MIO-16	Lab-NB/Lab-PC/ Lab-PC+/Lab-LC	PC-LPM-16	DIO-24	DIO-96	DIO-32F
MOSI	SERDATIN	ADIO0	PB4	DOOUT4	PB3	APB3	DIOB3
D*/A	DAQD*/A	ADIO1	PB5	DOOUT5	PB2	APB2	DIOB2
INTR*	SLOT0SEL*	ADIO2	PB6	DOOUT6	PB1	APB1	DIOB1
SPICLK	SERCLK	EXTSTROBE*	PB7	DOOUT7	PB0	APB0	DIOB0
MISO	SERDATOUT	BDIO0	PC1	DIN6	PA0	APA0	DIOA0

Register Selection and Write Procedure

1. Select the slot of the module to be written to. Initial conditions:

SERDATIN = X.
 DAQD*/A = 1.
 SLOT0SEL* = 1.
 SERCLK = 1.

2. Clear SLOT0SEL* to 0. This deasserts all SS* lines to all modules in all chassis.
3. For each bit, starting with the MSB (bit 15), do the following:
 - a. Set SERDATIN = bit to be sent. These bits are the data that is written to the Slot-Select Register.
 - b. Clear SERCLK to 0.
 - c. Set SERCLK to 1. This rising edge clocks the data. If you are using an MIO-16 board, writing to the EXTSTROBE* register pulses EXTSTROBE* low and then high, accomplishing steps 3b and 3c.
4. Set SLOT0SEL* to 1. This asserts the SS* line of the module whose slot number was written to Slot 0. If you are using multiple chassis, only the appropriate slot in the chassis whose address corresponds to the written chassis number is automatically selected. When no communication is taking place between the data acquisition board and any modules, write zero to the Slot-Select Register to ensure that no accidental writes occur.

5. If you are writing to a Data Register, you must first write to the Address Handler address 0001 (hexadecimal):
 - a. Establish the desired SERDATIN level corresponding to this bit.
 - b. Clear SERCLK to 0.
 - c. Set SERCLK to 1 (clock the data). If you are using an MIO-16 board, writing to the EXTSTROBE* register pulses EXTSTROBE* low and then high, accomplishing steps 5b and 5c.
 - d. After you have written all the address bits, clear DAQD*/A to 0. This selects the Data Register and the data on the MOSI line is written to it.
6. For each bit to be written to the Data Register:
 - a. Establish the desired SERDATIN level corresponding to this bit.
 - b. Clear SERCLK to 0.
 - c. Set SERCLK to 1 (clock the data). If you are using an MIO-16 board, writing to the EXTSTROBE* register pulses EXTSTROBE* low and then high, accomplishing steps 6b and 6c.
 - d. After clocking the last data bit, if you do not want to write to or read another register, write hexadecimal address FFFF to the Address Handler to increase noise immunity of the module when it is in the quiescent state. This also latches the data into the Data Register. Selecting another register also latches the data in the Data Register.
7. Pull SLOT0SEL* low to deassert the SS* line and establish conditions for writing a new slot-select number to the Slot 0 Slot-Select Register.
8. If you are not selecting another slot, write zero to the Slot 0 Slot-Select Register. If you are selecting another slot, repeat the procedure starting at step 3.

For a timing illustration of a Data Register write, see Figure 2-11, *Data Register Write Timing Diagram*.

Initialization

The SCXI-1160 powers up with its Data Register content unknown. If you reset the chassis, the Data Register content stays unchanged and the relays maintain their previous states.

Examples

This section describes how to program the SCXI-1160, either alone or in conjunction with other modules.

The following examples are intended to aid your understanding of module and Slot 0 programming. It will be helpful to refer to the bit descriptions for the Data Register, Status Register, and Address Handler in Chapter 4, *Register Descriptions*.

Example 1

You want to set all the relays in their NC position that are connected to their COM position on an SCXI-1160 in Slot 1 of an SCXI-1000 chassis. The SCXI-1160 is directly cabled to a data acquisition board.

The programming steps are as follows:

1. Select the Status Register and check to make sure the relays are not switching. Refer to Chapter 4, *Register Descriptions*, and to the section *Timing Requirements and Communication Protocol* in Chapter 2, *Configuration and Installation*.
2. Following the procedure given in the *Register Writes* section of this chapter, write 11111111 11111111 00000000 00000000 to the Data Register of the SCXI-1160 in Slot 1.

Example 2

An SCXI-1000 chassis has four SCXI-1160 modules in Slots 1, 2, 3, and 4. The SCXI-1160 in Slot 4 is cabled to the data acquisition board. You want to connect the NO position to the COM position on all of the modules and leave all the other channels unchanged. The channels of interest in each slot are as follows:

- Channel 3 on the SCXI-1160 in Slot 1
- Channels 0 through 2 on the SCXI-1160 in Slot 4
- Channels 10, 7, 5, and 3 on the SCXI-1160 in Slot 3

The programming steps are as follows:

1. Following the procedure given in the *Register Writes* section of this chapter, write 00000000 00000000 00000000 00001000 to the Data Register of the SCXI-1160 in Slot 1.
2. Following the procedure given in the *Register Writes* section of this chapter, write 00000000 00000000 00000000 00000111 to the Data Register of the SCXI-1160 in Slot 4.
3. Following the procedure given in the *Register Writes* section of this chapter, write 00000000 00000000 00000100 10101000 to the Data Register of the SCXI-1160 in Slot 3.

Example 3

You have a multichassis system with an SCXI-1160 in Slot 4 of chassis 1, and another SCXI-1160 in Slot 11 of chassis 2. You want to do the following:

1. In chassis 1, connect the NC position to the COM position on channels 1, 5, and 8, and connect the NO position to the COM position on channels 3 and 4.
2. In chassis 2, connect the NC position to the COM position on channels 0 through 7, and connect the NO position to the COM position on channels 8 through 15.

Leave all other channels unchanged.

Assuming that the modules are correctly cabled and jumpers W5 and W1 are correctly set, do the following:

1. Select chassis 1, Slot 4 as described in the *Register Writes* section of this chapter.
2. Following the procedure given in the *Register Writes* section of this chapter, write 00000001 00100010 00000000 00011000.
3. Select chassis 2, Slot 11 as described in the *Register Writes* section of this chapter.
4. Following the procedure given in the *Register Writes* section of this chapter, write 00000000 11111111 11111111 00000000.

Appendix A

Specifications

This appendix lists the specifications for the SCXI-1160. These are typical at 25° C and 50% humidity unless otherwise stated. The operating temperature range is 0° to 50° C.

Contact Ratings

Switching power (resistive load)

AC	500 VA maximum
DC	60 W maximum for $V \leq 30$ V
	30 W maximum for $V > 30$ V

Switching voltage 250 VAC or 48 VDC maximum

Switching current 2 A maximum per channel

Channel on resistance	75 m Ω
Minimum switching capacity	100 μ A at 100 mVDC
Contact material	Gold-clad silver alloy

Life

Note: Relays are subject to normal wear based on the number of operations.

Mechanical (at 50 cps)	10 ⁸ operations minimum
Electrical (at 20 cpm)	10 ⁵ at 2 A 250 VAC
	2x10 ⁵ at 2 A 30 VDC

Working isolation

Terminal to terminal	250 Vrms ¹
Terminal to earth	250 Vrms

Offset voltage 3 μ V typical

Maximum speed 20 operations per minute at maximum load
50 operations per second at low-level loads
(1 mA 1 VDC)

Set and reset time 10 msec

¹ Module tested following the UL 1244 standard to twice the working voltage +1000 Vrms.

Physical

Dimensions	1.2 by 6.8 by 8.0 in.
Connectors	50-pin male ribbon-cable rear connector 48-pin DIN C male front connector (48-screw terminal adapter available)

Operating Environment

Temperature	0° to 50° C
Relative humidity	5% to 90% at 35° C

Storage Environment

Temperature	-55° to 150° C
Relative humidity	5% to 90% noncondensing

Appendix B

Rear Signal Connector

This appendix describes the pinout and signal names for the SCXI-1160 50-pin rear signal connector, including a description of each connection.

Figure B-1 shows the pin assignments for the SCXI-1160 rear signal connector.

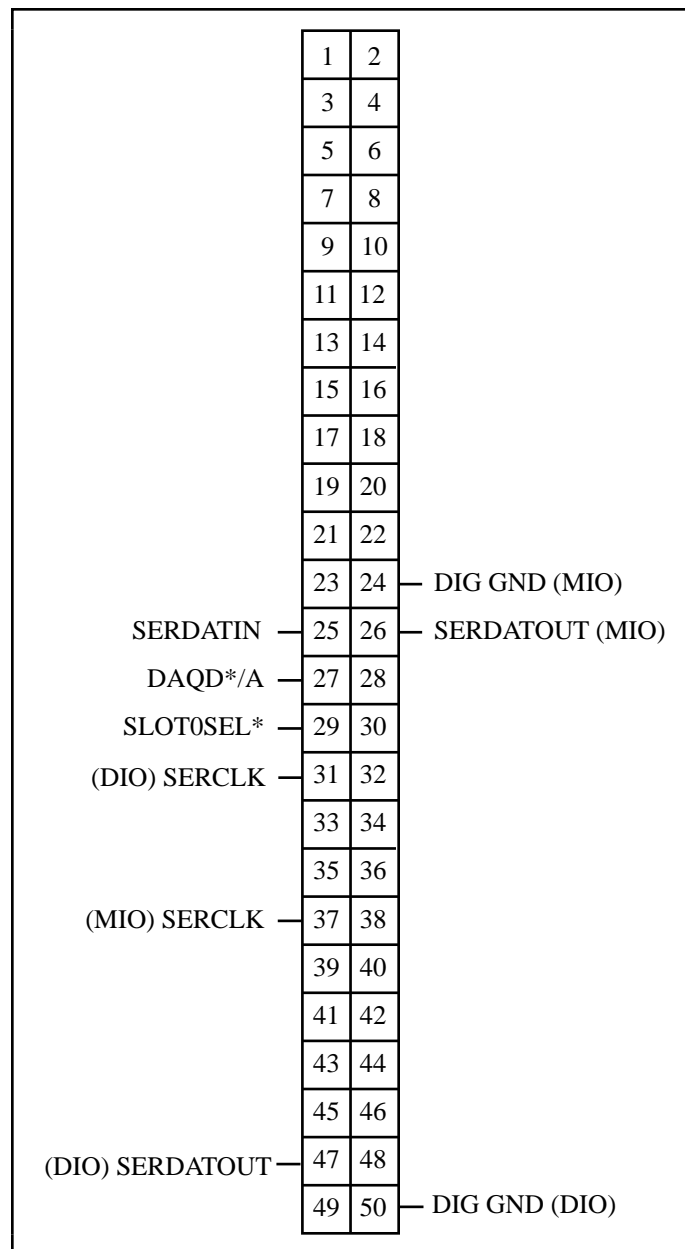

Figure B-1. SCXI-1160 Rear Signal Connector Pin Assignment

Rear Signal Connector Signal Descriptions

Pin	Signal Name	Description
24 or 50	DIG GND	Digital Ground – Supplies the reference for data acquisition board digital signals and is tied to the module digital ground. Pin 50 is for DIO boards. Pin 24 is for MIO boards and jumper W3 selects it.
25	SERDATIN	Serial Data In – Taps into the SCXIBus MOSI line to provide serial input data to a module or Slot 0.
26 or 47	SERDATOUT	Serial Data Out – Taps into the SCXIBus MISO line to accept serial output data from a module. Pin 47 is for DIO boards. Pin 26 is for MIO boards and jumper W2 selects it.
27	DAQD*/A	Data Acquisition Board Data/Address Line – Taps into the SCXIBus D*/A line to indicate to the module whether the incoming serial stream is data or address information.
29	SLOT0SEL*	Slot 0 Select – Taps into the SCXIBus INTR* line to indicate whether the information on MOSI is sent to a module or to Slot 0.
31 or 37	SERCLK	Serial Clock – Taps into the SCXIBus SPICLK line to clock the data on the MOSI and MISO lines. Pin 31 is for DIO boards. Pin 37 is for MIO boards and jumper W4 selects it.

See the *Timing Requirements and Communication Protocol* section in Chapter 2, *Configuration and Installation*, for more detailed information on timing.

Appendix C

SCXibus Connector

This appendix describes the pinout and signal names for the SCXI-1160 96-pin SCXibus connector, including a description of each connection.

Figure C-1 shows the pinout of the SCXI-1160 SCXibus connector.

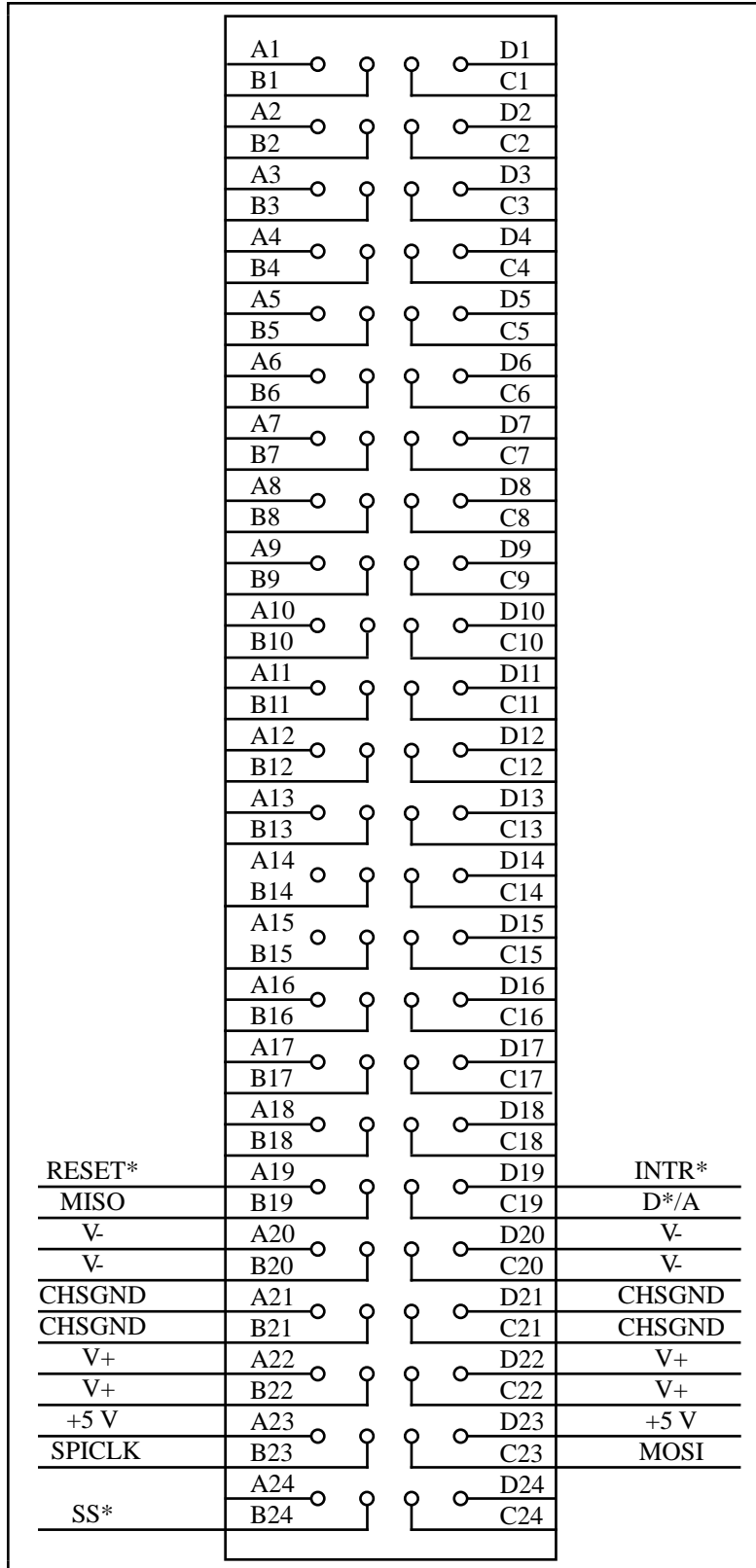

Figure C-1. SCXIbus Connector Pin Assignment

SCXIBus Connector Signal Descriptions

Pin	Signal Name	Description
A21, B21, C21, D21	CHSGND	Chassis Ground – Digital and analog ground reference.
A19	RESET*	Reset – When pulled low, reinitializes the module to its power-up state. Totem pole. Input.
B19	MISO	Master-In-Slave-Out – Transmits data from the module to the SCXIBus. Open collector. I/O.
C19	D*/A	Data/Address – Indicates to the module whether address information or data information is being sent to the module on MOSI. Open collector. I/O.
D19	INTR*	Interrupt – Active low. Causes data that is on MOSI to be written to the Slot-Select Register Slot 0. Open collector. Output.
A20, B20, C20, D20	V-	Negative Analog Supply – -18.5 to -25 V.
A22, B22, C22, D22	V+	Positive Analog Supply – +18.5 to +25 V.
A23, D23	+5 V	+5 VDC Source – Digital power supply.
B23	SPICLK	Serial Peripheral Interface (SPI) Clock – Clocks the serial data on the MOSI and MISO lines. Open collector. I/O.
C23	MOSI	Master-Out-Slave-In – Transmits data from the SCXIBus to the module. Open collector. I/O.
B24	SS*	Slot Select – When low, enables module communication over the SCXIBus. Totem pole. Input.

All other pins are not connected.

Further information is given in Chapter 3, *Theory of Operation*.

Appendix D

SCXI-1160 Front Connector

This appendix describes the pinout and signal names for the SCXI-1160 front connector, including a description of each connection.

Figure D-1 shows the pin assignments for the SCXI-1160 front connector.

Pin Number	Signal Name	Column			Signal Name
		A	B	C	
32	COM (0)	○			
31	NO (0)		○		○ NC (0)
30	COM (1)	○			
29	NO (1)		○		○ NC (1)
28	COM (2)	○			
27	NO (2)		○		○ NC (2)
26	COM (3)	○			
25	NO (3)		○		○ NC (3)
24	COM (4)	○			
23	NO (4)		○		○ NC (4)
22	COM (5)	○			
21	NO (5)		○		○ NC (5)
20	COM (6)	○			
19	NO (6)		○		○ NC (6)
18	COM (7)	○			
17	NO (7)		○		○ NC (7)
16	COM (8)	○			
15	NO (8)		○		○ NC (8)
14	COM (9)	○			
13	NO (9)		○		○ NC (9)
12	COM (10)	○			
11	NO (10)		○		○ NC (10)
10	COM (11)	○			
9	NO (11)		○		○ NC (11)
8	COM (12)	○			
7	NO (12)		○		○ NC (12)
6	COM (13)	○			
5	NO (13)		○		○ NC (13)
4	COM (14)	○			
3	NO (14)		○		○ NC (14)
2	COM (15)	○			
1	NO (15)		○		○ NC (15)

Figure D-1. SCXI-1160 Front Connector Pin Assignment

Front Connector Signal Descriptions

Pin	Signal Name	Description
A1, A3, A5, A7, A9, A11, A13, A15, A17, A19, A21, A23, A25, A27, A29, A31	NO <15..0>	Normally Open Contact – These are the normally open contacts of the relays 15 through 0.
B2, B4, B6, B8, B10, B12, B14, B16, B18, B20, B22, B24, B26, B28, B30, B32	COM <15..0>	Common Contact – These are the common contacts of the relays 15 through 0.
C1, C3, C5, C7, C9, C11, C13, C15, C17, C19, C21, C23, C25, C27, C29, C31	NC <15..0>	Normally Closed Contact – These are the normally closed contacts of the relays 15 through 0.

Further information is given in Chapter 2, *Configuration and Installation*.

Appendix E

SCXI-1160 Cabling

This appendix describes how to use and install the hardware accessories for the SCXI-1160:

- SCXI-1340 cable assembly
- SCXI-1341 Lab-NB, Lab-PC, and Lab-PC+ cable assembly
- SCXI-1342 PC-LPM-16 cable assembly
- SCXI-1344 Lab-LC cable assembly
- SCXI-1348 DIO-32 cable assembly
- SCXI-1180 feedthrough panel
- SCXI-1302 50-pin terminal block
- SCXI-1351 one-slot cable extender
- SCXI-1343 screw terminal adapter

SCXI-1340 Cable Assembly

The SCXI-1340 cable assembly connects an MIO-16 or DIO-24 board to an SCXI-1160 module. It consists of a 50-conductor ribbon cable that has a 50-pin female connector at one end that connects to the I/O connector of the data acquisition board, and a mounting bracket at the other end. Attached to the mounting bracket is the 50-pin female mounting bracket connector that connects to the rear signal connector of the module. A male breakout connector is near the mounting bracket on the ribbon cable. You can use this male breakout connector to extend the signals of the MIO-16 or DIO-24 board to an SCXI-1180 feedthrough panel or an SCXI-1181 breadboard module. All 50 pins from the MIO-16 or DIO-24 board go straight to the rear signal connector. You can use a standard 50-pin ribbon cable in lieu of the SCXI-1340 cable assembly.

The SCXI-1340 has the following advantages over the ribbon cable:

- The SCXI-1340 produces strain relief so that you cannot accidentally disconnect the cable.
- The SCXI-1340 includes a mounting bracket that mounts to the chassis so that you can remove and reinsert the module without explicitly removing the cable from the back of the chassis. This is especially useful when the SCXI chassis is rack mounted, making rear access difficult.
- The SCXI-1340 has an extra male breakout connector for use with the SCXI-1180 feedthrough panel or additional modules or breadboards that need a direct connection to the MIO-16 or DIO-24 board.

- The SCXI-1340 rear panel gives the module and the chassis both mechanical and electrical shielding.

Table E-1 lists the pin equivalences of the MIO-16 and DIO-24 boards and the SCXI-1160.

Table E-1. SCXI-1160 and Board Pinout Equivalences

Pin	SCXI-1160 Rear Signal Connector	MIO-16 Board Equivalent	DIO-24 Board Equivalent
24	DIG GND (MIO)	DIG GND	
25	SERDATIN	ADIO0	PB3
26	SERDATOUT (MIO)	BDIO0	
27	DAQD*/A	ADIO1	PB2
29	SLOT0SEL*	ADIO2	PB1
31	SERCLK (DIO)		PB0
37	SERCLK (MIO)	EXTSTROBE*	
47	SERDATOUT (DIO)		PA0
50	DIG GND (DIO)		DIG GND

No other pins are connected on the SCXI-1160.

SCXI-1340 Installation

Follow these steps to install the SCXI-1340:

1. Make sure that the computer and the SCXI chassis are turned off.
2. Install the SCXI module in the chassis.
3. Plug the mounting bracket connector onto the module rear signal connector (see Figure E-1). An alignment tab on the bracket enters the upper board guide of the chassis.
4. Screw the mounting bracket to the threaded strips in the rear of the chassis.
5. Connect the loose end of the cable assembly to the MIO-16 or DIO-24 board rear signal connector.

Check the installation.

After step 1, the order of these steps is not critical; however, it is easier to locate the correct position for the mounting bracket with a module installed in the chassis. If you are attaching a cable to the breakout connector, installation is easiest if you attach the second cable before installing the SCXI-1340.

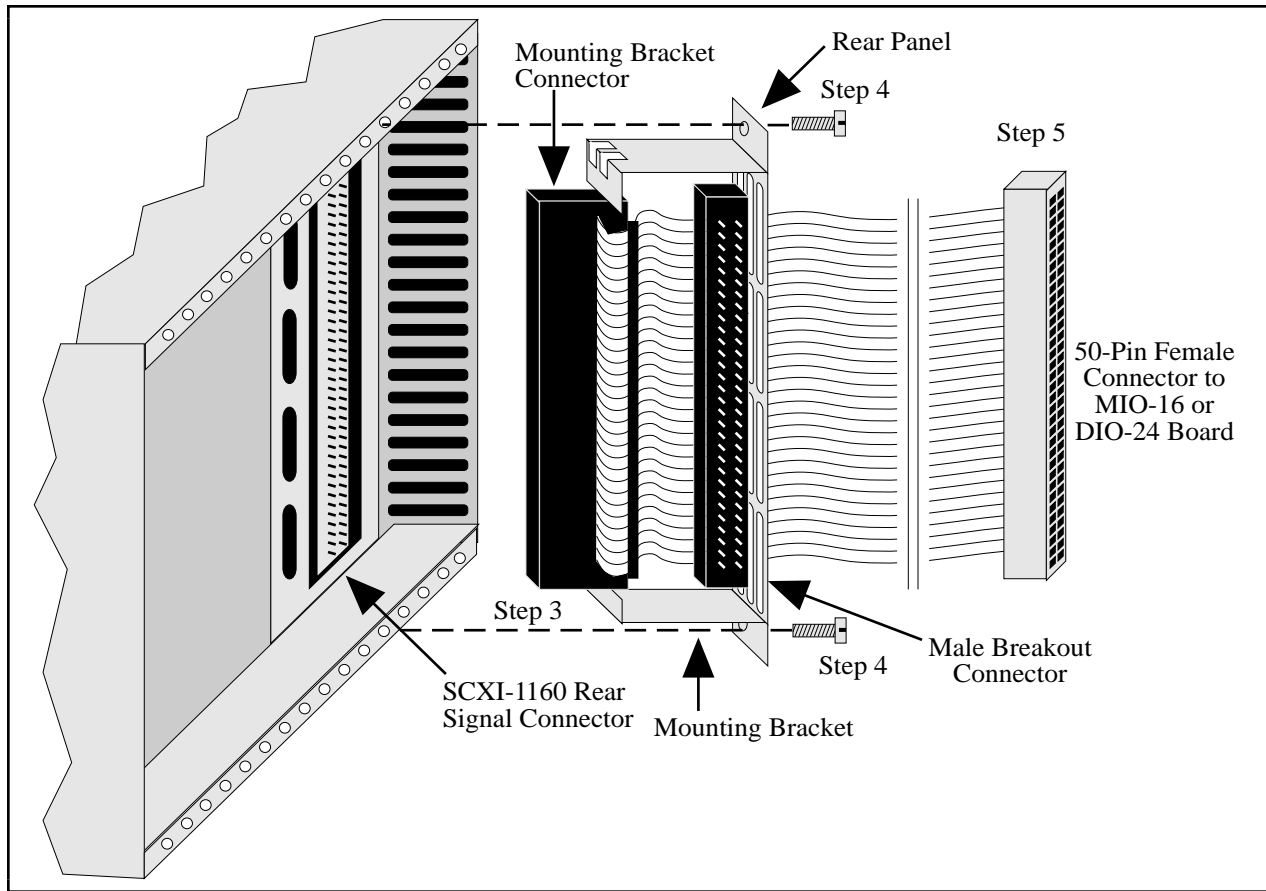

Figure E-1. SCXI-1340 Installation

SCXI-1341 Lab-NB, Lab-PC, or Lab-PC+ and SCXI-1344 Lab-LC Cable Assembly

The SCXI-1341 Lab-NB, Lab-PC, or Lab-PC+ cable assembly connects a Lab-NB, Lab-PC, or Lab-PC+ board to an SCXI-1160 module. The SCXI-1344 Lab-LC cable assembly connects a Lab-LC board to an SCXI-1160 module. The SCXI-1341 and SCXI-1344 cable assemblies consist of two pieces—a 50-conductor ribbon cable that connects the Lab board to the rear connector of the other piece, the adapter board. The adapter board converts the signals from the Lab board I/O connector to a format compatible with the SCXI-1160 rear signal connector pinout at the front connector of the SCXI-1341 or SCXI-1344. The adapter board also has an additional male breakout connector that provides the unmodified Lab board signals for use with an SCXI-1180 feedthrough panel or SCXI-1181 breadboard module. The adapter board gives the Lab boards full access to the digital control lines. The position of jumper W1 on the SCXI-1341 and SCXI-1344 is irrelevant because the SCXI-1160 does not use jumper W1. Table E-2 lists the SCXI-1341 and SCXI-1344 pin translations.

Table E-2. SCXI-1341 and 1344 Pin Translations

Lab Board Pin	Lab Board Signal	SCXI-1160 Pin	SCXI-1160 Signal
1	ACH0	3	No Connect
2	ACH1	5	No Connect
3	ACH2	7	No Connect
4	ACH3	9	No Connect
5	ACH4	11	No Connect
6	ACH5	13	No Connect
7	ACH6	15	No Connect
8	ACH7	17	No Connect
9	AIGND	1-2	No Connect
10	DAC0OUT	20	No Connect
11	AOGND	23	No Connect
12	DAC1OUT	21	No Connect
13, 50	DGND	24	DIG GND
26	PB4	25	SERDATIN
27	PB5	27	DAQD*/A
28	PB6	29	SLOT0SEL*
29	PB7	37	SERCLK
31	PC1	26	SERDATOUT
32	PC2	28	No Connect
40	EXTCONV*	36	No Connect
43	OUTB1	46	No Connect
49	+5 V	34-35	No Connect

All other pins of the Lab board pinout are not sent to the SCXI-1160 rear signal connector.

SCXI-1341 and SCXI-1344 Installation

Follow these steps to install the SCXI-1341 or SCXI-1344:

1. Make sure that the computer and the SCXI chassis are turned off.
2. Install the SCXI module in the chassis.
3. Connect one end of the ribbon cable to the adapter board rear connector. This is the 50-pin connector of the SCXI-1344 cable.
4. Plug the adapter board front connector to the module rear signal connector. A corner of the adapter board will enter the upper board guide of the chassis.
5. Screw the rear panel to the threaded strips in the rear of the chassis.
6. For an SCXI-1341, connect the loose end of the ribbon cable to the Lab-NB, Lab-PC, or Lab-PC+ I/O connector. For an SCXI-1344, connect the two 26-pin connectors to the Lab-LC board according to the instructions given in the *Installation* section of Chapter 2, *Configuration and Installation*, of the *Lab-LC User Manual*.

Check the installation.

SCXI-1342 PC-LPM-16 Adapter Board

The SCXI-1342 PC-LPM-16 cable assembly connects a PC-LPM-16 board to an SCXI-1160 module. The SCXI-1342 cable assembly consists of two pieces—a 50-conductor ribbon cable that connects the PC-LPM-16 board to the other piece, the adapter board. The adapter board converts the signals from the PC-LPM-16 I/O connector to a format compatible with the SCXI-1160 rear signal connector pinout. The adapter board also has an additional male breakout connector that provides the unmodified PC-LPM-16 signals for use with an SCXI-1180 feedthrough panel or SCXI-1181 breadboard module. The adapter board gives the PC-LPM-16 full access to the digital control lines. The position of jumper W1 on the SCXI-1342 is irrelevant because the SCXI-1160 does not use jumper W1. Table E-3 lists the SCXI-1342 pin translations.

Table E-3. SCXI-1342 Pin Translations

PC-LPM-16 Pin	PC-LPM-16 Signal	Rear Signal Connector Pin	SCXI-1160 Use
1-2	AIGND	1-2	No Connect
3	ACH0	3	No Connect
4	ACH8	4	No Connect
5	ACH1	5	No Connect
6	ACH9	6	No Connect
7	ACH2	7	No Connect
8	ACH10	8	No Connect
9	ACH3	9	No Connect
10	ACH11	10	No Connect
11	ACH4	11	No Connect
12	ACH12	12	No Connect
13	ACH5	13	No Connect
14	ACH13	14	No Connect
15	ACH6	15	No Connect
16	ACH14	16	No Connect
17	ACH7	17	No Connect
18	ACH15	18	No Connect
19, 50	DGND	24	DIG GND
28	DIN6	26	SERDATOUT
29	DIN7	28	No Connect
34	DOUT4	25	SERDATIN
35	DOUT5	27	DAQD*/A
36	DOUT6	29	SLOT0SEL*
37	DOUT7	37	SERCLK
46	OUT2	46	No Connect
49	+5 V	34-35	No Connect

All other pins of the PC-LPM-16 pinout are not sent to the SCXI-1160 rear signal connector.

SCXI-1342 Installation

Follow these steps to install the SCXI-1342:

1. Make sure that the computer and the SCXI chassis are turned off.
2. Install the SCXI module to which the SCXI-1342 will connect.
3. Connect one end of the ribbon cable to the adapter board rear connector.
4. Plug the adapter board front connector onto the module rear signal connector. A corner of the adapter board will enter the upper board guide of the chassis.
5. Screw the rear panel to the threaded strips in the rear of the chassis.
6. Connect the loose end of the ribbon cable to the PC-LPM-16 I/O connector.

DIO-96, AT-MIO-16D, and AT-MIO-64F-5 Board Connection

To use your SCXI-1160 with a DIO-96, AT-MIO-16D, or AT-MIO-64F-5 board, you need an NB5 cable. The NB5 cable is a ribbon cable with a 100-pin connector that mates with the data acquisition board rear signal connector. The other end of the cable is divided into two 50-pin connectors. Use positions 1 through 50 of the NB5 connector to control the SCXI-1160 and the SCXIbus via serial communication. Positions 51 through 100 of the NB5 cable are not used by the SCXI-1160 for serial communication. You may connect the 50-pin connector directly to the SCXI-1160 or you may use an SCXI-1351.

The SCXI-1351 has the following advantages over the ribbon cable:

- The SCXI-1351 produces strain relief so that you cannot accidentally disconnect the cable.
- The SCXI-1351 includes a mounting bracket that mounts to the chassis so that you can remove and reinsert the module without explicitly removing the cable from the back of the chassis. This is especially useful when the SCXI chassis is rack mounted, making rear access difficult.
- The SCXI-1351 has an extra female connector for use with the SCXI-1180 feedthrough panel or additional modules or breadboards that need a direct connection to the DIO-96 board.
- The SCXI-1351 rear panel gives the module and the chassis both mechanical and electrical shielding.

Table E-4 lists the pin equivalences of the DIO-96, AT-MIO-16D, and AT-MIO-64F-5 board and the SCXI-1162.

Table E-4. SCXI-1160, DIO-96, AT-MIO-16D, and AT-MIO-64F-5 Pinout Equivalences

Pin	SCXI-1160 Rear Signal Serial Connector	DIO-96 Board Equivalent	AT-MIO-16D	AT-MIO-64F-5
24	DIG GND (MIO)		DIG GND	DIG GND
25	SERDATIN	APB3	ADIO0	ADIO0
26	SERDATOUT (MIO)		BDIO0	BDIO0
27	DAQD*/A	APB2	ADIO1	ADIO1
29	SLOT0SEL*	APB1	ADIO2	ADIO2
31	SERCLK (DIO)	APB0		
37	SERCLK (MIO)		EXTSTROBE*	EXTSTROBE*
47	SERDATOUT (DIO)	APA0		
50	DIG GND (DIO)	DIG GND		

No other pins are connected on the SCXI-1160.

SCXI-1351 and NB5 Cable Installation

Follow these steps to install the SCXI-1351:

1. Make sure that the computer and the SCXI chassis are turned off.
2. Install the SCXI module in the chassis.
3. Connect the position 1 through 50 connector of the NB5 cable to the male breakout connector on the SCXI-1351.
4. Plug the mounting bracket connector onto the module rear signal connector (see Figure E-2). An alignment tab on the bracket will enter the upper board guide of the chassis.
5. Screw the mounting bracket to the threaded strips in the rear of the chassis.
6. Connect the 100-pin connector of the NB5 cable to the DIO-96 board.

After step 1, the order of these steps is not critical; however, it is easier to locate the correct position for the mounting bracket with a module installed in the chassis. If you are attaching a cable to the female connector, installation is easiest if you attach the second cable before installing the SCXI-1351.

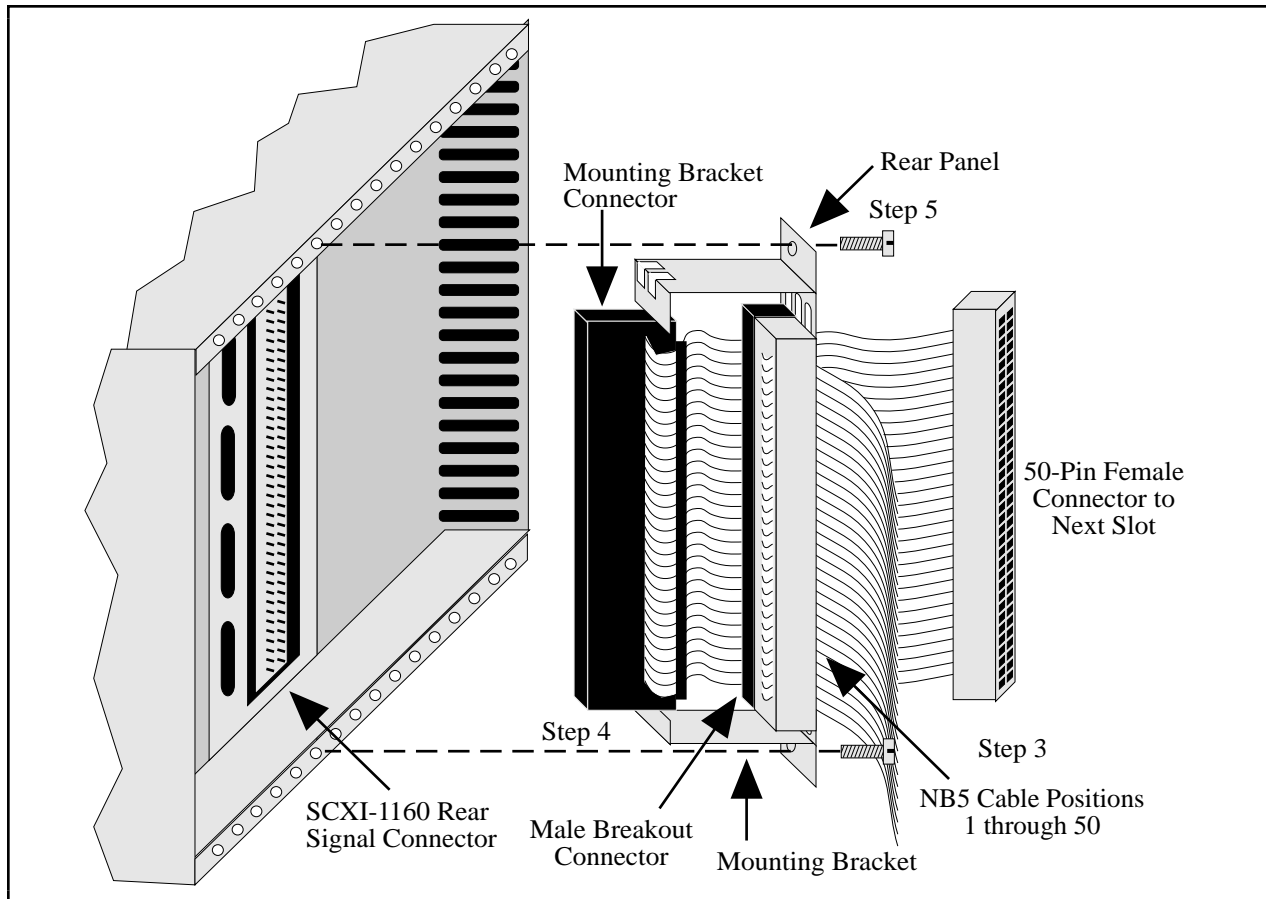

Figure E-2. SCXI-1351 and NB5 Cable Installation

SCXI-1348 DIO-32F Adapter Board

The SCXI-1348 DIO-32F cable assembly connects a DIO-32F board to an SCXI-1160 module. The SCXI-1348 cable assembly consists of two pieces—a 50-conductor shielded ribbon cable that connects the DIO-32F board to the other piece, the adapter board. The adapter board converts the signals from the DIO-32F I/O connector to a format compatible with the SCXI-1160 rear signal connector pinout. The adapter board also has an additional male breakout connector that provides the unmodified DIO-32F signals for use with an SCXI-1180 feedthrough panel or SCXI-1181 breadboard module. The adapter board gives the DIO-32F full access to the digital control lines. Table E-5 lists the SCXI-1348 pin translations.

Table E-5. SCXI-1348 Pin Translations

DIO-32F Pin	DIO-32F Signal	Rear Signal Connector Pin	SCXI-1160 Use
1	DIOD1	46	No Connect
2	DIOD4	40	No Connect
3	DIOD3	42	No Connect
4	DIOD0	48	No Connect
5	DIOD6	36	No Connect
6	DIOD7	34	No Connect
7	DIOD2	44	No Connect
8	DIOD5	38	No Connect
9	DIOC5	5	No Connect
10	DIOC7	1	No Connect
11	DIOC3	9	No Connect
12	DIOC1	13	No Connect
13	DIOC2	11	No Connect
14	DIOC0	15	No Connect
15	DIOC6	3	No Connect
16	DIOC4	7	No Connect
17, 19	DIG GND	2, 4	No Connect
21, 23	DIG GND	6, 8	No Connect
25, 26	DIG GND	10, 12	No Connect
28, 30	DIG GND	14, 16	No Connect
32, 34	DIG GND	50	DIG GND
18	ACK2	26	No Connect
20	IN2	28	No Connect
22	OUT2	30	No Connect
24	REQ2	32	No Connect
27	ACK1	18	No Connect
29	IN1	20	No Connect
31	OUT1	22	No Connect
33	REQ1	24	No Connect
35	DIOA4	39	No Connect
36	DIOA6	35	No Connect
37	DIOA0	47	SERDATOUT
38	DIOA2	43	No Connect
39	DIOA1	45	No Connect
40	DIOA3	41	No Connect
41	DIOA7	33	No Connect
42	DIOA5	37	No Connect
43	DIOB5	21	No Connect
44	DIOB2	27	DAQD*/A
45	DIOB7	17	No Connect
46	DIOB6	19	No Connect
47	DIOB0	31	SERCLK
48	DIOB3	25	SERDATIN
49	DIOB4	23	No Connect
50	DIOB1	29	SLOT0SEL*

SCXI-1348 Installation

Follow these steps to install the SCXI-1348:

1. Make sure that the computer and the SCXI chassis are turned off.
2. Install the SCXI module to which the SCXI-1348 will connect.
3. Connect one end of the ribbon cable to the adapter board rear connector.
4. Plug the adapter board front connector onto the module rear signal connector. A corner of the adapter board will enter the upper board guide of the chassis.
5. Screw the rear panel to the threaded strips in the rear of the chassis.
6. Connect the loose end of the ribbon cable to the DIO-32F I/O connector.

Check the installation.

SCXI-1180 Feedthrough Panel

The SCXI-1180 feedthrough panel provides front panel access to the signals of any data acquisition board that uses a 50-pin I/O connector. The SCXI-1180 consists of a front panel with a 50-pin male front panel connector that occupies one slot in the SCXI chassis, and a ribbon cable with a female rear connector and a male breakout connector. You can attach the rear connector to the male breakout connector of an SCXI-1340, SCXI-1341, SCXI-1342, SCXI-1344, or SCXI-1351 in the adjacent slot. The breakout connector further extends the cabling scheme. The front panel connector has the feedthrough connection. You can attach an SCXI-1302 terminal block to the front panel connector for simple screw terminal connections. A rear filler panel that shields and protects the interior of the SCXI chassis is also included.

SCXI-1180 Installation

Install the SCXI-1180 to the right of a slot that has an SCXI-1340, SCXI-1341, SCXI-1342, or SCXI-1344 cable assembly or an SCXI-1351 slot extender in its rear connector space.

Follow these steps to install the SCXI-1180:

1. Make sure that the computer and the SCXI chassis are turned off.
2. Remove the front filler panel of the slot where you want to insert the SCXI-1180.
3. Thread the rear connector through the front of the chassis to the rear of the chassis. Attach the rear connector to the breakout connector of the adjacent cable assembly or slot extender, as shown in Figure E-3.
4. Screw in the rear panel to the threaded strip in the rear of the chassis.
5. Screw the front panel into the front threaded strip, as shown in Figure E-4.

Check the installation.

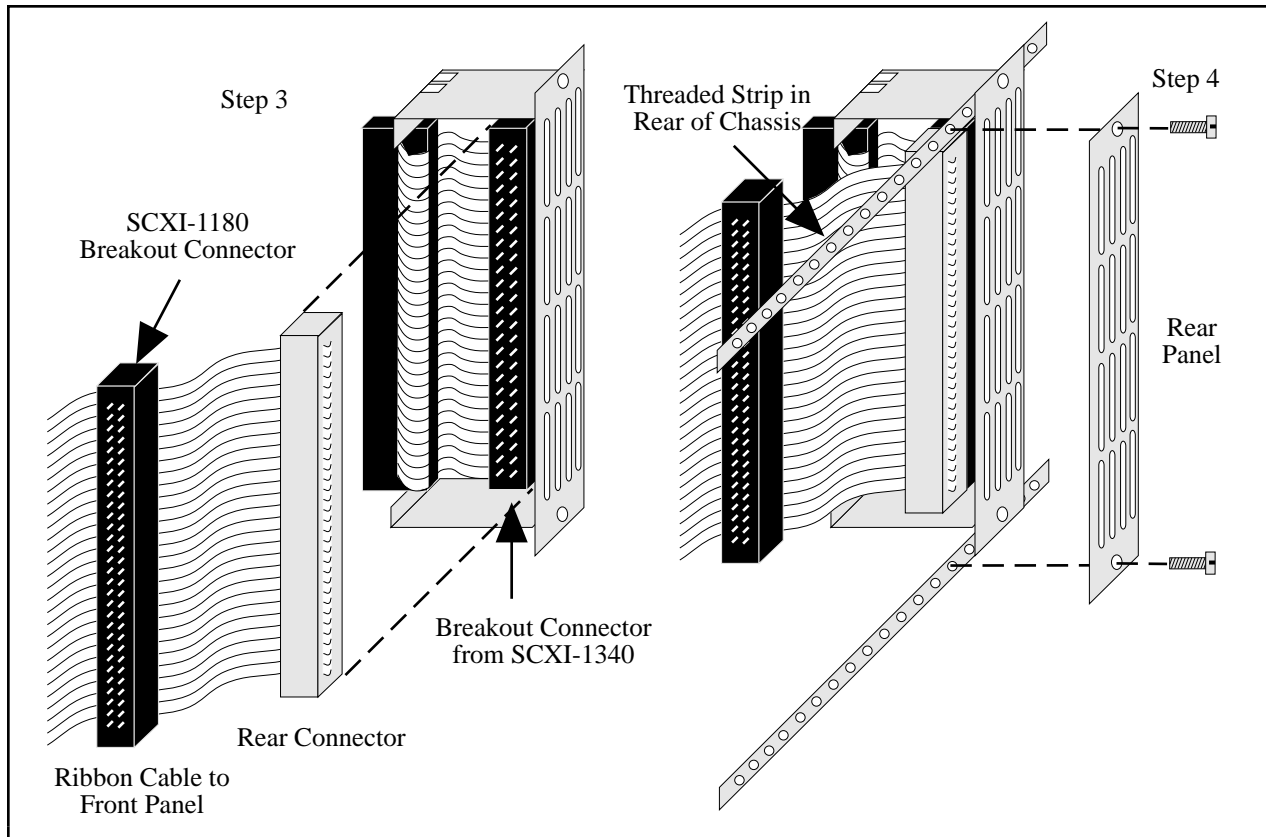

Figure E-3. SCXI-1180 Rear Connections

Note: If you are using the SCXI-1180 with an SCXI-1351 and an NB5 cable, connect the SCXI-1180 breakout connector to the female connector on the SCXI-1351. Place the SCXI-1180 to the *left* of the SCXI-1351 (looking to the front of the chassis).

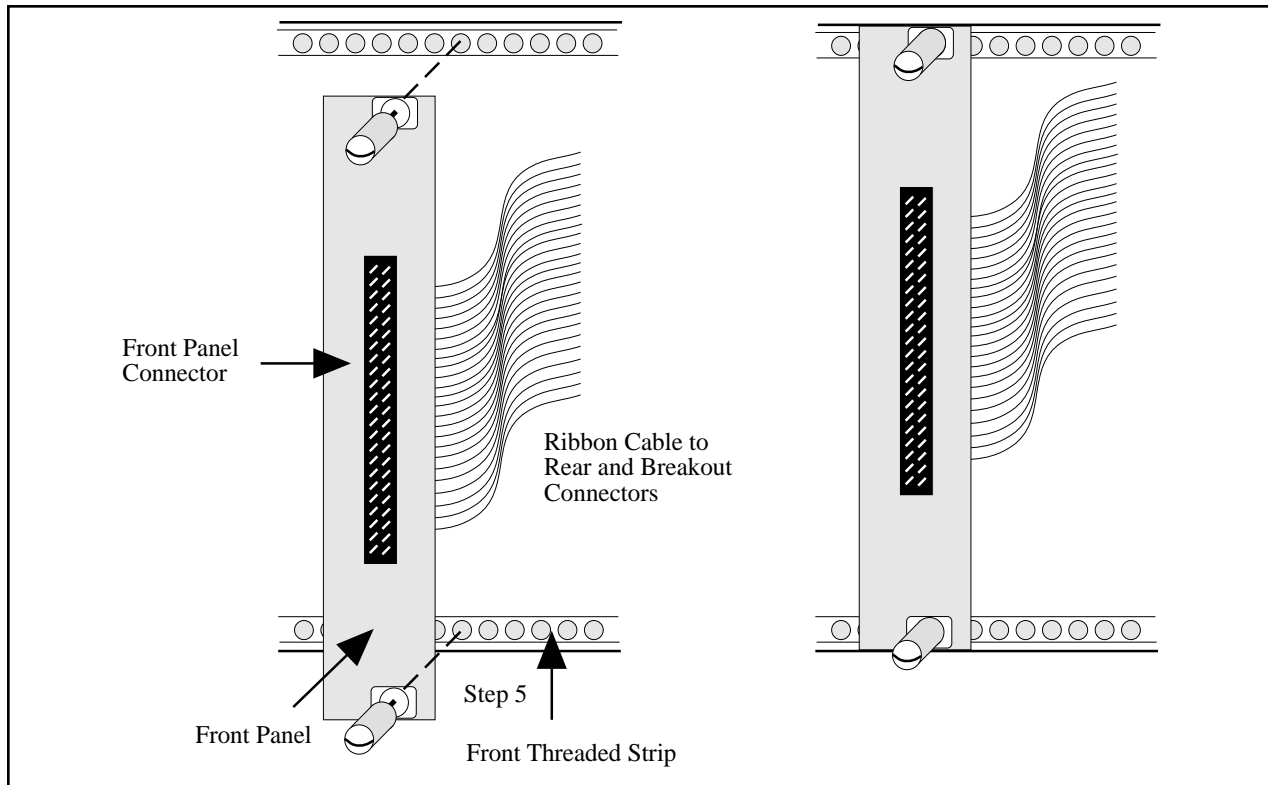

Figure E-4. SCXI-1180 Front Panel Installation

SCXI-1302 50-Pin Terminal Block

The SCXI-1302 terminal block has screw terminal connections for the 50-pin connector on the SCXI-1180 feedthrough panel.

SCXI-1302 Wiring Procedure

To wire the SCXI-1302 terminal block, you must remove the cover, connect all the wiring, and replace the cover. The procedure for this is as follows:

1. Unscrew the rear grounding screw on the back of the terminal block, as shown in Figure E-5.
2. With a flathead screwdriver, carefully pry the cover off the terminal block.
3. Insert each wire through the terminal block strain relief.
4. Connect the wires to the screw terminals.
5. Tighten the large strain relief screws to secure the wires.
6. Snap the cover back in place.
7. Reinsert the rear grounding screw. The terminal block is now ready to be connected to the front panel connector.

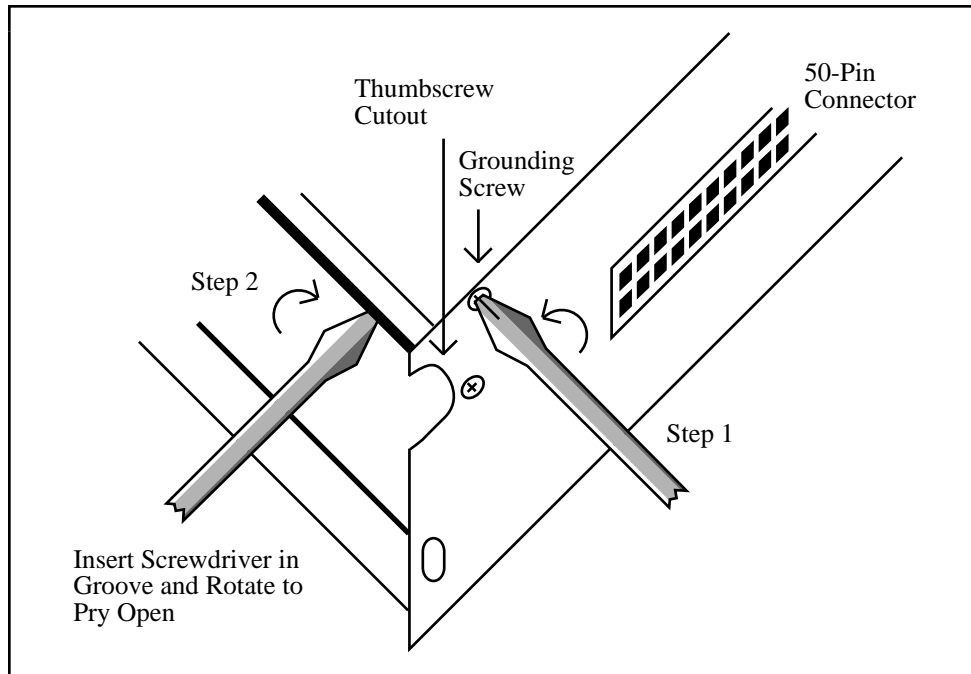

Figure E-5. SCXI-1350 Cover Removal

SCXI-1302 Installation

Follow these steps to install the SCXI-1302:

1. Install an SCXI-1180 feedthrough panel as described in the *SCXI-1180 Installation* section.
2. Wire the terminal block as previously described in the *SCXI-1302 Wiring Procedure* section.
3. Connect the SCXI-1302 terminal block to the front panel connector on the SCXI-1180 feedthrough panel. Be careful to fit the thumbscrews in the thumbscrew cutouts.
4. Tighten the top and bottom captive screws on the back of the terminal block into the screw holes in the front panel to hold the SCXI-1302 securely in place.

Check the installation.

SCXI-1351 One-Slot Cable Extender

The SCXI-1351 cable extender is a miniature SCXI-1340 cable assembly. Instead of connecting to an MIO board 1 m away, the SCXI-1351 female rear connector connects to a male breakout connector that must be in the rear connector space of the slot to the left. The SCXI-1351 has a female mounting bracket connector that mates with the rear signal connector of a module, and also has a male breakout connector on the ribbon cable for connecting to a feedthrough panel or more cable extenders.

SCXI-1351 Installation

Follow these steps to install the SCXI-1351:

1. Make sure that the computer and the SCXI chassis are turned off.
2. Install the SCXI module in the chassis.
3. Connect the rear connector of the cable extender to the breakout connector in the adjacent slot. This attachment is similar to Step 3 in the *SCXI-1180 Installation* section, as shown in Figure E-6.
4. Plug the mounting bracket connector to the module rear signal connector. An alignment tab on the bracket will enter the upper board guide of the chassis.
5. Screw the mounting bracket to the threaded strips in the rear of the chassis.

Check the installation.

Multiple-Chassis Connections for the SCXI-1160

The SCXI-1160 can operate in a multiple-chassis system with the DIO-24, DIO-96, MIO-16, and AT-MIO-64F-5 boards. A multiple-chassis system can consist of up to eight SCXI-1001 chassis controlled by the same data acquisition board. Notice that you cannot use the SCXI-1000 in a multiple-chassis system. For each chassis, you will need an SCXI-1350 multichassis adapter board and an NB1 ribbon cable.

SCXI-1350 Multichassis Adapter

Note: When connecting multiple chassis, you should use a 0.5 m length ribbon cable between chassis to minimize cable length and maintain signal integrity. However, you can use a 1.0 m cable from the data acquisition board to the first chassis. When you are using the AT-MIO-16D or AT-MIO-64F-5 or DIO-96 board, use an NB5 ribbon cable from the data acquisition board to the first chassis, connecting positions 1 through 50 to the SCXI-1350 in the first chassis.

SCXI-1350 Installation

After you have installed the data acquisition board into the computer and the SCXI modules into each of the SCXI-1001 chassis, cable one module from each chassis to the data acquisition board as follows:

1. Make sure that the computer and all the SCXI chassis are turned off.
2. Connect one end of the NB1 (or the 100-pin connector of the NB5) cable to the data acquisition board.
3. Plug the other end of the cable (or positions 1 through 50 of the NB5 cable) into the connector with the latches that are at the rear of the SCXI-1350 adapter board.

4. Connect another ribbon cable to the chassis extender connector that is in the middle of the SCXI-1350.
5. Plug the SCXI-1350 into the back of an SCXI module in the first chassis so that the module rear connector mates with the front connector on the SCXI-1350 adapter board. When you are connecting to an SCXI-1160, be sure to set the jumpers for either a DIO-type or an MIO-type board as needed.
6. Screw the rear panel to the threaded strips in the rear of the chassis.
7. Connect the loose end of the ribbon cable from step 4 into the rear connector of the second SCXI-1350, and install the adapter board.
8. Continue until all chassis are connected. You do not need to connect anything to the middle connector of the SCXI-1350 adapter board in the last chassis.

SCXI-1343 Rear Screw Terminal Adapter

You use the SCXI-1343 universal adapter to adapt custom wiring to the SCXI-1160. The SCXI-1343 has screw terminals and solder pads for signal connection. A strain relief is on the outside of the rear panel.

Table E-6 SCXI-1343 Pin Connections

Rear Signal Connector Pin	SCXI-1160 Use	Connection
1	No Connect	Solder pad
2	No Connect	Screw terminal
3	No Connect	Screw terminal
4	No Connect	Screw terminal
5	No Connect	Screw terminal
6	No Connect	Screw terminal
7	No Connect	Screw terminal
8	No Connect	Screw terminal
9	No Connect	Screw terminal
10	No Connect	Screw terminal
11	No Connect	Screw terminal
12	No Connect	Screw terminal
13	No Connect	Screw terminal
14	No Connect	Screw terminal
15	No Connect	Screw terminal
16	No Connect	Screw terminal
17	No Connect	Screw terminal

(continues)

Table E-6. SCXI-1343 Pin Connections (Continued)

Rear Signal Connector Pin	SCXI-1160 Use	Connection
18	No Connect	Screw terminal
19	No Connect	Screw terminal
20	No Connect	Solder pad
21	No Connect	Solder pad
22	No Connect	Solder pad
23	No Connect	Solder pad
24	DIG GND (MIO)	Solder pad
26	SERDATOUT (MIO)	Solder pad
27	DAQD*/A	Solder pad
28	No Connect	Solder pad
29	SLOT0SEL*	Solder pad
30	No Connect	Solder pad
31	SERCLK (DIO)	Solder pad
32	No Connect	Solder pad
33	No Connect	Solder pad
34-35	No Connect	Solder pad
36	No connect	Solder pad
37	SERCLK (MIO)	Solder pad
38	No Connect	Solder pad
39	No Connect	Solder pad
40	No Connect	Solder pad
41	No Connect	Solder pad
42	No Connect	Solder pad
43	No Connect	Solder pad
44	No Connect	Solder pad
45	No Connect	Solder pad
46	No Connect	Solder pad
47	SERDATOUT (DIO)	Solder pad
48	No Connect	Solder pad
49	No Connect	Solder pad
50	DIG GND (DIO)	Solder pad

SCXI-1343 Installation

1. Insert each wire through the adapter strain relief.
2. Make all solder connections first.
3. Tighten the strain relief screws to secure the wires.
4. Plug the adapter board front connector into the module rear signal connector. A corner of the adapter board will enter the upper board guide of the chassis.
5. Screw the rear panel to the threaded strips in the rear of the chassis.

Appendix F

Aromat Relay Technical Data*

This appendix contains technical data on Aromat Corporation relays. Aromat relays are used on the SCXI-1160.

* Copyright © Aromat Corporation, 1991. Reprinted with permission of copyright owner. All rights reserved. Aromat Corporation. 1991 *Relay Technical Data Book*.

Appendix G

Customer Communication

For your convenience, this appendix contains forms to help you gather the information necessary to help us solve technical problems you might have as well as a form you can use to comment on the product documentation. Filling out a copy of the *Technical Support Form* before contacting National Instruments helps us help you better and faster.

National Instruments provides comprehensive technical assistance around the world. In the U.S. and Canada, applications engineers are available Monday through Friday from 8:00 a.m. to 6:00 p.m. (central time). In other countries, contact the nearest branch office. You may fax questions to us at any time.

Corporate Headquarters

(512) 795-8248

Technical Support fax: (512) 794-5678

Branch Offices	Phone Number	Fax Number
Australia	03 879 9422	03 879 9179
Austria	0662 435986	0662 437010 19
Belgium	02 757 00 20	02 757 03 11
Denmark	45 76 26 00	45 76 71 11
Finland	90 527 2321	90 502 2930
France	1 48 65 33 00	1 48 65 19 07
Germany	089 7 14 50 93	089 7 14 60 35
Italy	02 48301892	02 48301915
Japan	03 3788 1921	03 3788 1923
Netherlands	01720 45761	01720 42140
Norway	03 846866	03 846860
Spain	91 640 0085	91 640 0533
Sweden	08 730 49 70	08 730 43 70
Switzerland	056 27 00 20	056 27 00 25
U.K.	0635 523545	0635 523154

or 0800 289877 (in U.K. only)

Technical Support Form

Photocopy this form and update it each time you make changes to your software or hardware, and use the completed copy of this form as a reference for your current configuration. Completing this form accurately before contacting National Instruments for technical support helps our applications engineers answer your questions more efficiently.

If you are using any National Instruments hardware or software products related to this problem, include the configuration forms from their user manuals. Include additional pages if necessary.

Name _____

Company _____

Address _____

Fax (____) _____ Phone (____) _____

Computer brand _____ Model _____ Processor _____

Operating system _____

Speed _____ MHz RAM _____ MB Display adapter _____

Mouse _____ yes _____ no Other adapters installed _____

Hard disk capacity _____ MB Brand _____

Instruments used _____

National Instruments hardware product model _____ Revision _____

Configuration _____

National Instruments software product _____ Version _____

Configuration _____

The problem is _____







List any error messages _____

The following steps will reproduce the problem _____

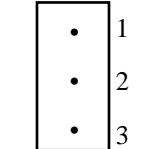
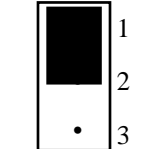
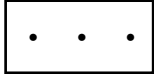
SCXI-1160 Hardware Configuration Form

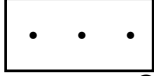
Record the settings and revisions of your hardware and software on the line to the right of each item. Complete a new copy of this form each time you revise your software or hardware configuration, and use this form as a reference for your current configuration. Completing this form accurately before contacting National Instruments for technical support helps our applications engineers answer your questions more efficiently.

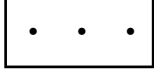
- SCXI-1160 Revision _____
- Chassis Slot _____
- Chassis Type _____

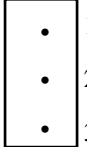
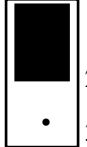
	My Setting	Factory Setting
• Jumper W1		
• Jumper W2		
• Jumper W3		
• Jumper W4		
• Jumper W5		

Note: Mark your jumper positions on the jumper diagrams in the left column.

- Other Modules and Chassis in System _____

- Data Acquisition Boards Installed _____

Documentation Comment Form

National Instruments encourages you to comment on the documentation supplied with our products. This information helps us provide quality products to meet your needs.

Title: **SCXI-1160 User Manual**

Edition Date: **March 1994**

Part Number: **320513-01**

Please comment on the completeness, clarity, and organization of the manual.

If you find errors in the manual, please record the page numbers and describe the errors.

Thank you for your help.

Name _____

Title _____

Company _____

Address _____

Phone (_____) _____

Mail to: Technical Publications
National Instruments Corporation
6504 Bridge Point Parkway, MS 53-02
Austin, TX 78730-5039

Fax to: Technical Publications
National Instruments Corporation
MS 53-02
(512) 794-5678

Glossary

Prefix	Meaning	Value
p-	pico-	10^{-12}
n-	nano-	10^{-9}
μ -	micro-	10^{-6}
m-	milli-	10^{-3}
k-	kilo-	10^3
M-	mega-	10^6

°	degrees
%	percent
Ω	ohms
e	strain
A	amperes
ACH#	data acquisition board analog input channel number
A/D	analog-to-digital
Arms	amperes, root mean square
AWG	American Wire Gauge
C	Celsius
CH#+	module positive input channel number
CH#-	module negative input channel number
cpm	counts per minute
cps	counts per second
COM	common
D/A	digital-to-analog
dB	decibels
DIN	Deutsche Industrie Norme
emf	electromotive force
FIFO	first-in-first-out
in.	inches
hex	hexadecimal
HSCR	Hardscan Control Register
Hz	hertz
ID	identification
I_i	input current leakage
I_{in}	input current
I/O	input/output
I_{out}	output current
LSB	least significant bit
m	meters

Glossary

M	megabytes of memory
MCH#+	module positive output channel number
MCH#-	module negative output channel number
MSB	most significant bit
MTS	multiplexed temperature sensor
NC	normally closed
NO	normally open
RAM	random-access memory
rms	root mean square
RTSI	Real-Time System Integration
SCXI	Signal Conditioning eXtensions for Instrumentation (bus)
SDK	Software Developer's Kit
sec	seconds
SPDT	single-pole double throw
SPI	serial peripheral interface
UL	Underwriters' Laboratory
V	volts
VI	virtual instrument
V _{IH}	volts input high
V _{IL}	volts input low
V _{in}	volts in
V _{OH}	volts output high
V _{OL}	volts output low
V _{out}	volts out
VAC	volts alternating current
VDC	volts direct current
V _{rms}	volts, root mean square
W	watts

Index

Numbers/Symbols

+5 V signal, 3-4, C-3

A

Address Handler, 4-1 to 4-2
 definition, 3-6
 purpose and use, 4-1 to 4-2
 register addresses, 4-1 to 4-2
 timing diagram, 2-22
 writing to Address Handler, 2-21 to 2-22
analog backplane protection, 3-8
arc suppression. *See* contact protection.
Aromat relays
 contacts, F-2 to F-6
 electronic circuit drive, F-6

B

backplane protection, 3-8

C

cabling
 custom cables, optional, 1-3 to 1-4
 DIO-96 board connection
 SCXI-1160 and DIO-96 board pinout equivalences, E-7
 SCXI-1351 and NB5 cable assembly and installation, E-6 to E-8
 SCXI-1180 feedthrough panel
 cable assembly, E-10
 installation, E-10 to E-12
 SCXI-1302 50-pin terminal block
 installation, E-13
 wiring procedure, E-12
 SCXI-1340
 cable assembly, E-1 to E-2
 installation, E-2 to E-3
 SCXI-1160 and board pinout equivalences, E-2
 SCXI-1341 Lab-NB, Lab-PC, or Lab-PC+
 cable assembly, E-3
 installation, E-4
 pin translations, E-4

- SCXI-1342 PC-LPM-16 adapter board
 - cable assembly, E-5
 - installation, E-6
 - pin translations, E-5
- SCXI-1343 rear screw terminal adapter
 - installation, E-16
 - pin connections, E-15 to E-16
- SCXI-1344 Lab-LC
 - cable assembly, E-3
 - installation, E-4
 - pin translations, E-4
- SCXI-1348 DIO-32F adapter board
 - cable assembly, E-8
 - installation, E-10
 - pin translations, E-9
- SCXI-1351 one-slot cable extender
 - cable assembly, E-13
 - installation, E-14
- CH <4..0> bit, Slot-Select Register, 4-8
- CHSGND signal, SCXIbus connector, 3-4, C-3
- COM connection, relay channels, 3-7
- COM<15..0> signal, front connector, 2-10, D-2
- communication signals, 2-19 to 2-25
 - Address Handler timing diagram, 2-22
 - communicating on SPI bus, 2-19
 - Data Register write timing diagram, 2-23
 - Module ID Register timing diagram, 2-24
 - reading from Module ID Register, 2-23 to 2-24
 - reading from Status Register, 2-24 to 2-25
 - serial data timing diagram, 2-21
 - slot-select timing diagram, 2-20
 - Status Register timing diagram, 2-24 to 2-25
 - writing the slot-select number, 2-20 to 2-21
 - writing to Address Handler, 2-21 to 2-22
 - writing to Data Register, 2-22 to 2-23
- configuration. *See* jumper configuration; signal connections.
- contact protection
 - Aromat relays, F-2 to F-6
 - inductive load connections, 2-10 to 2-12
 - arc suppressor pad locations, 2-12
 - COM to NC arc suppressor placement, 2-12
 - COM to NO arc suppressor placement, 2-11
 - using flyback diode, 2-11
- contact rating specifications, A-1
- custom cables, optional, 1-3 to 1-4
- customer communication, *xiii*, G-1

D

- D*/A signal
 - SCXIbus connector, 3-4, C-3
 - writing to Data Register, 3-7

- DAQD*/A signal
 - digital I/O signal connections, 2-18
 - reading from Module ID Register, 2-23 to 2-24
 - reading from Status Register, 2-24 to 2-25
 - rear signal connector, 2-17, B-2
 - writing the slot-select number, 2-20 to 2-21
 - writing to Address Handler, 2-21 to 2-22
 - writing to Data Register, 2-22 to 2-23, 5-2 to 5-3
- Data Register, 4-4
 - control of relay channels, 3-7 to 3-8, 5-1
 - definition, 3-6
 - description, 4-4
 - register writes, 5-1 to 5-2
 - truth table for resetting and setting relays, 4-4
 - write timing diagram, 2-23
 - writing to Data Register, 2-22 to 2-23, 3-7
- DIGGND signal, rear signal connector, 2-17, B-2
- digital control circuitry
 - diagram, 3-6 to 3-7
 - theory of operation, 3-6 to 3-7
- digital I/O signal connections
 - pin equivalences, 2-19
 - rear signal connector, 2-17 to 2-19
 - specifications and ratings, 2-19
- digital interface circuitry
 - block diagram, 3-5
 - theory of operation, 3-5 to 3-6
- DIO-32F adapter board. *See* SCXI-1348 DIO-32F adapter board.
- DIO-96 board connection
 - SCXI-1160 and DIO-96 board pinout equivalences, E-7
 - SCXI-1351 and NB5 cable assembly and installation, E-6
- documentation
 - conventions used in manual, *xii*
 - organization of manual, *xi-xii*
 - related documentation, *xiii*

E

- electrical hazard warning. *See* hazardous voltage warnings.
- equipment, optional, 1-3 to 1-4
- EXTSTROBE* register, 5-2 to 5-3

F

- fax technical support, G-1
- front connector, 2-9 to 2-12
 - contact protection, 2-10 to 2-12
 - arc suppressor pad locations, 2-12
 - COM to NC arc suppressor placement, 2-12
 - COM to NO arc suppressor placement, 2-11
 - using flyback diode, 2-11

- pin assignments, 2-9, D-1
- signal descriptions, 2-10, D-2

G

- gold plating on relay, 2-8

H

- hazardous voltage warnings
 - SCXI-1160 module, 2-4
 - SCXI-1324 terminal block, 2-13

I

- inductive load connections. *See* contact protection.
- initialization of SCXI-1160 module, 5-3
- installation
 - hardware installation, 2-7 to 2-8
 - SCXI-1180 feedthrough panel, E-10 to E-12
 - SCXI-1302 50-pin terminal block, E-13
 - SCXI-1324 terminal block, 2-15
 - SCXI-1340, E-2 to E-3
 - SCXI-1341 Lab-NB, Lab-PC, or Lab-PC+, E-4
 - SCXI-1342 PC-LPM-16 adapter board, E-6
 - SCXI-1343 rear screw terminal adapter, E-15
 - SCXI-1344 Lab-LC, E-4
 - SCXI-1348 DIO-32F adapter board, E-10
 - SCXI-1351 and NB5, E-7 to E-8
 - SCXI-1351 one-slot cable extender, E-13
 - unpacking the SCXI-1160 module, 1-4
- INTR* signal, SCXIbus connector, 3-4, C-3

J

- jumper configuration
 - digital signal connections and jumper settings, 2-6 to 2-7
 - overview, 2-5
 - parts locator diagram
 - detailed, 2-3
 - general, 2-2
 - W1 and W5, 2-5 to 2-6
 - W2, W3, and W4, 2-7

L

Lab-LC. *See* SCXI-1344 Lab-LC.

Lab-NB, Lab-PC, or Lab-PC+. *See* SCXI-1341 Lab-NB, Lab-PC, or Lab-PC+.

LabVIEW software, 1-2, 1-3

LabWindows software, 1-2, 1-3

M

manual. *See* documentation.

MISO signal

digital signal connections, 2-6

jumper connection, 2-5

SCXIBus connector, 3-4, C-3

Module ID Register, 4-3

definition, 3-7

description, 4-3

jumper connections, 2-5, 2-6

reading from Module ID Register, 2-23 to 2-24

timing diagram, 2-24

MOSI signal

SCXIBus connector, 3-4, C-3

Slot-Select Register, 4-8

writing to Data Register, 3-7

N

NB5. *See* SCXI-1351 and NB5.

NC connection, relay channels, 3-7

NC<15..0> bit, Data Register, 4-4

NC<15..0> signal, front connector, 2-10, D-2

NI-DAQ software, 1-2, 1-3

NO connection, relay channels, 3-7

NO<15..0> bit, Data Register, 4-4

NO<15..0> signal, front connector, 2-10, D-2

O

operating environment specifications, A-2

operation of SCXI-1160. *See* theory of operation.

P

Parking Register, 4-5

parts locator diagram

detailed, 2-3

general, 2-2

- SCXI-1324 terminal block, 2-14
- PC-LPM-16 adapter board. *See* SCXI-1342 PC-LPM-16 adapter board.
- physical specifications, A-2
- pin assignments
 - front connector, 2-9, D-1
 - rear signal connector, 2-16, B-1
 - SCXI-1343 rear screw terminal adapter, E-15 to E-16
 - SCXIBus connector, 3-3, C-2
- pin equivalences
 - rear signal connector to data acquisition boards, 2-19
 - SCXI-1160 and board pinout equivalences, E-2
 - SCXI-1160 and DIO-96 board pinout equivalences, E-7
 - SCXIBus connector to rear signal connector, 3-5
 - SCXIBus to SCXI-1160 rear signal connector to data acquisition board, 5-2
- pin translations
 - SCXI-1341 Lab-NB, Lab-PC, or Lab-PC+, E-4
 - SCXI-1342 PC-LPM-16 adapter board, E-5
 - SCXI-1344 Lab-LC, E-4
 - SCXI-1348 DIO-32F adapter board, E-9
- programming
 - examples, 5-3 to 5-5
 - initialization, 5-3
 - notation, 5-1
 - register selection and write procedure, 5-2 to 5-3
 - register writes, 5-1 to 5-2
 - SCXIBus to SCXI-1160 rear signal connector to data acquisition board pin equivalents, 5-2

R

- rear signal connector, 2-15 to 2-19
 - digital I/O signal connections, 2-17 to 2-19
 - overview, 2-15
 - pin assignments, 2-16, B-1
 - pin equivalences
 - data acquisition board, 2-19
 - SCXIBus connector, 3-5
 - signal descriptions, 2-17, B-2
 - timing requirements and communication protocol, 2-19 to 2-25
- registers
 - Address Handler, 4-1 to 4-2
 - definition, 3-6
 - register addresses, 4-1 to 4-2
 - timing diagram, 2-22
 - writing to Address Handler, 2-21 to 2-22
 - Data Register
 - control of relay channels, 3-7 to 3-8, 4-4, 5-1
 - definition, 3-6
 - description, 4-4
 - register writes, 5-1 to 5-3
 - write timing diagram, 2-23
 - writing to Data Register, 2-22 to 2-23, 3-7
 - description format, 4-1

- Module ID Register
 - definition, 3-7
 - description, 4-3
 - jumper connections, 2-5, 2-6
 - reading from Module ID Register, 2-23 to 2-24
 - timing diagram, 2-24
- Parking Register, 4-5
- programming
 - examples, 5-3 to 5-5
 - initialization, 5-3
 - notation, 5-1
 - register selection and write procedure, 5-2 to 5-3
 - register writes, 5-1 to 5-2
 - SCXibus to SCXI-1160 rear signal connector equivalents, 5-2
- SCXI-1160 registers, 4-1
- Slot-Select Register, 4-7 to 4-8
- Status Register
 - definition, 3-7
 - description, 4-5
 - jumper connections, 2-5, 2-6
 - reading from Status Register, 2-24 to 2-25
 - timing diagram, 2-24 to 2-25
- relays, 3-7 to 3-8. *See also* contact protection.
 - Aromat relays
 - contacts, F-2 to F-6
 - electronic circuit drive, F-6
 - contact rating specifications, A-1
 - controlling with Data Register, 3-7 to 3-8, 4-4, 5-1
 - gold plating on relay, 2-8
 - programming example, 5-4
 - theory of operation, 3-7 to 3-8
 - truth table for resetting and setting relays, 4-4
- RESET* signal, 3-4, C-3

S

- SCXI-1160 module. *See also* installation; jumper configuration.
 - block diagram, 3-1
 - illustration, 1-1
 - kit contents, 1-2
 - optional equipment, 1-3 to 1-4
 - optional software, 1-2 to 1-3
 - overview, 1-1
 - unpacking, 1-4
- SCXI-1180 feedthrough panel
 - cable assembly, E-10
 - front panel installation, E-12
 - installation, E-10 to E-12
 - rear connections, E-11
- SCXI-1302 50-pin terminal block
 - cover removal, E-13
 - installation, E-13

- wiring procedure, E-12
- SCXI-1324 terminal block, 2-12 to 2-15
 - hazardous voltage warnings, 2-13
 - installation, 2-15
 - overview, 2-12 to 2-13
 - parts locator diagram, 2-14
 - signal connection procedure, 2-13
- SCXI-1340
 - cable assembly, E-1 to E-2
 - installation, E-2 to E-3
 - SCXI-1160 and board pinout equivalences, E-2
- SCXI-1341 Lab-NB, Lab-PC, or Lab-PC+
 - cable assembly, E-3
 - installation, E-4
 - pin translations, E-4
- SCXI-1342 PC-LPM-16 adapter board
 - cable assembly, E-5
 - installation, E-6
 - pin translations, E-5
- SCXI-1343 rear screw terminal adapter
 - installation, E-16
 - pin connections, E-15 to E-16
- SCXI-1344 Lab-LC
 - cable assembly, E-3
 - installation, E-4
 - pin translations, E-4
- SCXI-1348 DIO-32F adapter board
 - cable assembly, E-8
 - installation, E-10
 - pin translations, E-9
- SCXI-1351 and NB5
 - cable assembly, E-6
 - installation, E-7 to E-8
 - SCXI-1160 and DIO-96 board pinout equivalences, E-7
- SCXI-1351 one-slot cable extender
 - cable assembly, E-13
 - installation, E-14
- SCXibus connector
 - pin assignments, 3-3, C-2
 - signal descriptions, 3-4 to 3-5, C-3
- SERCLK signal
 - digital I/O signal connections, 2-18
 - reading from Module ID Register, 2-23 to 2-24
 - reading from Status Register, 2-24 to 2-25
 - rear signal connector, 2-17, B-2
 - writing the slot-select number, 2-20 to 2-21
 - writing to Address Handler, 2-21 to 2-22
 - writing to Data Register, 2-22 to 2-23, 5-2 to 5-3
- SERDATIN signal
 - digital I/O signal connections, 2-18
 - reading from Module ID Register, 2-23 to 2-24
 - reading from Status Register, 2-24 to 2-25
 - rear signal connector, 2-17, B-2
 - writing the slot-select number, 2-20 to 2-21

- writing to Address Handler, 2-21 to 2-22
- writing to Data Register, 2-22 to 2-23, 5-2 to 5-3
- SERDATOUT signal
 - digital I/O signal connections, 2-18
 - digital signal connections, 2-6
 - jumper connection, 2-5
 - rear signal connector, 2-17, B-2
- serial data timing diagram, 2-21
- Serial Peripheral Interface (SPI) bus communications. *See* communication signals.
- signal connections, 2-8 to 2-25
 - exceeding maximum ratings (warning), 2-8
 - front connector, 2-9 to 2-12
 - arc suppressor pad locations, 2-12
 - COM to NC arc suppressor placement, 2-12
 - COM to NO arc suppressor placement, 2-11
 - contact protection for inductive load connections, 2-10 to 2-12
 - contact protection using flyback diode, 2-11
 - pin assignments, 2-9
 - signal descriptions, 2-10
 - gold plating on relay, 2-8
 - rear signal connector, 2-15 to 2-19
 - data acquisition board pin equivalences, 2-19
 - digital I/O signal connections, 2-17 to 2-19
 - overview, 2-15
 - pin assignments, 2-16, B-1
 - signal descriptions, 2-17, B-2
 - timing requirements and communication protocol, 2-19 to 2-25
- SCXI-1324 terminal block, 2-12 to 2-15
 - hazardous voltage warnings, 2-13
 - installation, 2-15
 - overview, 2-12 to 2-13
 - parts locator diagram, 2-14
 - signal connection procedure, 2-13
- SCXibus connector, 3-4 to 3-5
- SL <3..0> bit, Slot-Select Register, 4-8
- Slot 0 registers, 4-7
- Slot-Select Register, 4-7 to 4-8
- slot selection
 - slot-select timing diagram, 2-20
 - writing the slot-select number, 2-20 to 2-21
- SLOT0SEL* signal
 - digital I/O signal connections, 2-18
 - reading from Module ID Register, 2-23 to 2-24
 - reading from Status Register, 2-24 to 2-25
 - rear signal connector, 2-17, B-2
 - Slot-Select Register, 4-8
 - writing the slot-select number, 2-20 to 2-21
 - writing to Address Handler, 2-21 to 2-22
 - writing to Data Register, 2-22 to 2-23, 5-2 to 5-3
- software, optional, 1-2 to 1-3
- specifications
 - contact ratings, A-1
 - digital I/O signal connections, 2-19
 - operating environment, A-2

- physical, A-2
- storage environment, A-2
- SPI bus. *See* communication signals.
- SPICLK signal
 - SCXIBus connector, 3-4, C-3
 - writing to Data Register, 3-7
- SS* signal
 - reading from Module ID Register, 2-23 to 2-24
 - reading from Status Register, 2-24 to 2-25
 - SCXIBus connector, 3-4, C-3
 - writing to Address Handler, 2-21 to 2-22
 - writing to Data Register, 2-22 to 2-23, 3-7
- Status Register, 4-5
 - definition, 3-7
 - description, 4-5
 - jumper connections, 2-5, 2-6
 - reading from Status Register, 2-24 to 2-25
 - timing diagram, 2-24 to 2-25
- storage environment specifications, A-2

T

- technical support, G-1
- terminal block. *See* SCXI-1302 50-pin terminal block; SCXI-1324 terminal block.
- theory of operation
 - block diagram, 3-1
 - digital control circuitry, 3-6 to 3-7
 - digital interface, 3-5 to 3-6
 - functional overview, 3-1 to 3-2
 - relay channels, 3-7 to 3-8
 - SCXIBus connector
 - equivalents for rear signal connector, 3-5
 - pin assignments, 3-3
 - signal descriptions, 3-4 to 3-5
- timing requirements and communication protocol. *See* communication signals.

U

- unpacking the SCXI-1160 module, 1-4

V

- V- signal, 3-4, C-3
- V+ signal, 3-4, C-3
- +5 V signal, 3-4
- voltage, hazardous. *See* hazardous voltage warnings.