

International Collaboration and Improvement of Mechatronics Education based on Simulation and Virtual Instrument

*Seong Joo Choi¹, Devdas Shetty², Jury Poduraev³, Woo Young Lee⁴,
Jae Hyup Lee⁵*

Abstract ^{3/4} *The mechatronics course, which is one of the important courses amongst modern engineering experimentation area, must not only cover experimental techniques, sensors and transducers, signal processing and data analysis, but also include fundamental concepts of computer based data acquisition and simulation. The course materials and experimental apparatus for virtual instrument based experiments and practices have been developed in the School of Mechanical Engineering in Korea University of Technology and Education(KUT) and College of Engineering at the University of Hartford. Computer based data acquisition is taught as a series of incremental steps that leads the student from being a novice to be capable of designing, instrumentation and executing their own computer based data acquisition experiment. Virtual Instrument based on PC with DAQ board and LabVIEW software play a central role in this course. The academic partnership of KUT, University of Hartford and Moscow State Technological University “STANKIN” has resulted in several experiments that illustrate how virtual instruments have been used to teach Mechatronics System Design.*

Index Terms ^{3/4} *virtual instrument, mechatronics system design, data acquisition, and sensor*

1 Seong Joo Choi, School of Mechanical Engineering, Korea University of Technology and Education, sjchoi@kut.ac.kr

2 Devdas Shetty, College of Engineering, University of Hartford, shetty@mail.hartford.edu

3 Jury Poduraev, Department of Robotics and Mechatronics, Moscow State Technological University “STANKIN”, poduraev@stankin.ru

4 Woo Young Lee, School of Mechanical Engineering, Korea University of Technology and Education, wylee@kut.ac.kr

5 Jae Hyup Lee, School of Information Technology, Korea University of Technology and Education jae@kut.ac.kr

Introduction

Mechatronics is a design philosophy, an integrating approach to engineering design. The primary factor in mechatronics is the involvement of these areas throughout the design process. Through a mechanism of simulating interdisciplinary ideas and techniques, mechatronics provides ideal conditions to raise the synergy, thereby providing catalytic effect for the new solutions to technically complex situations. An important characteristic of mechatronic system is their built-in intelligence that results through a combination of precision mechanical and electrical engineering and real time programming integrated to the design process.[1] The rapid change in this field of technology poses special problems for academic institutions. There is a continual need to update and augment the content of lecture courses to keep pace with this change, but it is in the area of engineering education and experimental work where major concerns arise. The central problem still remain the same; providing for students meaningful and relevant practical experiences while being limited by very finite resources in the provision of laboratory hardware and infrastructure. One solution to this problem is to use computer based techniques to interface the students with the physical world, with suitable front-end design to provide sophistication and increased flexibility.

Many academic courses regarding mechatronics have already begun incorporating computer-based educational tools for students use, either in the lectures or in the laboratory practices or both. Due to recent technological advances in computer technology and software, it is now feasible to implement more advanced, more efficient, highly interactive and very user-friendly systems without using expensive custom-written software and tools. In the laboratory applications, from the technical point of view, all the engineering problems deal with some physical quantities such as temperature, speed, position, current, voltage, pressure, force, torque, etc. A computer equipped with the suitable interface circuits, data acquisition systems and software, can give a visual look to these quantities, and can process the acquired data. [2]

In this paper, a model of teaching and learning experiences are presented to illustrate how virtual instrument have been used to teach engineering experimentation for mechatronics education.

Features of the Mechatronics Laboratory

Careful sequencing of lecture topics and laboratory experiments and practices are needed to ensure that the students are prepared for the laboratory activities and these activities augment the class lectures. Like most laboratory based courses, the course topics and experiments are a linked

progression that build on previous material. This same form of developmental instruction has been adopted as the framework for teaching data acquisition fundamentals in the course. Data acquisition is viewed as the means to accomplish the ends, and as such, data acquisition is treated as a tool to complement instruction in experimental method techniques. Throughout this development of data acquisition skills, virtual instruments are the conduit for conducting the experiments and serve as familiar interface in the weekly laboratory. Data acquisition techniques, including both hardware and software components, increase in their degree of sophistication.

At the front end of the mechatronic development process, students begin the course with the conception that a computer is primarily a tool to analyze experimental data that was manually collected and keyed into the computer. At the other end of the developmental process, students become comfortable using computer, including data acquisition hardware and software, as a composite tool for collecting, processing, analyzing and documenting experimental data. Over a series of steps, they learn that data acquisition is much more than simply connecting wire to a computer to collect voltages. They learn that signals can be enhanced using analog and/or digital techniques, convert to represent other physical parameters, analyzed, displayed, and stored. If needed, signals can even be exported from the computer to power transducers or actuators. This progression of data acquisition skill is dependent on virtual instrumentation. The students start off with a simple virtual instrument to collect data with data acquisition board. They progress to the point where they can select the data acquisition hardware needed for specific transducers, determine the required digital signal processing to enhance the signal, and, in some case, create their own virtual instruments. As various transducers are introduced in the laboratory, each of them with their-own operating requirements and output specifications, the instructor-written virtual instrument act as a common interface to collect data from each transducer. In the same fashion that a specific physical parameter can be best measured with a s special transducer, the students understand that there are optimum hardware components and software routine to collect and process data from each sensor.

The sequential exposure to more sophisticated data acquisition topics throughout the course is complemented with exposure to the hardware associated with data acquisition as well as the graphical programming skills to construct suitable virtual instruments. Table 1 illustrates the laboratory topics and the accompanying virtual instruments used in laboratory practice.

Figure 1 shows the front panel and block diagram of stepping motor simulator.

Number	Laboratory topics	Virtual Instruments
1	LabVIEW fundamentals	Hall effect sensor simulator
2	LabVIEW structures	D/A Converter, Binary counter
3	Serial port	Stepping Motor Simulator
4	Clusters, Local variables	Digital Clock
5	Temperature sensing	Data Logger, Temperature Monitor
6	Pressure sensor	Barometer
7	Strain gauge	Weight Measurement
8	Digital electronics	Gate, Counter
9	Analog electronics	Op-Amp Circuit
10	Signal analysis	Digital Filter
11	DAQ	Ramp generator, Programmable power supply
12	Advanced DAQ	Oscilloscope, FFT

Table 1. Laboratory topics and accompanying virtual instruments

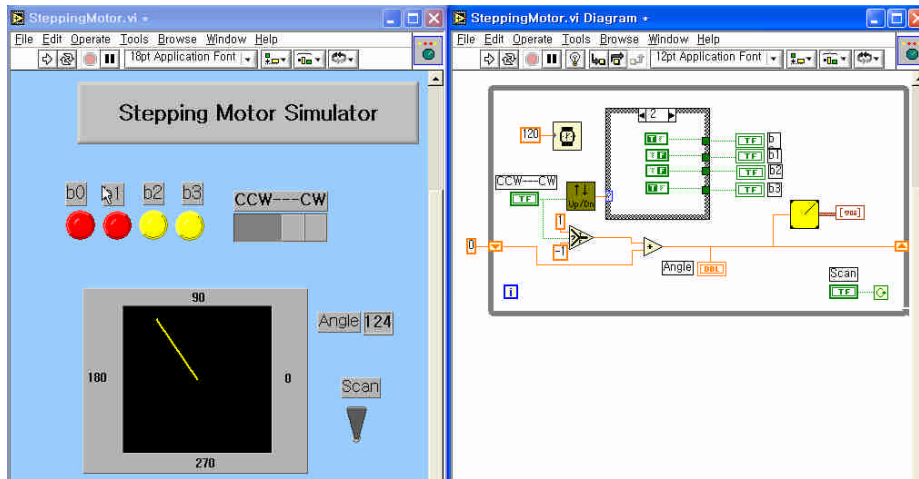

Figure 1 Front panel and block diagram of stepping motor simulator vi

System Components of the Laboratory

A single laboratory section of Korea University of Technology and Education consists of 20 students guided by a single faculty member. Each group of students has their own data acquisition workstation, and students often bring in additional laptop computer as secondary terminals for concurrent data analysis. The data-acquisition workstation operated by each group of students consists of the following components.

- Pentium 4 Desktop computer
- National Instrument LabVIEW software
- National Instrument Signal Accessory
- National Instrument AT-MIO-16 Multifunction I/O Board

- National Instrument B-50 Connection Block
- National Instrument DAQ Card-AI-16XE-50
- National Instrument Bread Board SC-2075
- Festo Sensor Practice System

Laboratory activities for the Mechatronics course include an introduction to sensors and transducers, calibration, uncertainty analysis, frequency response, signal processing and analysis, and independent projects. Before shifting to a virtual instrument based experiments for this course, laboratory activities tends to focus on programming examples in order to understand LabVIEW fundamentals. In this step, each laboratory activity is based on a LabVIEW virtual instrument written by the instructor, where the student can easily activate switches to energize the instrument or start the process.

Virtual Instrument Based Experiments

Prior to using virtual instruments in the course, all data have been manually collected, tabulated, and then processed. With virtual instruments, the students can walk into the laboratory, be introduced to the apparatus and the virtual instrument, and immediately begin collecting data. This process allows the experimental topics such as calibration or uncertainty analysis, to be the central theme of their experience in laboratory. For most experiments in the course, students do not create their own virtual instruments, but rather use a common interface designed by the instructors. This approach is important in order to keep the laboratory focused on the course topics, rather than a specific data acquisition programming language.

Students are exposed to LabVIEW graphical programming during the course, but this process is gradually built-in. A progressive exposure to create virtual instruments offer the best students the ability to create their own virtual instruments, and develop capstone design projects. The experiences gained in teaching and research at the Korea university of Technology and Education (KUT), University of Hartford and Moscow State Technological University ‘STANKIN’ are used in the development of case studies.

CASE STUDIES

Case Studies at KUT

Weight Measurement System with Virtual Instrument

Strain gauges are used to measure the displacement-strain relationship of the aluminum beam. In this system, double strain gauges are mounted on the two side of 15cm long aluminum beam. As the known weight is used at the end of the beam, the beam deflects according to the magnitude of the weight and the virtual instrument monitors the strain signal from the strain gauge. The external bridge circuitry is used for the strain gauge measurements. The external voltage source from the power supply is used as the excitation voltage for the strain gauge and the quarter bridge circuitry helps students understand the components of the Wheaston bridge, that are essential for many low voltage transducers. Figure 2 illustrates the Front Panel and Figure 3 illustrates the block diagram of the weight measurement system. At first, students calibrate the system, using five different known weights. The virtual instrument gathers the input signal and plots the weight versus voltage in the graph at the same time. After calibration, the students monitor the unknown mass using the virtual instrumentation. The learning objectives of these experiments are calibration and skill for curve fitting the experimental data.

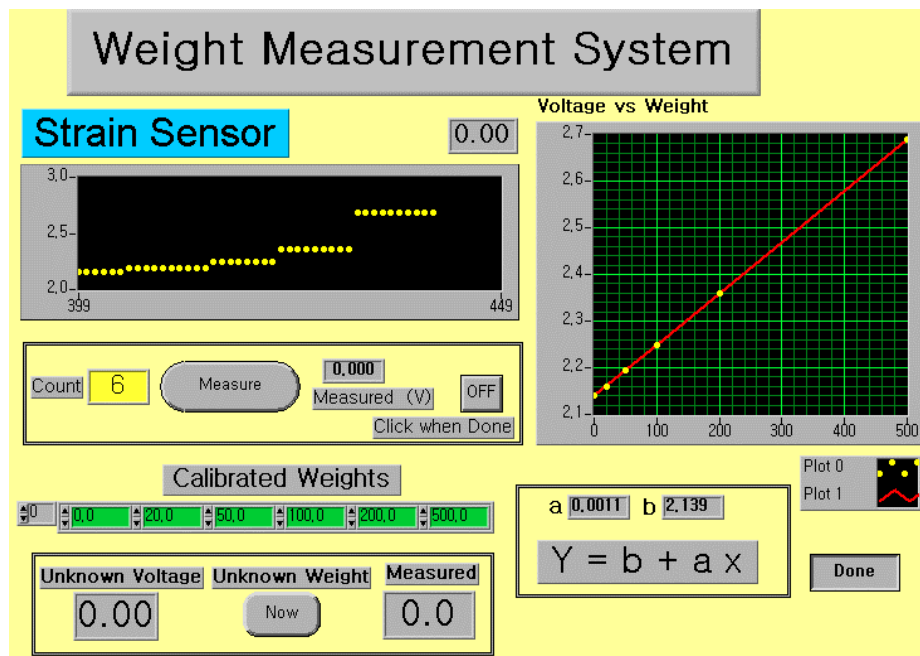

Figure 2 Front panel of the weight measurement system

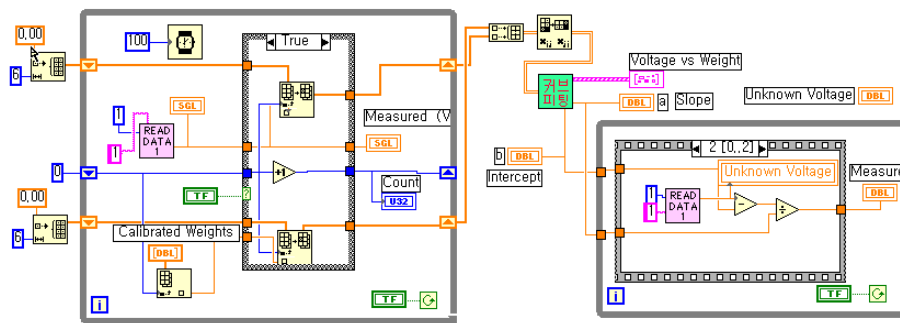

Figure 3 Block diagram of the weight measurement system

Robot Arm Control with Virtual Instrument

By combining LabVIEW with Fisher Technique blocks, the students learn to design virtual instrumentation programs to interact sensors and actuators in an innovative hands-on approach to mechatronics practice. Fisher Technique consists of sensors, motors, building blocks as well as a computer I/O interface. It provides highly capable, infinitely versatile and expandable system for control purpose. This system is inexpensive and it is fun, easy-to-use and inspires creativity in students. Using Fisher Technique system with LabVIEW graphical programming language, students can create their own virtual instruments to acquire and analyze data with sensors, perform advanced signal processing techniques or program Robot arm for interactive control.

Case Studies at the University of Hartford

Mechatronics Demonstrator

Mechatronics demonstrator is a mass-spring-damper system in order to educate a model based control system design and implementation using visual programming (VisSim) The kit consists of four major components, (1) mechanical mass-spring –damper assembly, (2) displacement sensor, (3) voice coil actuator, and (4) voice coil power amplifier. A system photograph is shown in Figure 4. The primary mass element in the system is a magnet. The spring effect is provided by the four supporting wires and the damping effect by the “flexing” of the four “L” brackets securing the device to the base. The operation of the system is based on forces produced by the magnetic voice-coil actuator, which in-turn, produce vertical motion of the suspended mass. Vertical displacement of the mass element is then sensed using a position-sensing detector. Both the sensor and actuator are interfaced to a computer based visual programming application using a data acquisition board.



Figure 4 Mechatronics Technology Demonstrator

Automatic Surface Roughness Measurement

Surface quality is a fingerprint of the production process. Monitoring surface roughness enhances the understanding of, and therefore enables a change in the production process. An essential part of the quality control in the manufacturing of precision parts is the measurement of the quality of the surface finish of the part produced, and more particularly, the roughness of the surface. Conventional measurement techniques often require surface contact with the object being measured, which could potentially damage the surface. The evaluation of roughness through surface contact involves the use of a stylus device, which is moved over the sample in order to detect and record variations in surface irregularities. A primary limitation of this technique is that stylus always has to traverse perpendicular to the lay on the surface. Compared to the contact stylus method of inspection, the optical technique developed at the University of Hartford is preferred because it can provide the same information in a quick, non-contact and flexible manner. The computerized surface roughness analyzer is an innovative laser based, computerized solution to roughness measurement problems. This system utilizes diffracted light patterns. The methodology developed is an exciting breakthrough in non-contact surface roughness measurement, thus providing efficient, precise, reliable data on the quality of machined surface in a non-destructive manner. There are two developed systems, one is for the measurement of the flat surface and the other is for the measurement of the tube inside. Figure 5 is the front panel of the virtual instrument for the measurement of the surface roughness of the tube inside.

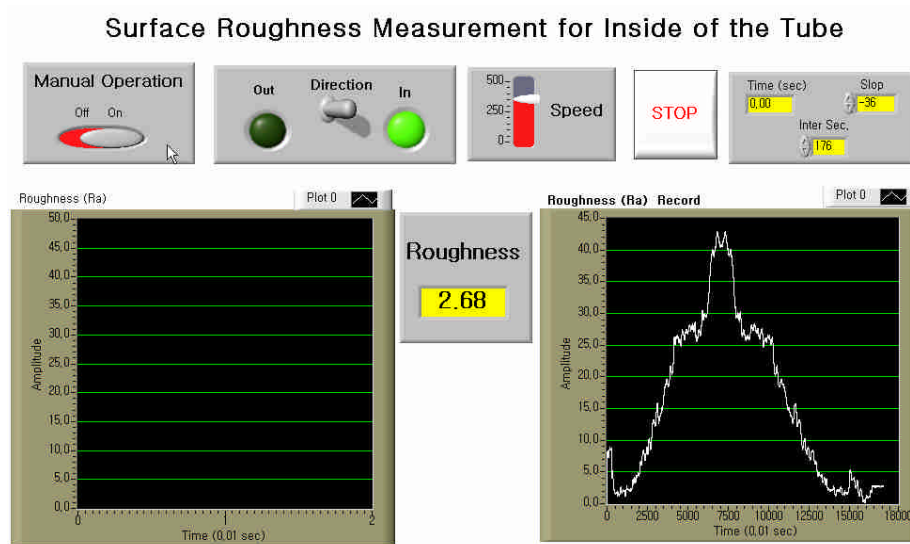

Figure 5 Font panel of surface roughness measurement system for inside of the tube

Case Study at the Moscow State Technological University “STANKIN”

Mobile Robot Control with Virtual Instrument via Internet

The experiment of the mobile robot control via Internet was carried out at the MSTU-Stankin research laboratories. The mobile robot "IRIS - 1" is intended for inspection and repairing of pipelines. It is equipped with two drives providing transportation of the robot in a pipe, along with a sensor system acquiring the information on the robot status and the environment conditions. Sensor system has incorporated the ultrasonic, microwave sensor, video camera, encoders linked with wheels and set of three, two-dimensional accelerometers. Video camera is also equipped with illuminating system. The robot control software is installed on the controlling computer.

For realization of remote control, the web server is developed, using the language of graphic programming – LabVIEW. The server searches for the remote operator, starts the control program for motors and data acquisition. With the use of the CGI interface, the commands of the operators submitted through the web-interface of a standard Internet - browser will be transformed to calls to the robot control program. This system can send a command on start/stop, change speed and direction of the robot movement. The sensor signal values are displayed as the diagrams and digital indicators on dynamically updated web page on the monitor of the operator. The transfer of the video image from the camera is also realized.

The processing of navigation variables, of the current robot status parameters is carried out on the

controlling computer. The supervisory program works in a real time mode, irrespective of the Internet time delays. Thus, in the event, that the operator shows some delay in reacting to the critical mode of operations because of the remote low speed data transfer, emergency stop will take place automatically, on a control program signal. Figure 6 is shown the schematic diagram of the mobile robot via Internet.

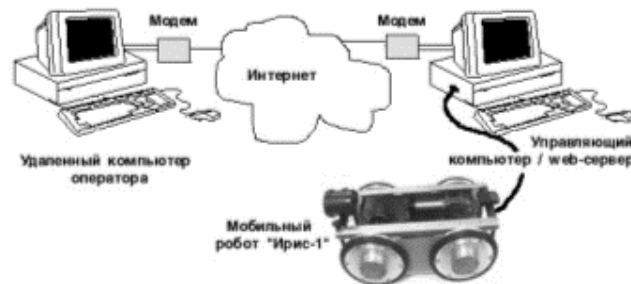

Figure 6 Mobile robot controls via Internet

International collaboration in Remote Real Laboratory via the Internet

Remote real laboratory offers faculty and students an exciting new way to teach and learn important concepts. Remote laboratory eliminates the typical barriers found in traditional laboratory setting because the web is available 24 hours a day 7 days a week from anywhere in the world. Students can access a remote laboratory from outside the classroom. With remote laboratories, professors can easily enhance the experience by integrating research demonstration into a classroom lecture, and can make the demonstration available to students at other irregular time. For the realization of the remote real laboratory, international joint research is in progress. The remote real laboratory will be used on a regular basis for mechatronics education of three universities, after it has been constructed.

Conclusions

The use of virtual instrument in the Mechatronics course is an effective way of supporting the interdisciplinary hand-on learning. Using the virtual instrumentation in laboratory provides dramatic improvement in Mechatronics education. LabVIEW's ease of use for building a virtual instrument, its flexibility and power are significant advantage in developing hands-on learning experience. The laboratory experiments are designed to interactively to teach some of the fundamental theory associated with each field. This not only reinforces basic knowledge, but also trains students in the application of these ideas in laboratory research.

For distance learning purposes, the virtual instruments and equipment for the remote real laboratory have been developed by the three-university. Experiments through remote real laboratory allow students to carry out experimental studies either on campus or remotely.

References

1. Devdas Shetty and Richard Kolk, "Mechatronics System Design", PWS Publishing Company, 1997
2. Ertugural Nesimi, "Towards Virtual Laboratories : a survey of LabVIEW-based Teaching/Learning Tools and Future Trends", Int. J. Eng Ed. Vol. 16, No. 3, 2000, pp171-180
3. Barry Paton, "Sensors, Transducers & LabVIEW", Prentice Hall PTR, 1999
4. Bishop Robert, "Learning with LabVIEW 6i", Prentice Hall, 2001
5. Seong Joo Choi and Barry Paton , "LabVIEW application : DAQ & Machine Vision", Course Material of Human Resources Development Institute, Korea University of Technology and Education, 2002. 1
6. Wilczynsk Vincent, "A Virtual Instrumentation based Engineering Experimentati on Course", Virtual Instrumentation in Education, Conference Proceedings, 1997, pp19-26
7. Ivan Ermolov, Anton Levenkov, Jury Poduraev and Seong Joo Choi, "Internet Control of Mobile Robot for Pipe Inspection/Repair", International Workshop on Computer Science and Information Technology, Conference Proceedings, 2002
8. Buckman Bruce, "A Course in Computer-based Instrumentation : learning LabVIEW with Case Studies", Int. J. Eng Ed. Vol. 16, No. 3, 2000, pp228-233
9. VanArsdale William, "Using LabVIEW in an Undergraduate Course on Experimental Methods", Virtual Instrumentation in Education, Conference Proceedings, 1997, pp47-51
10. Barry Paton, "LabVIEW puts a new spin on teaching Digital Electronics", Virtual Instrumentation in Education, Conference Proceedings, 1997, pp163-172
11. Seong Joo Choi, "DAQ Hands-on Seminar for Biomechanical Engineering" Seminar Hands-out material, University of Hartford, September 2002