

Last Revised: 2014-11-06 07:14:18.0

NI SCXI Voltage and Thermocouple Input Modules



- Hardware scanning of cold-junction sensors
- 2 Hz lowpass filtering per channel
- Overvoltage protection to ± 42 V
- 333 kS/s maximum sampling rate
- NI measurement services software that simplifies configuration and measurements
- Programmatic input range of ± 100 mV or ± 10 V per channel
- Thermocouple, millivolt, volt, and current input

Overview

National Instruments offers a variety of 32-channel analog input modules for SCXI, including the SCXI-1100, SCXI-1102 Series, and SCXI-1104 Series. The programmable gain and filter settings are ideal for conditioning a variety of millivolt, volt, and current inputs. The SCXI-1104 multiplexes the 32 channels into a single channel of the DAQ device, and you can add modules to increase channel count.

The NI SCXI-1102 and SCXI-1112 are designed for high-accuracy thermocouple measurements. The SCXI-1102 also can acquire millivolt, volt, 0 to 20 mA, and 4 to 20 mA current input signals, as well as signals from RTDs when the NI SCXI-1581 provides excitation. Each input channel includes an instrumentation amplifier and a 2 Hz lowpass filter. The SCXI-1112 incorporates open thermocouple detection circuitry on each input channel. LEDs on the front of the module indicate the presence of an open thermocouple.

[Back to Top](#)

Requirements and Compatibility

OS Information

- Windows 2000/XP
- Windows NT
- Windows Vista

Driver Information

- NI-DAQmx

Software Compatibility

- LabVIEW Professional Development System
- LabWindows/CVI Full Development System
- VI Logger

[Back to Top](#)

Comparison Tables

Module	Channels	Thermocouple	RTD	Range	0 to 20 mA
SCXI-1102	32	yes	yes	± 100 mV, ± 10 V	yes
SCXI-1112	8	yes	no	± 10 V	no
SCXI-1104	32	no	no	± 60 VDC	no
SCXI-1100	32	no	no	± 10 V	yes

[Back to Top](#)

Application and Technology

Terminal Block	Part Number	Type	CJ Sensor	Compatible Modules	Cabling
SCXI-1300	777687-00	Screw terminals Front-mounting	✓	SCXI-1102B, SCXI-1102C, SCXI-1104, SCXI-1104C, SCXI-1100	–
SCXI-1303	777687-03	Screw terminals Front-mounting	✓	SCXI-1102B, SCXI-1102C, SCXI-1100	–
SCXI-1308	777687-08	Screw terminals Front-mounting	–	SCXI-1102B, SCXI-1102C, SCXI-1100	–
TC-2095	777509-01	Thermocouple, plugs Rack-mounted	✓	SCXI-1100, SCXI-1102B, SCXI-1102C	SH96-96 or R96-96
TBX-1303	777207-03	Screw terminals	✓	SCXI-1102B, SCXI-1102C, SCXI-1104, SCXI-1104C, SCXI-1100	SH96-96 or R96-96
TBX-96	777264-01	Screw terminals DIN-rail mount	–	SCXI-1100, SCXI-1102B, SCXI-1102C, SCXI-1104,	SH96-96 or R96-96
SCXI-1310	777687-10	Solder pins Front-mounting	–	SCXI-1102B, SCXI-1102C, SCXI-1104, SCXI-1100	–

Terminal Block Options for NI SCXI-1102

[Back to Top](#)

Software Recommendations

LabVIEW Professional Development System for Windows



- Advanced software tools for large project development
- Automatic code generation using DAQ Assistant and Instrument I/O Assistant
- Tight integration with a wide range of hardware
- Advanced measurement analysis and digital signal processing
- Open connectivity with DLLs, ActiveX, and .NET objects
- Capability to build DLLs, executables, and MSI installers

NI LabWindows™/CVI for Windows

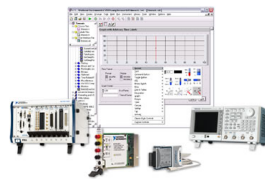

- Real-time advanced 2D graphs and charts
- Complete hardware compatibility with IVI, VISA, DAQ, GPIB, and serial
- Analysis tools for array manipulation, signal processing statistics, and curve fitting
- Simplified cross-platform communication with network variables
- Measurement Studio .NET tools (included in LabWindows/CVI Full only)
- The mark LabWindows is used under a license from Microsoft Corporation.

[Back to Top](#)

Support and Services

System Assurance Programs

NI system assurance programs are designed to make it even easier for you to own an NI system. These programs include configuration and deployment services for your NI PXI, CompactRIO, or Compact FieldPoint system. The NI Basic System Assurance Program provides a simple integration test and ensures that your system is delivered completely assembled in one box. When you configure your system with the NI Standard System Assurance Program, you can select from available NI system driver sets and application development environments to create customized, reorderable software configurations. Your system arrives fully assembled and tested in one box with your software preinstalled. When you order your system with the standard program, you also receive system-specific documentation including a bill of materials, an integration test report, a recommended maintenance plan, and frequently asked question documents. Finally, the standard program reduces the total cost of owning an NI system by providing three years of warranty coverage and calibration service. Use the online product advisors at ni.com/advisor to find a system assurance program to meet your needs.

Calibration

NI measurement hardware is calibrated to ensure measurement accuracy and verify that the device meets its published specifications. To ensure the ongoing accuracy of your measurement hardware, NI offers basic or detailed recalibration service that provides ongoing ISO 9001 audit compliance and confidence in your measurements. To learn more about NI calibration services or to locate a qualified service center near you, contact your local sales office or visit ni.com/calibration.

Technical Support

Get answers to your technical questions using the following National Instruments resources.

- **Support** - Visit ni.com/support to access the NI KnowledgeBase, example programs, and tutorials or to contact our applications engineers who are located in NI sales offices around the world and speak the local language.
- **Discussion Forums** - Visit forums.ni.com for a diverse set of discussion boards on topics you care about.
- **Online Community** - Visit community.ni.com to find, contribute, or collaborate on customer-contributed technical content with users like you.

Repair

While you may never need your hardware repaired, NI understands that unexpected events may lead to necessary repairs. NI offers repair services performed by highly trained technicians who quickly return your device with the guarantee that it will perform to factory specifications. For more information, visit ni.com/repair.

Training and Certifications

The NI training and certification program delivers the fastest, most certain route to increased proficiency and productivity using NI software and hardware. Training builds the skills to more efficiently develop robust, maintainable applications, while certification validates your knowledge and ability.

- **Classroom training in cities worldwide** - the most comprehensive hands-on training taught by engineers.
- **On-site training at your facility** - an excellent option to train multiple employees at the same time.
- **Online instructor-led training** - lower-cost, remote training if classroom or on-site courses are not possible.
- **Course kits** - lowest-cost, self-paced training that you can use as reference guides.
- **Training memberships** and training credits - to buy now and schedule training later.

Visit ni.com/training for more information.

Extended Warranty

NI offers options for extending the standard product warranty to meet the life-cycle requirements of your project. In addition, because NI understands that your requirements may change, the extended warranty is flexible in length and easily renewed. For more information, visit ni.com/warranty.

OEM

NI offers design-in consulting and product integration assistance if you need NI products for OEM applications. For information about special pricing and services for OEM customers, visit ni.com/oem.

Alliance

Our Professional Services Team is comprised of NI applications engineers, NI Consulting Services, and a worldwide National Instruments Alliance Partner program of more than 700 independent consultants and integrators. Services range from start-up assistance to turnkey system integration. Visit ni.com/alliance.

[Back to Top](#)

Detailed Specifications

This topic lists the specifications for the SCXI-1102/B/C modules. These specifications are typical at 25 °C unless otherwise noted.

Analog Input	
Input Characteristics	
Number of channels	32 differential
Input signal ranges	±100 mV (gain = 100) or ±10 V (gain = 1)
Input damage level	
Powered on	±42 VDC
Powered off	±27 VDC
Inputs protected	CH<0..31>, CJ SENSOR
Transfer Characteristics	
Nonlinearity	0.005% FSR
Offset error	
Gain = 1	
After calibration	300 µV max
Before calibration	600 µV
Gain = 100	
After calibration	15 µV max
Before calibration	100 µV
Gain error (relative to calibration reference)	
Gain = 1	
After calibration	0.015% of reading max
Before calibration	0.04% of reading
Gain = 100	
After calibration	0.020% of reading max
Before calibration	0.1% of reading

Amplifier Characteristics

Input impedance	
Normal powered on	>1 G Ω
Powered off	10 k Ω
Overload	10 k Ω
Input bias current	± 0.5 nA
Input offset current	± 1.0 nA

CMRR			
Characteristics	1102	1102B	1102C
50 to 60 Hz, either gain	110 dB	90 dB	90 dB
DC, gain 1	75 dB min	75 dB min	75 dB min
DC, gain 100	100 dB min	100 dB min	100 dB min

Output range	± 10 V
Output impedance	91 Ω

Dynamic Characteristics

Bandwidth	2 Hz (1102), 200 Hz (1102B), 10 kHz (1102C)
Minimum scan interval (per channel, any gain)	
$\pm 0.012\%$ accuracy	3 μ s
$\pm 0.0061\%$ accuracy	10 μ s

System noise (RTI)			
Characteristics	1102	1102B	1102C
Gain = 1	50 μ V _{rms}	50 μ V _{rms}	70 μ V _{rms}
Gain = 100	5 μ V _{rms}	5 μ V _{rms}	10 μ V _{rms}

Filters

Cutoff frequency (-3 dB)	2 Hz (1102), 200 Hz (1102B), 10 kHz (1102C)
NMR (60 Hz)	40 dB (1102)

Step response (either gain)			
Characteristics	1102	1102B	1102C
To 0.1%	1 s	10 ms	200 μ s
To 0.01%	10 s	100 ms	1 μ s

Stability

Recommended warm-up time	20 min
Offset temperature coefficient	
Gain = 1	20 μ V/ $^{\circ}$ C
Gain = 100	1 μ V/ $^{\circ}$ C
Gain temperature coefficient	10 ppm/ $^{\circ}$ C

Power Requirements

5 V supply	15 mA max
± 15 V supply (regulated from ± 24 V supply)	150 mA max

Physical

SCXI-1102/B/C Dimensions

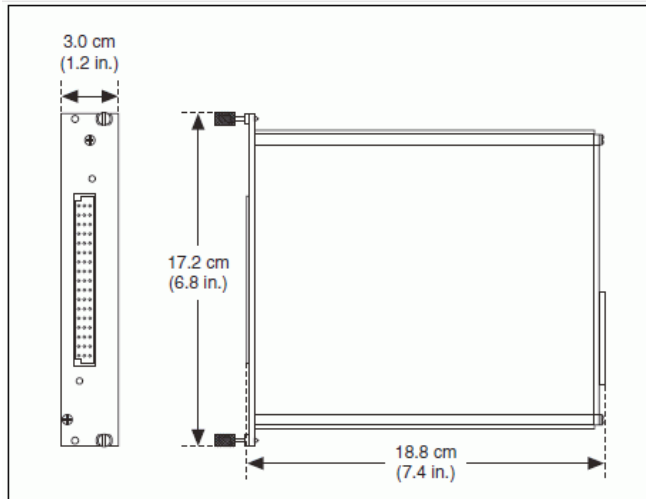

Weight

611 gm (24.6 oz)

Maximum Working Voltage

Maximum working voltage refers to the signal voltage plus the common-mode voltage.

Signal + common mode

Each input should remain within ± 10 V of CH GND

Environmental

Operating temperature

0 to 50 °C

Storage temperature

-20 to 70 °C

Humidity

10 to 90% RH, noncondensing

Maximum altitude

2,000 m

Pollution Degree (indoor use only)

2

Safety Standards

This product is designed to meet the requirements of the following standards of safety for electrical equipment for measurement, control, and laboratory use:

- IEC 61010-1, EN 61010-1
- UL 61010-1, CSA 61010-1



Note For UL and other safety certifications, refer to the product label or the *Online Product Certification* section.

Electromagnetic Compatibility

This product is designed to meet the requirements of the following standards of EMC for electrical equipment for measurement, control, and laboratory use:

- EN 61326 EMC requirements; Minimum Immunity
- EN 55011 Emissions; Group 1, Class A
- CE, C-Tick, ICES, and FCC Part 15 Emissions; Class A



Note For EMC compliance, operate this device with shielded cables.

CE Compliance

This product meets the essential requirements of applicable European Directives, as amended for CE marking, as follows:

Low-Voltage Directive (safety)

73/23/EEC

Electromagnetic Compatibility Directive (EMC)

89/336/EEC



Note Refer to the Declaration of Conformity (DoC) for this product for any additional regulatory compliance information. To obtain the DoC for this product, visit ni.com/certification, search by model number or product line, and click the appropriate link in the Certification column.

Waste Electrical and Electronic Equipment (WEEE)



EU Customers At the end of the product life cycle, all products *must* be sent to a WEEE recycling center. For more information about WEEE recycling centers, National Instruments WEEE initiatives, and compliance with WEEE Directive 2002/96/EC on Waste Electrical and Electronic Equipment, visit ni.com/environment/weee.htm.

电子信息产品污染控制管理办法（中国 RoHS）



中国客户 National Instruments 符合中国电子信息产品中限制使用某些有害物质指令 (RoHS)。
关于 National Instruments 中国 RoHS 合规性信息, 请登录 ni.com/environment/rohs_china。
(For Information about China RoHS compliance, go to ni.com/environment/rohs_china.)

[Back to Top](#)

Pinouts/Front Panel Connections

Rear Signal Pin Assignments

Rear Connector Diagram	Signal Name	Pin Number	Pin Number	Signal Name
	AI GND	1	2	AI GND
	CH 0 +	3	4	CH 0 -
	NC	5	6	NC
	NC	7	8	NC
	NC	9	10	NC
	NC	11	12	NC
	NC	13	14	NC
	NC	15	16	NC
	NC	17	18	NC
	OUT REF	19	20	NC
	NC	21	22	NC
	NC	23	24	D GND
	SER DAT IN	25	26	SER DAT OUT
	DAQ D*/A	27	28	NC
	SLOT 0 SEL*	29	30	NC
	D GND	31	32	NC
	NC	33	34	NC
	NC	35	36	AI HOLD COMP, AI HOLD
	SER CLK	37	38	NC
	NC	39	40	NC
	NC	41	42	NC
	RSVD	43	44	NC
	NC	45	46	RSVD
	NC	47	48	NC
	NC	49	50	NC

NC—No Connection

SCXI-1102/B/C Front Signal Pin Assignments

Front Connector Diagram	Pin Number	Column A	Column B	Column C
	32	CH GND	AI 0 -	AI 0 +
	31	NC	AI 1 -	AI 1 +
	30	NC	AI 2 -	AI 2 +
	29	NC	AI 3 -	AI 3 +
	28	NC	AI 4 -	AI 4 +
	27	NC	AI 5 -	AI 5 +
	26	NC	AI 6 -	AI 6 +
	25	NC	AI 7 -	AI 7 +
	24	CH GND	AI 8 -	AI 8 +
	23	NC	AI 9 -	AI 9 +
	22	NC	AI 10 -	AI 10 +
	21	NC	AI 11 -	AI 11 +
	20	NC	AI 12 -	AI 12 +
	19	NC	AI 13 -	AI 13 +
	18	NC	AI 14 -	AI 14 +
	17	NC	AI 15 -	AI 15 +
	16	CH GND	AI 16 -	AI 16 +
	15	NC	AI 17 -	AI 17 +
	14	NC	AI 18 -	AI 18 +
	13	NC	AI 19 -	AI 19 +
	12	NC	AI 20 -	AI 20 +
	11	NC	AI 21 -	AI 21 +
	10	NC	AI 22 -	AI 22 +
	9	NC	AI 23 -	AI 23 +
	8	NC	AI 24 -	AI 24 +
	7	NC	AI 25 -	AI 25 +
	6	NC	AI 26 -	AI 26 +
	5	CH GND	AI 27 -	AI 27 +
	4	CJ SENSOR	AI 28 -	AI 28 +
	3	CJ SENSOR	AI 29 -	AI 29 +
	2	CH GND	AI 30 -	AI 30 +
	1	+5 V	AI 31 -	AI 31 +

NC—No Connection

[Back to Top](#)

©2012 National Instruments. All rights reserved. CompactRIO, CVI, FieldPoint, LabVIEW, Measurement Studio, National Instruments, NI, ni.com, NI-DAQ, and SCXI are trademarks of National Instruments. The mark LabWindows is used under a license from Microsoft Corporation. Windows is a registered trademark of Microsoft Corporation in the United States and other countries. Other product and company names listed are trademarks or trade names of their respective companies. A National Instruments Alliance Partner is a business entity independent from National Instruments and has no agency, partnership, or joint-venture relationship with National Instruments.

[My Profile](#) | [RSS](#) | [Privacy](#) | [Legal](#) | [Contact NI](#) © 2014 National Instruments Corporation. All rights reserved.